

# HGT

Data sheet - rev. 1.3



# LINEAR COMPONENTS

## myRollon

myRollon is Rollon's **digital working platform** designed to simplify the selection and configuration of linear and rotary motion solutions. It enables users to identify the most suitable motion system based on their specific application requirements, enhancing design precision and efficiency.

By centralizing essential tools and resources in a unified environment, myRollon empowers users to access all necessary services and information — saving time and boosting productivity in search of high-performance motion solutions.

SCAN ME!



# Index

Ordering key.....	4
Features and advantages.....	5
Components and dimensions .....	6
Accessories .....	23
Use and maintenance .....	25
Static load.....	31

## ▶ ORDERING KEY

### ■ HGT

HGT		030		0000	0000						R		
	X	035	MG			EG	VG	DG	B	Z	L		
		060				EO	VO		BM				
		080				EB	VB						
		100											
		120											
		150											
		200											
		240											
												<b>Layout</b> - R = right version, L = left version	
												<b>Surface treatment</b> - Standard = zinc plating, Z = zinc-nickel	
												<b>Stroke direction</b> - B = double-sided, BM = double-sided with driving disc (see page 24)	
												<b>Damping</b> - DG = closed position	
												<b>Locking position</b> - VG = closed, VO = opened, VB = both (see page 24)	
												<b>Snap on position</b> - EG = closed, EO = opened, EB = both (see page 24)	
												<b>Stroke [mm]</b> - if deviating from standard stroke (catalogue data)	
												<b>Closed length [mm]</b>	
												<b>Device</b> - MG = magnetic device (available for size 60 and 80)	
												<b>Size</b> (see from page 6)	
												<b>Material</b> - Standard = steel, X = stainless steel	
<b>Series</b>													

Ordering example: **HGT080-0500-0600-VG**

Rail lengths and stroke lengths are always stated with four digits. Please pad with zeros to fill in lengths with fewer than four digits, e.g. 530mm length is a "0530". Not all fields must be filled out. If they are not used, they remain empty.

Not all accessories (EG/EO/EB, VG/VO/VB, DG, B, BM) can be combined with each other. Please contact our technical department if multiple options need to be combined.

## ► FEATURES AND ADVANTAGES

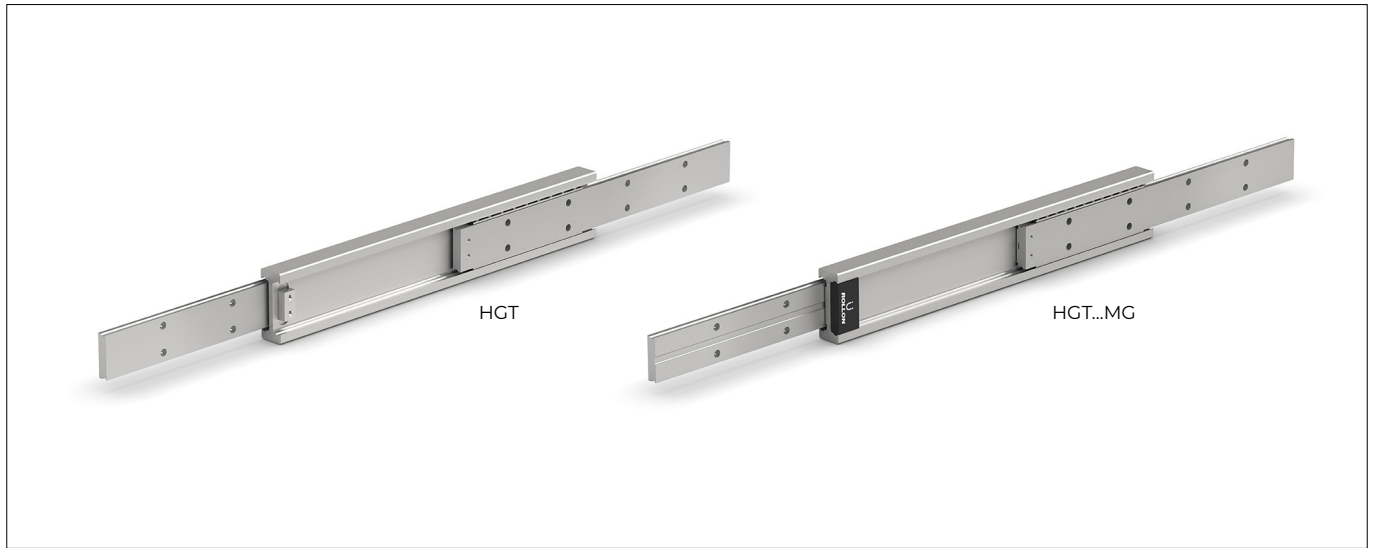

Fig.1

**HGT telescopic rails are fully extending, heavy-duty rails made of steel or stainless steel, designed for demanding applications.**

They consist of a double T-shaped intermediate element and two corresponding sliders. Both the rails and sliders are made of non-hardened steel and zinc plating with thick-film passivation. Available also in stainless steel, these telescopic rails are fully REACH and RoHS compliant.

The HGT-MG version, available for sizes 60 and 80, introduces a redesigned ball cage with a reduced pitch and end blocks containing internal magnets. These magnets synchronize the elements during extension, reducing the force required to open the rail and enabling the handling of higher loads. The damped end-stroke enhances quiet operation and improves overall durability.

Special features – such as locking mechanisms, double strokes, and catches – are available upon request.

HGT telescopic rails are particularly suited for use in construction and machine technology, as well as in motor and rail vehicle applications (maintenance and battery compartments).

### Performance characteristics

- Extension: full, 100%.
- Stroke direction: single or double.
- Available sizes: 30, 35, 60, 80, 100, 120, 150, 200, 240.
- Available rail lengths: from 250 mm up to 2000 mm.
- Max. extension speed: 0.4\* m/s.
- Max. acceleration: 0.6\* m/s<sup>2</sup>.
- Operating temperature range: -20 °C to +170 °C. For details see page 25.

\*Depending on the application (see page 25).

### Components and materials

- Rails and sliders: steel or stainless steel\*.
- Balls material: steel or stainless steel\*.
- Ball cage material: steel or stainless steel\*.
- Surface treatment: zinc plating, and REACH/RoHS compliant.

\*Depending on the HGT version.

HGT series can also be produced in aluminum or AISI 316 for broader-scale projects. For more information, please contact us.

## MAIN ADVANTAGES

### High load capacity

HGT rails are designed to withstand heavy loads while maintaining rigidity and minimal deflection.

### Compact design

Thanks to their optimized structure, HGT rails offer a compact and space-saving solution.

### Robustness

Robust design adapted for industrial applications with a moderate number of cycles and high loads.

### Uniquely quiet

In the HGT-MG version, the damped end-stroke enhances quiet and fluid operation.

### Corrosion resistance

Stainless steel options and the availability of different surface treatments support higher resistance in challenging environments.

## ▶ COMPONENTS AND DIMENSIONS

### ■ Guide sections

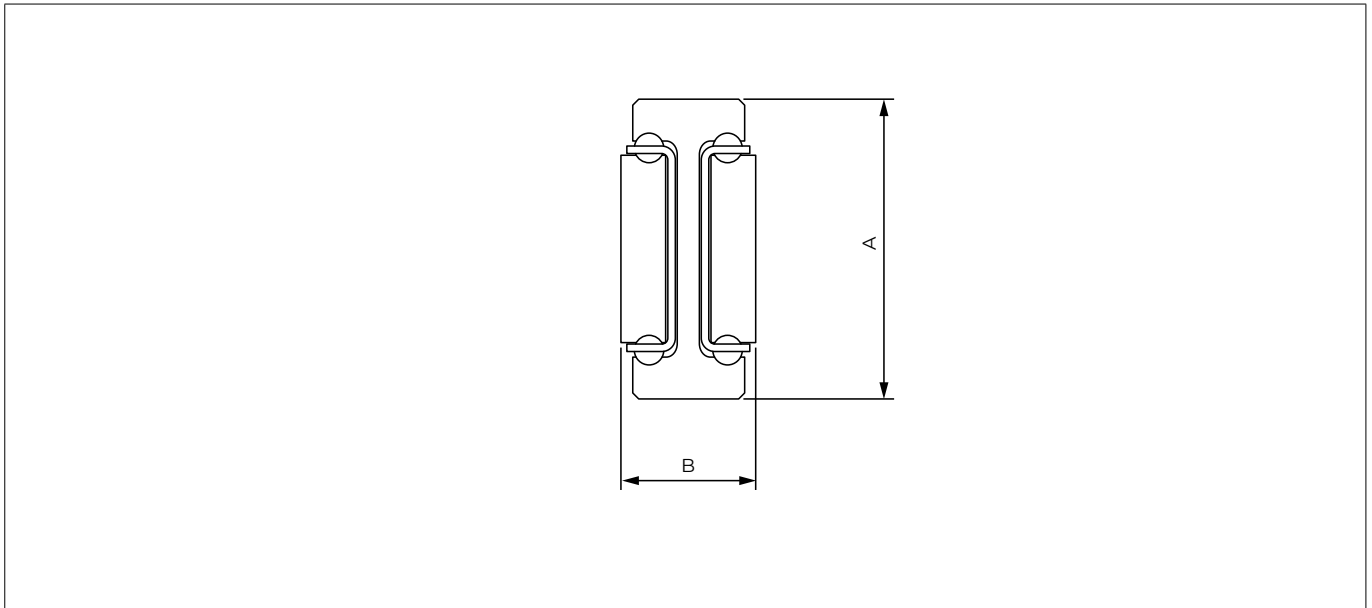
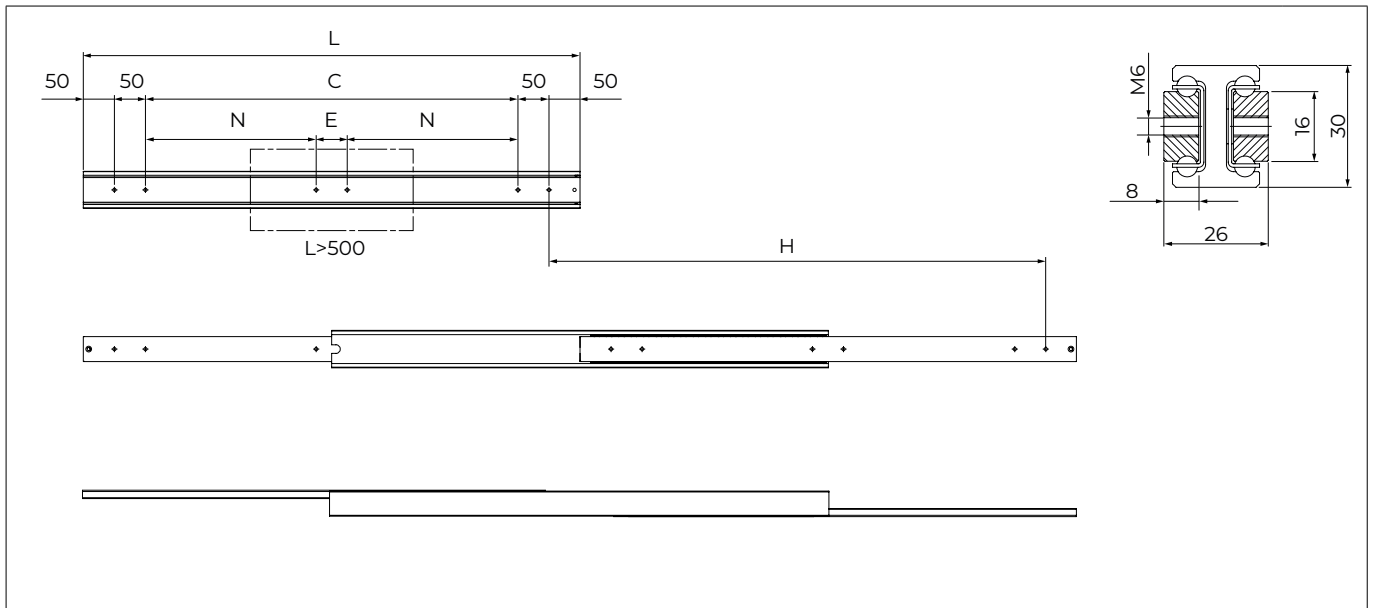

Fig.2

Type	Size	A [mm]	B [mm]
HGT	030	30	26
	035	35	30
	060 / 060MG	60	32
	080 / 080MG	80	36
	100	100	44
	120	120	44
	150	150	56
	200	200	72
	240	240	74

Tab.1

■ HGTX030 stainless steel



Rail, sliders, balls, and ball cages are made of stainless steel AISI 304.

Fig.3

Type	Size	Length L [mm]	Stroke H [mm]	$C_{Orad}$ [N]	C [mm]	N [mm]	E [mm]	Number of holes	Weight per single guide [kg]
HGTX	030	250	250	871	50	-	-	4	1.2
		300	300	948	100	-	-	4	1.4
		350	350	958	150	-	-	4	1.6
		400	400	931	200	-	-	4	1.8
		450	450	903	250	-	-	4	2.1
		500	500	723	300	-	-	4	2.3
		550	550	922	350	150	50	6	2.5
		600	600	920	400	175	50	6	2.8
		650	650	938	450	200	50	6	3.0
		700	700	735	500	225	50	6	3.2
		750	750	732	550	250	50	6	3.5
		800	800	742	600	275	50	6	3.7
		850	850	770	650	300	50	6	3.9
		900	900	597	700	325	50	6	4.1
		950	950	604	750	350	50	6	4.4
1000	1000	622	800	375	50	6	4.6		

\*Load capacity per pair.

Tab.2

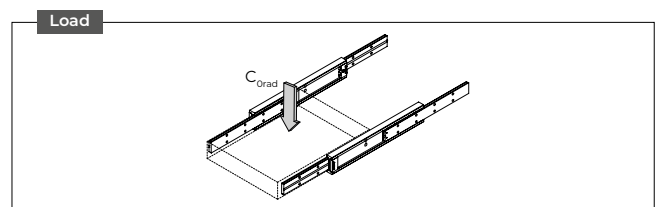

■ HGTX035 stainless steel

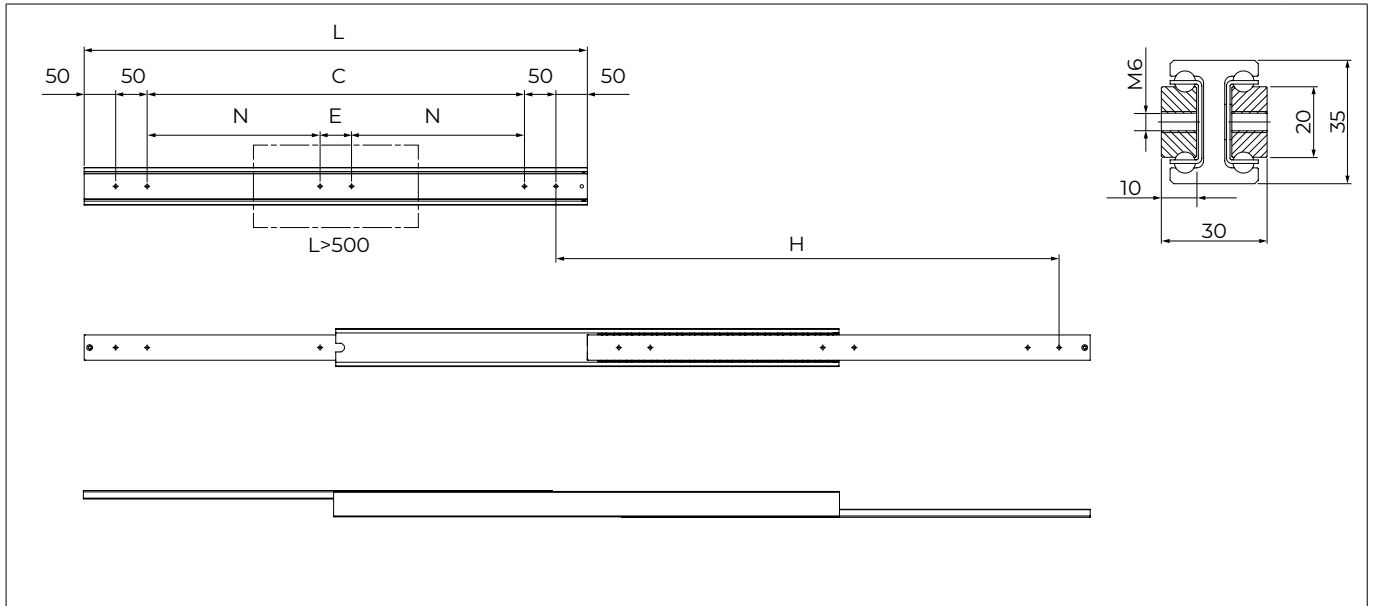

Rail, sliders, balls, and ball cages are made of stainless steel AISI 304.

Fig.4

Type	Size	Length L [mm]	Stroke H [mm]	$C_{Orad}$ [N]	C [mm]	N [mm]	E [mm]	Number of holes	Weight per single guide [kg]
HGTX	035	250	250	939	50	-	-	4	1.6
		300	300	1446	100	-	-	4	1.9
		350	350	1390	150	-	-	4	2.2
		400	400	1267	200	-	-	4	2.5
		450	450	1126	250	-	-	4	2.5
		500	500	1209	300	-	-	4	3.1
		550	550	1344	350	150	50	6	3.4
		600	600	1235	400	175	50	6	3.7
		650	650	1144	450	200	50	6	4.0
		700	700	1202	500	225	50	6	4.3
		750	750	1110	550	250	50	6	4.6
		800	800	1033	600	275	50	6	5.0
		850	850	968	650	300	50	6	5.3
		900	900	1006	700	325	50	6	5.6
		950	950	941	750	350	50	6	5.9
1000	1000	886	800	375	50	6	6.2		

\*Load capacity per pair

Tab.3

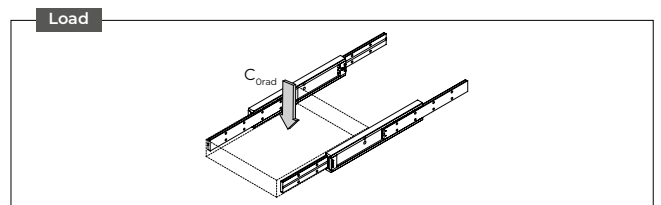

■ HGT060

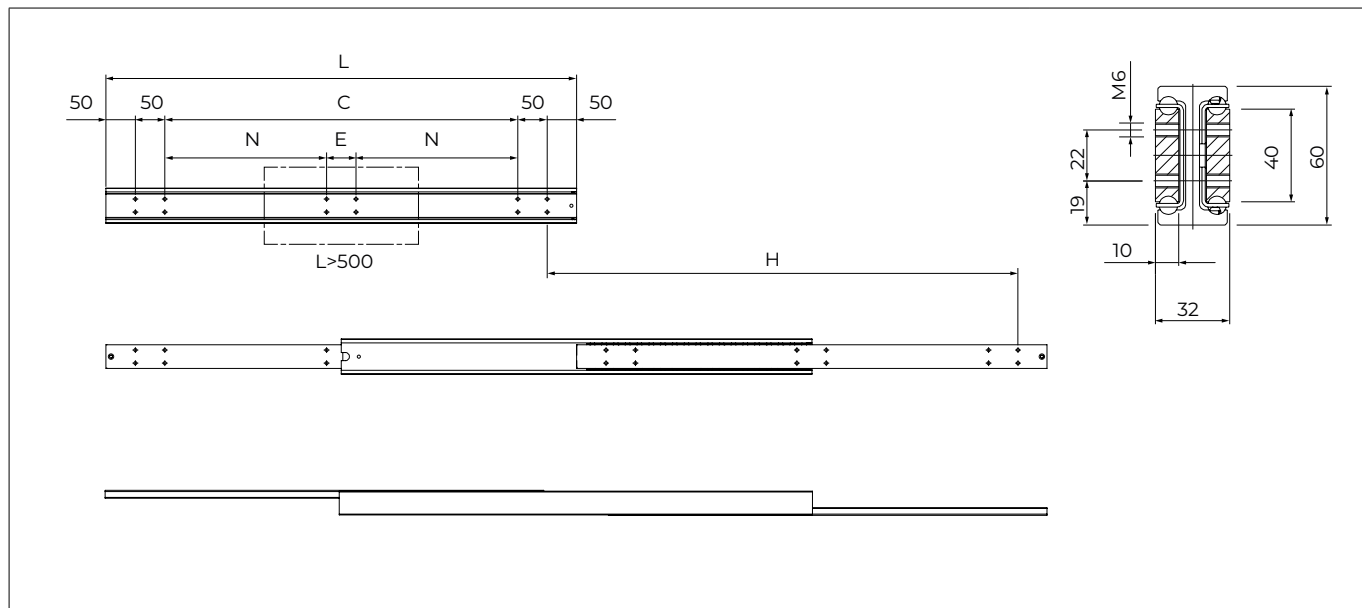
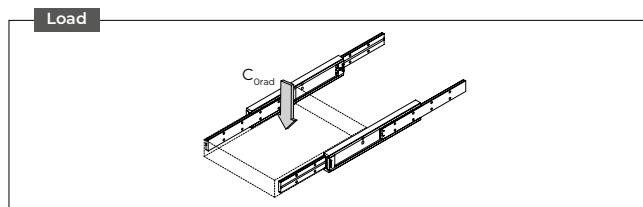

Fig.5

Type	Size	Length L [mm]	Stroke H [mm]	$C_{Grad}$ [N]	C [mm]	N [mm]	E [mm]	Number of holes	Weight per single guide [kg]
HGT	060	400	400	2697	200	-	-	8	4.6
		450	450	3543	250	-	-	8	5.2
		500	500	3395	300	-	-	8	5.8
		550	550	3506	350	150	50	12	6.3
		600	600	3450	400	175	50	12	6.9
		650	650	3817	450	200	50	12	7.5
		700	700	3682	500	225	50	12	8.1
		750	750	3554	550	250	50	12	8.7
		800	800	3433	600	275	50	12	9.2
		850	850	3528	650	300	50	12	9.8
		900	900	3378	700	325	50	12	10.4
		950	950	3243	750	350	50	12	11.0
		1000	1000	3124	800	375	50	12	11.6
		1100	1100	2969	900	425	50	12	12.7
		1200	1200	2758	1000	475	50	12	13.9
1300	1300	2574	1100	525	50	12	15.1		
1400	1400	2405	1200	575	50	12	16.2		
1500	1500	2228	1300	625	50	12	17.4		

\*Load capacity per pair

Tab.4



■ HGTX060 stainless steel

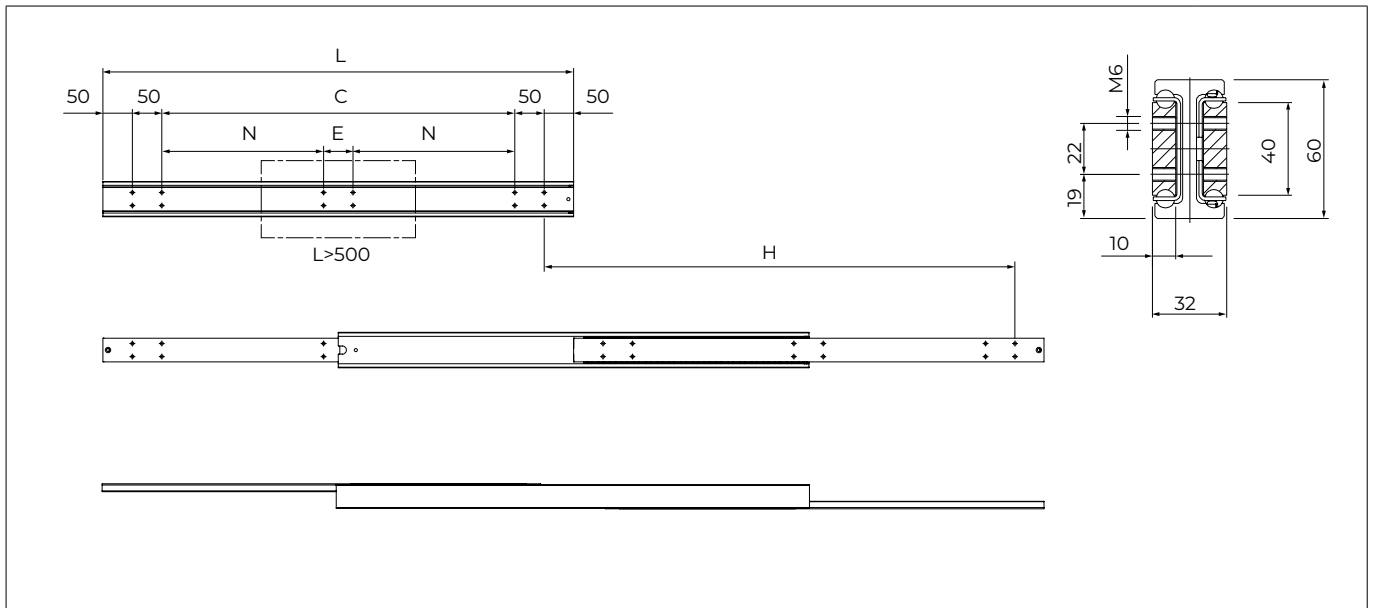

Rail, sliders, and ball cages are made of stainless steel AISI 304. The balls are made of stainless steel AISI 420C.

Fig.6

Type	Size	Length L [mm]	Stroke H [mm]	$C_{Orad}$ [N]	C [mm]	N [mm]	E [mm]	Number of holes	Weight per single guide [kg]
HGTX	060	400	400	2697	200	-	-	8	4.6
		450	450	3543	250	-	-	8	5.2
		500	500	3395	300	-	-	8	5.8
		550	550	3506	350	150	50	12	6.3
		600	600	3450	400	175	50	12	6.9
		650	650	3817	450	200	50	12	7.5
		700	700	3682	500	225	50	12	8.1
		750	750	3554	550	250	50	12	8.7
		800	800	3433	600	275	50	12	9.2
		850	850	3528	650	300	50	12	9.8
		900	900	3378	700	325	50	12	10.4
		950	950	3243	750	350	50	12	11.0
		1000	1000	3124	800	375	50	12	11.6
		1100	1100	2969	900	425	50	12	12.7
		1200	1200	2758	1000	475	50	12	13.9
1300	1300	2574	1100	525	50	12	15.1		
1400	1400	2405	1200	575	50	12	16.2		
1500	1500	2228	1300	625	50	12	17.4		

\*Load capacity per pair.

Tab.5

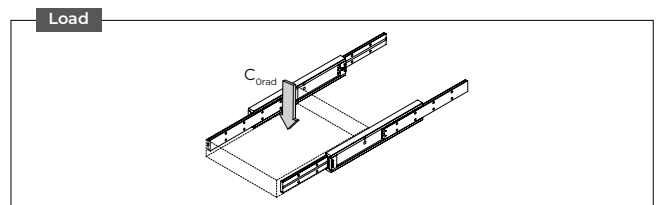

■ HGT060MG

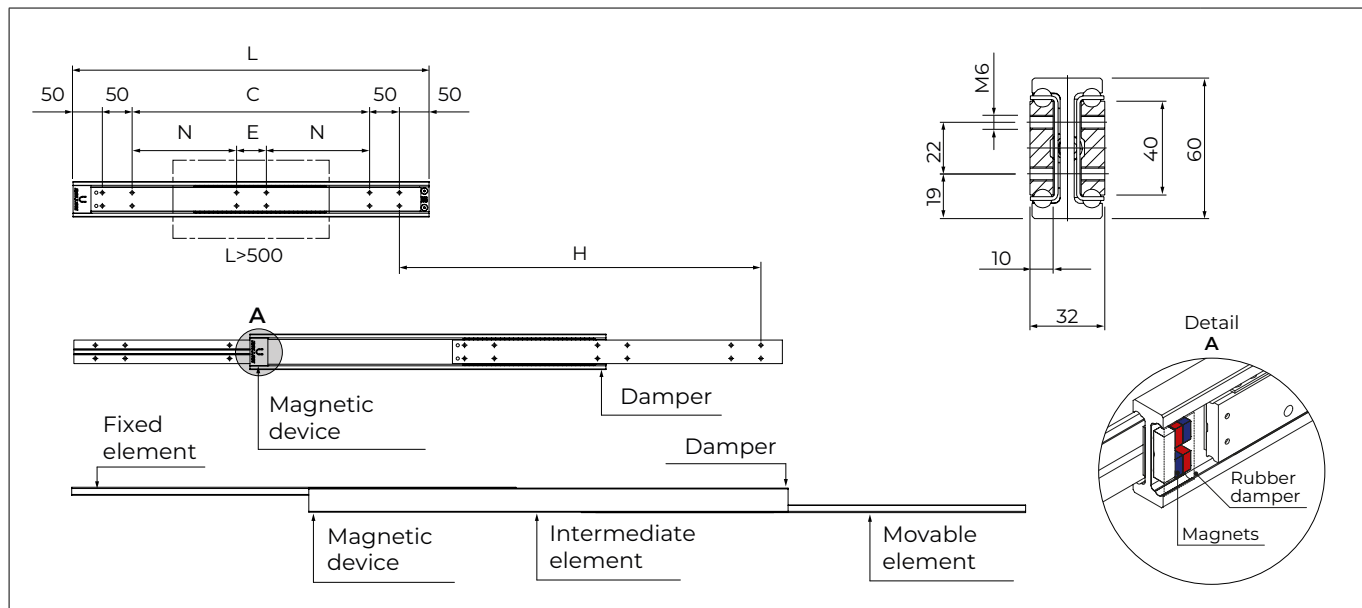

For installation in the application, please refer to the assembly position of the fixed and movable elements shown in the figure above.

Fig.7

Type	Size	Length L [mm]	Stroke H [mm]	$C_{Grad}$ [N]	C [mm]	N [mm]	E [mm]	Number of holes	Weight per single guide [kg]
HGT...MG	060	400	402	3930	200	-	-	8	4.3
		450	472	3955	250	-	-	8	4.9
		500	512	4678	300	-	-	8	5.5
		550	552	4994	350	150	50	12	6.0
		600	622	4849	400	175	50	12	6.6
		650	662	5204	450	200	50	12	7.2
		700	702	5527	500	225	50	12	7.8
		750	772	5389	550	250	50	12	8.3
		800	812	5665	600	275	50	12	8.9
		850	852	5913	650	300	50	12	9.5
		900	922	5771	700	325	50	12	10.0
		950	962	5736	750	350	50	12	10.7
		1000	1002	5534	800	375	50	12	11.2
		1100	1112	4973	900	425	50	12	12.4
		1200	1222	4488	1000	475	50	12	13.5
1300	1302	4105	1100	525	50	12	14.7		
1400	1412	3712	1200	575	50	12	15.8		
1500	1522	3378	1300	625	50	12	17.0		

\*Load capacity per pair.

Tab.6

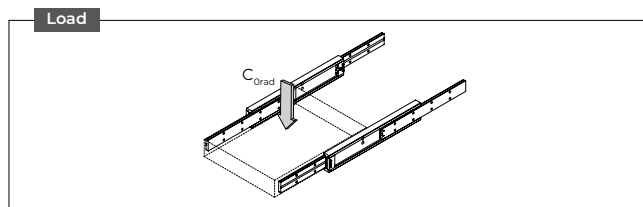

■ HGT080

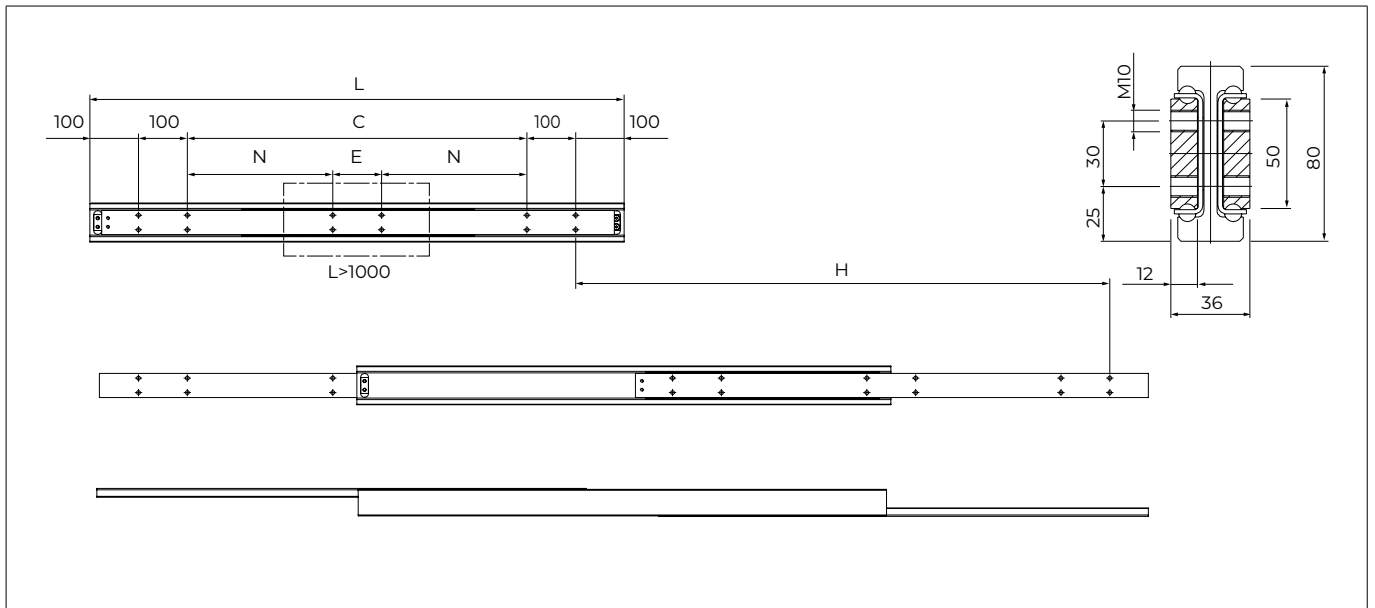
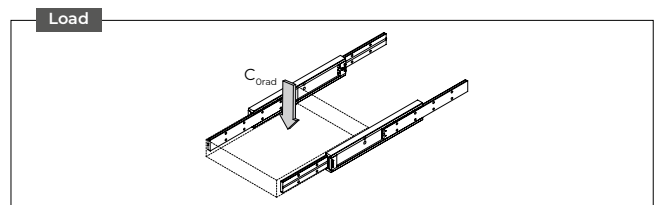

Fig.8

Type	Size	Length L [mm]	Stroke H [mm]	$C_{Grad}$ [N]	C [mm]	N [mm]	E [mm]	Number of holes	Weight per single guide [kg]
HGT	080	600	600	3062	200	-	-	8	10.2
		650	650	3251	250	-	-	8	11.1
		700	700	4063	300	-	-	8	12.0
		750	750	4040	350	-	-	8	12.9
		800	800	3999	400	-	-	8	13.7
		850	850	3938	450	-	-	8	14.6
		900	900	4220	500	-	-	8	15.5
		950	950	4067	550	-	-	8	16.4
		1000	1000	3916	600	-	-	8	17.3
		1100	1100	4662	700	300	100	12	19.1
		1200	1200	4465	800	350	100	12	20.8
		1300	1300	4380	900	400	100	12	22.6
		1400	1400	4169	1000	450	100	12	24.4
		1500	1500	4008	1100	500	100	12	26.1
		1600	1600	3807	1200	550	100	12	28.0
		1700	1700	3623	1300	600	100	12	29.7
		1800	1800	3443	1400	650	100	12	31.5
		1900	1900	3268	1500	700	100	12	33.3
2000	2000	3116	1600	750	100	12	35.1		

\*Load capacity per pair

Tab.7



■ HGTX080 stainless steel

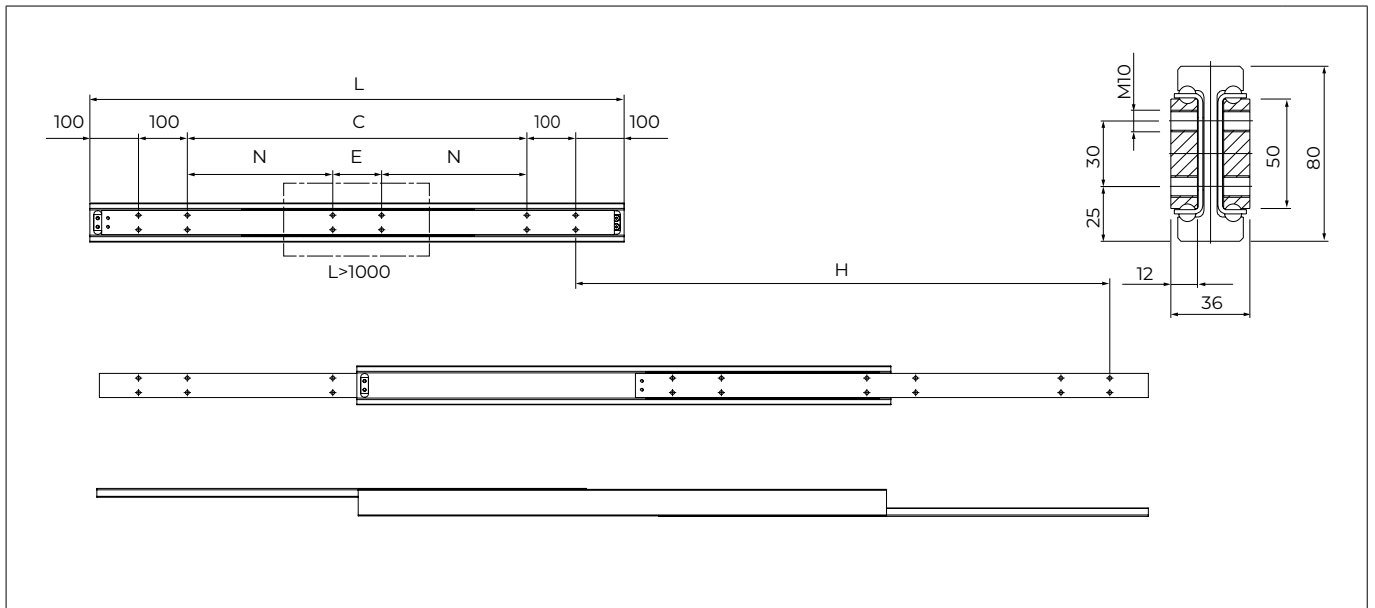

Rail, sliders, and ball cages are made of stainless steel AISI 304. The balls are made of stainless steel AISI 420C.

Fig.9

Type	Size	Length L [mm]	Stroke H [mm]	$C_{Orad}$ [N]	C [mm]	N [mm]	E [mm]	Number of holes	Weight per single guide [kg]
HGTX	080	600	600	3062	200	-	-	8	10.2
		650	650	3250	250	-	-	8	11.1
		700	700	3873	300	-	-	8	12.0
		750	750	3843	350	-	-	8	12.9
		800	800	3790	400	-	-	8	13.7
		850	850	3722	450	-	-	8	14.6
		900	900	4026	500	-	-	8	15.5
		950	950	3881	550	-	-	8	16.4
		1000	1000	3745	600	-	-	8	17.3
		1100	1100	4588	700	300	100	12	19.1
		1200	1200	4409	800	350	100	12	20.8
		1300	1300	4380	900	400	100	12	22.6
		1400	1400	4169	1000	450	100	12	24.4
		1500	1500	4008	1100	500	100	12	26.1
		1600	1600	3807	1200	550	100	12	28.0
		1700	1700	3623	1300	600	100	12	29.7
		1800	1800	3443	1400	650	100	12	31.5
1900	1900	3268	1500	700	100	12	33.3		
2000	2000	3116	1600	750	100	12	35.1		

\*Load capacity per pair

Tab.8

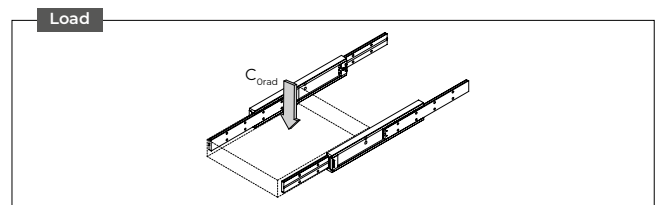

■ HGT080MG

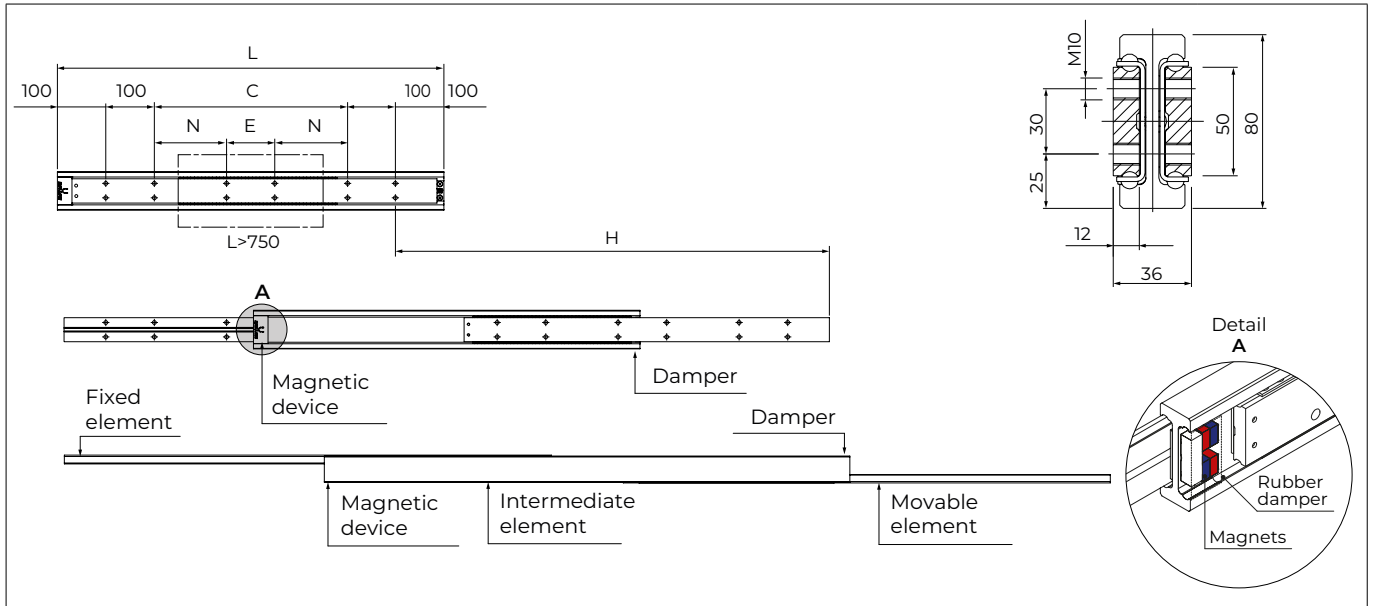

For installation in the application, please refer to the assembly position of the fixed and movable elements shown in the figure above.

Fig.10

Type	Size	Length L [mm]	Stroke H [mm]	$C_{\text{Grad}}$ [N]	c [mm]	N [mm]	E [mm]	Number of holes	Weight per single guide [kg]
HGT...MG	080	500	512	5764	100	-	-	8	8.3
		550	552	6545	150	-	-	8	9.3
		600	622	6326	200	-	-	8	10.1
		650	662	6779	250	-	-	8	11.0
		700	702	7207	300	-	-	8	11.9
		750	772	7019	350	-	-	8	12.8
		800	812	7229	400	150	100	12	13.6
		850	852	7525	450	175	100	12	14.5
		900	922	7349	500	200	100	12	15.4
		950	962	7615	550	225	100	12	16.3
		1000	1002	7835	600	250	100	12	17.2
		1100	1112	7600	700	300	100	12	19.0
		1200	1222	6963	800	350	100	12	20.7
		1300	1302	6470	900	400	100	12	22.5
		1400	1412	5950	1000	450	100	12	24.3
		1500	1522	5519	1100	500	100	12	26.0
		1600	1602	5134	1200	550	100	12	27.9
		1700	1712	4770	1300	600	100	12	29.6
1800	1822	4449	1400	650	100	12	31.4		
1900	1902	4145	1500	700	100	12	33.2		
2000	2012	3851	1600	750	100	12	35.0		

\*Load capacity per pair

Tab.9

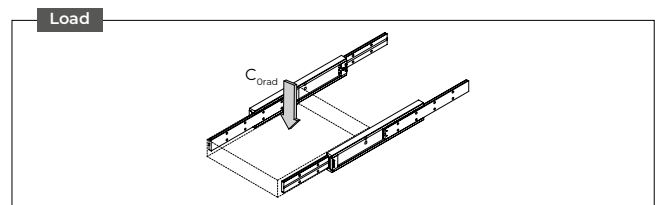

■ HGT100

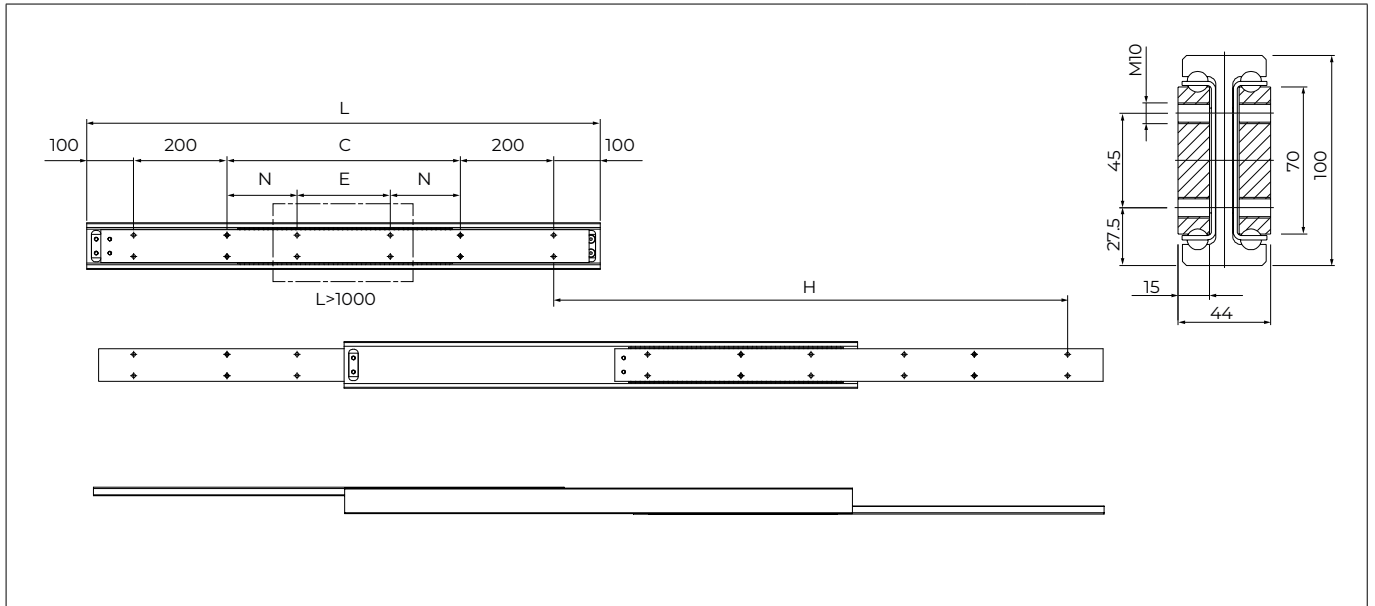
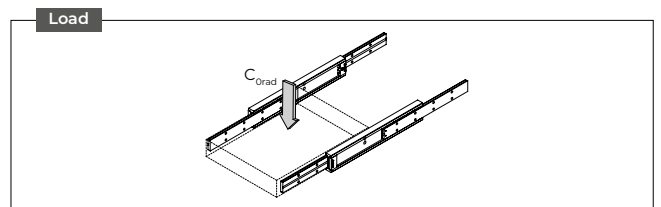

Fig.11

Type	Size	Length L [mm]	Stroke H [mm]	$C_{Orad}$ [N]	C [mm]	N [mm]	E [mm]	Number of holes	Weight per single guide [kg]
HGT	100	800	800	2909	200	-	-	8	21.6
		850	850	3626	250	-	-	8	22.9
		900	900	3692	300	-	-	8	24.4
		950	950	3730	350	-	-	8	25.8
		1000	1000	3743	400	-	-	8	27.2
		1100	1100	4230	500	150	200	12	30.0
		1200	1200	4180	600	200	200	12	32.8
		1300	1300	4329	700	250	200	12	35.6
		1400	1400	4195	800	300	200	12	38.4
		1500	1500	4193	900	350	200	12	41.3
		1600	1600	4020	1000	400	200	12	44.0
		1700	1700	3937	1100	450	200	12	46.9
		1800	1800	3765	1200	500	200	12	49.7
		1900	1900	3652	1300	550	200	12	52.6
2000	2000	3493	1400	600	200	12	55.4		

\*Load capacity per pair

Tab.10



■ HGTX100 stainless steel

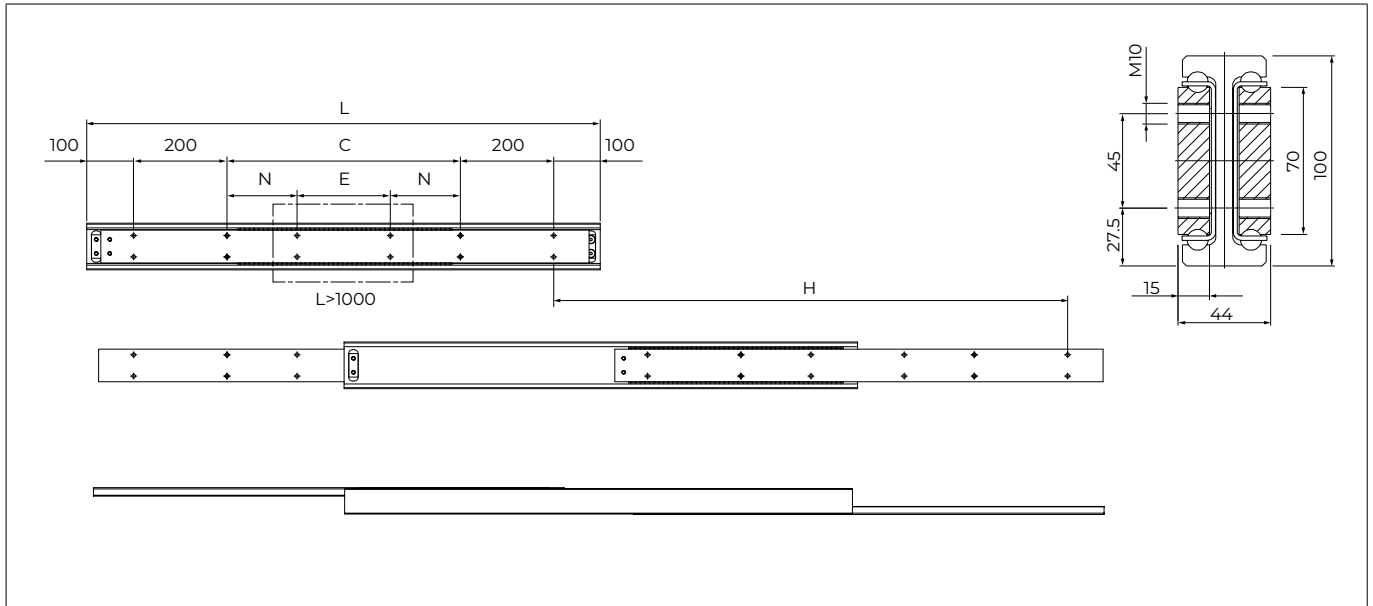

Rail, sliders, and ball cages are made of stainless steel AISI 304. The balls are made of stainless steel AISI 420C.

Fig.12

Type	Size	Length L [mm]	Stroke H [mm]	$C_{Grad}$ [N]	C [mm]	N [mm]	E [mm]	Number of holes	Weight per single guide [kg]
HGTX	100	800	800	2909	200	-	-	8	21.6
		850	850	3626	250	-	-	8	22.9
		900	900	3692	300	-	-	8	24.4
		950	950	3730	350	-	-	8	25.8
		1000	1000	3743	400	-	-	8	27.2
		1100	1100	4230	500	150	200	12	30.0
		1200	1200	4180	600	200	200	12	32.8
		1300	1300	4329	700	250	200	12	35.6
		1400	1400	4195	800	300	200	12	38.4
		1500	1500	4193	900	350	200	12	41.3
		1600	1600	4020	1000	400	200	12	44.0
		1700	1700	3937	1100	450	200	12	46.9
		1800	1800	3765	1200	500	200	12	49.7
		1900	1900	3652	1300	550	200	12	52.6
2000	2000	3493	1400	600	200	12	55.4		

\*Load capacity per pair

Tab.11

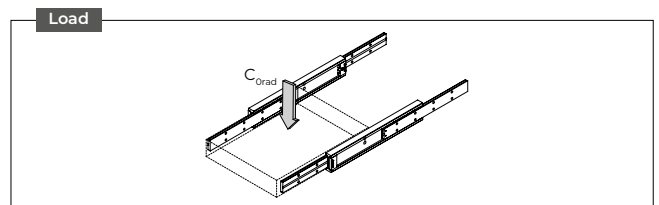

■ HGT120

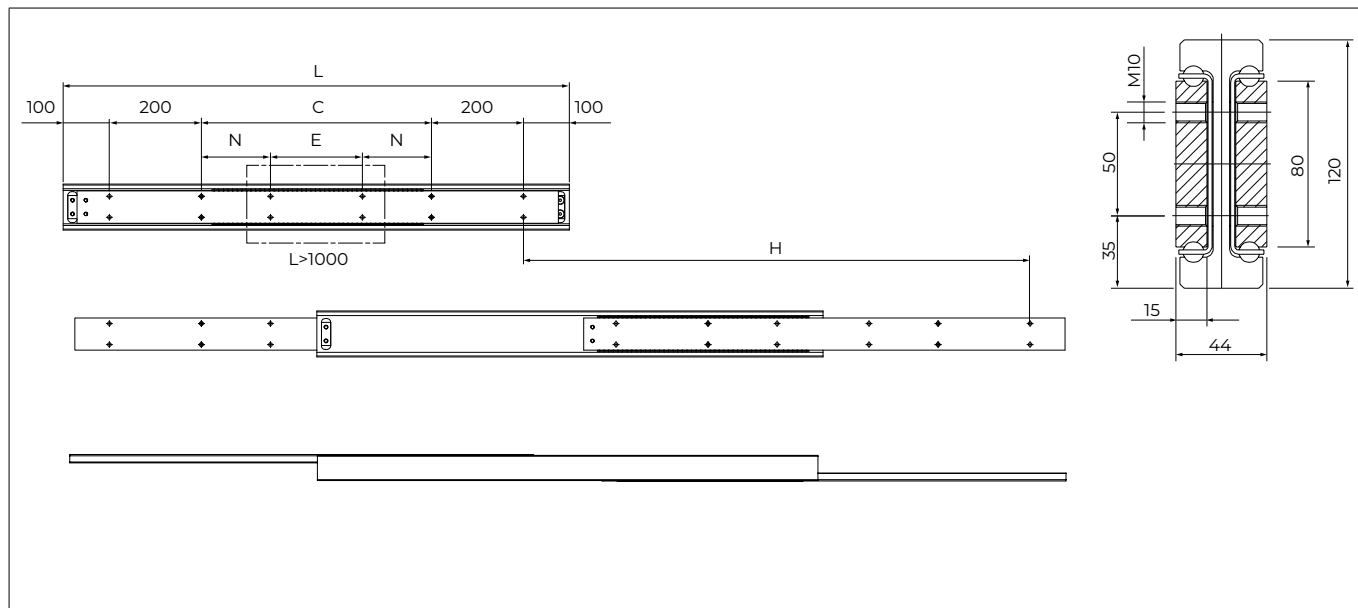
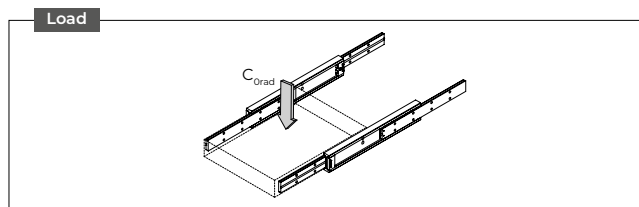

Fig.13

Type	Size	Length L [mm]	Stroke H [mm]	$C_{Orad}$ [N]	C [mm]	N [mm]	E [mm]	Number of holes	Weight per single guide [kg]
HGT	120	900	900	3669	300	-	-	8	30.1
		950	950	3781	350	-	-	8	31.8
		1000	1000	3870	400	-	-	8	33.5
		1100	1100	4605	500	150	200	12	37.0
		1200	1200	4654	600	200	200	12	40.4
		1300	1300	4984	700	250	200	12	43.9
		1400	1400	4925	800	300	200	12	47.4
		1500	1500	5081	900	350	200	12	50.9
		1600	1600	4964	1000	400	200	12	54.3
		1700	1700	4993	1100	450	200	12	57.8
		1800	1800	4845	1200	500	200	12	61.3
		1900	1900	4792	1300	550	200	12	64.8
2000	2000	4636	1400	600	200	12	68.2		

\*Load capacity per pair

Tab.12



■ HGTX120 stainless steel

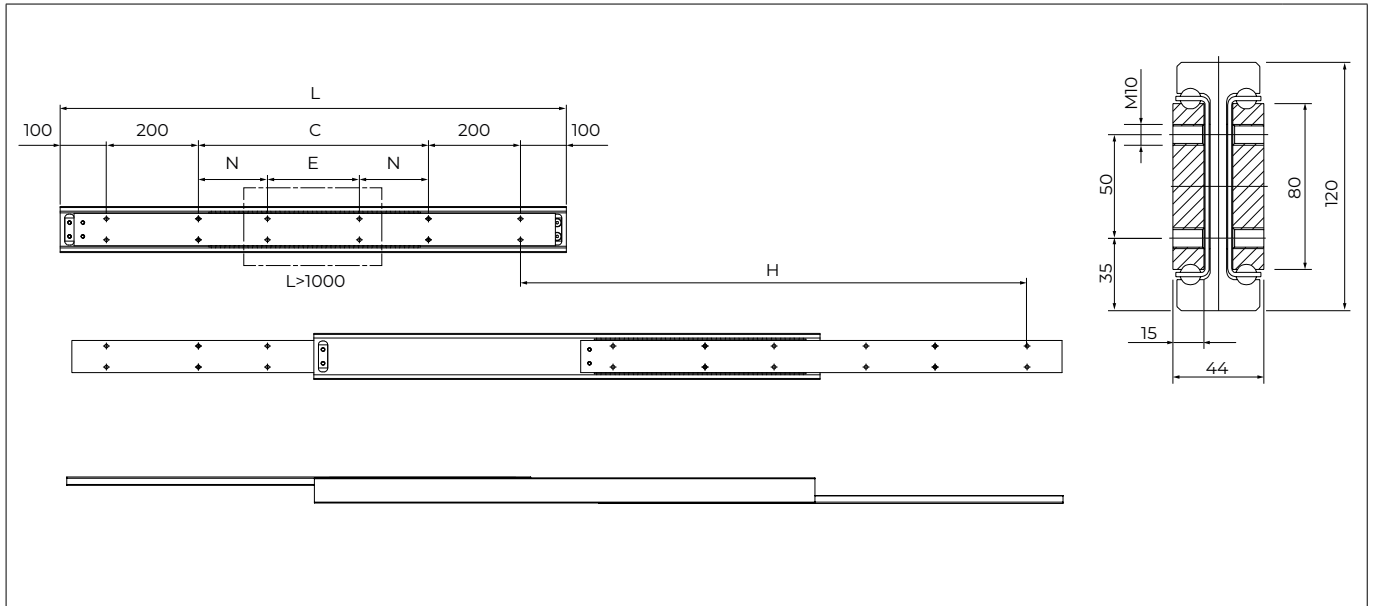

Rail, sliders, and ball cages are made of stainless steel AISI 304. The balls are made of stainless steel AISI 420C.

Fig.14

Type	Size	Length L [mm]	Stroke H [mm]	$C_{Orad}$ [N]	C [mm]	N [mm]	E [mm]	Number of holes	Weight per single guide [kg]
HGTX	120	900	900	3669	300	-	-	8	30.1
		950	950	3781	350	-	-	8	31.8
		1000	1000	3870	400	-	-	8	33.5
		1100	1100	4605	500	150	200	12	37.0
		1200	1200	4654	600	200	200	12	40.4
		1300	1300	4984	700	250	200	12	43.9
		1400	1400	4925	800	300	200	12	47.4
		1500	1500	5081	900	350	200	12	50.9
		1600	1600	4964	1000	400	200	12	54.3
		1700	1700	4993	1100	450	200	12	57.8
		1800	1800	4845	1200	500	200	12	61.3
		1900	1900	4792	1300	550	200	12	64.8
2000	2000	4636	1400	600	200	12	68.2		

\*Load capacity per pair

Tab.13

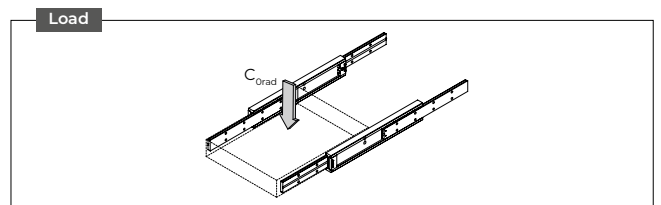

■ HGT150

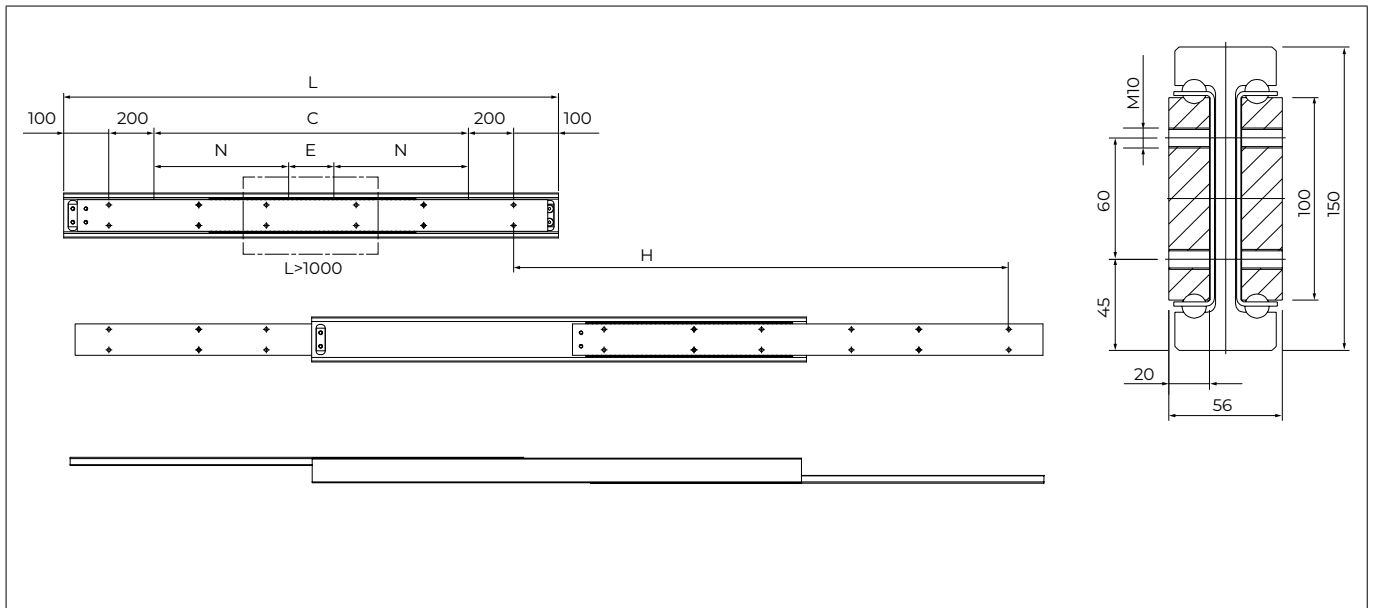
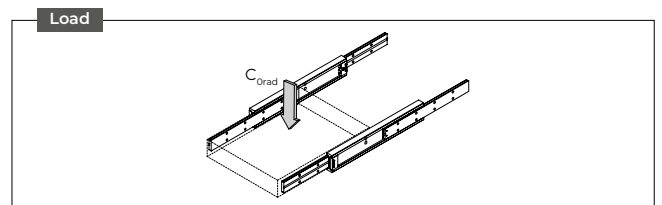

Fig.15

Type	Size	Length L [mm]	Stroke H [mm]	$C_{Orad}$ [N]	C [mm]	N [mm]	E [mm]	Number of holes	Weight per single guide [kg]
HGT	150	900	900	4231	300	-	-	8	48.3
		950	950	4590	350	-	-	8	51.2
		1000	1000	4938	400	-	-	8	53.9
		1100	1100	5569	500	150	200	12	59.4
		1200	1200	6044	600	200	200	12	65.0
		1300	1300	6357	700	250	200	12	70.6
		1400	1400	6593	800	300	200	12	76.2
		1500	1500	6787	900	350	200	12	81.8
		1600	1600	6925	1000	400	200	12	87.4
		1700	1700	7027	1100	450	200	12	93.0
		1800	1800	7096	1200	500	200	12	98.6
		1900	1900	7139	1300	550	200	12	104.2
2000	2000	7155	1400	600	200	12	109.8		

\*Load capacity per pair

Tab.14



■ HGTX150 stainless steel

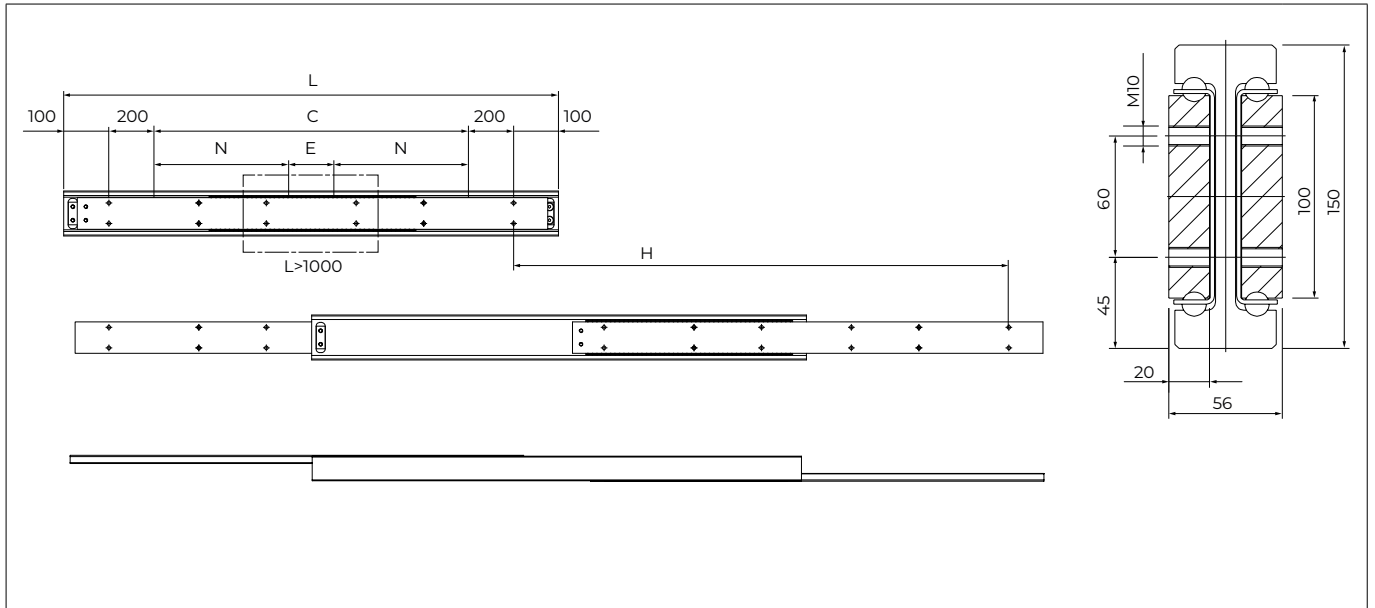

Rail, sliders, and ball cages are made of stainless steel AISI 304. The balls are made of stainless steel AISI 420C.

Fig.16

Type	Size	Length L [mm]	Stroke H [mm]	$C_{Orad}$ [N]	C [mm]	N [mm]	E [mm]	Number of holes	Weight per single guide [kg]
HGTX	150	900	900	3878	300	-	-	8	48.3
		950	950	4208	350	-	-	8	51.2
		1000	1000	4527	400	-	-	8	53.9
		1100	1100	5105	500	150	200	12	59.4
		1200	1200	5540	600	200	200	12	65.0
		1300	1300	5827	700	250	200	12	70.6
		1400	1400	6044	800	300	200	12	76.2
		1500	1500	6222	900	350	200	12	81.8
		1600	1600	6348	1000	400	200	12	87.4
		1700	1700	6441	1100	450	200	12	93.0
		1800	1800	6504	1200	500	200	12	98.6
		1900	1900	6544	1300	550	200	12	104.2
2000	2000	6559	1400	600	200	12	109.8		

\*Load capacity per pair

Tab.15

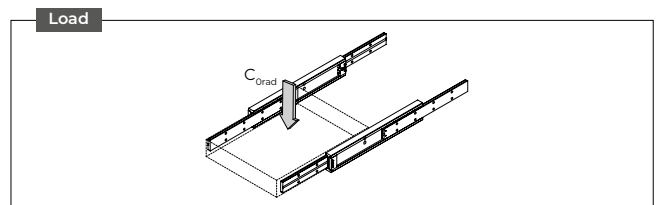

■ HGTX200 stainless steel

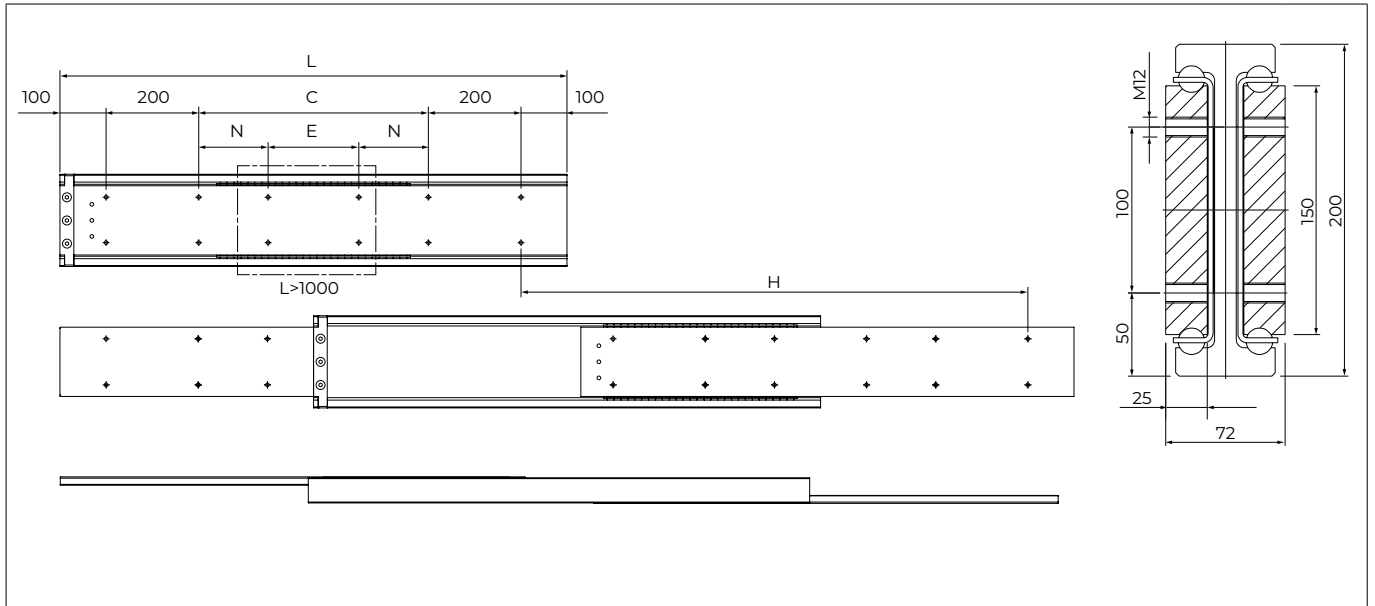

Rail, sliders, and ball cages are made of stainless steel AISI 304. The balls are made of stainless steel AISI 420C.

Fig.18

Type	Size	Length L [mm]	Stroke H [mm]	$C_{Orad}$ [N]	C [mm]	N [mm]	E [mm]	Number of holes	Weight per single guide [kg]
HGTX	200	900	900	4182	300	-	-	8	83.2
		950	950	4673	350	-	-	8	88.0
		1000	1000	5085	400	-	-	8	92.8
		1100	1100	5051	500	150	200	12	101.8
		1200	1200	5751	600	200	200	12	111.4
		1300	1300	6293	700	250	200	12	120.9
		1400	1400	6127	800	300	200	12	130.0
		1500	1500	6483	900	350	200	12	139.7
		1600	1600	6780	1000	400	200	12	149.2
		1700	1700	6614	1100	450	200	12	158.4
		1800	1800	6843	1200	500	200	12	167.9
		1900	1900	7044	1300	550	200	12	177.5
2000	2000	6877	1400	600	200	12	186.6		

\*Load capacity per pair

Tab.17

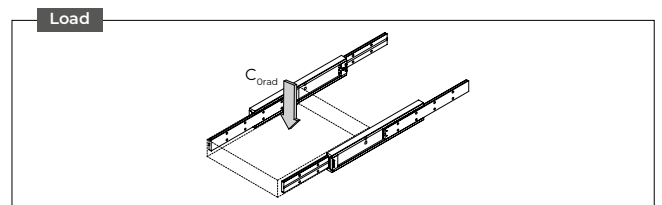

■ HGTX240 stainless steel

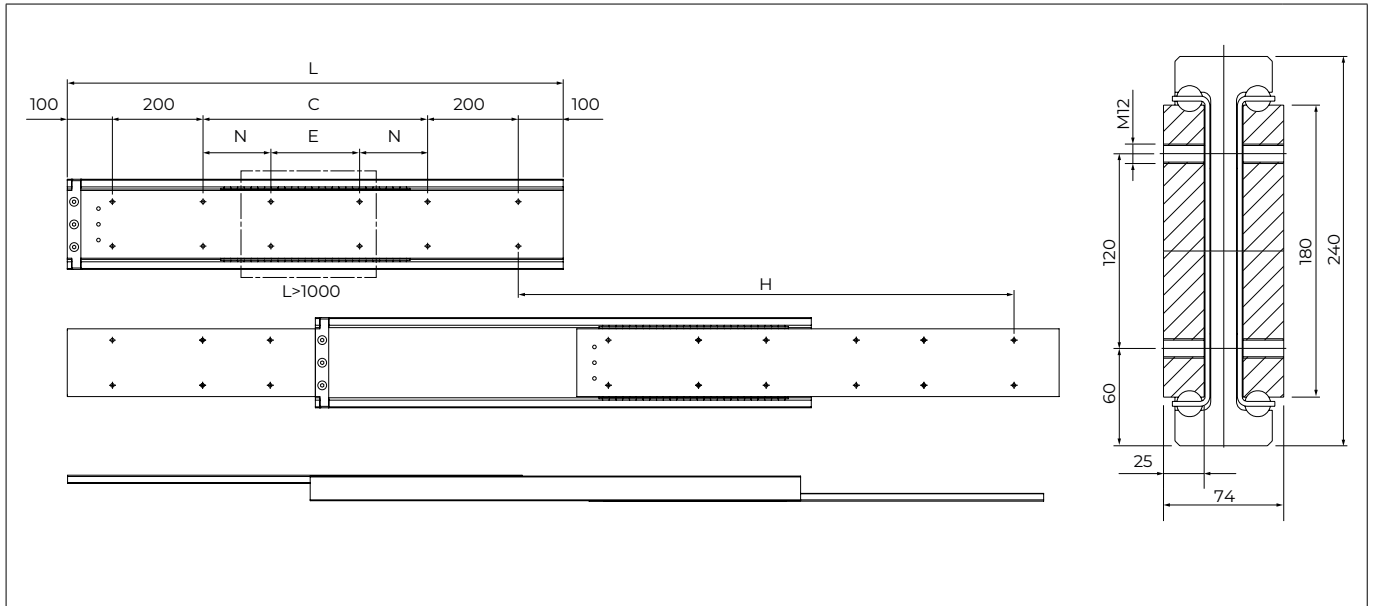

Rail, sliders, and ball cages are made of stainless steel AISI 304. The balls are made of stainless steel AISI 420C.

Fig.20

Type	Size	Length L [mm]	Stroke H [mm]	$C_{\text{Grad}}$ [N]	C [mm]	N [mm]	E [mm]	Number of holes	Weight per single guide [kg]
HGTX	240	1000	1000	4735	400	-	-	8	117.4
		1100	1100	4724	500	150	200	12	128.9
		1200	1200	5504	600	200	200	12	140.9
		1300	1300	6203	700	250	200	12	153.0
		1400	1400	6086	800	300	200	12	164.5
		1500	1500	6637	900	350	200	12	176.6
		1600	1600	7067	1000	400	200	12	188.6
		1700	1700	6919	1100	450	200	12	200.3
		1800	1800	7227	1200	500	200	12	212.3
		1900	1900	7499	1300	550	200	12	224.3
		2000	2000	7339	1400	600	200	12	235.9

\*Load capacity per pair

Tab.19

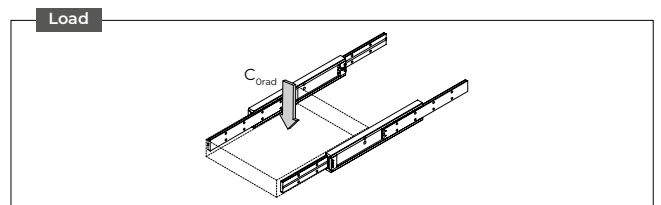

## ▶ ACCESSORIES

Accessories are available as options. They are integrated directly into the rails, and their code must be specified in the ordering code (see page 4).

### ■ Locking mechanisms (VG, VO, VB)

Locking mechanisms make it possible to lock the HGT rails in the open, closed, or both positions. This prevents inadvertent extension or retraction of the rail in any case. This ensures personal safety and protection of materials, especially in moving installations, such as vehicles. To unlock the position, the latch must be pressed.

For models with locking please refer to right or left side use.

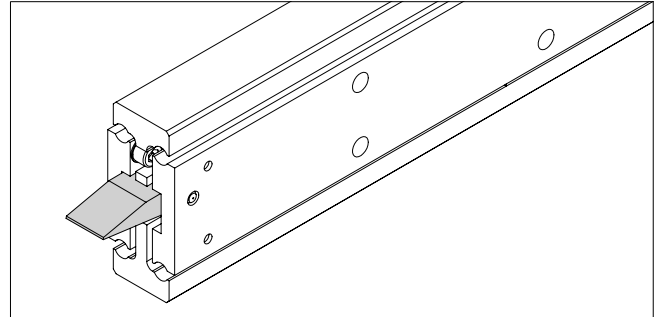

Fig.21

### ■ Driving disc (BM)

In the full-extension rails with dual stroke the intermediate element does not follow a particular order. The exact position of the element is therefore defined only in fully extended condition. The optional driving disc defines the movement of the intermediate element.

This prevents unwanted protrusion of the element. An example of the use of the driving disc is in warehouse rails, which extend in both directions.

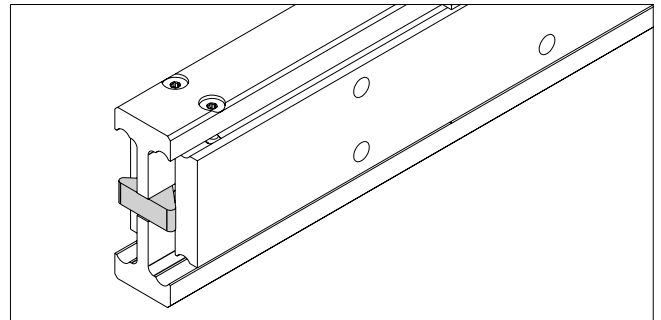

Fig.22

### ■ Damping elements (DG)

HGT telescopic rails can be fitted with damped end-stops in the closed position. The plastic or elastomer damping elements contribute to smoother and quieter operation, reducing impact when closing and increasing resistance at the end of the stroke.

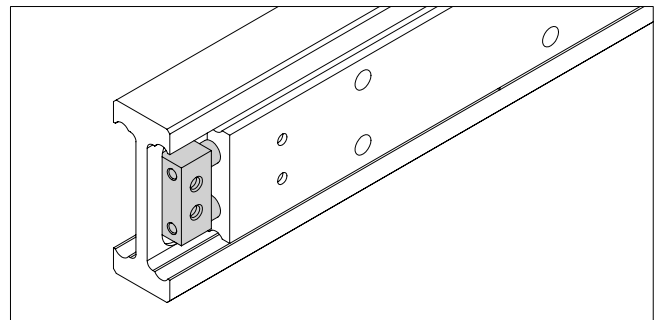

Fig.23

### ■ Snap-lock mechanisms (EG, EO, EB)

HGT telescopic rails can be configured with a snap-lock mechanism. It prevents accidental movement from the desired position (closed, open, or both). It operates through ball plungers that are pre-tensioned by a spring. To unlock the position, sufficient force must be applied to the slide to overcome the spring resistance holding the ball in its seat.

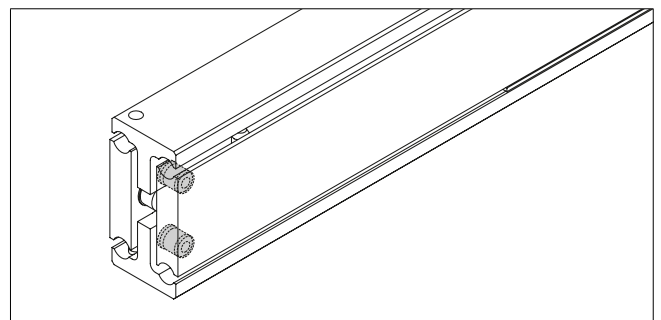

Fig.24

■ Accessories overview

Type	Size	Locking mechanisms*			Double stroke with driving disc (BM)	Damping elements closed position (DC)	Snap-lock mechanisms		
		Closed position (VG)	Opened position (VO)	Both position (VB)			Closed position (EC)	Opened position (EO)	Both position (EB)
HGT	060	●	●	●	●	●	●	●	●
	080	●	●	●	●	●	▲	▲	▲
	100	●	-	●	●	●	-	-	-
	120	-	-	-	●	-	-	-	-
	150	-	-	-	●	-	-	-	-
HGTX	030	-	-	-	●	●	●	●	●
	035	-	-	-	●	●	●	●	●
	060	●	●	●	●	●	●	●	●
	080	-	-	-	●	●	-	-	-
	100	●	-	-	●	●	-	-	-
	120	-	-	-	-	-	-	-	-
	150	-	-	-	-	-	-	-	-
	200	-	-	-	-	-	-	-	-
240	-	-	-	-	-	-	-	-	
HGT...MG	060	●	●	●	-	■	-	-	-
	080	●	●	●	-	■	-	-	-

Tab.20

■ Standard, ● Available, ▲ Available only for lengths up to 1000 mm.

\*The availability of locking mechanisms depends on the system length and varies by product group. For further information, please contact our technical department.

For models with locking mechanism (VG, VO, VB), please refer to right- or left-side use.

Not all accessories (EG/EO/EB, VG/VO/VB, DC, B, BM) can be combined with each other. Please contact our technical department if multiple options need to be combined.

## ▶ USE AND MAINTENANCE

### ■ Lubrication

Recommended lubrication intervals are heavily dependent on the ambient conditions, speed, and temperature. Under normal conditions, lubrication is recommended after 100 km of operational performance or after an operating period of six months. This prevents friction, protects the components and prolongs the life of the system. In critical applications, the interval should be shorter. Please clean the raceways carefully before lubricating. Raceways and spaces of the ball cage spaces are lubricated with a lithium lubricant of average consistency (roller bearing lubricant). HGT telescopic rails made of stainless steel are generally delivered without grease and they should be lubricated by the customer.

Different lubricants are available upon request for special applications:

- FDA-approved lubricant for use in the food industry.
- Specific lubricant for clean rooms.
- Specific lubricant for the marine technology sector.
- Specific lubricant for high- and low-temperature use.

For specific information, please contact our technical department.

### ■ Corrosion protection

As standard features, all series are zinc electroplated, thick-film passivated, and REACH/RoHS compliant. For higher corrosion protection we offer zinc nickel plating with stainless steel balls. Below is an overview of available coatings:

Treatment	Characteristics
Zinc plating DIN 50979	Standard coating composed of a galvanic zinc coating and an additional thick-film passivation
Zinc-nickel ISO 19598 (Z)	Increase corrosion resistance due to a zinc nickel coating and the use of stainless steel balls

Tab.21

### ■ Operating temperature

The HGT rails can be used at ambient temperatures from -20 °C to +170 °C (-4 °F to +338 °F). A lithium lubricant for high operating temperatures is recommended for temperatures above +130 °C (+266 °F). Minimum temperature with standard grease is -20 °C (-4 °F). At lower temperatures down to -30 °C (-22 °F) or higher temperatures above up to +250 °C (+482 °F), please contact our application engineers. These ranges always require the use of a special lubricant.

For HGT...MG max working temperatures 80 °C.

When damping (DG) is used, the operating temperature is -20 °C to + 50 °C (-4 °F to +122 °F).

### ■ Speed

The maximum operating speed is determined by the mass of the intermediate element, which moves with the movable rail. This reduces the maximum permissible operating speed with increasing length (Fig.25). Maximum acceleration: 0.6 m/s<sup>2</sup>

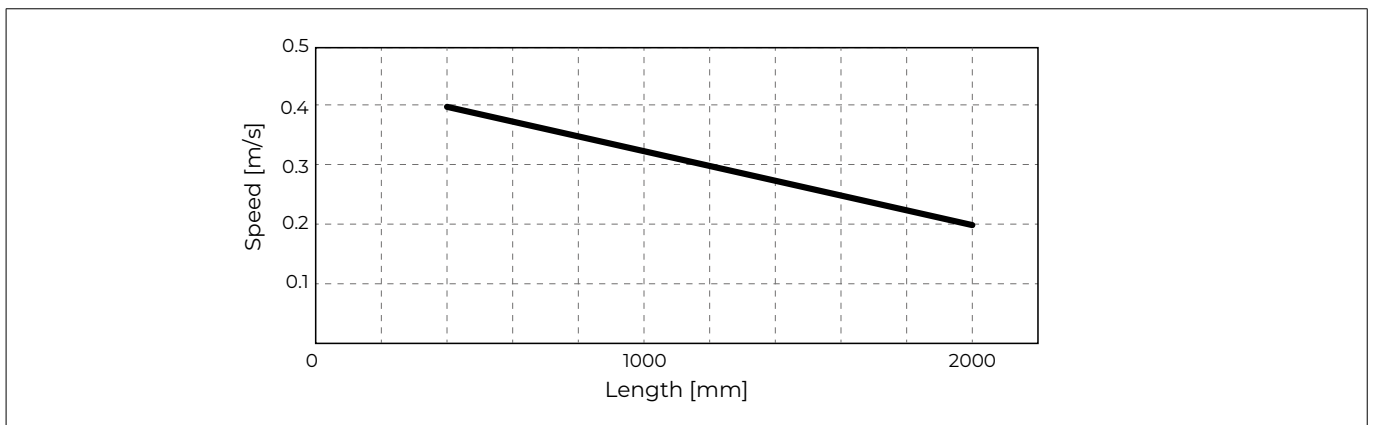

Fig.25

■ **Moving force**

The moving force is subject to production-related tolerances and is also defined by the load and the deflection of a telescopic rail. Taking into account the load and deflection of a telescopic rail, the closing force is higher than the opening force, since deflection occurs under load, and closing takes place by pushing against a slanted plane.

■ **Deflection**

When the load acts vertically on the pair of rails, the expected elastic deflection in the extended state can be determined as follows:

$$f = \frac{P}{1000} \cdot k$$

Whereby:

- f** Expected elastic deflection [mm]
- P** Actual load acting on the centre of a pair of rails [N]
- k** Coefficient based on the rail length (see following graphs)

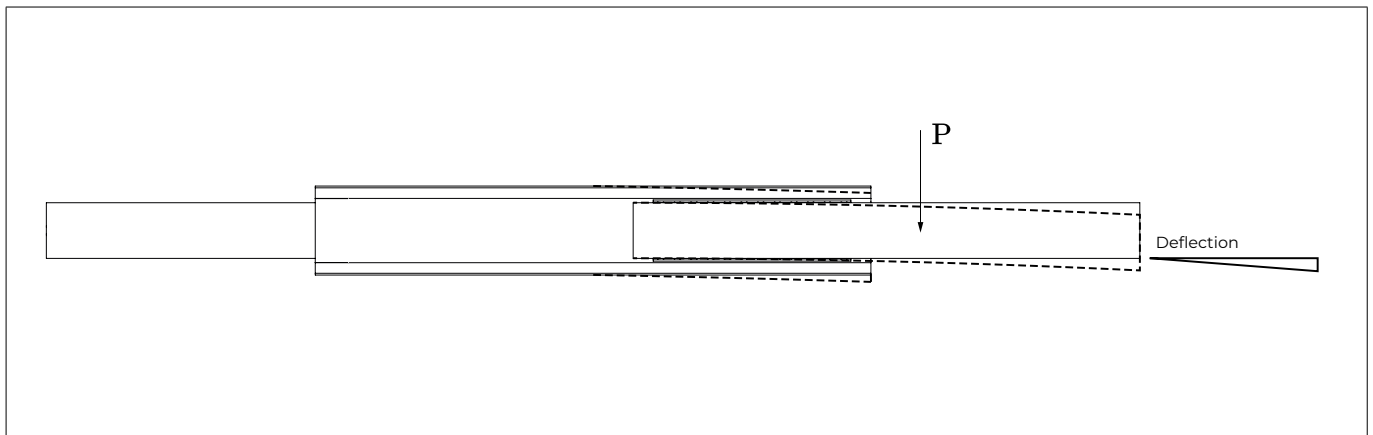

Fig.26

This estimated value assumes an absolutely rigid adjacent construction.  
If this rigidity is not present, the actual deflection will deviate from the calculation.

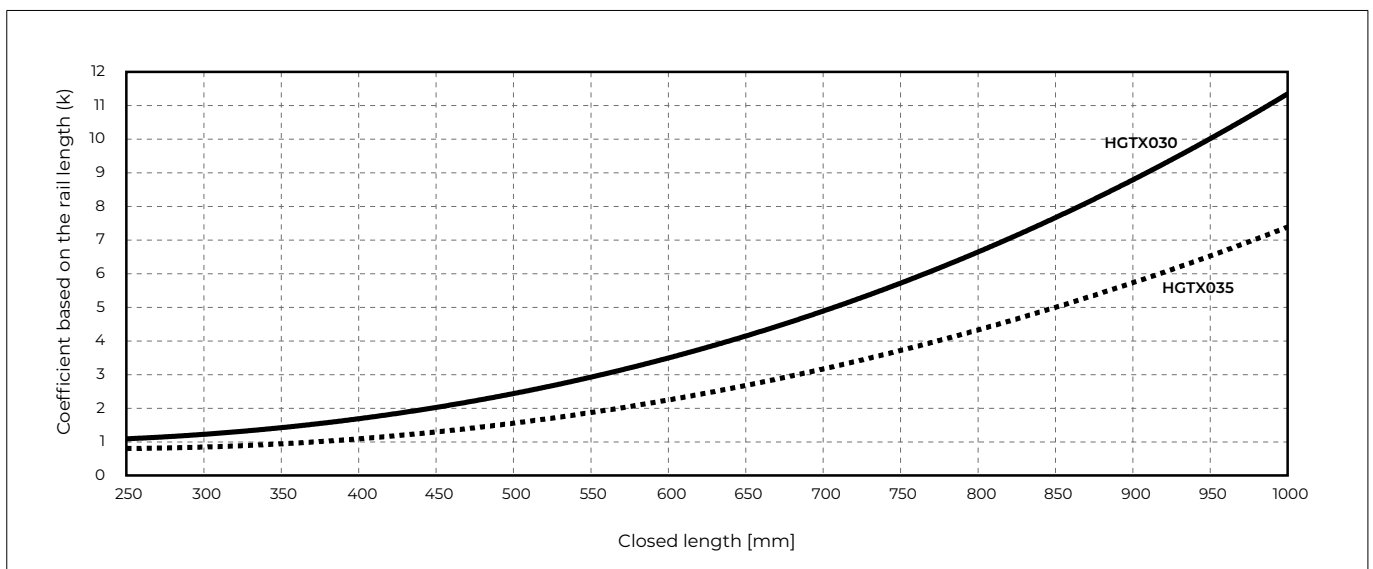

Fig.27

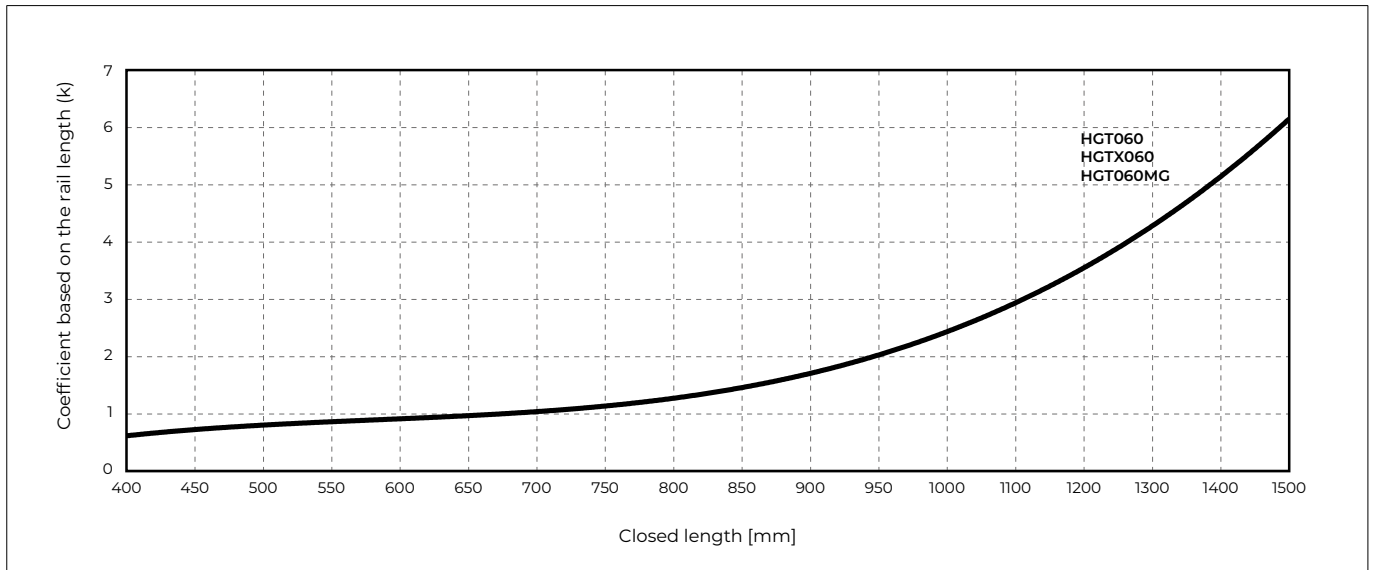

Fig.28

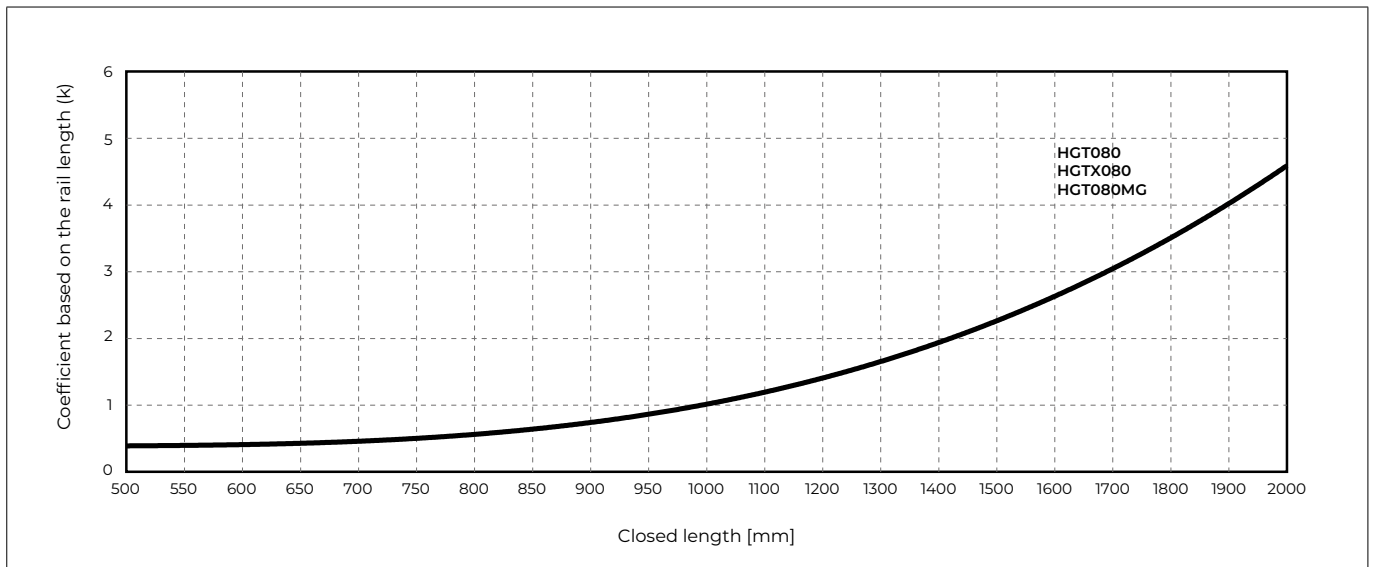

Fig.29

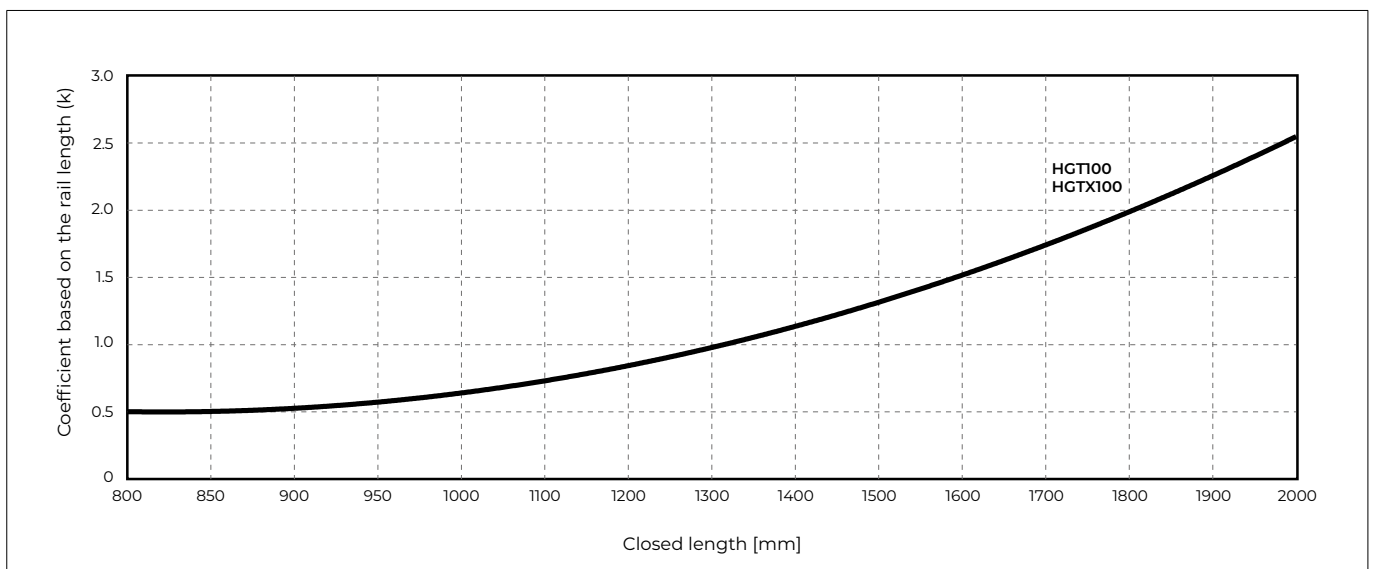

Fig.30



Fig.31

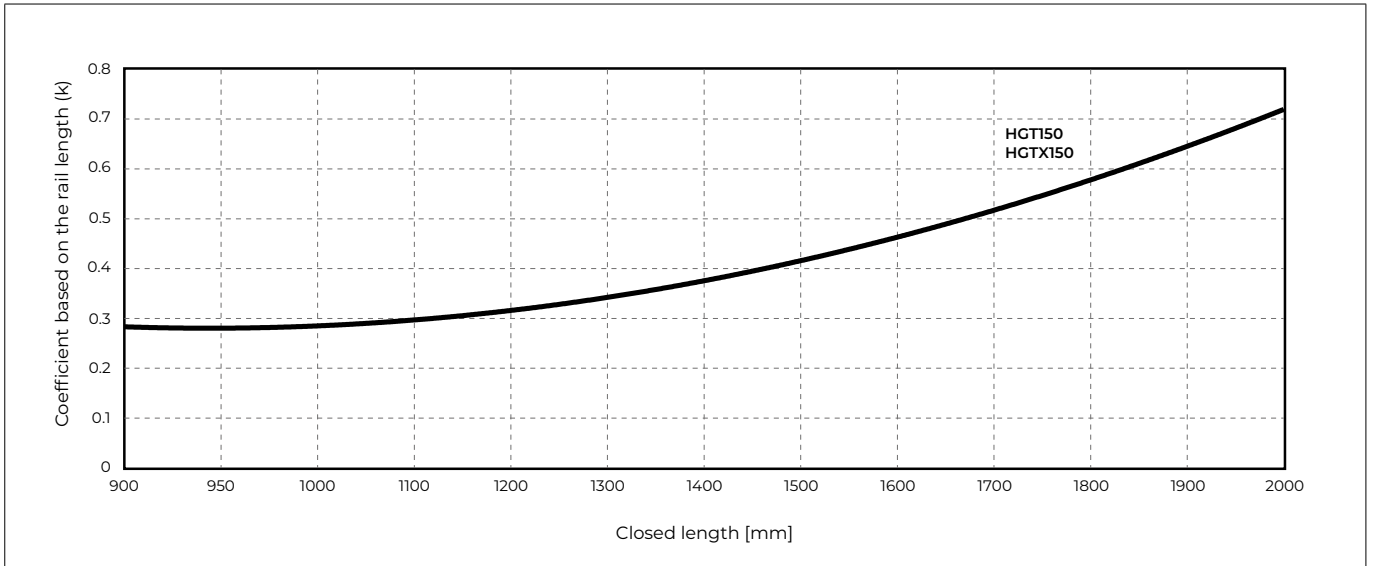

Fig.32

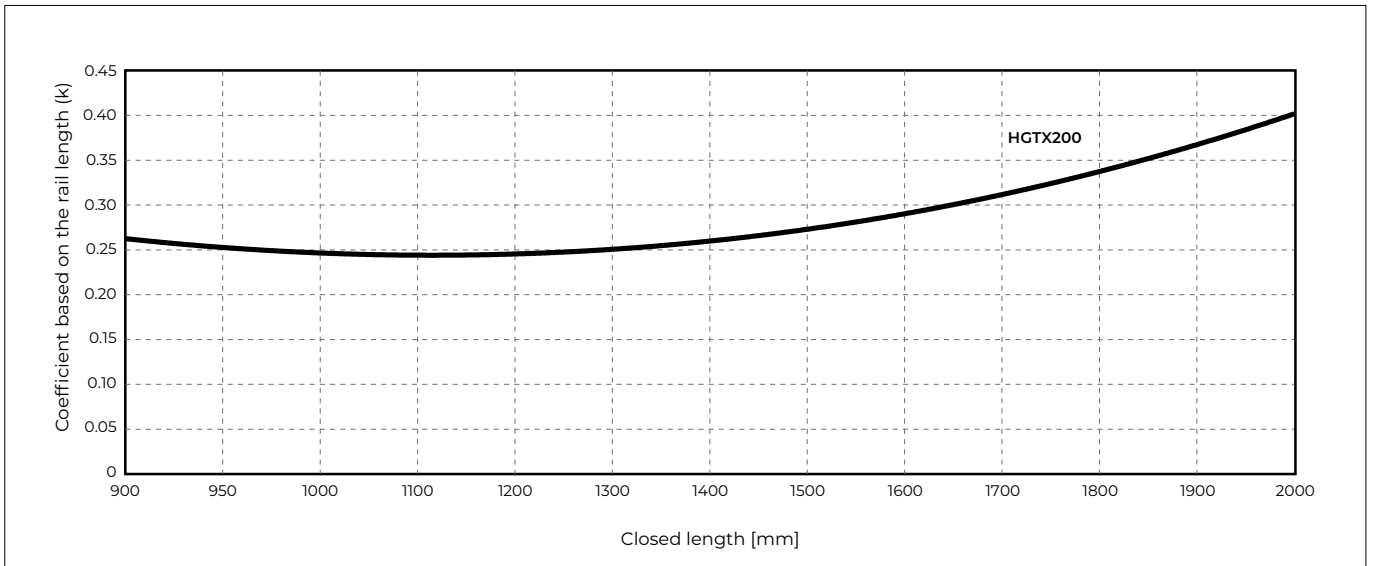

Fig.33

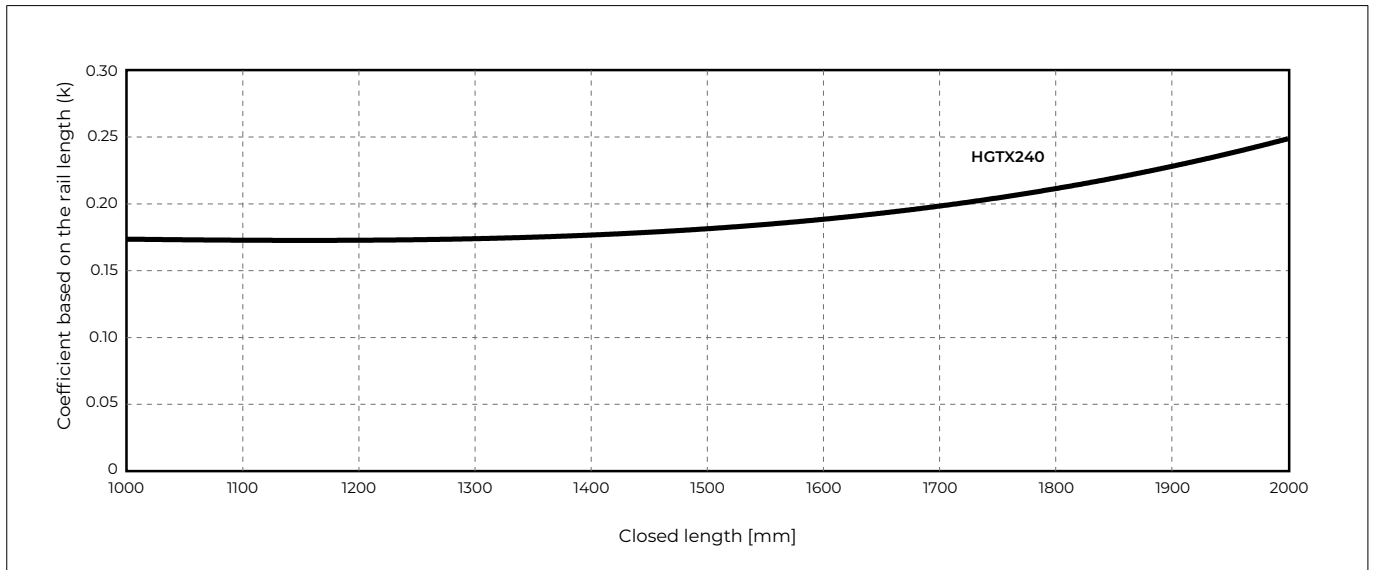

Fig.34

#### ■ Installation instructions

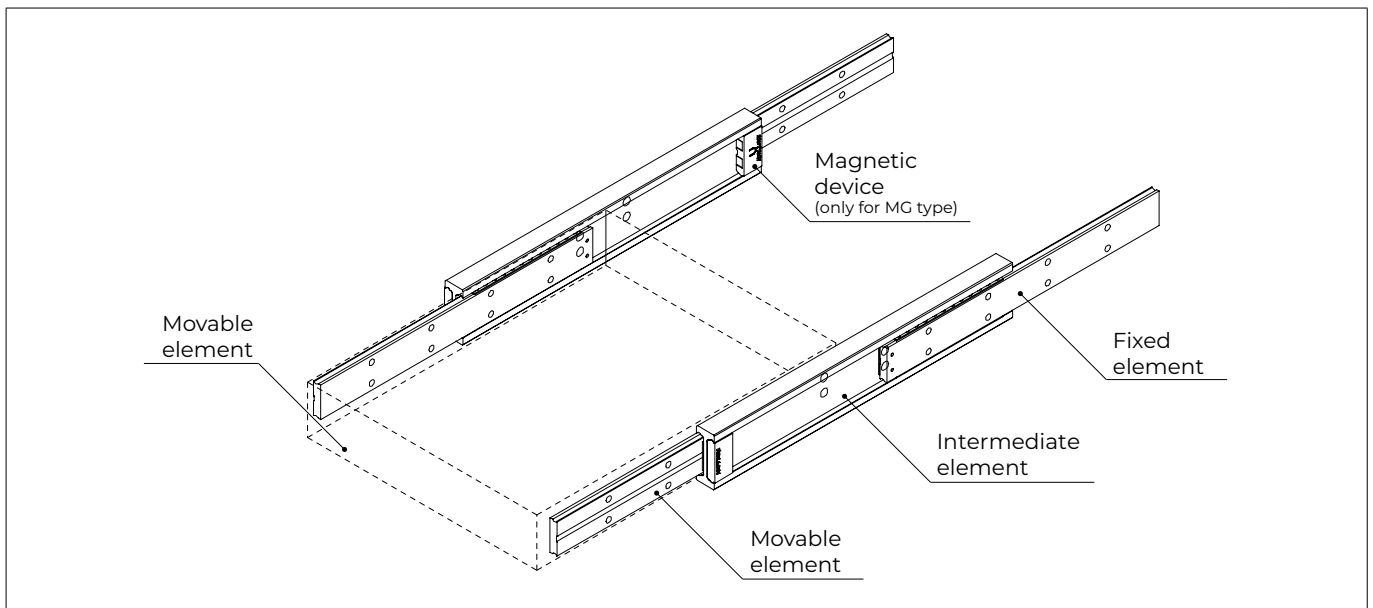

Fig.35

- ▣ To achieve optimum running properties and rigidity it is necessary to fix the telescopic rails with all fixing holes.
- ▣ Mounting of the telescopic rails on a flat and rigid surface using all provided mounting holes.
- ▣ Internal stops are used to stop the unloaded slider and the ball cage. Please use external stops as end stops for a loaded system
- ▣ For MG type respect the position of the Magnet device while assembling the rail on the application.

#### ■ Distance between the rails

For ideal operation, in applications where it is not possible to apply the opening force in proximity of both rails, it is recommended to maintain a maximum distance between the rails equal to 1.5 times the length of the rails.

■ **Mounting holes**

Please use all mounting holes. Please be sure to use the correct screw length to prevent damage to the ball cage: shank length of screw < thickness of the moving element; see the table below.

Type	Size	M	Max. A [mm]
HGT	030	M6	7
	035	M6	9
	060	M6	9*
	080	M10	11
	100	M10	14
	120	M10	14
	150	M10	19
	200	M12	24
	240	M12	24

\*For HGT060 option VG, VO, VG dimension A = 7 mm

Tab.22

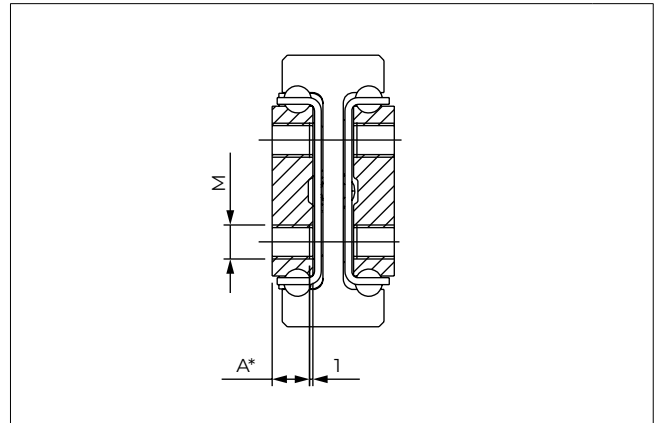

\*Maintain a safe distance to avoid screw protrusion and cage jamming. Fig.36

■ **Ball cage displacement**

The movement of the telescopic rails is enabled by internal ball cages, which may experience an offset from the original position. This phase offset can have a negative effect on the running properties or limit the stroke. The drive force must be sufficiently dimensioned to appropriately synchronize the ball cage offset. Otherwise, an additional maximum stroke with no load must be planned regularly to ensure the correct position of the ball cage.

Higher risk of cage displacement when the stroke is in the vertical direction, we do not recommend vertical use. For further information, please contact our technical department.

■ **Special strokes**

Special strokes are defined as deviations from the standard stroke H. They are each available as multiples of the values in Tab.23.

These values are depend on the spacing of the ballcage.

Type	Size	Stroke modification [mm]
HGT	030	40
	035	40
	060	40
	060MG	30
	080	40
	080MG	30
	100	40
	120	40
	150	50
	200	60
	240	60

Tab.23

## ▣ STATIC LOAD

The values in the load capacity tables of the corresponding series (see Components and Dimensions, pg.7) indicate the maximum permissible load of a pair of rails at the middle of the two rails and along the centerline of the moving element, with the rails in the completely extended state and with the vertical installation of the cross section.

Using a pair of rails, the load acts in the center on rails (see Fig.37, P). The load capacity of a rail pair is:  $C_{0rad}$

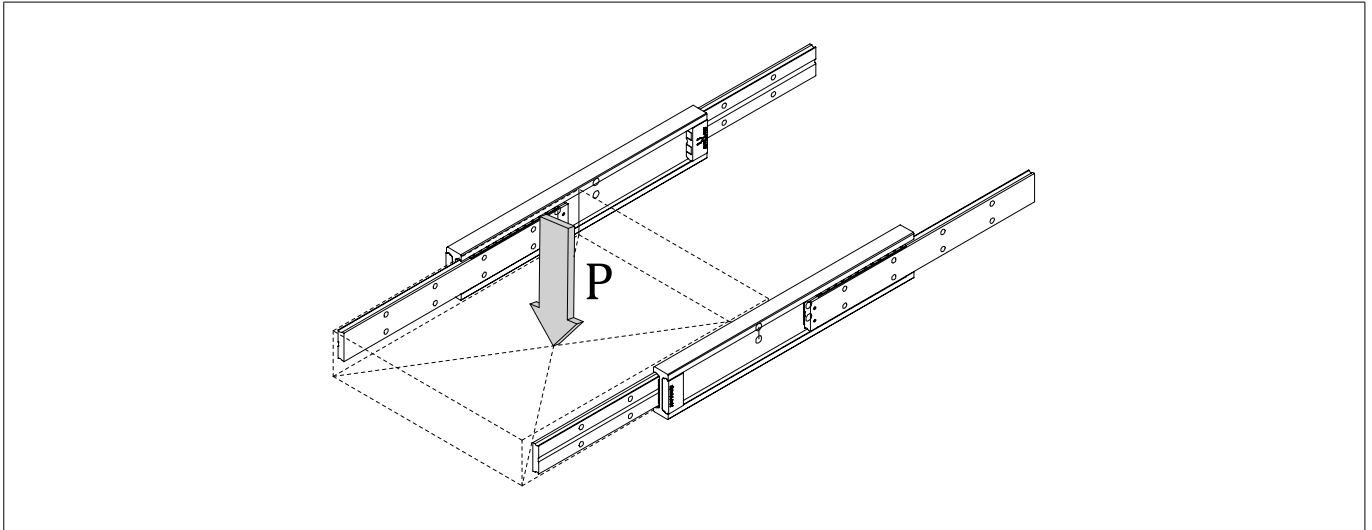

Fig.37

In the case of horizontal installation of the telescopic rails (axial load direction), only a reduced value of the radial load capacity is possible. For further information, please contact our technical department.

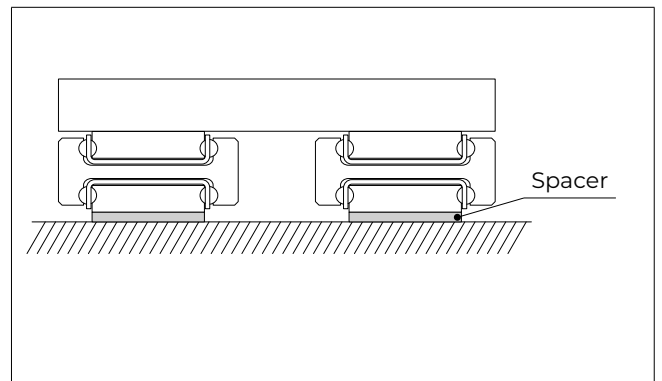

Fig.38



The content of this document and its use are subject to the general terms of sale of ROLLON available on the web site [www.rollon.com](http://www.rollon.com)

[rollon.com](http://rollon.com)