

WE SHAPE MOTION.



Gearbox brochure

E

Economy Line coaxial gearboxes



PLE



PLQE



PLPE



PLHE



PLFE



PFHE

E

Economy Line right angle gearboxes



WPLE



WPLQE



WPLPE



WPLHE



WPLFE

P

Precision Line coaxial gearboxes



PSNpro



PSFNpro



PSBNpro



PSN



PSFN



PSBN



PLN



PLFN

P

Precision Line right angle gearboxes



WPLN



WPSFN



WGN



Rack and pinion



NRS

PK1



PM1



PM2



Application-specific gearboxes

Custom made gearboxes



HLAE



NGV

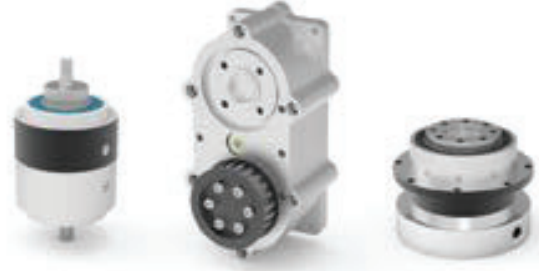

NDF









NDFC

Economy Line coaxial gearbox

PLE



The **PLE** is our price/performance wonder. It is particularly lightweight, extremely powerful and yet still suitable for demanding production cycles thanks to its low-friction bearing concept and optimized lubrication. A real powerhouse at an attractive and fair price.

-  Economy Line
-  Spur gear
-  Round type output flange
-  Low-friction deep groove ball bearings
-  High ratio variety $i=3$ up to $i=512$
-  Planet carrier in disc design
-  Option: Painted surface – RAL 9005 Jet black

Cyclic torque **5 - 800 Nm**

Radial force **200 - 5000 N**

Axial force **240 - 11000 N**

Torsional backlash **6 - 22 arcmin**

Protection class **IP54**

Frame sizes

- | | | | | |
|----|----|----|-----|-----|
| 40 | 60 | 80 | 120 | 160 |
|----|----|----|-----|-----|





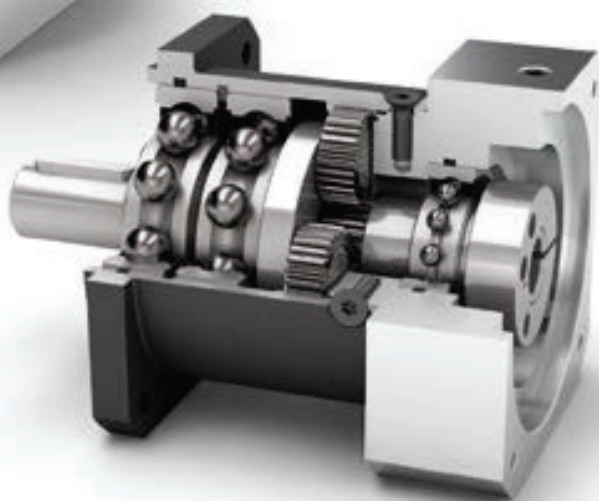

Economy Line coaxial gearbox

PLQE



Our **PLQE** is uncomplicated and powerful. It can be connected directly to your installation without the need for an intermediate flange. The larger deep groove ball bearings on the output allow higher axial and radial forces to be absorbed. Thanks to its favorable efficiency, this means that it always operates reliably even when production cycles are demanding.



-  Economy Line
-  Spur gear
-  Square type output flange
-  Reinforced deep groove ball bearings
-  High ratio variety $i=3$ up to $i=512$
-  Planet carrier in disc design
-  Option: Painted surface – RAL 9005 Jet black

Cyclic torque **5 - 260 Nm**



Radial force **520 - 4000 N**



Axial force **620 - 3800 N**



Torsional backlash **7 - 22 arcmin**



Protection class **IP54**



Frame sizes









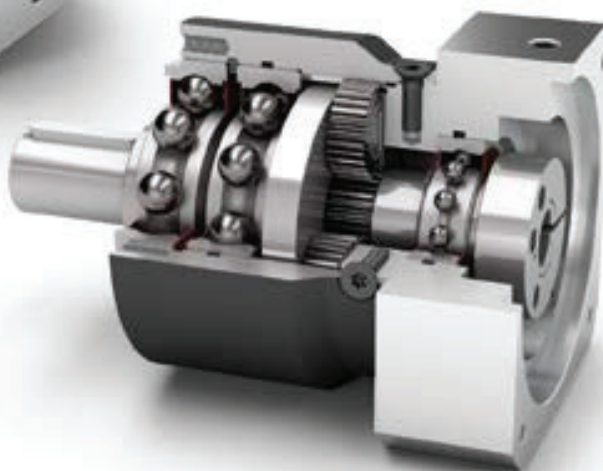

Economy Line coaxial gearbox

PLPE



Our **PLPE** combines the best features of the Economy series with a performance bonus: The optimized output bearing is designed for higher radial and axial forces. The compact outer contour of the **PLPE** also allows it to be used in limited spaces.



-  Economy Line
-  Spur gear
-  Round type output flange
-  Reinforced deep groove ball bearings
-  Planet carrier in disc design
-  Option: Rack and pinion
-  Option: Painted surface – RAL 9005 Jet black

Cyclic torque **5- 460 Nm**



Radial force **1300 - 8400 N**



Axial force **1000 - 11000 N**



Torsional backlash **6 - 19 arcmin**



Protection class **IP54**



Frame sizes



Economy Line coaxial gearbox

PLHE



The **PLHE** is our ideal combination of economy and precision gearboxes. The preloaded tapered roller bearings of this planetary gearbox guarantee high rigidity even under maximum load. The high-performance seal provides increased protection against dust and water spray.

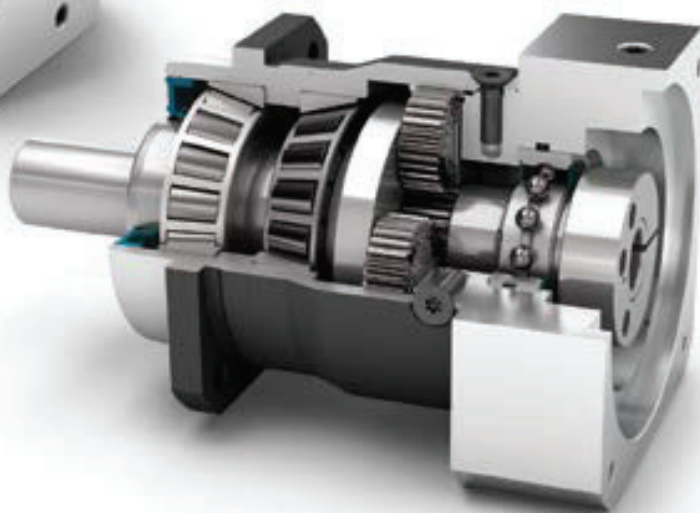

Economy Line



Spur gear



Square type output flange



Preloaded tapered roller bearings



Rotary shaft seal



Extra long centering collar



Planet carrier in disc design



Option: Rack and pinion



Option: Painted surface – RAL 9005 Jet black

Cyclic torque **15 - 260 Nm**



Radial force **3200 - 6000 N**



Axial force **4400 - 8000 N**

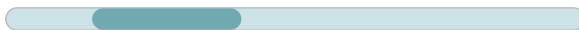

Torsional backlash **7 - 12 arcmin**

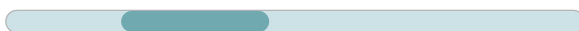

Protection class **IP65**



Frame sizes

60

80

120

Economy Line coaxial gearbox

PLFE

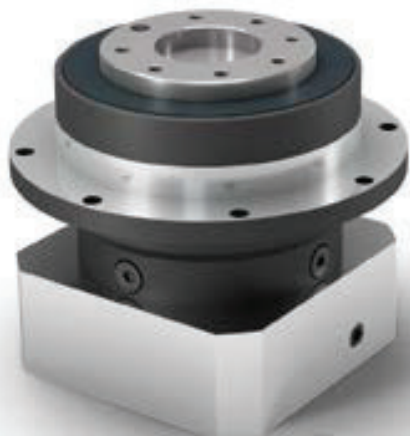

There is no such thing as too short: The **PLFE** is our planetary gearbox with compact flange output shaft. They are more than one-third smaller in size. Its standardized flange interface makes it particularly easy to install. The integrated dowel pin drill hole provides additional stability during installation.



-  Economy Line
-  Spur gear
-  Extra large round type output flange
-  Low-friction deep groove ball bearings
-  Flange output shaft (ISO 9409-1)
-  Planet carrier in disc design
-  Option: Painted surface – RAL 9005 Jet black

Cyclic torque **5 - 260 Nm**



Radial force **900 - 3800 N**



Axial force **1000 - 5200 N**



Torsional backlash **7 - 19 arcmin**



Protection class **IP54**



Frame sizes

55	64	90	110
----	----	----	-----

Economy Line coaxial gearbox

PFHE

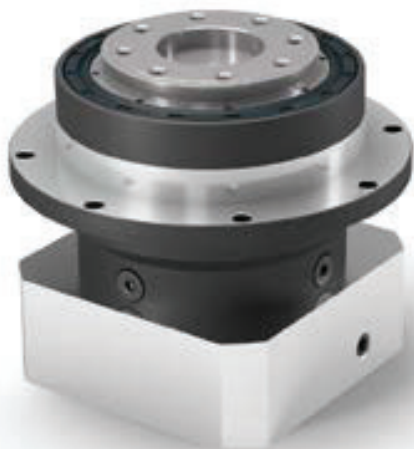

The **PFHE** represents an economically attractive alternative for high-load applications in which high radial loads occur. The combination of special pre-stressed inclined roller bearings and a flanged output shaft in accordance with ISO 9409-1 gives the **PFHE** a very high load capacity. Thanks to the radial shaft seal that is used, this gearbox achieves protection class IP65 at the output side and can therefore also withstand adverse usage conditions.



Economy Line



Spur gear



Extra large round type output flange



Preloaded angular contact roller bearings



Rotary shaft seal



Flange output shaft (ISO 9409-1)



Planet carrier in disc design



Option: Rack and pinion



Option: Painted surface – RAL 9005 Jet black

Cyclic torque **15 - 260 Nm**



Radial force **2300 - 5150 N**



Axial force **2850 - 6450 N**

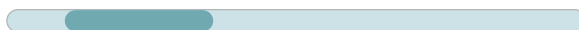

Torsional backlash **7 - 12 arcmin**



Protection class **IP65**



Frame sizes

64

90

110

Economy Line right angle gearbox

WPLE

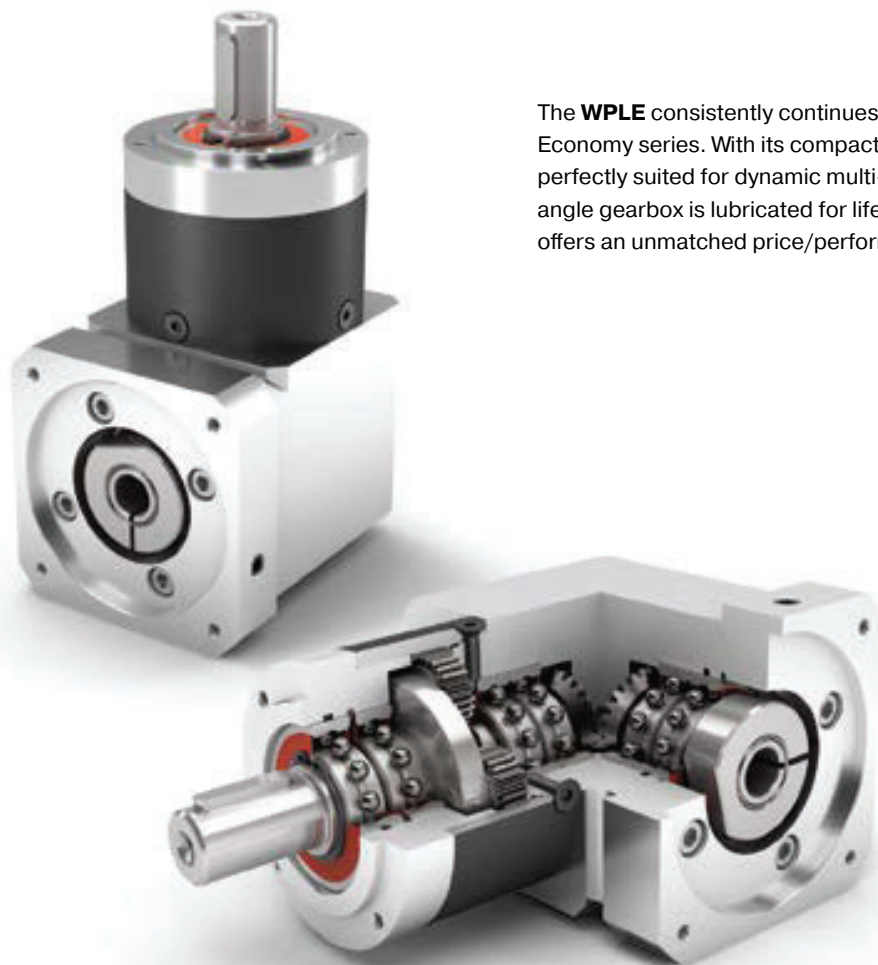

The **WPLE** consistently continues the advantages of the Economy series. With its compact but powerful design, it is perfectly suited for dynamic multi-axis systems. Our right-angle gearbox is lubricated for life, easy to mount and offers an unmatched price/performance ratio.



Economy Line



Spur gear



Bevel gear right angle stage



Round type output flange



Low-friction deep groove ball bearings



High ratio variety $i=3$ up to $i=512$



Planet carrier in disc design



Option: Painted surface – RAL 9005 Jet black

Cyclic torque **5 - 260 Nm**



Radial force **200 - 2000 N**



Axial force **240 - 3800 N**



Torsional backlash **11 - 28 arcmin**



Protection class **IP54**



Frame sizes







Economy Line right angle gearbox

WPLQE



Our **WPLQE** is the right-angle gearbox with a square output flange. This makes it particularly easy to mount, versatile and, thanks to its larger deep groove ball bearings, also suitable for higher radial and axial forces.

-  Economy Line
-  Spur gear
-  Bevel gear right angle stage
-  Square type output flange
-  Reinforced deep groove ball bearings
-  High ratio variety $i=3$ up to $i=512$
-  Planet carrier in disc design
-  Option: Painted surface – RAL 9005 Jet black

Cyclic torque **14 - 260 Nm**



Radial force **1500 - 4000 N**



Axial force **1950 - 3800 N**



Torsional backlash **11 - 21 arcmin**



Protection class **IP54**



Frame sizes



Economy Line right angle gearbox

WPLPE



The **WPLPE** is the sought-after angle solution from our Economy range: space-saving yet powerful at an attractive price. You attach your drive elements directly to the output shaft, which can also withstand high radial forces thanks to extra-strong deep groove ball bearings.



Economy Line



Spur gear



Bevel gear right angle stage



Round type output flange



Reinforced deep groove ball bearings



Planet carrier in disc design



Option: Painted surface – RAL 9005 Jet black

Cyclic torque **5 - 195 Nm**



Radial force **1300 - 4000 N**



Axial force **1000 - 5900 N**

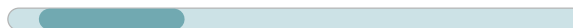

Torsional backlash **11 - 25 arcmin**



Protection class **IP54**

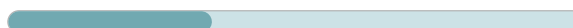

Frame sizes



Economy Line right angle gearbox

WPLHE



Axially space-saving, economical, IP65-compliant and designed for high radial and axial forces at the output: The **WPLHE** combines all the advantages of the successful PLHE, the world's first combination of the Economy and Precision gearboxes, as a right-angle variant.

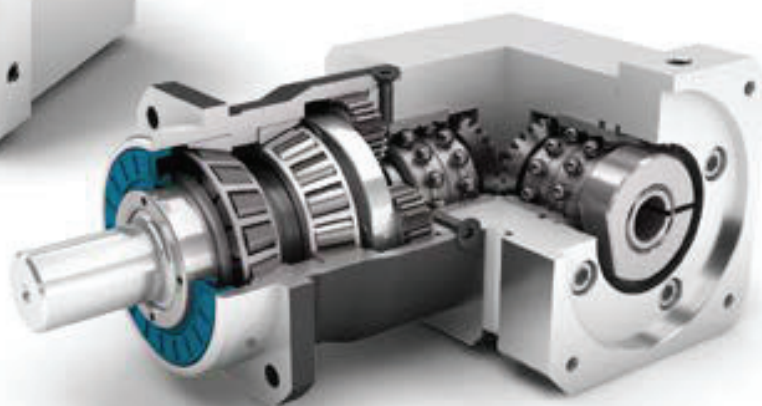

Economy Line



Counterdirectional rotation



Spur gear



Bevel gear right angle stage



Square type output flange



Preloaded tapered roller bearings



Rotary shaft seal



Extra long centering collar



Planet carrier in disc design



Option: Rack and pinion



Option: Painted surface – RAL 9005 Jet black

Cyclic torque **14 - 260 Nm**



Radial force **3200 - 6000 N**



Axial force **4400 - 8000 N**



Torsional backlash **11 - 18 arcmin**



Protection class **IP65**



Frame sizes

60

80

120

Economy Line right angle gearbox

WPLFE



The **WPLFE** is our right-angle planetary gearbox with a compact flange output shaft. You save up to a third of the space. Its standardized flange interface makes it particularly easy to install. The integrated dowel pin drill hole provides additional stability during installation.



Economy Line



Spur gear



Bevel gear right angle stage



Extra large round type output flange



Low-friction deep groove ball bearings



Flange output shaft (ISO 9409-1)



Planet carrier in disc design



Option: Painted surface – RAL 9005 Jet black

Cyclic torque **14 - 260 Nm**



Radial force **900 - 3800 N**



Axial force **1200 - 5200 N**



Torsional backlash **11 - 18 arcmin**



Protection class **IP54**



Frame sizes

64

90

110

Precision Line coaxial gearbox

PSNpro

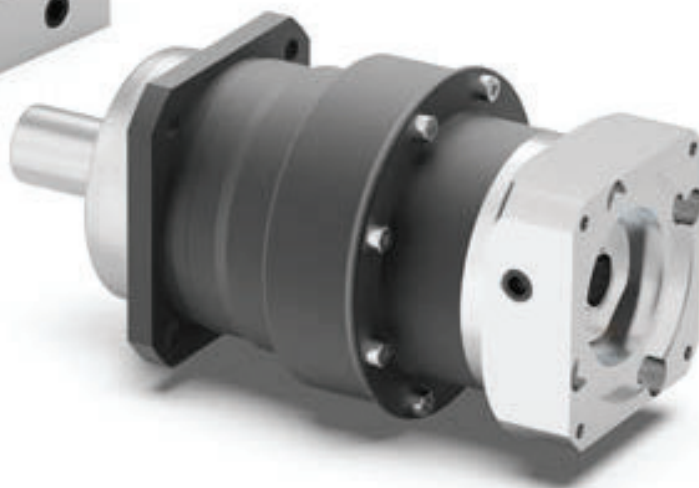

Thanks to its helical gearing, the **PSNpro** enables low-noise operation and maximum synchronisation quality. It is also ideal for high cycle torques. Its preloaded tapered roller bearings and square output flange ensure a high load capacity and allow high output shaft loads, even under extreme conditions.



Precision Line



Helical gear



Square type output flange



Preloaded tapered roller bearings



Rotary shaft seal



Extra long centering collar



Planet carrier in cage design



Option: Reduced backlash



Option: Rack and pinion



Option: Painted surface – RAL 9005 Jet black

Cyclic torque **14 - 1800 Nm**



Radial force **950 - 20000 N**



Axial force **2200 - 17000 N**



Torsional backlash **1 - 8 arcmin**



Protection class **IP65**



Frame sizes

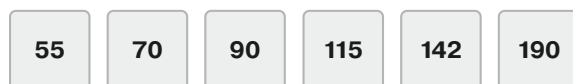

Precision Line coaxial gearbox

PSFNpro

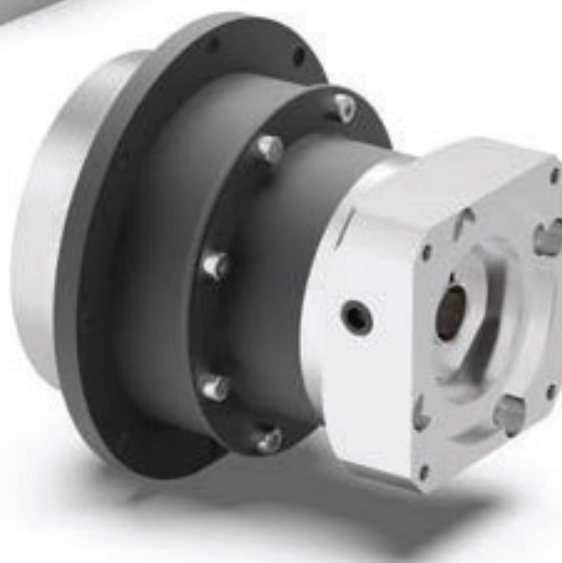

The high-torque and extremely torsion-resistant **PSFNpro** combines maximum precision and power in the smallest of spaces. Its short overall length allows for space-saving integration, and the standardized flange output shaft guarantees secure installation in a wide variety of applications.



Precision Line



Helical gear



Extra large round type output flange



Preloaded angular contact roller bearings



Rotary shaft seal



Flange output shaft (ISO 9409-1)



Planet carrier in cage design



Option: Reduced backlash



Option: Rack and pinion



Option: Painted surface – RAL 9005 Jet black

Cyclic torque **14 - 1800 Nm**



Radial force **1450 - 23000 N**



Axial force **2350 - 12000 N**



Torsional backlash **1 - 8 arcmin**

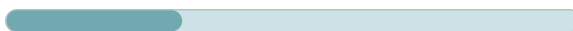

Protection class **IP65**



Frame sizes

55	64	90	110	140	200
----	----	----	-----	-----	-----

Precision Line coaxial gearbox

PSBNpro

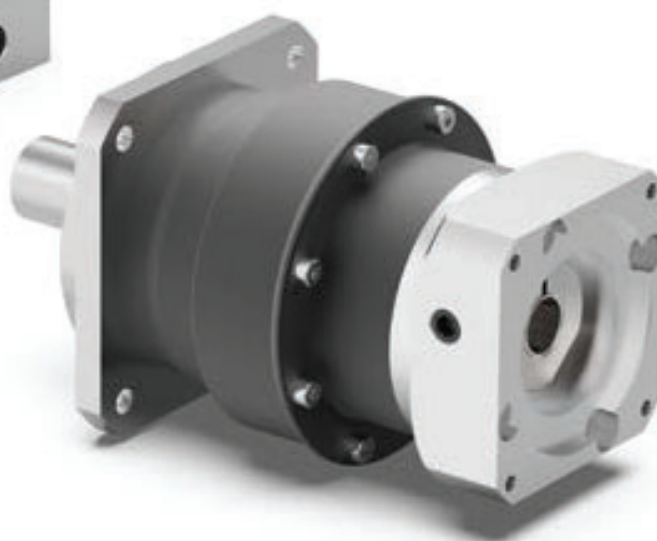

Our **PSBNpro** combines precision planetary gearboxes and efficient bearing technology. Designed for high speeds, it delivers maximum performance thanks to its homogeneous, particularly quiet helical gearing. As a pro variant, it also offers higher torques – reliable, compact, and efficient.



Precision Line



Helical gear



Square type output flange



Reinforced deep groove ball bearings



Rotary shaft seal



Planet carrier in cage design



Option: Reduced backlash



Option: Painted surface – RAL 9005 Jet black

Cyclic torque **14 - 850 Nm**



Radial force **830 - 9500 N**



Axial force **800 - 9600 N**



Torsional backlash **1 - 8 arcmin**

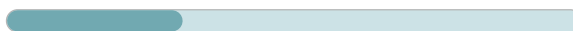

Protection class **IP65**



Frame sizes

55	70	90	115	142
----	----	----	-----	-----

Precision Line coaxial gearbox

PSN

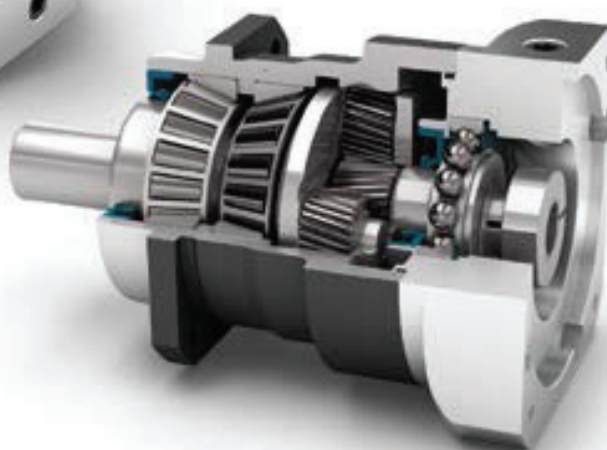

Our **PSN** is pure progress: Its helical gearing ensures low-noise synchronization. With this precision planetary gearbox, vibrations are reduced to a minimum. Precision even under very high loads makes the **PSN** one of the most high-performance gearboxes in the world.



Precision Line



Helical gear



Square type output flange



Preloaded tapered roller bearings



Rotary shaft seal



Extra long centering collar



Planet carrier in cage design



Option: Reduced backlash



Option: Rack and pinion



Option: Painted surface – RAL 9005 Jet black

Cyclic torque **14 - 950 Nm**



Radial force **950 - 20000 N**



Axial force **2200 - 17000 N**



Torsional backlash **1 - 8 arcmin**



Protection class **IP65**



Frame sizes

55	70	90	115	142	190
----	----	----	-----	-----	-----

Precision Line coaxial gearbox

PSFN



Thanks to its standardized flange interface and a planet carrier in a cage design, our **PSFN** is extremely torsionally rigid. The specially developed helical gearing reduces vibrations to a minimum. With its high tilting moment, you can demand a lot from this precision planetary gearbox.

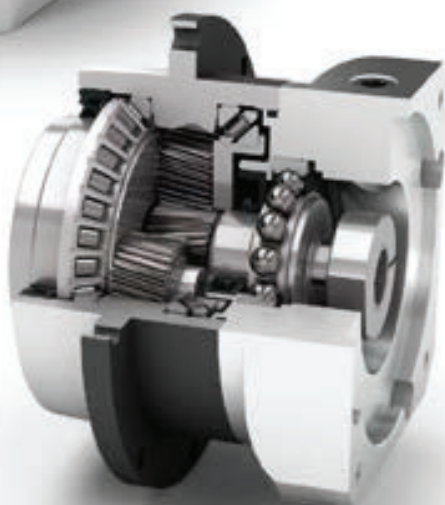

Precision Line



Helical gear



Extra large round type output flange



Preloaded angular contact roller bearings



Rotary shaft seal



Flange output shaft (ISO 9409-1)



Planet carrier in cage design



Option: Reduced backlash



Option: Rack and pinion



Option: Painted surface – RAL 9005 Jet black

Cyclic torque **14 - 950 Nm**



Radial force **1450 - 23000 N**



Axial force **2350 - 12000 N**



Torsional backlash **1 - 8 arcmin**



Protection class **IP65**



Frame sizes

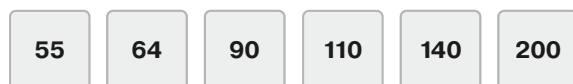

Precision Line coaxial gearbox

PSBN



Our **PSBN** is the ideal combination of a precision planetary gearbox and efficient bearing technology. It was designed specifically to achieve maximum performance at high speed. Thanks to the helical gearing, it operates particularly smoothly - and is quieter than average.



Precision Line



Helical gear



Square type output flange



Reinforced deep groove ball bearings



Rotary shaft seal



Planet carrier in cage design



Option: Reduced backlash



Option: Painted surface – RAL 9005 Jet black

Cyclic torque **14 - 470 Nm**



Radial force **830 - 9500 N**



Axial force **800 - 9600 N**



Torsional backlash **1 - 8 arcmin**

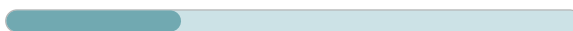

Protection class **IP65**



Frame sizes

55	70	90	115	142
----	----	----	-----	-----

Precision Line coaxial gearbox

PLN



Our precision straight-toothed planetary gearbox is designed for maximum power and torque. The preloaded tapered roller bearings in the **PLN** and the specially matched seal guarantee optimum performance even in applications where dust and water spray are encountered.

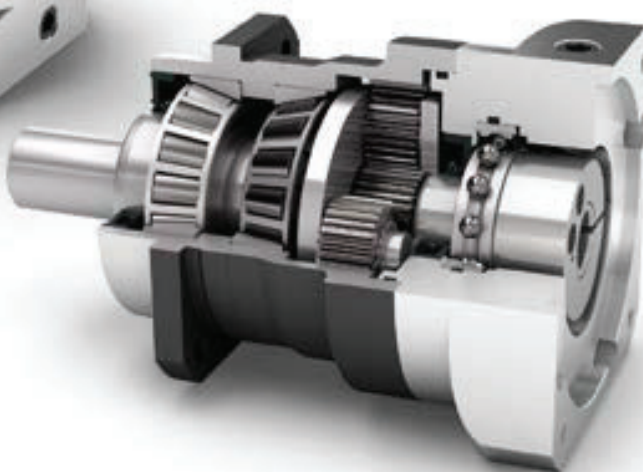

Precision Line



Spur gear



Square type output flange



Preloaded tapered roller bearings



Rotary shaft seal



Extra long centering collar



Planet carrier in cage design



Option: Reduced backlash



Option: Rack and pinion



Option: Painted surface – RAL 9005 Jet black

Cyclic torque **27 - 1800 Nm**

Radial force **3200 - 21000 N**

Axial force **4400 - 21000 N**

Torsional backlash **1 - 5 arcmin**

Protection class **IP65**

Frame sizes

70

90

115

142

190

Precision Line coaxial gearbox

PLFN



Our **PLFN** has a standardized flange interface, which allows easy mounting. The straight-toothed precision planetary gearbox is designed for high performance and torque. Its high tilting moment allows the best performance even with the highest radial and axial forces.



Precision Line



Spur gear



Extra large round type output flange



Preloaded angular contact roller bearings



Rotary shaft seal



Flange output shaft (ISO 9409-1)



Planet carrier in cage design



Option: Reduced backlash



Option: Rack and pinion



Option: Painted surface – RAL 9005 Jet black

Cyclic torque **27 - 1800 Nm**



Radial force **2150 - 33000 N**



Axial force **4300 - 15000 N**



Torsional backlash **1 - 5 arcmin**



Protection class **IP65**



Frame sizes



Precision Line right angle gearbox

WPLN



Due to its hypoid gearing, our **WPLN** achieves optimal synchronization. Because vibrations are reduced to a minimum, it operates smoothly, precisely and quietly. The right-angle precision gearbox is lubricated for life and can be mounted in a variety of ways.



Precision Line



Counterdirectional rotation



Hypoid gear right angle stage



Square type output flange



Preloaded tapered roller bearings



Rotary shaft seal



Extra long centering collar



Option: Reduced backlash (2-stage)



Option: Rack and pinion



Option: Painted surface – RAL 9005 Jet black

Cyclic torque **22 - 800 Nm**



Radial force **3200 - 12500 N**



Axial force **4300 - 15000 N**



Torsional backlash **3 - 5 arcmin**



Protection class **IP65**



Frame sizes



Precision Line right angle gearbox

WPSFN



Our **WPSFN** is particularly easy and quick to integrate thanks to its standardized flange interface and offers high torsional rigidity. With its hypoid gearing, as well as the helical-toothed planetary stage, it achieves optimal synchronization for best surface qualities. The shortest right-angle precision gearbox, in a single-stage design with integrated hollow shaft, offers you new design solutions.

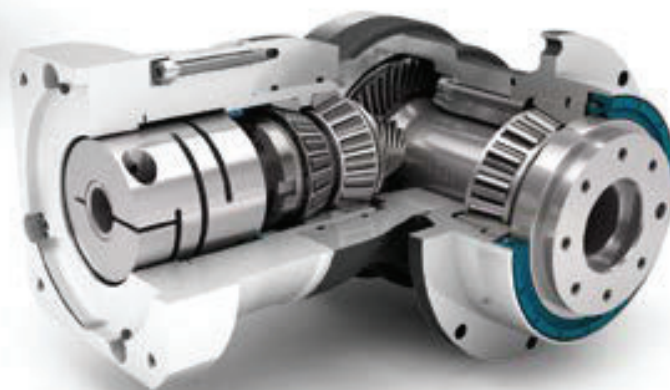

Precision Line



Counterdirectional rotation



Hypoid gear right angle stage



Extra large round type output flange



Preloaded angular contact roller bearings



Rotary shaft seal



Flange output shaft (ISO 9409-1)



Hollow shaft (1-stage)



Option: Reduced backlash (2-stage)



Option: Rack and pinion



Option: Painted surface – RAL 9005 Jet black

Cyclic torque **22 - 620 Nm**



Radial force **2150 - 12000 N**



Axial force **4200 - 9500 N**



Torsional backlash **3 - 5 arcmin**



Protection class **IP65**



Frame sizes



Precision Line right angle gearbox

WGN



Our **WGN** is the right-angle hollow shaft gearbox that operates particularly quietly. At the same time, the hypoid gearing increases the quality of the surface of your work-piece. With a shrink disc, it can be connected directly to the application - this is uncomplicated, safe and opens up new design possibilities.

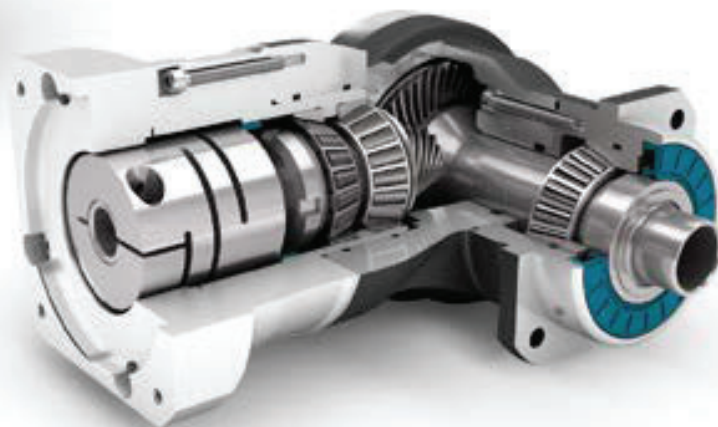

Precision Line



Counterdirectional rotation



Hypoid gear right angle stage



Square type output flange



Preloaded tapered roller bearings



Rotary shaft seal



Extra long centering collar



Hollow shaft for clamping system with shrink disc



Option: Painted surface – RAL 9005 Jet black

Cyclic torque **22 - 320 Nm**



Radial force **2700 - 10000 N**

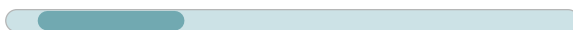

Axial force **4300 - 14500 N**



Torsional backlash **5 arcmin**



Protection class **IP65**



Frame sizes

70	90	115	142
----	----	-----	-----

Application-specific gearbox

HLAE

Hygienic Design
for the Food and
Pharmaceutical
Industries



Our **HLAE** is unique: It is the world's first planetary gearbox in a hygienic design - flexible without a radial bolt, powerful and yet easy and quick to clean. It was developed specifically for applications in sensitive areas such as pharmaceuticals, cosmetics and food.

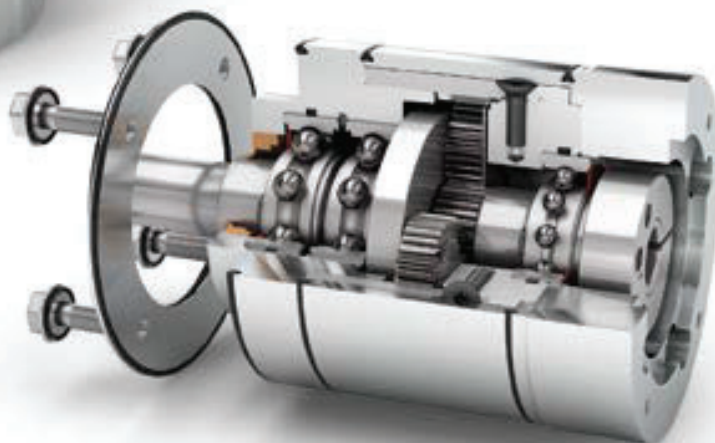

Application-specific gearbox



Hygienic Design



FDA certified materials



Spur gear



Round type output flange



Low-friction deep groove ball bearings



Rotary shaft seal



Extra long centering collar



Planet carrier in disc design

Cyclic torque **15 - 171 Nm**



Radial force **1000 - 5000 N**



Axial force **1200 - 3800 N**

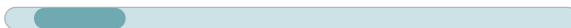

Torsional backlash **7 - 12 arcmin**

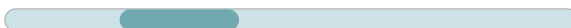

Protection class **IP69K**



Frame sizes

70

90

110









Application-specific gearbox

NDF

For Delta robots

The **NDF** sets the benchmark for delta robot applications. Thanks to the four planetary gears in the reinforced output stage, torsional stiffness and transmissible torque are increased. The Torque Interface of the flange output shaft enables higher load transmission. The special rotary shaft seal and the dynamic drive system ensure maximum performance.



-  Application-specific gearbox
-  Helical gear
-  Torque Interface
-  Preloaded angular contact roller bearings
-  Rotary shaft seal
-  Planet carrier in cage design
-  Four planet gears at the output
-  Option: Painted surface – RAL 9005 Jet black

Cyclic torque **180 - 530 Nm**



Radial force **4000 - 5400 N**



Axial force **4000 - 5400 N**

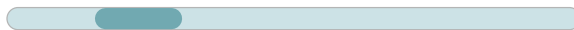

Torsional backlash **1 arcmin**



Protection class **IP65**



Frame sizes

- 90
- 110

Application-specific gearbox

NDFC

For Delta robots

Thanks to its optimized sealing concept, dynamic drive system, and output shaft geometry in accordance with ISO 9409-1, the **NDFC** is the economical choice for delta robot applications. The **NDFC** impresses with its high torsional rigidity and enables the reliable transmission of large forces.



Application-specific gearbox



Helical gear



Extra large round type output flange



Preloaded angular contact roller bearings



Rotary shaft seal



Flange output shaft (ISO 9409-1)



Planet carrier in cage design



Option: Reduced backlash



Option: Painted surface – RAL 9005 Jet black

Cyclic torque **32 - 330 Nm**



Radial force **2150 - 4900 N**



Axial force **2850 - 6450 N**



Torsional backlash **1 - 5 arcmin**

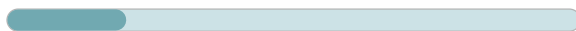

Protection class **IP65**



Frame sizes











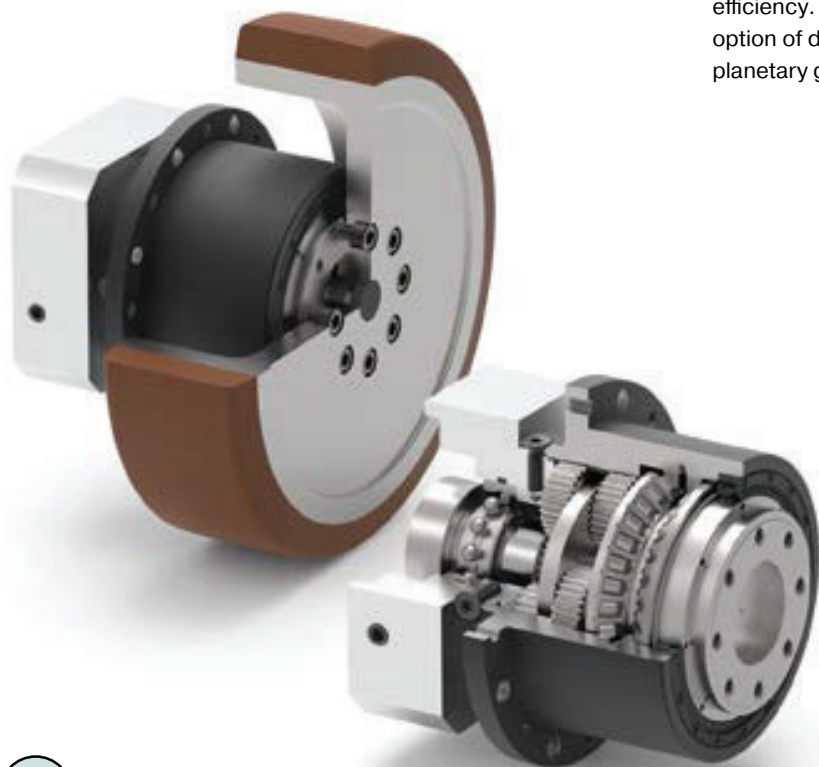

Application-specific gearbox

NGV

For AGVs

Automated guided vehicles have special requirements when it comes to drive technology. These include high radial loads, space-saving design, 24/7 use and energy efficiency. With its special output bearing concept and the option of direct mounting to the vehicle chassis, our **NGV** planetary gearbox precisely meets these requirements.



-  Application-specific gearbox
-  Spur gear
-  Extra large round type output flange
-  Preloaded angular contact roller bearings
-  Rotary shaft seal
-  Extra long centering collar
-  Flange output shaft (ISO 9409-1)
-  Planet carrier in disc design
-  Option: Painted surface – RAL 9005 Jet black

Cyclic torque **18 - 260 Nm**



Radial force **2700 - 7200 N**



Axial force **2850 - 6450 N**

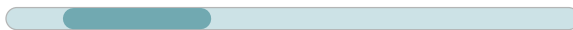

Torsional backlash **9 - 12 arcmin**



Protection class **IP65**



Frame sizes

- 64
- 90
- 110

Custom made gearboxes



Innovative and individual: Our custom made gearboxes.

A custom design, specialized performance data, a modified output shaft, safe for use in the food industry: Do you need an individually adapted gearbox? We can meet your requirements. Quickly and easily by modifying one of our standard planetary gearboxes or with a custom gearbox developed specifically for you. The qualified specialists in our Engineering department design gearbox solutions and systems to meet your requirements: in terms of performance, cost and quality.

With the help of the most modern development and design tools, we design gearboxes suitable for the most diverse applications, from all areas of mechanical and plant engineering, robotics, medical, pharmaceutical and food technology or model making.

Your innovation advantage: We rely on our many years of experience, while at the same time keeping updated on new developments and integrating them into our customer solutions.

Rack and pinion

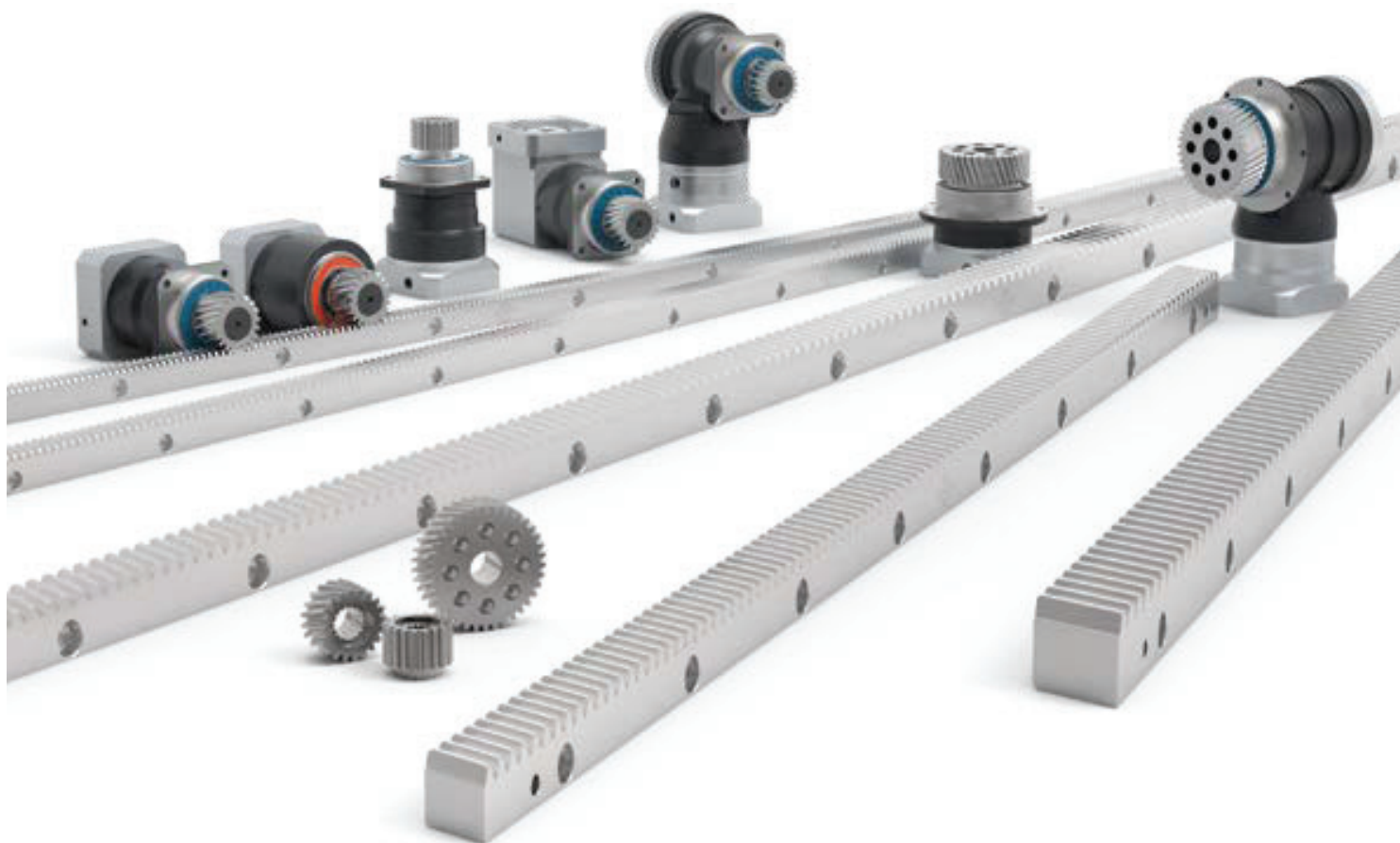

Neugart Rack System

Precision racks for the highest performance requirements

Neugart offers racks of the highest quality with straight or helical gearing. Our standard racks are made of induction-hardened, quenched and tempered steel, cover a module range from 1.5 to 5 mm, and comply with quality level 6.

The racks are heat-treated and ground to optimize their mechanical properties. The standard versions are available in lengths of 1000 mm and 2000 mm. Custom lengths are available upon request.

Module **1,5-5**

Maximum feed force **2-31 kN**

Planetary gearboxes with mounted pinion



Planetary gearboxes with mounted pinion

Numerous combination options from three different pinion types with helical and straight teeth ensure that the ideal solution is available for every application.

The pinions can be paired with different gearbox types, including precision gearboxes for maximum accuracy, Economy gearboxes for maximum durability and efficiency, and right-angle planetary gearbox for special installation situations.

This allows you to benefit from maximum flexibility and technical coordination for a wide range of requirements.

PK1

- The PK1 pinion is mounted directly on the gearbox's toothed output shaft.
- The precise design of the internal spline in accordance with DIN 5480 enables optimum power transmission and ensures a permanently high level of connection reliability, even in demanding applications.



PM1

- The PM1 pinion is specially designed for gearboxes with flange output shafts.
- Thanks to its large circumference, the PM1 pinion enables particularly high feed rates.



PM2

- The PM2 pinion is specially designed for gearboxes with flange output shafts.
- Thanks to its low number of teeth, the PM2 pinion enables particularly high feed forces.



Performance classes

Our program at a glance.

In this overview you will find a direct comparison of the key features of our products.

Economy		Cyclic torque	Backlash	Bearing load	Protection class	Running noise	Input speeds	Torsional stiffness	Wide range of ratios
PLE		Standard	Standard	Standard	Standard	Standard	Excellent	Standard	Excellent
PLQE		Standard	Standard	Standard	Standard	Standard	Excellent	Standard	Excellent
PLPE		Standard	Standard	Standard	Standard	Standard	Excellent	Standard	Standard
PLHE		Standard	Standard	Standard	Standard	Standard	Standard	Standard	Standard
PLFE		Standard	Standard	Standard	Standard	Standard	Excellent	Standard	Standard
PFHE		Standard	Standard	Standard	Standard	Standard	Standard	Standard	Standard
WPLE		Standard	Standard	Standard	Standard	Standard	Excellent	Standard	Excellent
WPLQE		Standard	Standard	Standard	Standard	Standard	Excellent	Standard	Excellent
WPLPE		Standard	Standard	Standard	Standard	Standard	Excellent	Standard	Standard
WPLHE		Standard	Standard	Standard	Standard	Standard	Standard	Standard	Standard
WPLFE		Standard	Standard	Standard	Standard	Standard	Excellent	Standard	Standard

— Standard ——— Excellent

Performance classes

Precision Line		Cyclic torque	Backlash	Bearing load	Protection class	Running noise	Input speeds	Torsional stiffness	Wide range of ratios
PSNpro		-----	-----	-----	-----	-----	-----	-----	-----
PSFNpro		-----	-----	-----	-----	-----	-----	-----	-----
PSBNpro		-----	-----	-----	-----	-----	-----	-----	-----
PSN		-----	-----	-----	-----	-----	-----	-----	-----
PSFN		-----	-----	-----	-----	-----	-----	-----	-----
PSBN		-----	-----	-----	-----	-----	-----	-----	-----
PLN		-----	-----	-----	-----	-----	-----	-----	-----
PLFN		-----	-----	-----	-----	-----	-----	-----	-----
WPLN		-----	-----	-----	-----	-----	-----	-----	-----
WPSFN		-----	-----	-----	-----	-----	-----	-----	-----
WGN		-----	-----	-----	-----	-----	-----	-----	-----

Application specific gearboxes		Cyclic torque	Backlash	Bearing load	Protection class	Running noise	Input speeds	Torsional stiffness	Wide range of ratios
HAE		-----	-----	-----	-----	-----	-----	-----	-----
NGV		-----	-----	-----	-----	-----	-----	-----	-----
NDF		-----	-----	-----	-----	-----	-----	-----	-----
NDFC		-----	-----	-----	-----	-----	-----	-----	-----

— Standard ----- Excellent



Do you have any questions or need further information?

We are happy to advise you on all topics relating to drive technology.

You can find your personal contact at: www.neugart.com

Neugart GmbH

Keltenstraße 16
77971 Kippenheim
Germany

Phone: +49 7825 847 -0

Email: sales@neugart.com

Web: www.neugart.com

Neugart USA Corp.

14325 South Lakes Drive
Charlotte, NC 28273
USA

Phone: +1 980 299-9800

Email: sales@neugartusa.com

Web: www.neugart.com/en-us

Neugart Planetary Gearboxes (Shenyang) Co., Ltd.

No.152-1, 22nd road
E&T Development Zone Shenyang, PC 110143
PR China

Phone: +86 24 2537 -4959

Email: sales@neugart.net.cn

Web: www.neugart.net.cn

100324516 Precision gearbox brochure 11.2025 - Subject to modifications