

# W22

Three-Phase Electric Motor

Technical Catalogue  
European Market

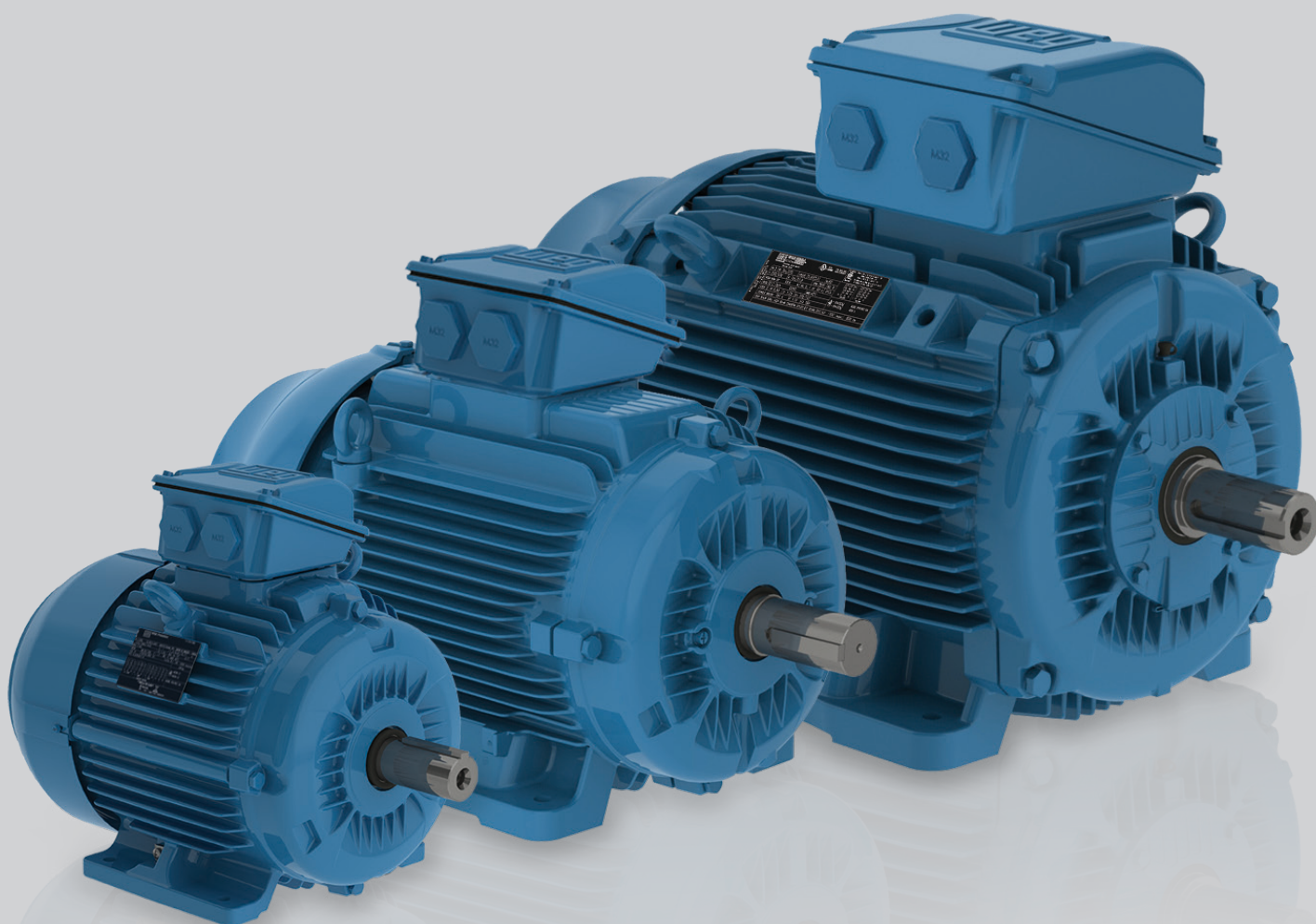

Motors | Automation | Energy | Transmission & Distribution | Coatings



## W22 Line

The increasing demand for electrical energy to sustain global development requires consistent heavy investments in power supply generation. However, in addition to complex medium and long term planning, these investments rely on natural resources, which are becoming depleted due to constant pressures upon the environment. The best strategy, therefore, to maintain energy supply in the short term is to avoid wastage and increase energy efficiency. Electric motors play a major role in this strategy, since around 40% of global energy demand is estimated to be related to electric motor applications. Consequently, any initiatives to increase energy efficiency, by using high efficiency electric motors and frequency inverters, are to be welcomed, as they can make a real contribution to reductions in global energy demand.

At the same time as efficiency initiatives make an impact in traditional market sectors, the application of new technologies in emerging sectors is resulting in profound changes in the way that electric motors are applied and controlled. By integrating these changes together with the demands for increased energy efficiency, WEG has taken up the challenge and produced a new design of high efficiency motor, one that exceeds the performance of the previous WEG's W21 motor line, which is recognised worldwide for its quality, reliability and efficiency.

Using the latest generation of computerised tools, such as structural analysis software (finite element analysis) and computer fluid dynamics, as well as electrical design optimization software, an innovative - next generation - product has been developed: the W22 motor.

Several key objectives have been achieved in the design of the W22 motor:

- Reduction of noise and vibration levels;
- Increased energy efficiency and reduced thermal footprint;
- Easy maintenance;
- Compatibility with present & future generations of frequency inverters;
- Flexible and modular design.



Frame 63 to 132



Frame 160 to 200



Frame 225 to 355

## Sustainability and Carbon Emission Reduction Through Super Premium Efficiency Motors

The Super Premium Efficiency (IE4) level established in IEC 60034-30-1: 2014 is considered the highest efficiency class which a squirrel cage induction motor can achieve whilst remaining economically viable. It is also the optimum solution to increase the efficiency of an existing application through direct replacement. So, why have Super Premium Efficiency motors not become the Industry standard?

It may be argued that super premium efficiency motors are also super premium in price when comparing against standard efficiency (IE1), high efficiency (IE2) and premium efficiency (IE3) motors.

Whilst this is not strictly untrue, it should be appreciated when considering their lifetime that the cost of acquisition of an induction motor typically represents only 2% of the total cost of ownership. In contrast, the associated energy savings provided by Super Premium

and Premium efficiency motors far outweigh this additional investment in purchase price.

The reduction in CO<sub>2</sub> emissions is one of the direct consequences, and therefore benefits, of increasing efficiency in industry. Using IE4 rated motors today will show that a company is serious about saving energy, reducing carbon and saving money.

Visit our website at [www.weg.net](http://www.weg.net) to check the potential energy savings, CO<sub>2</sub> emissions reduction and return on investment with W22 Premium and Super Premium motors.

The W22 Super Premium Efficiency line from WEG is the most complete range of IE4 motors available to Industry today, designed to offer not only a significant reduction in energy consumption, but improved noise and vibration levels, higher reliability, easier maintenance and lower overall total cost of ownership.

...we call it **WEGnology**

## Minimum Energy Performance Standards - Europe

Increasingly, the World seeks a path of sustainability and new ways to reduce energy consumption.

A significant percentage of the electrical energy utilized in facilities around the World is consumed by electric motors. Consequently, Governments around the World are implementing Energy Efficiency Programs in order to enforce the use of high efficiency motors.

Up until 2009, Europe did not have any specific regulations relating to the energy efficiency levels of electric motors. There existed only a voluntary agreement between Manufacturers from 1998 that determined the efficiency bands EFF1, EFF2 and EFF3.

However, in July 2009 Commission Regulation 640/2009 (implementing EuP Directive 2005/32/EC of July 2005) was adopted, which determined the ecodesign requirements relating to the scope, implementation dates and efficiency levels for electric motors and their use with variable speed drives.

Also referred to as EU MEPS (European Minimum Energy Performance Standards), the efficiency levels for electric motors are determined in two IEC standards:

IEC/EN 60034-30-1, which details the efficiency classes in the form of 'IE' codes, and IEC/EN 60034-2-1 which defines the methods to be used to measure the efficiency.

The EU Regulation is mandatory within the European Economic Area, EEA (EU countries plus Norway, Iceland and Liechtenstein), from 16th of June 2011.

EU MEPS does not apply outside Europe.

Manufacturers can continue to supply IE1 non-CE marked motors to customers located in Europe for further shipment to non-European markets, but these must of course respect any applicable energy efficiency legislation for the destination country of use.

A new version of the EuP Directive (2009/125/EC) became effective on 21st October 2009 to expand the ecodesign requirements for Energy Related Products, whilst January 2014 saw the adoption of the Commission Regulation 4/2014 (amending the scope of 640/2009) which came into force with effect and is going to the end in 30th June 2021.

Now, updating the Regulation (EC) 640/2009, a new European Regulation (EU) 1781/2019 laying down eco-design requirements for electric motors and variable speed drives. The new requirements were defined in the new directive in two future steps that includes 1-phase motors and Variable Speed Drives.

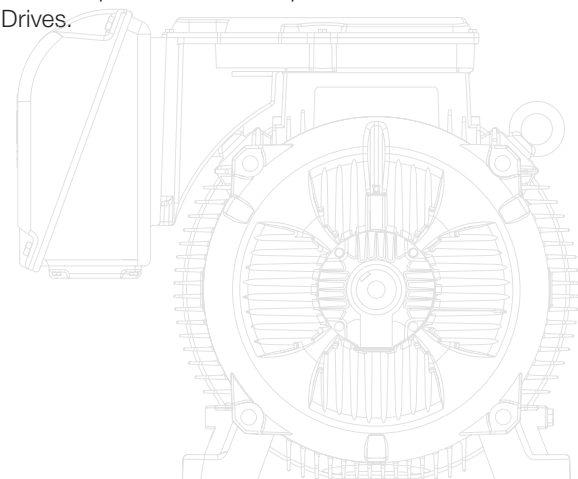

## Scope

The scope of the EuP motor regulation (which is more limited than that of the IEC 60034-30-1 standard), covers single speed, three-phase squirrel-cage induction motors for 50 Hz or 50/60 Hz operation which:

- Have 2, 4, or 6 poles
- Have a rated voltage ( $U_N$ ) up to 1000 V
- Have a rated output ( $P_N$ ) between 0,75 kW and 375 kW
- Are rated for continuous duty operation (S1)
- Are intended for use at altitudes up to 4,000 metres above sea level or at ambient air temperatures between -30 °C and +60 °C.

However, the Regulation does not apply to:

- a) Motors designed to operate wholly immersed in liquid.
- b) Motors completely integrated into a product where its energy efficiency cannot be measured independently.
- c) Motors designed to operate exclusively:
  - at altitudes greater than 4,000 metres above sea level
  - in ambient air temperatures exceeding 60 °C
  - in maximum operating temperature above 400 °C
  - where ambient air temperatures are below -30 °C (or 0 °C for water cooled motors)
  - where water coolant temperatures are below 0 °C or above 32 °C at the inlet to the product
  - in potentially explosive atmospheres defined in the Directive 94/9/EC

d) Brake motors

## Effective Dates

The implementation dates of the Regulation (EU) 1781/2019 are as follows:

- Step 1 - From July 1st, 2021  
The regulation will cover 3-phase single speed motors 50 Hz, 60 Hz, 50/60 Hz, brake motors with external brake, motors 'Ex tb', 'Ex tc', 'Ex ec', 'Ex dc\*', 'Ex db' and 'Ex db eb' rated for duty class: S1, S3 ≥ 80%, S6 ≥ 80% and also TEAO motors. Motors able for use direct online, even if equipped with VSD must meet the same rules for motors without VSD.
- Step 2 - From July 1st, 2023  
IE4 for 3-phase will become mandatory for 2-6 poles single speed motors between 75-200 kW. The coverage is also extended to 'Ex eb' motors and 1-phase motors according minimum IE2.

## Equipment Marking

Those IE2 motors which are required to be operate with a variable speed drive, must bear a sticker/label to ensure that the End User is made aware of the compulsory need to equip the motor with a VSD.

IE2 motors from WEG (0,75-375 kW) per Stage 3 of the Regulation are provided with a sticker as follows:



Output	IE1 - Standard Efficiency				IE2 - High Efficiency				IE3 - Premium Efficiency				IE4 - Super Premium Efficiency			
	Poles															
kW	2	4	6	8	2	4	6	8	2	4	6	8	2	4	6	8
0,12	45,0	50,0	38,3	31,0	53,6	59,1	50,6	39,8	60,8	64,8	57,7	50,7	66,5	69,8	64,9	62,3
0,18	52,8	57,0	45,5	38,0	60,4	64,7	56,6	45,9	65,9	69,9	63,9	58,7	70,8	74,7	70,1	67,2
0,20	54,6	58,5	47,6	39,7	61,9	65,9	58,8	47,4	67,2	71,1	65,4	60,6	71,9	75,5	71,4	68,4
0,25	58,2	61,5	52,1	43,4	64,8	68,5	61,6	50,6	69,7	73,5	68,6	64,1	74,3	77,9	74,1	70,8
0,37	63,9	66,0	59,7	49,7	69,5	72,7	67,6	56,1	73,8	77,3	73,5	69,3	78,1	81,1	78,0	74,3
0,40	64,9	66,8	61,1	50,9	70,4	73,5	68,8	57,2	74,6	78,0	74,4	70,1	78,9	81,7	78,7	74,9
0,55	69,0	70,0	65,8	56,1	74,1	77,1	73,1	61,7	77,8	80,8	77,2	73,0	81,5	83,9	80,9	77,0
0,75	72,1	72,1	70,0	61,2	77,4	79,6	75,9	66,2	80,7	82,5	78,9	75,0	83,5	85,7	82,7	78,4
1,1	75,0	75,0	72,9	66,5	79,6	81,4	78,1	70,8	82,7	84,1	81,0	77,7	85,2	87,2	84,5	80,8
1,5	77,2	77,2	75,2	70,2	81,3	82,8	79,8	74,1	84,2	85,3	82,5	79,7	86,5	88,2	85,9	82,6
2,2	79,7	79,7	77,7	74,2	83,2	84,3	81,8	77,6	85,9	86,7	84,3	81,9	88,0	89,5	87,4	84,5
3	81,5	81,5	79,7	77,0	84,6	85,5	83,3	80,0	87,1	87,7	85,6	83,5	89,1	90,4	88,6	85,9
4	83,1	83,1	81,4	79,2	85,8	86,6	84,6	81,9	88,1	88,6	86,8	84,8	90,0	91,1	89,5	87,1
5,5	84,7	84,7	83,1	81,4	87,0	87,7	86,0	83,8	89,2	89,6	88,0	86,2	90,9	91,9	90,5	88,3
7,5	86,0	86,0	84,7	83,1	88,1	88,7	87,2	85,3	90,1	90,4	89,1	87,3	91,7	92,6	91,3	89,3
11	87,6	87,6	86,4	85,0	89,4	89,8	88,7	86,9	91,2	91,4	90,3	88,6	92,6	93,3	92,3	90,4
15	88,7	88,7	87,7	86,2	90,3	90,6	89,7	88,0	91,9	92,1	91,2	89,6	93,3	93,9	92,9	91,2
18,5	89,3	89,3	88,6	86,9	90,9	91,2	90,4	88,6	92,4	92,6	91,7	90,1	93,7	94,2	93,4	91,7
22	89,9	89,9	89,2	87,4	91,3	91,6	90,9	89,1	92,7	93,0	92,2	90,6	94,0	94,5	93,7	92,1
30	90,7	90,7	90,2	88,3	92,0	92,3	91,7	89,8	93,3	93,6	92,9	91,3	94,5	94,9	94,2	92,7
37	91,2	91,2	90,8	88,8	92,5	92,7	92,2	90,3	93,7	93,9	93,3	91,8	94,8	95,2	94,5	93,1
45	91,7	91,7	91,4	89,2	92,9	93,1	92,7	90,7	94,0	94,2	93,7	92,2	95,0	95,4	94,8	93,4
55	92,1	92,1	91,9	89,7	93,2	93,5	93,1	91,0	94,3	94,6	94,1	92,5	95,3	95,7	95,1	93,7
75	92,7	92,7	92,6	90,7	93,8	94,0	93,7	91,6	94,7	95,0	94,6	93,1	95,6	96,0	95,4	94,2
90	93,0	93,0	92,9	91,1	94,1	94,2	94,0	91,9	95,0	95,2	94,9	93,4	95,8	96,1	95,6	94,4
110	93,3	93,3	93,3	91,5	94,3	94,5	94,3	92,3	95,2	95,4	95,1	93,7	96,0	96,3	95,8	94,7
132	93,5	93,5	93,5	91,9	94,6	94,7	94,6	92,6	95,4	95,6	95,4	94,0	96,2	96,4	96,0	94,9
160	93,8	93,8	93,8	92,5	94,8	94,9	94,8	93,0	95,6	95,8	95,6	94,3	96,3	96,6	96,2	95,1
200	94,0	94,0	94,0	92,5	95,0	95,1	95,0	93,5	95,8	96,0	95,8	94,6	96,5	96,7	96,3	95,4
250	94,0	94,0	94,0	92,5	95,0	95,1	95,0	93,5	95,8	96,0	95,8	94,6	96,5	96,7	96,5	95,4
315 up to 1000	94,0	94,0	94,0	92,5	95,0	95,1	95,0	93,5	95,8	96,0	95,8	94,6	96,5	96,7	96,6	95,4

Table 1 - Minimum efficiency levels (according to IEC 60034-30-1:2014).

WEG can support the movement towards these high efficiency levels by offering a comprehensive range of products meeting the IE1, IE2, IE3 and even IE4 criteria detailed above. Additionally our variable speed drives are perfectly matched to our motors, affording you the most reliable package of motor / drive products in industry. To learn more about WEG, our products and the new Global Directives, go to [www.weg.net](http://www.weg.net).

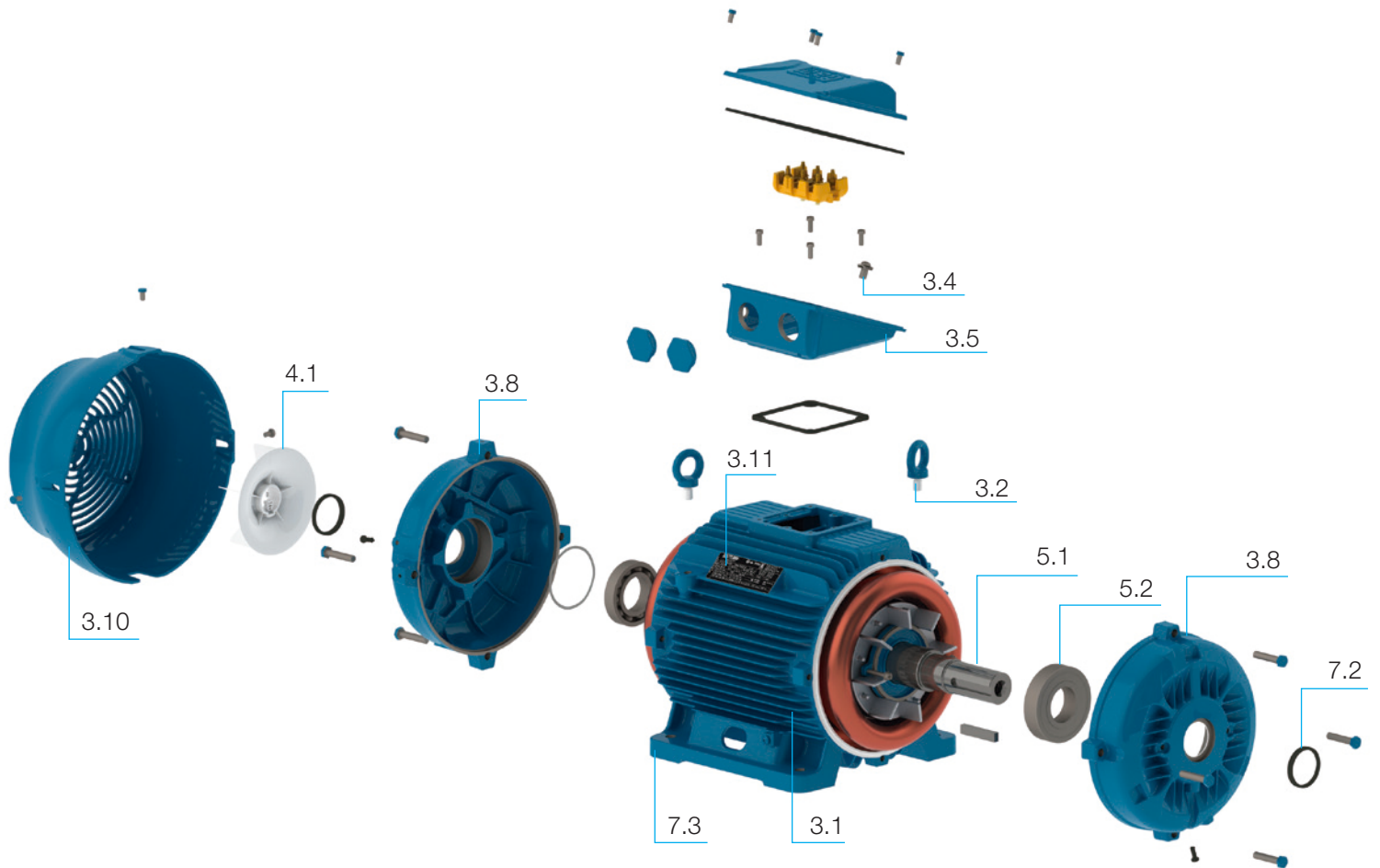

# Visual Index

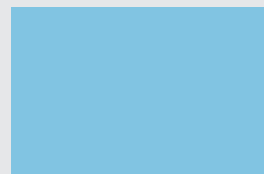
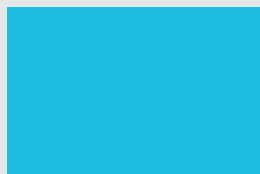
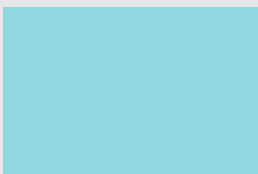

# Table of Contents

1. Versions Available .....	8
2. Standards.....	9
3. Construction Details .....	9
3.1 Frame.....	9
3.2 Eyebolts .....	10
3.3 Points for Vibration Monitoring.....	10
3.4 Earth Terminals .....	10
3.5 Terminal Box .....	10
3.6 Power Supply Connection Leads.....	11
3.7 Accessory Connection Leads.....	11
3.8 Endshields.....	12
3.9 Drains.....	12
3.10 Fan Cover .....	12
3.11 Nameplate.....	12
4. Cooling System and Noise Level / Vibration Level / Impact Resistance .....	13
4.1 Cooling System.....	13
4.2 Noise Level.....	13
4.3 Vibration Level.....	14
4.4 Impact Resistance .....	14
5. Shaft / Bearings.....	14
5.1 Shaft.....	14
5.2 Bearings .....	14
6. Mounting Forms .....	18
7. Degree of Protection / Sealing System / Painting.....	18
7.1 Degree of Protection .....	18
7.2 Sealing System .....	19
7.3 Painting.....	19
8. Voltage / Frequency.....	19
9. Overload Capacity .....	20
10. Ambient and Altitude .....	20
11. Insulation & Temperature Rise .....	20
11.1 Space Heaters.....	20
12. Motor Protections .....	21
12.1 Protection Based on Operating Temperature .....	21
12.2 Protection Based on Operating Current .....	21
13. Variable Speed Drive Application .....	21
13.1 Considerations Regarding Voltage Spikes and the Insulation System.....	21
13.2 Influence of the VSD on the Motor Temperature .....	22
13.3 Considerations Regarding Bearing Currents .....	23
13.4 Forced Ventilation .....	23
13.5 Encoders.....	23
14. Tolerances for Electrical Data .....	23
15. Construction Features .....	24
16. Optional Features.....	26
17. Electrical Data .....	32
18. Mechanical Data.....	44
19. Terminal Box Drawings .....	50
20. Drip Cover Data.....	51
21. External Motor Dimensions with Forced Ventilation .....	51
22. Silencer .....	52
23. Leveling Screws and Dowel Pins.....	52
24. Packaging.....	53
24. Spare Parts.....	54

# 1. Versions Available

Meeting the legislative requirements of the European Market, W22 motors are available in three versions in accordance with IEC 60034-30-1:2014: High Efficiency (IE2), Premium Efficiency (IE3) and Super Premium Efficiency (IE4). Figure 1 shows the efficiency levels established by IEC 60034-30-1:2014 for induction motors.

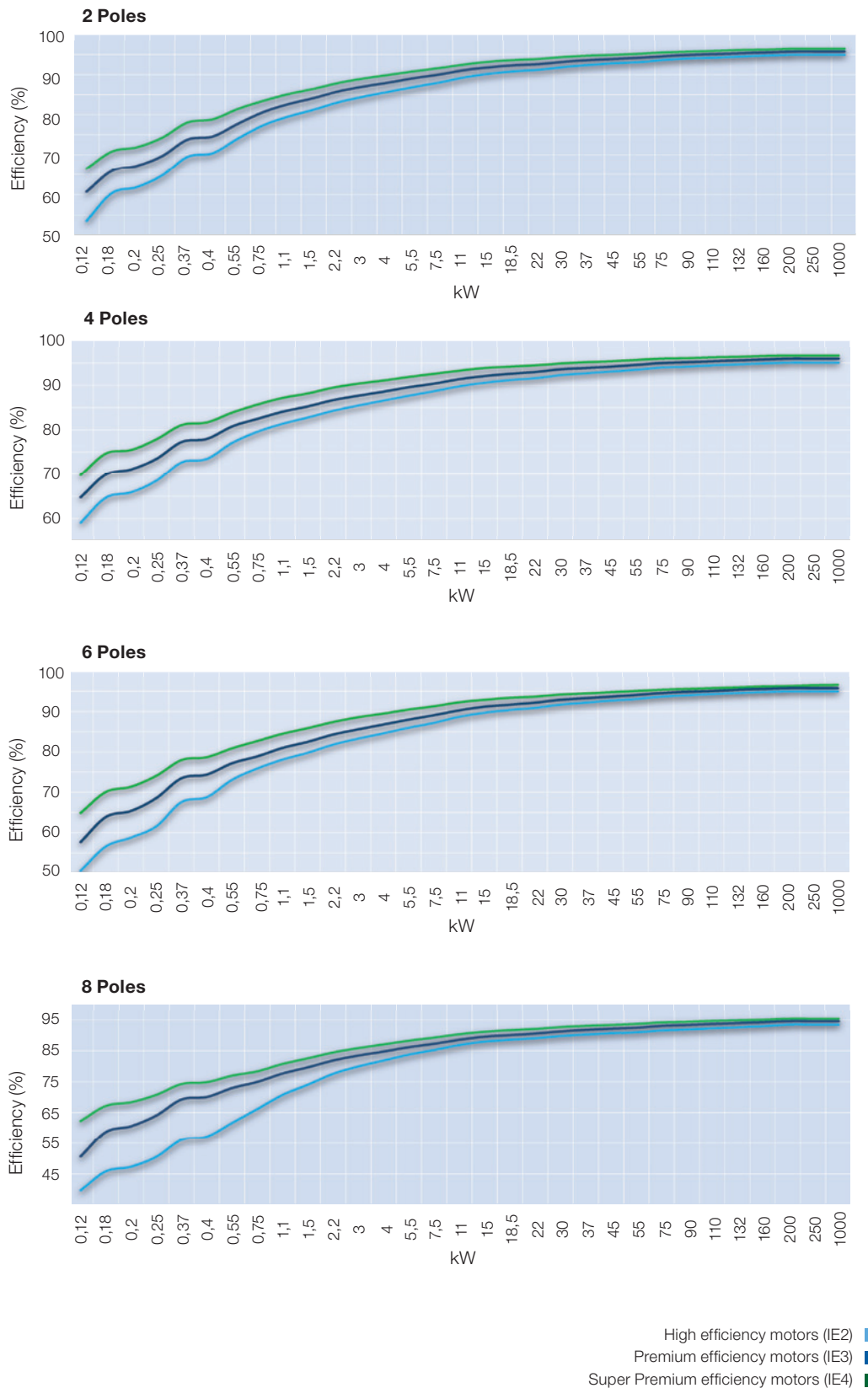

Figure 1 - Efficiency levels according to IEC 60034-30-1:2014



Efficiency values for W22 motors are prepared in accordance with the test standard IEC 60034-2-1:2014, with stray load losses determined directly by the summation of losses.

The output versus frame ratio for all W22 motors follows the EN 50347 standard, thus allowing direct replacement of existing lower efficiency motors with High (IE2), Premium (IE3) or Super Premium (IE4) machines.

A further characteristic of the W22 electrical design is that it was conceived in such way that its efficiency remains practically constant in the 75% to 100% load range. Therefore, even when the motor is not running at full load its efficiency is not affected (see figure 2).

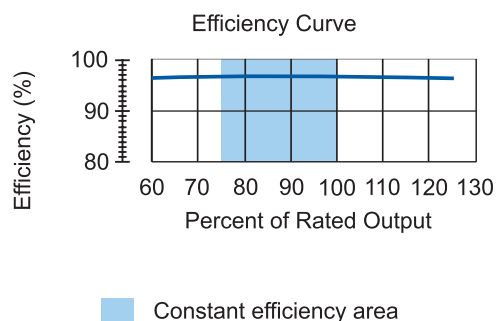

Figure 2 - Typical efficiency curve of W22 line

## 2. Standards

W22 motors meet the requirements and regulations of the latest versions of the following International Standards:

- IEC 60034-1 Rotating electrical machines - Part 1: Rating and performance.
- IEC 60034-2-1 Rotating electrical machines - Part 2-1: Standard methods for determining losses and efficiency from tests (excluding machines for traction vehicles).
- IEC 60034-5 Rotating electrical machines - Part 5: Degrees of protection provided by the integral design of rotating electrical machines (IP code) - classification.
- IEC 60034-6 Rotating electrical machines - Part 6: Methods of cooling (IC code).
- IEC 60034-7 Rotating electrical machines - Part 7: Classification of types of enclosures and mounting arrangements (IM code).
- IEC 60034-8 Rotating electrical machines - Part 8: Terminal markings and direction of rotation.
- IEC 60034-9 Rotating electrical machines - Part 9: Noise limits.
- IEC 60034-11-1 Rotating electrical machines - Part 11-1: Thermal protection.
- IEC 60034-12 Rotating electrical machines - Part 12: Starting performance of single-speed three-phase cage induction motors.

- IEC 60034-14 Rotating electrical machines - Part 14: Mechanical vibration of certain machines - Limits of vibration.
- IEC 60034-30-1 Rotating electrical machines - Part 30: Efficiency classes for single-speed three-phase cage induction motors.
- IEC 60072-1 Dimensions and output series for rotating electrical machines - Part 1: Frame numbers 56 to 400 and flange numbers 55 to 1080.
- EN 50347 General purpose three-phase induction motors having standard dimensions and outputs - frame numbers 56 to 315 and flange numbers 65 to 740.

## 3. Construction Details

The information included in this technical catalogue refers to the standard construction features and most common variations for W22 Low Voltage General Purpose Motors in frame sizes from IEC 63 to 355A/B. W22 motors for special and/or customized applications are available on request. For more information, please, contact your WEG office or distributor.

### 3.1 Frame

The W22 frame (figure 3) is manufactured in FC-200 (EN GJL 200) cast iron providing high levels of mechanical strength to cater for the most demanding applications. The cooling fins are designed to minimize the accumulation of liquids and dust on the motor.



Figure 3 - W22 Frame

The motor feet are completely solid for optimal mechanical strength (figure 4), allowing easier alignment and installation.

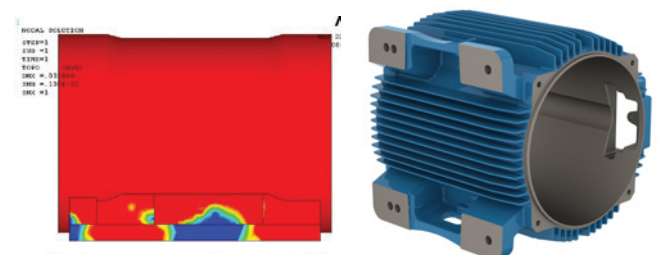

Figure 4 - Solid feet

### 3.2 Eyebolts

Eyebolts are provided as standard from frame size 100L. The positions of the eyebolts are shown in the table 3:

Number of eyebolts	Description
1	Frames 100L to 200L Motors with feet and with side mounted terminal box
2	Frames 100L to 200L Motors with feet and with top mounted terminal box
2	Frames 100L to 200L - Motors without feet and with C or FF flange
2	Frames 225S/M to 355A/B - Motors with feet and side or top mounted terminal box. These motors have four threaded holes in the upper part of the frame for fastening of the eyebolts (figure 5)
2	Frames 225S/M to 355A/B - Motors without feet and with C or FF flange. These motors have four threaded holes in the upper part of the frame for fastening of the eyebolts and two more threaded holes in the bottom part

Table 3 - Eyebolts

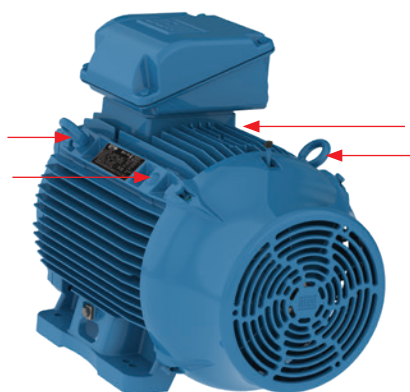

Figure 5 - Motor with four threaded holes for fastening of the eyebolts

### 3.3 Points for Vibration Monitoring

To allow easy maintenance, specifically vibration testing, the 160 to 355 frames are designed with flat areas on both ends for better placement of accelerometers (figure 6). These flat areas are provided in both vertical and horizontal planes. As an option M8 threads for SPM accelerometers can be supplied.

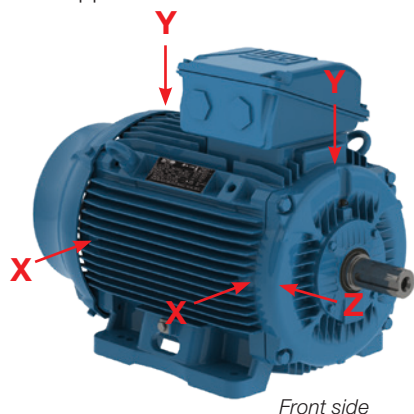

Figure 6 - Flat surfaces for vibration monitoring on the top, front and side.

### 3.4 Earth Terminals

All frames from 63 to 355A/B are provided with an earth terminal located inside the terminal box (see figure 7). Motors in frames 225S/M to 355A/B are also fitted with an earth terminal on the frame. It is located on the same side of the main terminal box cable entry (see figure 7) and is responsible to equalize electrical potential and provide greater safety for operators. Capable of terminating cables from 25 mm<sup>2</sup> to 185 mm<sup>2</sup>.

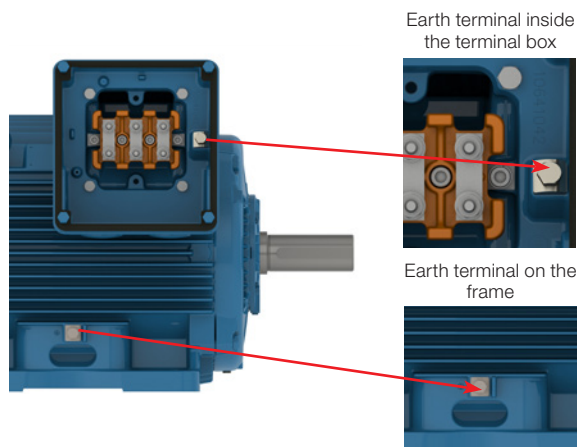

Figure 7 - Earth terminal inside the terminal box and on the frame

Optionally, an external earth terminal can be provided for motors in frame sizes 63 to 200, and, for frame sizes 80 to 355A/B a second external earth terminal as indicated in figure 8.

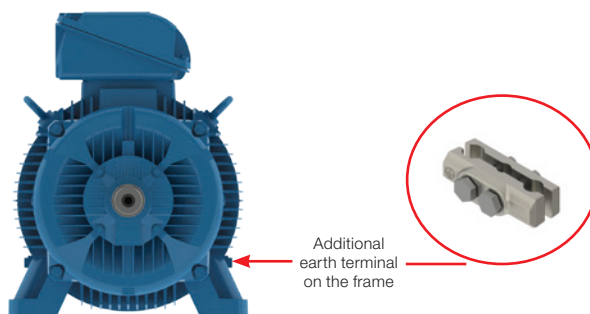

Figure 8 - Additional earth terminal position on the frame.

### 3.5 Terminal Box

The terminal box of W22 motors is produced in FC-200 (EN GJL 200) cast iron, which is the same material used for the frame and endshields. It is diagonally split for easier handling of leads and connections.

For the frame size range 63 to 200 the terminal box position is centralized on the motor frame and can be supplied in two configurations - top (standard) or left / right side (optional). A motor with a side mounted terminal box (B3R or B3L) can have the terminal box position located on the opposite side through modification.

For frame sizes 225S/M to 355A/B the terminal box is positioned towards the drive end of the motor and on top as standard.

This arrangement allows improvement of the airflow over the cooling fins, thus reducing motor operating temperatures.

Terminal box position on either the left or right hand side of the motor is possible through the use of an adaptor (see figure 9).

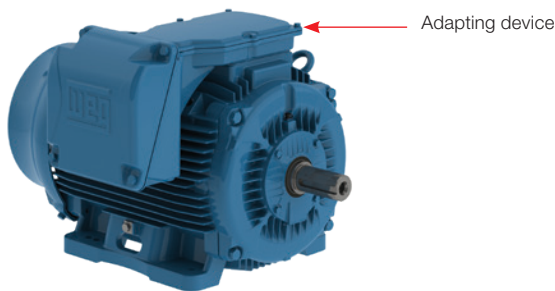

Figure 9 - Terminal box mounted on the left side viewing from drive end shaft

When supplied from the factory with a side mounted terminal box arrangement, this can be positioned on the opposite side simply by rotating the adaptor.

Similarly, by removing the adaptor and adjusting the length of the motor leads, the terminal box can be positioned on top of the motor.

The flexibility of terminal box positions on the W22 motor offered by the adaptor can be seen in figure 10.

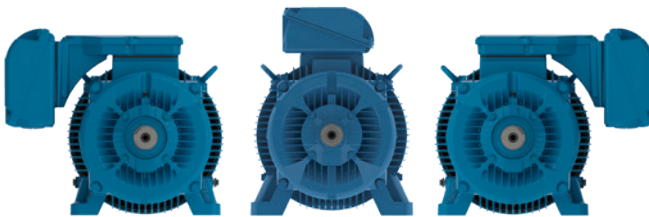

Figure 10 - Terminal box mounted on both sides and on top (versatility)

Conversely, factory supplied motors with the terminal box position on top can be modified to side mounting by fitting the adaptor and extending the motor leads.

**Note: For all terminal box position modifications please contact WEG or your local WEG service centre.**

For all frames, the terminal box can be rotated in 90° increments. Motors in IEC frame sizes 315L, 355M/L and 355A/B are supplied as standard with removable cast iron cable gland plates. As an option, the gland plates can be supplied undrilled.

Motors are supplied with plastic threaded plugs in the cable entries for protection against ingress of solid objects during transport.

In order to guarantee the degree of protection, cable glands must comply with at least the same degree of protection as that indicated on the motor nameplate. Lack of compliance with such detail can invalidate the motor warranty. If required, please contact the WEG Service Area for further advice.

### 3.6 Power Supply Connection Leads

Motor power supply leads are marked in accordance with IEC 60034-8 and are connected to a terminal block made from a polyester based resin BMC (Bulk Moulding Compound), duly reinforced with fibre glass (see figure 11).



Figure 11 - BMC terminal block

Motors in frame size 355A/B are provided with a staggered terminal block arrangement, as indicated in figure 12.



Figure 12 - 355A/B staggered terminal block

### 3.7 Accessory Connection Leads

Accessory terminals are assembled onto connectors whenever the motor is supplied with a terminal block. They may be assembled inside the main power terminal box or in a separate accessory terminal box (figure 13).

Whether the accessory terminals are assembled inside the main power or a separate terminal box, an M20x1,5 threaded hole is provided for fitting of cable glands for the incoming connection leads.

In the Terminal Box Drawings Section of this technical catalogue it is possible to check the permissible number of connectors which may be assembled inside the main power and accessory terminal boxes.



Figure 13 - Accessory terminal box attached to power terminal box

For all frame sizes, there is also the option of providing a dedicated terminal box for the connection of space heaters, or two separate accessory terminal boxes, as shown in figure 14.

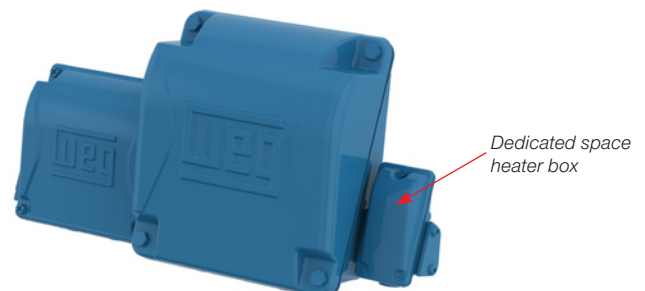

Figure 14 - Two accessory terminal boxes attached to power terminal box

### 3.8 Endshields

The drive end shield (figure 15) is designed with fins for improved thermal heat dissipation, to ensure lower bearing operating temperatures, resulting in extended lubrication intervals.

For the frames 225S/M to 355A/B, where ventilation is critical for thermal performance of the motor, the endshield fastening screws are located in such a way so as not to obstruct the airflow across any cooling fin, thus contributing to better thermal exchange.

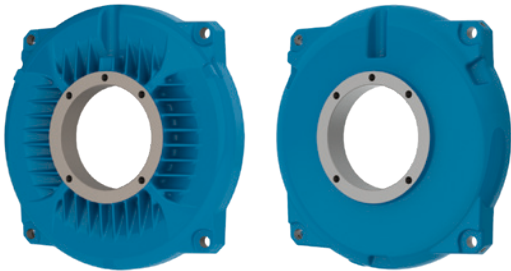

Figure 15 - Drive and non-drive endshields

### 3.9 Drains

The endshields have holes for drainage of any water that may condense inside of the frame. These holes are supplied with rubber drain plugs, as indicated in figure 16. Motors supplied with rubber drain, threaded drain or any other open/close drain plugs must be opened periodically to allow the exit of condensed water. For environments with high water condensation levels and motor with IP55 degree of protection, the drain plugs can be mounted in open position.

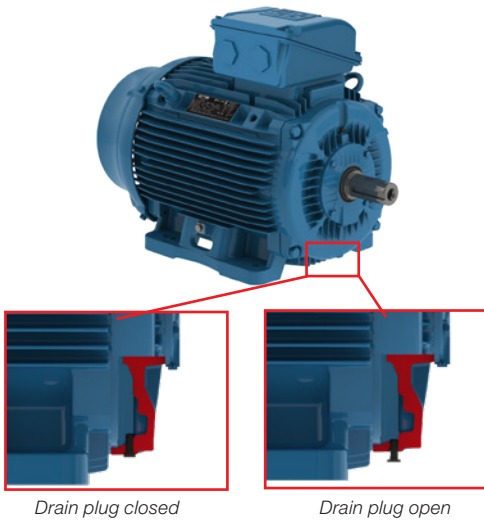

Figure 16 - Detail of the drain plug position on drive endshield.

### 3.10 Fan Cover

The fan cover is made of steel for frames 63 to 132 and FC-200 (EN GJL 200) cast iron for frames 160 to 355. The cast iron fan covers have an aerodynamic design, which results in a significant reduction in noise level and optimized airflow between frame fins for heat exchange improvement. Figure 17 shows the aerodynamic design of the cast iron fan cover.



Figure 17 - Fan cover

### 3.11 Nameplate

The nameplate details information relating to the construction and performance characteristics of the motor. It is also necessary to indicate on the nameplate the IE code and nominal efficiency of the motor at full load (and 3/4 and 1/2 load where space permits), as required by IEC 60034-30-1.

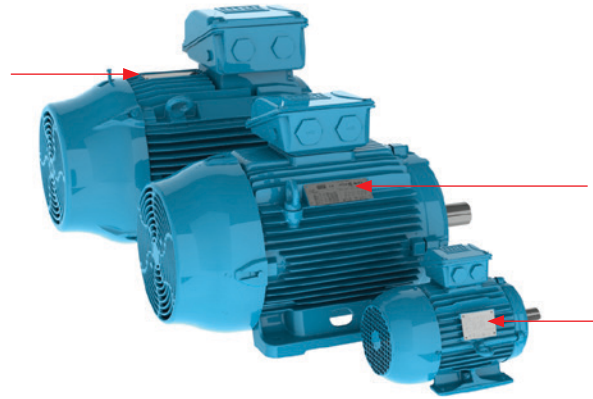

Figure 18 - Nameplate position of W22 motors

W22 Premium		1 → 12862390	
6 →	3~132S-02	8 →	INS CL F ΔT 80 K S1
2 →	V 10 →	12 →	04AGO14
3 →	Hz kW RPM	9 →	15 → AMB 40°C
	380 Δ / 660 Y	4 →	0000000000
	400 Δ / 690 Y	13 →	SF 1.00
	415 Δ / -	14 →	PF
	460 Δ / -	15 →	IE code
		16 →	η100% η75% η50%
		17 →	90.1 90.1 89.2
		18 →	90.3 89.8 88.5
		19 →	90.3 89.7 87.9
		20 →	90.2 89.3 86.9
		21 →	IP55 → DES A
		22 →	MOBIL POLYREX EM
		23 →	6207-ZZ
		24 →	MOD.TE1BF0X0\$
			IEC 60034-1

Figure 19 - Nameplate layout for frames 63 to 132

W22 Premium		1 → 12862390	
6 →	3~315S/M-04	8 →	INS CL F ΔT 80 K S1
2 →	V 10 →	12 →	04AGO14
3 →	Hz kW RPM	9 →	15 → AMB 40°C
	380 Δ / 660 Y	4 →	0000000000
	400 Δ / 690 Y	13 →	SF 1.00
	415 Δ / -	14 →	PF
	460 Δ / -	15 →	IE code
		16 →	η100% η75% η50%
		17 →	95.5 95.5 94.7
		18 →	95.5 95.4 94.4
		19 →	95.8 95.0 93.7
		20 →	IP55 → DES A
		21 →	MOBIL POLYREX EM
		22 →	6308-ZZ
		23 →	6207-ZZ
		24 →	MOD.TE1BF0X0\$
			IEC 60034-1

Figure 20 - Nameplate layout for frames 160 to 355

- 1 - Motor code
- 2 - Number of phases
- 3 - Rated operating voltage
- 4 - Service duty
- 5 - Efficiency Code - IE
- 6 - Frame size
- 7 - Degree of protection
- 8 - Insulation class
- 9 - Temperature rise
- 10 - Frequency
- 11 - Motor rated power
- 12 - Full load speed (rpm)
- 13 - Rated operating current
- 14 - Power factor
- 15 - Ambient temperature
- 16 - Service factor
- 17 - Altitude
- 18 - Motor weight
- 19 - Drive end bearing type and amount of grease (where applicable)
- 20 - Non-drive end bearing type and amount of grease (where applicable)
- 21 - Type of grease for bearings
- 22 - Connection diagram
- 23 - Relubrication intervals in hours
- 24 - Certification labels
- 25 - Manufacturing date
- 26 - Serial number
- 27 - Partial load efficiencies
- 28 - Cooling method
- 29 - Design

## 4. Cooling System and Noise Level / Vibration Level / Impact Resistance

### 4.1 Cooling System

The W22 standard motors are totally enclosed fan cooled (TEFC - IC 411), as per IEC 60034-6 (figure 21). Non-ventilated versions (TENV - IC 410), air over (TEAO - IC 418) and motors with forced ventilation (TEBC - IC416) are available on request. Further information regarding the TEBC - IC 416 option can be found in Section 13 - Variable speed drive application.



Figure 21 - Cooling system

The cooling system (fan, non drive endshield and fan cover) is designed to minimize the noise level and improve thermal efficiency (figure 22).

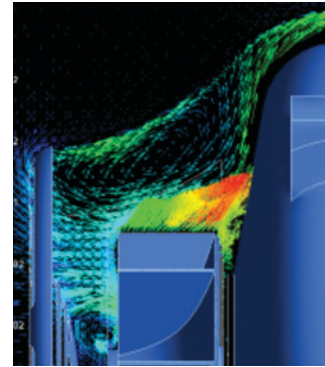

Figure 22 - Cooling system operation

### 4.2 Noise Level

W22 motors comply with IEC 60034-9 Standard and the corresponding sound pressure levels. Tables 4 and 5 show sound pressure levels in dB(A) which are obtained upon tests at 50 Hz and 60 Hz.

IEC 50 Hz				
Frame	Sound pressure level - dB(A) at 1 meter			
	2 poles	4 poles	6 poles	8 poles
63	52	44	43	-
71	56	43	43	41
80	59	44	43	42
90	64/ 62(*)	49	45	43
100	67	53	44	50
112	64	56	48	46
132	68/ 67(*)	60/ 56(*)	52	48
160	67	61	56	51
180	67	61	56	51
200	72/ 69(*)	65/ 63(*)	60	53
225	75/ 74(*)	66/ 63(*)	61	56
250	75/ 74(*)	66/ 64(*)	61	56
280	77	69	65	59
315S/M	77	71	67	61
315 L	78	74/ 73(*)	68	61
355M/L	80	76/ 74(*)	73	70
355A/B	83	76	73	70

(\*) Values for IE3 and IE4 motors.

Table 4 - Sound pressure levels for 50 Hz motors

IEC 60 Hz				
Frame	Sound pressure level - dB(A) at 1 meter			
	2 poles	4 poles	6 poles	8 poles
63	56	48	47	-
71	60	47	47	45
80	62	48	47	46
90	68	51	49	47
100	71	54	48	54
112	69	58	52	50
132	72	61	55	52
160	72	64	59	54
180	72	64	59	54
200	76/ 74(*)	68/ 66(*)	62	56
225	80/ 79(*)	70/ 67(*)	64	60
250	80/ 79(*)	70/ 68(*)	64	60
280	81	73	69	63
315S/M	81	75	70	64
315 L	82	79/ 77(*)	71	64
355M/L	84	81/ 78(*)	77	75
355A/B	89	81	77	75

(\*) Values for IE3 and IE4 motors.

Table 5 - Sound pressure levels for 60 Hz motors

The noise level values shown in tables 4 and 5 are taken at 1 metre at no load. Under load the IEC 60034-9 Standard foresees an increase of the sound pressure levels as shown in table 6.

Frame (mm)	2 poles	4 poles	6 poles	8 poles
90 ≤ H ≤ 160	2	5	7	8
180 ≤ H ≤ 200	2	4	6	7
225 ≤ H ≤ 280	2	3	6	7
H = 315	2	3	5	6
355 ≤ H	2	2	4	5

Table 6 - Maximum expected increase of sound pressure level for loaded motors.

Note: These values refer to operating frequencies of 50 Hz and 60 Hz.

The overall noise level can be reduced by up to 2 dB (A) with the installation of a drip cover.

### 4.3 Vibration Level

Vibration of an electrical machine is closely related to its assembly on the application and, thus, it is generally desirable to perform vibration measurements under installation and operational conditions. However, to allow evaluation of the vibration generated by the electrical machine itself in a way to allow reproducibility of the tests and the obtaining of comparative measurements, it is necessary to perform such measurements with the machine uncoupled, under controlled test conditions. The test conditions and vibration limits described here are those found in IEC 60034-14. The severity of vibration is the maximum value of vibration found among all the recommended measurement points and directions. Table 7, below, indicates the recommended admissible values of vibration severity under IEC standard 60034-14 for the frames IEC 56 to 400, for degrees of vibration A and B.

W22 motors (> frame 80, 2P and > frame 71, 4P and up) are dynamically balanced with half key and the standard version meets the vibration levels of Grade A (without special vibration requirements) described in IEC 60034-14 Standard. As an option, motors can be supplied in conformance with vibration of Grade B. The RMS speed and vibration levels in mm/s of Grades A and B are shown in table 7.

Vibration	Frame	56 ≤ H ≤ 132	132 < H ≤ 280	H > 280
	Assembly	Vibration speed RMS (mm/s)	Vibration speed RMS (mm/s)	Vibration speed RMS (mm/s)
Grade A	Free suspension	1,6	2,2	2,8
Grade B	Free suspension	0,7	1,1	1,8

Table 7 - Speed and vibration levels

### 4.4 Impact Resistance

The W22 motor complies with impact level IK08 (mechanical impact of 5J) as defined in EN 62262:2002 - Degrees of protection provided by enclosures for electrical equipment against external mechanical impacts (IK code) - therefore ensuring superior mechanical strength for the most demanding applications.

## 5. Shaft / Bearings

### 5.1 Shaft

The shaft steel material for W22 standard motors is AISI 1040/45, in frames IEC 63 to 315S/M, and AISI 4140 for frames 315L, 355M/L and 355A/B. When supplied with roller bearings, the shaft material must be AISI 4140. Information regarding the maximum allowable radial and axial loads on shaft ends is given in tables 9, 10 and 11.

Important: when equipped with a roller bearing, it is necessary to lock the non-drive end bearing which obliges replacement of the non-drive end bearing cap.

Shafts of W22 motors are supplied with an open profile keyway, with a threaded centre hole, and can optionally be provided with a second shaft end. Dimensions of motor shafts can be found in Section 18 - Mechanical Data. For highly corrosive environments, W22 motors may also be supplied with AISI 316 or AISI 420 stainless steel shafts.

Note: 2 pole motors will have as an option only the shaft end in stainless steel AISI 316.

### 5.2 Bearings

W22 motors are supplied with deep groove ball bearings as standard (figure 23). Optionally, for frame sizes 132 and above, NU series roller bearings can be fitted to motors intended for heavy duty applications where high radial loads may occur e.g. pulley and belt drives.



Figure 23 - Ball bearing view

The nominal bearing life L10h is 20.000 or 40.000 hours in conformance with maximum radial and axial loads as described in tables 9, 10 and 11. When direct coupled to the load (without axial or radial thrusts), the L10h bearing life can be extended to 50.000\* hours.

\* For regreasable motors. Other configurations contact WEG.

In standard configuration, with ball bearings, the drive end bearing is locked axially from frame 160. To compensate for any axial movement the motors are fitted with pre-load washers for frames 63 to 200 and with pre-load springs for frames 225 to 355. When provided with roller bearings, the non-drive end bearing is locked and the axial movement is compensated by the axial play of the front roller bearing. Minimum and maximum admissible radial loads for roller bearings are shown in table 10 on page 16.

The lifetime of the bearing is dependent on its type and size,

the radial and axial mechanical loads it is submitted to, operating conditions (environment, temperature, mounting orientation), rotational speed and grease life. Therefore, bearing lifetime is closely related to its correct use, maintenance and lubrication. Respecting the quantity of grease and lubrication intervals allows bearings to reach the indicated lifetime. W22 motors in IEC frames 225S/M and above are provided as standard with grease fittings in each endshield to permit the relubrication of the bearings (optional for frames 90 to 200). The quantity of grease and lubrication intervals are stamped on the motor nameplate. The lubrication intervals are shown in tables 12 and 13 on page 17. It must be emphasized that excessive lubrication, i.e. a quantity of grease greater than that recommended on the motor nameplate, can result in the increase of bearing temperatures leading to reduced operating hours.

**Note:**

1. L10h lifetime means that at least 90% of the bearings submitted to the maximum indicated loads will reach the number of hours indicated. The maximum admissible radial and axial loads for the standard configuration are shown in tables 9, 10 and 11. The values of the maximum radial load consider axial load as nil. The values of the maximum axial load consider radial load as nil. For bearing lifetimes with combined axial and radial loads condition contact WEG.

2. The radial force value Fr usually results from information recommended in the catalogues of pulley / belt manufacturers.

When this information is not available, the force Fr, under operation, can be calculated based on the output power, on coupling design characteristics with pulleys and belts and on the type of application. So we have:

$$Fr = \frac{19,1 \times 10^6 \times P_n}{n_n \times dp} \times ka \text{ (N)}$$

Where:

- Fr is the radial force caused by pulley and belt coupling [N];
- Pn is the motor rated power [kW];
- nn is the motor rated speed per minute [rpm];
- dp is the pitch diameter of the drive pulley [mm];
- ka is a factor that depends on belt tension and type of application (table 8).

	Groups and basic types of application	ka factor of the application	
		V belts	Plane belts
1	Fans and blowers, centrifugal pumps, winding machines, compressors, machine tools with outputs up to 22 kW (30 HP)	2,0	3,1
2	Fans and blowers, centrifugal pumps, winding machines, compressors, machine tools with outputs higher than 22 kW (30 HP)	2,4	3,3
3	Presses, vibrating screens, piston and screw compressors, pulverisers, helicoidal conveyors, woodworking machines, textile machines, kneading machines, ceramic machines, pulp and paper industrial grinders (for all power range).	2,7	3,4
4	Overhead cranes, hammer mills, metal laminators, conveyors, gyratory crushers, jaw crushers, cone crushers, cage mills, ball mills, rubber mixers, mining machines, shredders (for all power range).	3,0	3,7

Table 8 - ka factor

**Important:**

**1 - Special applications**

Motor operation under adverse operating conditions, such as higher ambient temperatures and altitudes or abnormal axial / radial loads, may require specific lubrication measures and alternative relubrication intervals to those indicated in the tables provided within this technical catalogue.

**2 - Roller bearings**

Roller bearings require a minimum radial load so as to ensure correct operation. They are not recommended for direct coupling arrangements, or for use on 2 pole motors.

**3 - Frequency inverter driven motors**

Bearing life may be reduced when a motor is driven by a frequency drive at speeds above nominal. Speed itself is one of the factors taken into consideration when determining motor bearing life.

**4 - Motors with modified mounting configurations**

For motors supplied with horizontal mounting but working vertically, lubrication intervals must be reduced by half.

**5 - Figures for radial thrusts**

The figures given in the tables below for radial thrusts take into consideration the point upon which the load is applied, either at the centre of the shaft (L/2) or at the end of the shaft (L), figure 24.

Note: On motors with second shaft end, refer to WEG for details of the maximum permissible axial and radial loads.

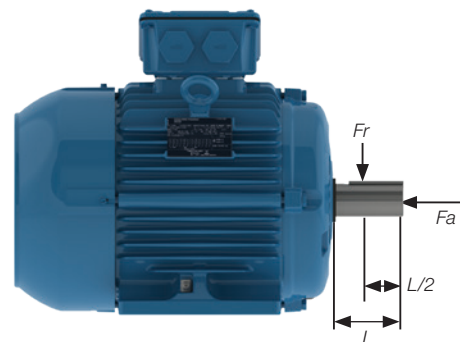

Figure 24 - Radial and axial thrust on motor shaft

**5.2.1 Permissible Loads**

**Radial Thrust - Ball Bearings**

Frame	Maximum permissible radial thrust - 50 Hz - Fr in (kN) 20.000 hours							
	2 poles		4 poles		6 poles		8 poles	
	L	L/2	L	L/2	L	L/2	L	L/2
63	0,3	0,4	0,3	0,4	0,3	0,4	0,3	0,4
71	0,5	0,5	0,5	0,6	0,5	0,6	0,6	0,7
80	0,6	0,6	0,7	0,7	0,7	0,8	0,8	1,0
90	0,6	0,7	0,7	0,8	0,8	0,9	0,9	1,0
100	0,9	1,0	1,0	1,1	1,2	1,3	1,3	1,4
112	1,2	1,3	1,4	1,5	1,6	1,8	1,7	1,9
132	1,8	2,0	2,2	2,4	2,4	2,7	2,6	2,9
160	2,3	2,6	2,6	2,9	2,7	3,3	2,7	3,7
180	3,1	3,5	3,6	4,0	4,2	4,7	4,2	5,2
200	3,7	4,0	4,2	4,7	4,9	5,4	5,7	6,2
225	5,1	5,5	5,2	6,3	5,3	7,0	5,7	8,1
250	4,9	5,3	5,2	5,7	6,5	7,1	6,0	8,2
280	5,0	5,4	6,7	7,2	7,8	8,4	8,7	9,4
315S/M	4,3	4,7	7,0	7,7	8,1	8,8	9,0	9,8
315L	4,6	5,0	4,0	7,3	6,2	8,2	9,1	9,8
355M/L	4,8	5,1	8,5	9,3	9,6	10,4	11,6	12,6
355A/B	4,5	4,7	5,1	7,4	7,4	8,0	6,9	10,6

Table 9.1 - Maximum permissible radial thrusts for ball bearings (horizontal mounting)

### Radial Thrust - Ball Bearings

Maximum permissible radial thrust - 50 Hz - Fr in (kN) 40.000 hours								
Frame	2 poles		4 poles		6 poles		8 poles	
	L	L/2	L	L/2	L	L/2	L	L/2
63	0,2	0,2	0,3	0,3	0,3	0,4	0,3	0,4
71	0,3	0,3	0,4	0,4	0,5	0,5	0,5	0,6
80	0,5	0,5	0,5	0,6	0,6	0,6	0,7	0,7
90	0,5	0,5	0,5	0,6	0,6	0,7	0,7	0,8
100	0,7	0,7	0,7	0,8	0,9	1,0	1,0	1,1
112	0,9	1,0	1,0	1,1	1,2	1,4	1,3	1,4
132	1,4	1,6	1,6	1,8	1,8	2,0	2,0	2,2
160	1,8	2,0	1,9	2,1	2,2	2,4	2,5	2,7
180	2,4	2,7	2,7	3,0	3,2	3,5	3,6	3,9
200	2,8	3,0	3,2	3,5	3,7	4,0	4,3	4,7
225	3,9	4,3	4,3	4,7	4,7	5,2	5,6	6,2
250	3,7	4,1	3,8	4,2	4,9	5,4	5,7	6,3
280	3,8	4,1	4,9	5,4	5,8	6,3	6,5	7,0
315S/M	3,1	3,4	4,9	5,4	5,7	6,2	6,3	6,9
315L	3,4	3,6	4,0	4,9	5,1	5,5	6,4	6,9
355M/L	3,3	3,6	5,8	6,3	6,5	7,1	8,2	8,9
355A/B	3,0	3,2	4,1	4,4	4,2	4,5	5,3	6,8

Table 9.2 - Maximum permissible radial thrusts for ball bearings (horizontal mounting).

### Radial Thrust - Roller Bearings

Maximum permissible radial thrust - 50 Hz - Fr in (kN) 40.000 hours						
Frame	4 poles		6 poles		8 poles	
	L/2	L	L/2	L	L/2	L
160	5,0	3,2	5,1	3,3	5,1	3,3
180	8,8	5,5	8,8	5,6	8,8	5,6
200	11,2	7,3	11,2	7,4	11,3	7,4
225S/M	12,9	7,6	12,9	7,6	13,0	7,8
250S/M	13,7	8,9	13,8	8,9	13,7	8,9
280S/M	19,3	12,6	19,4	12,8	19,6	12,9
315S/M	25,8	12,9	27,4	13,0	27,4	13,2
315L	21,5	10,1	20,1	9,4	26,1	12,2
355M/L	34,0	17,3	33,5	16,4	33,5	16,1
355A/B	31,4	14,9	25,4	12,0	28,4	13,5

Table 10 - Maximum permissible radial thrusts for roller bearings (horizontal mounting)

Note: the values given for roller bearings consider AISI 4140 steel shafts.

### Axial Thrust - Ball Bearings

Maximum permissible axial thrust - 50 Hz - Fa in (kN) - 20.000 hours							
Frame	Poles	Horizontal		Vertical with shaft upwards		Vertical with shaft downwards	
		Pushing	Pulling	Pushing	Pulling	Pushing	Pulling
63	2	0,2	0,2	0,2	0,2	0,2	0,2
	4	0,3	0,3	0,3	0,3	0,3	0,3
	6	0,3	0,4	0,3	0,4	0,4	0,3
	8	0,3	0,4	0,3	0,4	0,4	0,3
71	2	0,2	0,3	0,2	0,3	0,2	0,3
	4	0,3	0,4	0,3	0,4	0,3	0,4
	6	0,4	0,5	0,4	0,5	0,4	0,5
	8	0,5	0,6	0,4	0,6	0,5	0,6
80	2	0,3	0,4	0,3	0,4	0,3	0,4
	4	0,4	0,6	0,3	0,6	0,4	0,5
	6	0,5	0,7	0,4	0,7	0,5	0,7
	8	0,6	0,8	0,5	0,9	0,6	0,8
90	2	0,4	0,4	0,3	0,5	0,4	0,4
	4	0,5	0,6	0,5	0,7	0,5	0,6
	6	0,6	0,7	0,6	0,8	0,6	0,7
	8	0,8	0,9	0,7	0,9	0,8	0,8
100	2	0,4	0,6	0,3	0,7	0,4	0,6
	4	0,5	0,8	0,4	0,9	0,5	0,8
	6	0,7	1	0,6	1,1	0,7	1
	8	0,8	1,2	0,7	1,3	0,8	1,1
112	2	0,5	0,8	0,5	0,9	0,6	0,7
	4	0,7	1,1	0,7	1,2	0,8	1
	6	1	1,4	0,9	1,5	1	1,3
	8	1,1	1,5	1	1,7	1,1	1,4
132	2	0,7	1,3	0,6	1,5	0,8	1,2
	4	1	1,8	0,8	2,1	1	1,7
	6	1,2	2,2	1,1	2,5	1,3	2,1
	8	1,4	2,5	1,2	2,8	1,4	2,3
160	2	2,4	1,7	0,2	2,1	2,8	1,5
	4	3	2,3	2,7	2,7	3,4	2
	6	3,4	2,7	3,1	3,3	4	2,4
	8	3,9	3,2	3,6	3,7	4,4	2,9
180	2	3,2	2,3	2,9	2,8	3,7	2
	4	3,9	3	3,6	3,7	4,6	2,7
	6	4,7	3,8	4,2	4,5	5,3	3,3
	8	5,2	4,4	4,8	5,1	6	3,9
200	2	3,6	2,6	3,1	3,3	4,3	2,1
	4	4,5	3,5	4	4,3	5,3	3
	6	5,2	4,2	4,7	5,1	6,1	3,7
	8	6	5	5,5	5,9	6,9	4,5
225	2	4,6	3,8	3,8	4,9	5,7	3,1
	4	5,8	5	5	6,3	7,1	4,2
	6	6,7	5,9	5,7	7,6	8,4	4,9
	8	7,8	7	6,9	8,5	9,3	6,1
250	2	4,5	3,7	3,7	4,9	5,6	3
	4	5,4	4,7	4,2	6,6	7,4	3,4
	6	6,8	6	5,4	8	8,8	4,6
	8	7,8	7,1	6,6	8,9	9,7	5,9
280	2	4,4	3,7	3,2	5,4	6,2	2,4
	4	6,3	5,5	4,6	8	8,8	3,9
	6	7,6	6,8	5,8	9,4	10,2	5
	8	8,5	7,8	6,6	10,6	11,4	5,8
315S/M	2	4,1	3,3	2,4	5,9	6,7	1,6
	4	6,8	6	4,3	10	10,7	3,5
	6	8	7,2	5,2	11,9	12,7	4,5
	8	9,1	8,3	6,2	13,2	14	5,5
315L	2	3	2,2	1,1	5	5,7	0,4
	4	4,5	3,7	1,4	8,2	8,9	0,6
	6	5,2	4,4	1,9	9,5	10,3	1,2
	8	6,3	5,5	3,4	10	10,8	2,6
355M/L	2	4,4	3,7	1,1	8,8	9,5	0,3
	4	7,7	7	3,2	13,9	14,7	2,5
	6	9,1	8,4	4,7	15,3	16	3,9
	8	10,9	10,2	6,4	17,2	17,9	5,7
355A/B	2	4,1	3,3	On request			
	4	6,8	6				
	6	7,8	7				
	8	9,8	9				

Table 11.1 - Maximum permissible axial thrusts for ball bearings (horizontal mounting).



### Axial Thrust - Ball Bearings

Maximum permissible axial thrust - 50 Hz - Fa in (kN) - 40.000 hours							
Frame	Poles	Horizontal		Vertical with shaft upwards		Vertical with shaft downwards	
		Pushing	Pulling	Pushing	Pulling	Pushing	Pulling
63	2	0,1	0,1	0,1	0,1	0,1	0,1
	4	0,2	0,2	0,2	0,2	0,2	0,2
	6	0,2	0,2	0,2	0,2	0,2	0,2
	8	0,2	0,2	0,2	0,2	0,2	0,2
71	2	0,1	0,2	0,1	0,2	0,1	0,2
	4	0,2	0,3	0,2	0,3	0,2	0,2
	6	0,2	0,3	0,2	0,3	0,2	0,3
	8	0,3	0,4	0,3	0,4	0,3	0,4
80	2	0,2	0,3	0,1	0,3	0,2	0,3
	4	0,2	0,4	0,2	0,4	0,2	0,3
	6	0,3	0,5	0,3	0,5	0,3	0,4
	8	0,4	0,6	0,3	0,6	0,4	0,5
90	2	0,2	0,3	0,2	0,3	0,2	0,2
	4	0,3	0,4	0,3	0,4	0,3	0,3
	6	0,4	0,5	0,4	0,5	0,4	0,4
	8	0,5	0,6	0,5	0,6	0,5	0,5
100	2	0,2	0,4	0,2	0,4	0,2	0,3
	4	0,3	0,5	0,2	0,6	0,3	0,5
	6	0,4	0,7	0,3	0,8	0,4	0,6
	8	0,5	0,8	0,4	0,9	0,5	0,7
112	2	0,3	0,5	0,3	0,6	0,3	0,4
	4	0,4	0,7	0,4	0,8	0,5	0,6
	6	0,6	0,9	0,5	1,1	0,6	0,8
	8	0,7	1	0,6	1,2	0,7	0,9
132	2	0,4	0,9	0,3	1,1	0,5	0,8
	4	0,6	1,2	0,5	1,4	0,6	1,1
	6	0,8	1,5	0,6	1,8	0,8	1,3
	8	0,9	1,7	0,7	2	0,9	1,5
160	2	1,8	1,1	1,6	1,5	2,2	0,9
	4	2,2	1,5	1,9	1,9	2,6	1,2
	6	2,5	1,8	2,2	2,3	3,1	1,5
	8	2,9	2,2	2,5	2,7	3,4	1,8
180	2	2,4	1,5	2,1	2	2,9	1,2
	4	2,9	2	2,5	2,6	3,5	1,6
	6	3,4	2,5	3	3,2	4,1	2,1
	8	3,9	3	3,5	3,7	4,6	2,6
200	2	2,7	1,7	2,2	2,4	3,4	1,2
	4	3,3	2,3	2,8	3,1	4,1	1,8
	6	3,8	2,8	3,3	3,8	4,8	2,3
	8	4,4	3,4	3,9	4,3	5,3	2,9
225	2	3,4	2,6	2,7	3,7	4,5	1,9
	4	4,2	3,5	3,4	4,7	5,5	2,6
	6	4,8	4	3,8	5,7	6,5	3
250	8	5,7	4,9	4,8	6,4	7,1	4,1
	2	3,4	2,5	2,5	3,7	4,5	1,8
	4	3,9	3,1	2,6	5	5,9	1,8
	6	4,9	4,1	3,6	6,2	7	2,8
280	8	5,8	4,9	4,5	6,8	7,6	3,8
	2	3,3	2,5	2	4,3	5,1	1,2
	4	4,6	3,8	2,9	6,2	7	2,1
	6	5,4	4,7	3,6	7,3	8	2,8
315	8	6,1	5,4	4,2	8,2	9	3,4
	2	2,9	2,2	1,2	4,8	5,5	0,4
	4	4,7	4	2,2	7,9	8,6	1,4
	6	5,6	4,8	2,8	9,4	10,2	2
315L	8	6,4	5,6	3,4	10,4	11,2	2,6
	2	3	2,2	1,1	5	5,7	0,4
	4	4,5	3,7	1,4	8,2	8,9	0,6
	6	5,2	4,4	1,9	9,5	10,3	1,2
355M/L	8	6,3	5,5	3,4	10	10,8	2,6
	2	3,1	2,4	0,6	6,7	7,5	0,2
	4	5,5	4,7	1,9	1,1	11,6	1,2
	6	6,3	5,6	2,8	11,8	12,7	2
355A/B	8	7,6	6,8	3,8	13,2	13,7	2,9
	2	2,9	2,2	On request			
	4	4,6	3,9				
	6	5,2	4,5				
8	6,5	5,8					

Table 11.2 - Maximum permissible axial thrusts for ball bearings (horizontal mounting)

### Lubrication Intervals (Ambient ≤ 40°C at Rated Speed)

Lubrication intervals (hours)			
Frame	Poles	50 Hz	60 Hz
160	2	25000	25000
	4		
	6		
	8		
180	2	25000	25000
	4		
	6		
	8		
200	2	25000	25000
	4		
	6		
	8		
225	2	5000	4000
	4	14000	12000
	6	20000	17000
	8	24000	20000
250	2	5000	4000
	4	14000	12000
	6	20000	17000
	8	24000	20000
280	2	5000	4000
	4	13000	10000
	6	18000	16000
	8	20000	20000
315	2	5000	4000
	4	11000	8000
	6	16000	13000
	8	20000	17000
355	2	5000	4000
	4	9000	6000
	6	13000	11000
	8	19000	14000

Table 12 - Lubrication intervals for ball bearings (horizontal mounting).

Note: the amount of grease is indicated on the nameplate.

Lubrication intervals (hours)			
Frame	Poles	50 Hz	60 Hz
160	4	25000	25000
	6		
	8		
180	4	25000	25000
	6		
	8		
200	4	25000	21000
	6		25000
	8		
225	4	11000	9000
	6	16000	13000
	8	20000	19000
250	4	11000	9000
	6	16000	13000
	8	20000	19000
280	4	9000	7000
	6	14000	12000
	8	19000	17000
315	4	7000	5000
	6	12000	9000
	8	17000	15000
355	4	5000	4000
	6	9000	7000
	8	14000	13000

Table 13 - Lubrication intervals for roller bearings (horizontal mounting).

Note: the amount of grease is indicated on the nameplate.

### 5.2.2 Bearing Monitoring

W22 motors can, on request, be equipped with bearing temperature detectors to provide continuous monitoring of bearing operating conditions. Most commonly used is the Pt-100 temperature detector

This type of monitoring is extremely important considering that it directly affects the grease and bearing lives particularly on motors equipped with regreasing facilities.

## 6. Mounting Forms

Motors are supplied, as standard, in the B3T foot configuration, with the terminal box on top.



Figure 25 - B3T mounting

The mounting configuration for the W22 motor lines comply with IEC 60034-7 standard. Standard mounting forms and their variations are shown in table 14. After the designation, a characteristic letter is used to define the terminal box position. So, the mounting code IM B3 can be seen in WEG documents as detailed below (without IM code).

- B3L - terminal box on left hand side of the motor frame
- B3T - terminal box on top of the motor frame
- B3R - terminal box on right hand side of the motor frame

Note: The terminal box position is defined viewing the motor from the shaft end. Mounting forms and their variations are indicated in table 14.

Basic mountings	Other type of mounting				
IM B3	IM V5	IM V6	IM B6	IM B7	IM B8
IM 1001	IM 1011	IM 1031	IM 1051	IM 1061	IM 1071
IM B35	IM V15	IM V36	- *)	- *)	- *)
IM 2001	IM 2011	IM 2031	IM 2051	IM 2061	IM 2071
IM B34	IM V17	IM V37	- *)	- *)	- *)
IM 2101	IM 2111	IM 2131	IM 2151	IM 2161	IM 2171
IM B5	IM V1	IM V3	IM B30		
IM 3001	IM 3011	IM 3031			
IM B14	IM V18	IM V19			
IM 3601	IM 3611	IM 3631			

Table 14 - Mountings configurations

\* Non-defined mountings by IEC 60034-7.

### Important:

- The mountings IM B34 and IM B14 with C-DIN flange, in accordance with standard EN 50347, are limited to frame size 132. As an option, C Flanges in accordance with NEMA MG 1 Part 4 standard are available for frames 63 to 355M/L.
- For motors mounted vertically shaft down fitting of a drip cover / impact canopy is recommended to prevent ingress of small objects into the fan cover. The increase in total length of the motor with drip cover / impact canopy is shown in the Section 20.
- For motors mounted vertically with shaft up and installed in environments containing liquids, the use of a rubber slinger is recommended to prevent the ingress of liquid into the motor through the shaft.

## 7. Degree of Protection / Sealing System / Painting

### 7.1 Degree of Protection

As per IEC 60034-5, the degree of protection of a rotating electrical machine consists of the letters IP (ingress protection), followed by two characteristic numerals, with the following definitions:

- First characteristic numeral: refers to protection of persons against or approach to live parts and against contacts with moving parts (other than smooth rotating shafts and the like) inside the enclosure and protection of the machine against ingress of solid and foreign objects.
- Second characteristic numeral: protection of machines against harmful effects due to ingress of water.



As standard, W22 motors have the degree of protection IP55. According to IEC 60034-5, this defines the degree of protection as follows:

- a) First characteristic numeral 5: machine protected against dust. The enclosure is protected against contact with moving parts. Ingress of dust is not totally prevented, but dust does not enter in sufficient quantity to interfere with satisfactory operation of the machine.
- b) Second characteristic numeral 5: Machine protected against water jets. Water projected by a nozzle against the machine from any direction shall have no harmful effect.

### 7.2 Sealing System

V-Ring seals are utilized on the shafts of W22 foot mounted motors in frame sizes 63 to 200. For frames 225S/M to 355A/B shaft sealing is provided using the exclusive WSeal®, which consists of a double lipped V-Ring with a metallic cap (see figure 26).

This configuration operates like a labyrinth preventing ingress of water and dust into the motor.

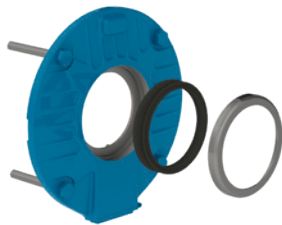

Figure 26 - WSeal®

Alternatively, W22 motors are available with other sealing arrangements, for example, oilseal, taconite labyrinth and the WEG exclusive W3 Seal® (see Section 16 - Optional features). When fitted with a flange, the recommended seal is either a lip seal (no contact with liquid) or oilseal (direct contact with liquid).

### 7.3 Painting

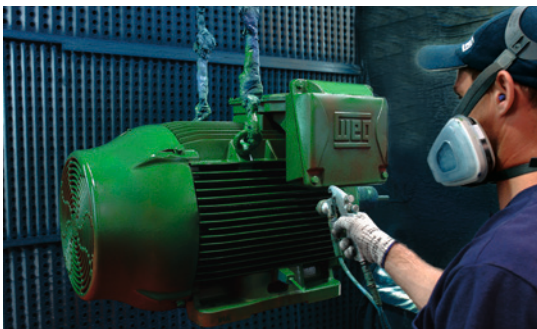

Figure 27 - WEG internal painting plan

The standard painting plans utilized on W22 motors meet the atmospheric corrosive category “C2” as indicated in the DIN EN ISO 12944-2 standard. They are designed for use on motors installed in normal environments, slightly severe, sheltered or non-sheltered, for industrial use, with low relative humidity, normal temperature variations and the presence of SO<sub>2</sub>.

Motor frame sizes 63 to 132 utilize WEG internal painting plan 207A (semi-matt), which consists of:

Primer: One coat of red oxide, alkyd based primer, with minimum thickness of 20 μm.

Finishing: One coat of styrenated alkyd based synthetic enamel paint, with minimum thickness of 30 μm.

And, motors in frame sizes 160-355 utilise the WEG internal paint plan 203A (semi-gloss):

Primer: One coat of red oxide, alkyd based primer, with minimum dry coat thickness of 20 μm.

Finishing: One coat of alkyd based synthetic enamel paint, with minimum dry coat thickness of 40 μm.

**Note:**

These painting plans are not recommended for direct exposure to acid steam, alkalis, solvents and salty environments.

Alternative painting plans are available on request, which are suitable to guarantee additional protection in aggressive environments, either protected or unprotected (see section 16 - Optional features).

### 7.3.1 Tropicalized Painting

The integrity of the insulation system is the primary consideration when determining the lifetime of an electric motor. High humidity can result in premature deterioration of the insulation system, therefore for any ambient temperature with relative humidity above 95%, it is recommended to coat all internal components of the motor with an epoxy painting, also known as tropicalization.

## 8. Voltage / Frequency

As defined in IEC 60034-1 the combination of voltage and frequency variations are classified as Zone A or Zone B, as per figure 28.

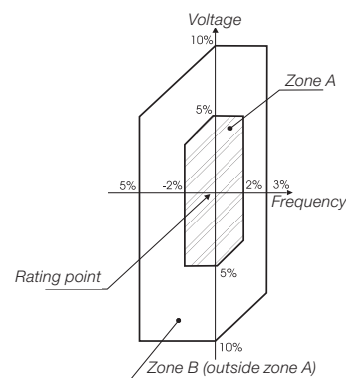

Figure 28 - Rated voltage and frequency limits for electric motors

IEC 60034-1 states that the motor must be suitable to perform its main function (supply torque) continuously within Zone A. However, this motor may not fully meet its performance characteristics due to power supply voltage and frequency variation, which can result in temperature rise above the rated value.

The motor must also be suitable to perform its main function (supply torque) at Zone B. However, the performance characteristic changes will be greater than those operating in Zone A. The temperature rise will also be higher than that at rated voltage and frequency and when operating within Zone A. Prolonged operation near the boundaries of Zone B is not recommended.

## 9. Overload Capacity

As per IEC 60034-1, motors having rated output not exceeding 315 kW and rated voltages not exceeding 1 kV shall be capable of withstanding a current equal to 1,5 times the rated current for not less than 2 minutes.

## 10. Ambient and Altitude

Unless otherwise specified, the rated outputs shown in the electrical data tables within this catalogue refer to continuous duty operation S1, as per IEC 60034-1 and under the following conditions:

- ambient temperature range -20 °C to +40 °C
- altitudes up to 1000 metres above sea level

For operating temperatures and altitudes differing from those above, the factors indicated in table 15 must be applied to the nominal motor power rating in order to determine the derated output (Pmax).

$$P_{max} = P_{nom} \times \text{correction factor}$$

T (°C)	Altitude (m)								
	1000	1500	2000	2500	3000	3500	4000	4500	5000
10							0,97	0,92	0,88
15						0,98	0,94	0,90	0,86
20					1,00	0,95	0,91	0,87	0,83
25				1,00	0,95	0,93	0,89	0,85	0,81
30			1,00	0,96	0,92	0,90	0,86	0,82	0,78
35		1,00	0,95	0,93	0,90	0,88	0,84	0,80	0,75
40	1,00	0,97	0,94	0,90	0,86	0,82	0,80	0,76	0,71
45	0,95	0,92	0,90	0,88	0,85	0,81	0,78	0,74	0,69
50	0,92	0,90	0,87	0,85	0,82	0,80	0,77	0,72	0,67
55	0,88	0,85	0,83	0,81	0,78	0,76	0,73	0,70	0,65
60	0,83	0,82	0,80	0,77	0,75	0,73	0,70	0,67	0,62
65	0,79	0,76	0,74	0,72	0,70	0,68	0,66	0,62	0,58
70	0,74	0,71	0,69	0,67	0,66	0,64	0,62	0,58	0,53
75	0,70	0,68	0,66	0,64	0,62	0,60	0,58	0,53	0,49
80	0,65	0,64	0,62	0,60	0,58	0,56	0,55	0,48	0,44

Table 15 - Correction factors for altitude and ambient temperature

## 11. Insulation & Temperature Rise

W22 motors are supplied with class F insulation and Class B (80 K) temperature rise at normal operating conditions (unless otherwise specified).

The difference between the temperature of the class F insulation (105 K) and the temperature rise of the design (80 K) means that, in practice, W22 motors are suitable to deliver outputs above the rated values up to a limit where the temperature rise reaches the temperature rise value of the insulation class.

The ratio between temperature rise and service factor is given by the equation below:

$$\Delta T_{FINAL} \cong (S.F.)^2 \times \Delta T_{INITIAL}$$

From the above calculation, we can conclude that the service factor is approximately 1.15. This reserve of temperature permits W22 motors with class B temperature rise (80 K) to operate continuously under the following conditions:

- Up to 15% above their rated output, considering 40 °C ambient temperature and 1000 m.a.s.l. or;
- At ambient temperatures up to 55°C or altitudes up to 3000 m.a.s.l. maintaining their nominal rated output.

**Important:** Please note that under these conditions the combined ambient and temperature rise may reach class F limits.

Table 16 shows the safety margins per thermal class.

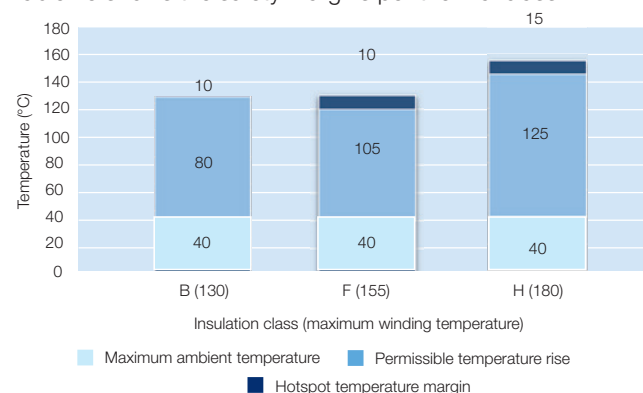

Table 16 - Safety margins per thermal class.

Bearing lubrication intervals will change under operating conditions other than 40 °C maximum ambient temperature and 1000 metres above sea level. Contact WEG for further information.

All W22 motors are wound with the WISE® insulation system which consists of enamelled wire impregnated with solvent free resin which protects motors at temperatures up to 200 °C. The WISE® system also permits motor operation with variable speed drives (see section 13).

### 11.1 Space Heaters

The use of space heaters is recommended in two situations:

- Motors installed in environments with relative air humidity up to 95%, in which the motor may remain idle for periods greater than 24 hours;
- Motors installed in environments with relative air humidity greater than 95%, regardless of the operating schedule. It should be highlighted that in this situation it is strongly recommended that an epoxy painting, more commonly known as tropicalization, is applied to the internal components of the motor. More information can be found in section 7.3.

The supply voltage for space heaters must be defined by the Customer. For all frame sizes, W22 motors can be provided with space heaters suitable for 110-127 V, 220-240 V and 380-480 V. As an option, dual voltage heaters of 110-127 / 220-240 V can be supplied for motor frame sizes 112 to 355A/B, through reconnection of the heater cables inside the terminal box.

The power rating and number of space heaters fitted depends on the size of the motor as indicated in table 17 below:

Frame	Quantities	Total power rated (W)
63 to 80	1	7,5
90 and 100	1	11
112	2	22
132 and 160	2	30
180 and 200	2	38
225 and 250	2	56
280 and 315	2	140
355	2	174

Table 17 - Power and quantity of space heaters

## 12. Motor Protections

Protections available for the W22 motor line can be classified as follows:

- Based on operating temperature
- Based on operating current

Refer to section 15 for further details of the standard and optional protection types available for W22 motors.

### 12.1 Protection Based on Operating Temperature

Continuous duty motors must be protected from overload either by a device integrated into the motor or via an independent protection system, usually a thermal relay with rated or setting current, equal to or below the value obtained when multiplying the power supply rated current ( $I_n$ ), as per table 18.

Service factor	Relay setting current
1,0 up to 1,15	$I_n \times S.F.$
$\geq 1,15$	$(I_n \times S.F.) - 5\%$

Table 18 - Relay setting current referred to service factor

#### 12.1.1 Pt-100



Figure 29 - Pt-100

These are temperature detectors with operating principle based on the properties that some materials vary the electric resistance with the variation in temperature (usually platinum, nickel or copper). They are also fitted with calibrated resistances that vary linearly with temperature, allowing continuous reading of motor operating temperature through a monitoring display, with high precision rate and response sensitivity.

The same detector can serve as alarm (with operation above the regular operating temperature) and trip (usually set up for the maximum temperature of the insulation class).

#### 12.1.2 Thermistor (PTC)



Figure 30 - Thermistor (PTC)

A thermistor is a non-linear resistance temperature detector, made from semi-conductor material. Each specific thermistor has its own unique resistance vs. temperature characteristic i.e. they have one pre-set, non-adjustable tripping point.

PTC (positive temperature coefficient) thermistors have a resistance that increases dramatically at its defined tripping temperature. This sudden variation in resistance blocks the PTC current which causes the output relay to operate and the main circuit to switch off.

Thermistors are compact, do not wear, and feature faster response times when compared to other types of thermal protectors, although they do not allow continuous monitoring of motor operating temperature.

Together with their electronic circuits, these thermistors provide full protection against overheating caused by overload, under or overvoltage or frequent reversing operations.

Where thermistor protection is required to provide both alarm and trip operation, it is necessary for each phase of the motor winding to be equipped with two sets of appropriately rated thermistors.

WEG Automation offers a range of electronic relays 'RPW' intended specifically to read the PTC signal and operate its output relay. For further information please visit the website [www.weg.net](http://www.weg.net).

#### 12.1.3 Bimetallic Thermal Protectors

These are silver-contact thermal sensors, normally closed, that operate at certain temperature rise. When their operating temperature decreases, they return to their original position instantaneously, allowing the silver contact to close again.

The bimetallic thermal protectors are series-connected with the contactor coil, and can be used either as alarm or trip.

There are also other types of thermal protectors such as Pt-1000, KTY and thermocouples. Contact your local WEG office for further information.

### 12.2 Protection Based on Operating Current

Overloads are processes which usually see the temperature increase gradually. To overcome this problem, the thermal protectors described in item 12.1 are quite suitable. However, the only way to protect motors against short-circuit currents is the application of fuses. This type of protection depends directly on the motor current and is highly effective in cases of locked rotor.

WEG Automation supplies a range of fuses in versions D and NH. Visit the website [www.weg.net](http://www.weg.net) for further information.

## 13. Variable Speed Drive Application

### 13.1 Considerations Regarding Voltage Spikes and the Insulation System

The stator windings of W22 motors are wound with class F insulation (class H optional) and are suitable for either DOL starting or via a variable speed drive. They incorporate the WEG exclusive insulation system - WISE® (WEG Insulation System Evolution) - which ensures superior electrical insulation characteristics.

The stator winding is suitable for variable speed drive application, taking into account the limits shown in table 19.

Motor rated voltage	Voltage Spikes <sup>1)</sup>		Rise time <sup>2)</sup>	Time between pulses
	At motor terminals (phase-phase)	$dV/dt$ <sup>2)</sup> At motor terminals (phase-phase)		
$V_{rated} < 460 \text{ V}$	$\leq 1600 \text{ V}$	$\leq 5200 \text{ V}/\mu\text{s}$	$\geq 0,1 \mu\text{s}$	$\geq 6 \mu\text{s}$
$460 \text{ V} \leq V_{rated} < 575 \text{ V}$	$\leq 2000 \text{ V}$	$\leq 6500 \text{ V}/\mu\text{s}$		
$575 \text{ V} \leq V_{rated} \leq 1000 \text{ V}$	$\leq 2400 \text{ V}$	$\leq 7800 \text{ V}/\mu\text{s}$		

1) Peak voltage in the case of unipolar pulses. Peak-to-peak voltage in the case of bipolar pulses.

2)  $dV/dt$  and Rise time definition according to Nema Std. MG1 - Part 30.

Table 19 - Supportability of random wound motors' insulation system.

#### Notes:

- 1 - If one or more of the above conditions is not respected, a filter (load reactor or  $dV/dt$  filter) must be installed in the output of the VSD.

- 2 - General purpose motors with rated voltage greater than 575 V, which at the time of purchase did not have any indication of operation with VSD, are able to withstand the electrical limits set in the table above for rated voltage up to 575 V. If such conditions are not fully satisfied, output filters must be used.
- 3 - General purpose motors of the dual voltage type, for example 400/690 V or 380/660 V, which at the time of purchase were not specified for VSD operation, are permitted to be operated with the VSD at the higher voltage provided that the limits defined in the table above for rated voltage up to 460 V are fully respected. Otherwise, a load reactor or a dV/dt filter must be installed in the VSD output.

### 13.2 Influence of the VSD on the Motor Temperature

Motors operating with frequency inverters may present a higher temperature rise than when operating under sinusoidal supply. This occurs due to the combined effects of the loss increase resulting from the PWM harmonics and the reduction in ventilation experienced by self-ventilated motors when operating at low frequencies. There are basically three solutions to avoid excessive overheating of the motor in VSD applications:

- Torque derating (oversizing of the self-ventilated motor frame size);
- Forced ventilation (use of an independent cooling system);
- Optimal Flux Solution (exclusive to applications where both motor and drive are WEG).

#### 13.2.1 Torque Derating Criteria

In order to maintain the temperature rise of WEG motors within acceptable levels, when supplied by VSD, the speed range-related loadability limits established in figures 31 (for operation under constant flux condition) or 32 (for operation under optimal flux condition) must be observed.

#### Notes:

- 1 - These derating curves relate to the motor thermal capability only and do not concern the insulation class. Speed regulation will depend on VSD mode of operation and proper adjustment.
- 2 - Torque derating is usually necessary when the motor is required to drive constant torque loads (e.g. screw compressors, conveyors, extruders, etc.). For squared torque loads, such as pumps and fans, no torque derating is normally required.
- 3 - W22 motors in frame sizes 90S and above can be blower cooled (independently ventilated) under request. In such cases, the motor will be suitable for VSD operation without torque derating regardless the load type.
- 4 - For operation above base (nameplate) speed, mechanical issues must be also observed. Please refer to table 20 for the maximum limits for safe operation.

#### 13.2.2 Constant Flux Condition

Applicable when the motor is supplied by any commercial drive operating with any control scheme other than the Optimal Flux available in WEG drives.

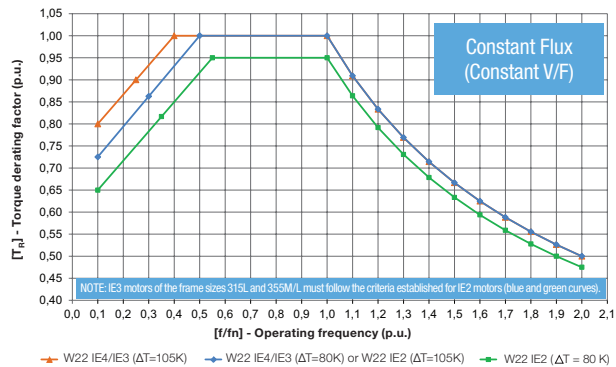

Figure 31 - Derating curves for constant flux condition

#### 13.2.3 Optimal Flux Condition

The study of the composition of the overall motor losses and its relation to operation parameters such as the frequency, the magnetic flux, the current, and the speed variation led to the determination of an optimal flux value for each operating frequency. The implementation of this solution within the CFW-11 and CFW-700 control algorithms mean that the motor optimal flux condition can be automatically applied by the drive throughout the speed range, resulting in a continuous minimization of losses. As a consequence of this loss minimization, the use of the optimal flux control provides higher efficiency and lower temperature rise. Therefore, the torque derating factors for this operating condition are lower than for constant V/f, as shown in figure 32.

The optimal flux solution was developed for low frequency applications with constant torque loads. It should not be used for variable torque loads nor when the operating speed range includes points above the base (rated) frequency. The Optimal Flux Solution may be only applied under the following conditions:

- The motor has an efficiency class IE2 or above;
- The motor is controlled by a WEG drive (CFW-11 or CFW-700);
- Sensorless vector control is used.

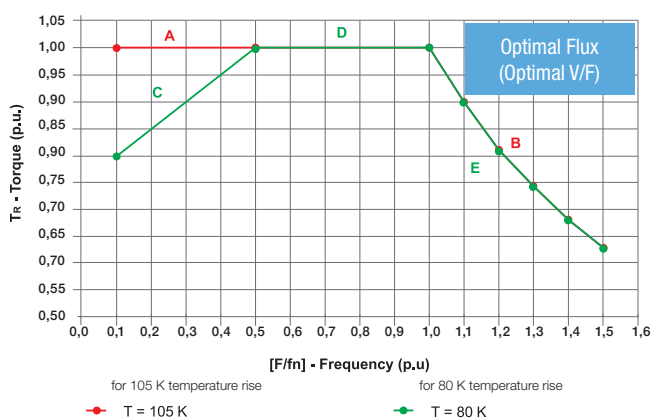

Figure 32 - Derating curves for Optimal Flux condition

Output (kW)	Maximum safe operating speeds (rpm)		
	TEFC Motors		
	2 poles	4 poles	6 poles
0,18	7200	3600	2400
0,25	7200	3600	2400
0,37	7200	3600	2400
0,55	7200	3600	2400
0,75	7200	3600	2400
1,1	7200	3600	2400
1,5	7200	3600	2400
2,2	7200	3600	2400
4,0	7200	3600	2400
5,5	5400	3600	2400
7,5	5400	3600	2400
11	5400	3600	2400
15	5400	3600	2400
18,5	5400	2700	2400
22	5400	2700	2400
30	4500	2700	2400
37	4500	2700	2400
45	3600	2700	2400
55	3600	2700	2400
75	3600	2700	1800
90	3600	2700	1800
110	3600	2700	1800
150	3600	2250	1800
185	3600	2250	1800
220	3600	2250	1800
260	3600	1800	1800
300	3600	1800	-
330	3600	1800	-
370	3600	1800	-

Table 20 - Maximum safe operating speeds (rpm) for W22 motors driven by VSD

**Notes:**

- 1 - The values in table 20 are related to mechanical limitations. For operation above nameplate speed, the electrical limitations (motor torque capability) must be also observed.
- 2 - The limits established in table 20 are in accordance with the IEC 60034-1 Table 17.
- 3 - The permissible overspeed value is 10% above the limits given in Table 20 (not to exceed 2 minutes in duration) except where the maximum safe operating speed is the same as the synchronous speed at 60 Hz - in such case, please contact WEG.
- 4 - Operation above nameplate speed may require specially refined motor balancing. In such case, vibration and noise limits per IEC 60034-14 and IEC 60034-9, respectively, are not applicable.
- 5 - Bearing life will be affected by the length of time the motor is operated at various speeds.
- 6 - For speeds and ratings not covered by the table above, please contact WEG.

**13.3 Considerations Regarding Bearing Currents**

Motors for variable speed drive applications up to frame size 280S/M, do not generally require any special considerations with respects to the bearings. However, for frame sizes 315S/M upwards additional measures should be taken in order to avoid detrimental bearing currents. This can be accomplished by utilisation of an insulated bearing or insulated hub endshield and a shaft grounding brush mounted on the opposite side. W22 motors will normally be supplied duly protected per such recommendations when operation with VSD is specified at the time of purchase. Otherwise, WEG can modify motors that were not originally supplied with such protection under request.

**13.4 Forced Ventilation**

For those cases where an independent cooling system is required, W22 motors can be supplied with forced ventilation, as shown in figure 33.

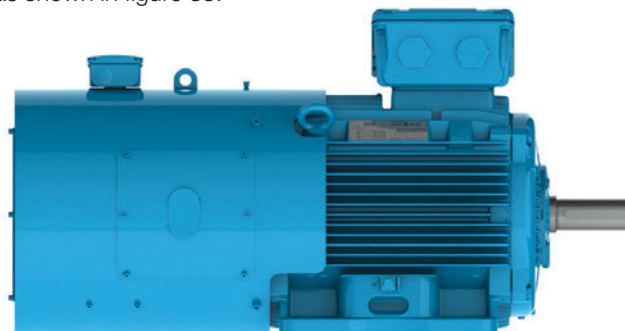

Figure 33 - Forced ventilation for W22 motors

When forced ventilation is assembled on the motor in the factory, the overall motor length will be increased, see Section 21. External Motor Dimensions with Forced Ventilation. As a local stock modification option, an alternative forced ventilation kit can be fitted. Please contact your local WEG office for details of these dimensions.

**13.5 Encoders**

W22 motors may be supplied with encoders for speed control in closed loop. Encoders can be fitted to motors with either forced ventilation(TEBC) or with shaft mounted cooling fan (TEFC). When encoders are fitted, TEFC motors may not have a second shaft end or be fitted with drip cover. The following models of encoder are available for supply:

- Dynapar - B58N - 1024ppr (hollow shaft)- frames 90 to 355
- Leine & Linde - XH861 - 1024ppr (hollow shaft)- frames 160 to 355
- Hengstler - RI58 - 1024ppr (hollow shaft) \*
- Hubner Berlin - HOG 10 - 1024ppr (hollow shaft)\*

\*These models can be supplied on request.

**Note:** The encoders described above have 1024 pulses per revolution. Optionally, models with 2048 pulses per revolution are available.

For more information on VSD motor applications, visit our website ([www.weg.net](http://www.weg.net)) and download the Technical Guide - Induction motors Fed by PWM (code 50029350).

**14. Tolerances for Electrical Data**

The following tolerances are permissible in accordance with IEC 60034-1:

Efficiency (η)	-0,15 (1-η) for Pnom ≤ 150 kW / -0,1 (1-η) for Pnom > 150 kW Where η is a decimal number
Power factor	$\frac{1 - \cos \Phi}{6}$ Minimum 0,02 and Maximum 0,07
Slip	± 20% for Pnom ≥ 1 kW and ± 30 % for Pnom < 1 kW
Starting current	20% (without lower limit)
Starting torque	- 15% + 25%
Breakdown torque	- 10 %
Moment of inertia	± 10 %

Table 21 - Tolerances for electrical data

## 15. Construction Features

Frame		63	71	80	90	100	112	132	160	180			
<b>Mechanical features</b>													
Mounting form		B3T (options are available as per section 6)											
Frame material		FC-200 (EN GJL 200) cast iron											
Degree of protection		IP55											
Grounding		Simple grounding - one earth terminal inside the terminal box											
Cooling method		Totally enclosed fan cooled - IC411											
Fan material		Polypropylene											
		2P											
Fan cover material		Steel							FC-200 (EN GJL 200) cast iron				
Endshields material		FC-200 (EN GJL 200) cast iron											
Drain hole		Rubber drain plug											
Bearings	Drive end side	2p	6201-ZZ	6202-ZZ	6204-ZZ	6205-ZZ	6206-ZZ	6207-ZZ	6308-ZZ	6309-ZZ-C3	6311-ZZ-C3		
		4 - 12p			6203-ZZ	6204-ZZ	6205-ZZ	6206-ZZ	6207-ZZ	6209-ZZ-C3	6211-ZZ-C3		
	Non drive end side	2p											
		4 - 12p											
Locking		Without bearing cap and with spring washer at NDE							Internal bearing cap at DE with spring washer at NDE				
Shaft Seal		V' Ring											
Lubrication	Type of grease	Mobil Polyrex EM											
	Grease fitting	Without grease fitting											
Terminal block		BMC terminal block											
Terminal box material		FC-200 (EN GJL 200) cast iron											
Cable entries	Main	Size	2xM20x1,5			2xM25x1,5		2xM32x1,5		2xM40x1,5			
	Threaded plug		Threaded plug for transport and storage; cable gland as optional										
	Accessory	Size	1xM20x1,5 lateral threaded hole when fitted with accessories										
Shaft	Material		AISI 1040/45										
	DE Threaded hole	2p	M4	M5	M6	M8	M10	M10	M12	M16			
		4 - 12p											
Direction of rotation		Bidirectional											
Vibration level		Grade A											
Nameplate material		Stainless steel AISI 304											
Painting	Type	207 A							203 A				
	Performance Criteria	Corrosive category C2 according to DIN EN ISO 12944-2											
	Colour	IE2 and IE3: RAL 5009 / IE4: RAL 6002											
<b>Electrical features</b>													
Design		N											
Voltage / Frequency		220-240/380-415//460 V (50 // 60Hz)					380-415/660//460 V (50 // 60Hz)						
Winding	Impregnation	Dip and bake											
	Insulation class	F (DT 80K)											
Service factor		1,00											
Rotor		Aluminium die cast											
Thermal protection		Without thermal protection							Thermistor PTC, 1 per phase, for tripping at 155 °C				



Frame	200		225S/M	250S/M	280S/M	315S/M	315L	355M/L	355A/B	
<b>Mechanical features</b>										
Mounting	B3T									
Frame material	FC-200 (EN GJL 200) cast iron									
Degree of protection	IP55									
Grounding	Simple grounding - one earth terminal inside the terminal box			Double grounding - one earth terminal inside the terminal box and another on the motor frame						
Cooling method	Totally enclosed fan cooled - IC411									
Fan material	2p	Polypropylene							Aluminium	
	4-12p	Polypropylene					Aluminium			
Fan cover material	FC-200 (EN GJL 200) cast iron									
Endshields material	FC-200 (EN GJL 200) cast iron									
Drain hole	Rubber drain plug									
Bearings	Drive end side	2p	6312-ZZ-C3	6314-C3	6314-C3	6314-C3	6314-C3	6314-C3	6316-C3	6316-C3
		4 - 12p				6316-C3	6319-C3	6319-C3	6322-C3	6322-C3
	Non drive end side	2p	6212-ZZ-C3	6314-C3	6314-C3	6314-C3	6314-C3	6314-C3	6314-C3	6314-C3
		4 - 12p				6316-C3	6316-C3	6316-C3	6319-C3	6319-C3
	Locking		Internal bearing cap at DE with spring washer at NDE		Locked on drive end with internal and external bearing cap and with preload springs on NDE					
Shaft Seal	V' Ring			WSeal®						
Lubrication	Type of grease		Mobil Polyrex EM*							
	Grease fitting		Without grease fitting			With grease fitting (at DE and NDE)				
Terminal block	BMC terminal block								HGF staggered terminal block	
Terminal box material	FC-200 (EN GJL 200) cast iron									
Cable entries	Main	Size	2xM50x1,5		2xM63x1,5		2xM63x1,5 (removable gland plate)	2xM80x2 (removable gland plate)		
	Threaded plug		Threaded plug for transportation and storage; cable gland as optional							
	Accessory	Size	1xM20x1,5 lateral threaded hole when fitted with accessories							
Shaft	Material		AISI 1040/45				AISI 4140			
	DE Threaded hole	2p	M20					M20		
		4 - 12p						M24		
Direction of rotation	Bidirectional									
Vibration level	Grade A									
Nameplate material	Stainless steel AISI 304									
Painting	Type		203 A							
	Performance Criteria		Corrosive category C2 according to DIN EN ISO 12944-2							
	Colour		IE2 and IE3: RAL 5009 / IE4: RAL 6002							
<b>Electrical features</b>										
Design	N									
Voltage / Frequency	380-415/660//460 V (50 // 60Hz)									
Winding	Impregnation	Dip and bake		Continuous flow impregnation						
	Insulation class	F (DT 80K)								
Service factor	1,00									
Rotor	Aluminium die cast									
Thermal protection	Thermistor PTC, 1 per phase, for tripping at 155 °C									

\* Multi-voltage 50/60Hz motors are provided with Mobil Polyrex EM grease as standard. For spot wound, 2 pole, 60Hz motors in frame sizes 355M/L and 355A/B, Kluber Isoflex NBU 15 will be supplied.

## 16. Optional Features

Frame	63	71	80	90	100	112	132
<b>Mechanical optionals</b>							
<b>Terminal box</b>							
Auxiliary terminal box (thermal protection)	0	0	0	0	0	0	0
Auxiliary terminal box (heaters)	0*	0*	0*	0*	0*	0*	0
Terminal box with removable gland plate	NA	NA	NA	NA	NA	NA	NA
Oversized Terminal Box	0	0	0	0	0	0	0
<b>Terminal block</b>							
BMC terminal block - six-pin	S	S	S	S	S	S	S
BMC terminal block - twelve-pin	NA	NA	NA	0	0	0	0
HGF staggered terminal block	NA	NA	NA	NA	NA	NA	NA
<b>Cable glands</b>							
Plastic cable gland	0	0	0	0	0	0	0
Brass cable gland	0	0	0	0	0	0	0
Stainless steel cable gland	NA	NA	NA	0	0	0	0
<b>Flange</b>							
Flange FF (IEC)	0	0	0	0	0	0	0
Flange FF (IEC) - superior	0	0	0	0	0	0	0
Flange FF (IEC) - inferior	NA	0	0	0	0	0	0
Flange C-DIN (IEC)	0	0	0	0	0	0	0
Flange C-DIN (IEC) - superior	0	0	0	0	0	0	NA
Flange C-DIN (IEC) - inferior	NA	0	0	0	0	NA	0
Flange C (NEMA)	0	0	0	0	0	0	0
Flange C (NEMA) - superior	0	0	0	0	0	NA	0
Flange C (NEMA) - inferior	NA	NA	NA	0	0	0	0
Flange D (NEMA)	0	0	0	0	0	0	0
Flange D (NEMA) - superior	0	0	0	0	0	0	0
Flange D (NEMA) - inferior	NA	0	0	0	0	0	0
<b>Cooling fan</b>							
Polypropylene (2 pole)	S	S	S	S	S	S	S
Polypropylene (4 pole and above)	S	S	S	S	S	S	S
Conductive plastic (2 pole)	0	0	0	0	0	0	0
Conductive plastic (4 pole and above)	0	0	0	0	0	0	0
Aluminium (2 pole)	0	0	0	0	0	0	0
Aluminium (4 pole and above)	0	0	0	0	0	0	0
Cast iron	0	0	0	0	0	0	0
Bronze	0*	0*	0	0	0	0	0
<b>Bearings</b>							
ZZ ball bearings at both ends	S	S	S	S	S	S	S
ZZ-C3 ball bearings at both ends	0	0	0	0	0	0	0
C3 ball bearings at both ends	NA	NA	NA	NA	NA	NA	NA
2RS ball bearings at both ends	0	0	0	0	0	0	0
Without bearing cap at DE	S	S	S	S	S	S	S
With bearing cap at DE	NA	0	0	0	0	0	0
Roller bearing at DE	NA	NA	NA	NA	NA	NA	0
<b>Shaft sealing</b>							
Nitrilic rubber lip seal	0	0	0	0	0	0	0
Nitrilic rubber oil seal	0	0	0	0	0	0	0
Viton lip seal	0	0	0	0	0	0	0
Viton oil seal	0	0	0	0	0	0	0
Taconite labyrinth	NA	NA	NA	0	0	0	0
W3 Seal® (brass)	NA	NA	NA	0	0	0	0
INPRO/SEAL	NA	NA	NA	0	0	0	0
<b>Other sealing</b>							
Joints sealing with Loctite 5923 (permatex)	0	0	0	0	0	0	0
Bolt sealing with Loctite 5923 (permatex)	0	0	0	0	0	0	0
<b>Degree of protection</b>							
IP56	0	0	0	0	0	0	0
IP65	0	0	0	0	0	0	0
IP66	0	0	0	0	0	0	0

Notes: Other optional features, on request. Some combinations of optional features are not possible - please contact WEG.  
 S - Standard      0 - Optional      0\* Optional (feature available upon request for WEG)      NA - Not available

Frame	160	180	200	225S/M	250S/M	280S/M	315S/M	315L	355M/L	355A/B
<b>Mechanical options</b>										
<b>Terminal box</b>										
Auxiliary terminal box (thermal protection)	0	0	0	0	0	0	0	0	0	0
Auxiliary terminal box (heaters)	0	0	0	0	0	0	0	0	0	0
Terminal box with removable gland plate	0 <sup>1</sup>	0 <sup>1</sup>	0 <sup>1</sup>	0	0	0	0	S	S	S
Oversized Terminal Box	NA	NA	NA	0	0	0	0	0	0	NA
<b>Terminal block</b>										
BMC terminal block - six-pin	S	S	S	S	S	S	S	S	S	NA
BMC terminal block - twelve-pin	0	0	0	0	0	0	0	0	0	NA
HGF staggered terminal block	NA	NA	NA	NA	NA	NA	NA	NA	NA	S
<b>Cable glands</b>										
Plastic cable gland	0	0	0	0	0	0	0	0	0	0
Brass cable gland	0	0	0	0	0	0	0	0	0	0
Stainless steel cable gland	0	0	0	0	0	0	0	0	0	0
<b>Flange</b>										
Flange FF (IEC)	0	0	0	0	0	0	0	0	0	0
Flange FF (IEC) - superior	0	0	0	NA	NA	0	NA	NA	NA	NA
Flange FF (IEC) - inferior	0	0	0	0	0	NA	0	0	NA	NA
Flange C-DIN (IEC)	NA	NA	NA	NA	NA	NA	NA	NA	NA	NA
Flange C-DIN (IEC) - superior	NA	NA	NA	NA	NA	NA	NA	NA	NA	NA
Flange C-DIN (IEC) - inferior	0	NA	NA	NA	NA	NA	NA	NA	NA	NA
Flange C (NEMA)	0	0	0	0	0	0	0	0	0	NA
Flange C (NEMA) - superior	NA	0	0	NA	NA	0	NA	NA	NA	NA
Flange C (NEMA) - inferior	NA	NA	NA	NA	0	NA	0	0	NA	NA
Flange D (NEMA)	0	0	0	0	0	0	0	0	0	0
Flange D (NEMA) - superior	0	0	0	NA	NA	0	NA	NA	NA	NA
Flange D (NEMA) - inferior	0	0	0	0	0	NA	0	0	NA	NA
<b>Cooling fan</b>										
Polypropylene (2 pole)	S	S	S	S	S	S	S	S	S	NA
Polypropylene (4 pole and above)	S	S	S	S	S	S	S	NA	NA	NA
Conductive plastic (2 pole)	0	0	0	0	0	0	0	0	0	NA
Conductive plastic (4 pole and above)	0	0	0	0	0	0	0	NA	NA	NA
Aluminium (2 pole)	0	0	0	0	0	0	0	0	0	S
Aluminium (4 pole and above)	0	0	0	0	0	0	0	S	S	S
Cast iron	0	0	0	0	0	0	0	0	0	0
Bronze	0	0	0	0	0	0	0	0	0	0
<b>Bearings</b>										
ZZ ball bearings at both ends	NA	NA	NA	NA	NA	NA	NA	NA	NA	NA
ZZ-C3 ball bearings at both ends	S	S	S	NA	NA	NA	NA	NA	NA	NA
C3 ball bearings at both ends	NA	NA	NA	S	S	S	S	S	S	S
2RS ball bearings at both ends	NA	NA	NA	NA	NA	NA	NA	NA	NA	NA
Without bearing cap at DE	NA	NA	NA	NA	NA	NA	NA	NA	NA	NA
With bearing cap at DE	S	S	S	S	S	S	S	S	S	S
Roller bearing at DE	0	0	0	0	0	0	0	0	0	0
<b>Shaft sealing</b>										
Nitrilic rubber lip seal	0	0	0	0	0	0	NA	NA	NA	NA
Nitrilic rubber oil seal	0	0	0	0	0	0	NA	NA	NA	NA
Viton lip seal	0	0	0	0	0	0	0	0	0	0
Viton oil seal	0	0	0	0	0	0	0	0	0	0
Taconite labyrinth	0	0	0	0	0	0	0	0	0	0
W3 Seal® (brass)	0	0	0	0	0	0	0	0	0	0
INPRO/SEAL	0	0	0	0	0	0	0	0	0	0
<b>Other sealing</b>										
Joints sealing with Loctite 5923 (permatex)	0	0	0	0	0	0	0	0	0	0
Bolt sealing with Loctite 5923 (permatex)	0	0	0	0	0	0	0	0	0	0
<b>Degree of protection</b>										
IP56	0	0	0	0	0	0	0	0	0	0
IP65	0	0	0	0	0	0	0	0	0	0
IP66	0	0	0	0	0	0	0	0	0	0

1) Option available for motors utilizing W21 terminal box.

Frame	63	71	80	90	100	112	132
<b>Shaft</b>							
AISI 1040/45	S	S	S	S	S	S	S
AISI 4140	0	0	0	0	0	0	0
AISI 304 (stainless steel)	0	0	0	0	0	0	0
AISI 316 (stainless steel)	0	0	0	0	0	0	0
AISI 420 (stainless steel)	0	0	0	0	0	0	0
Shaft locking device (standard for roller bearing motors)	NA	NA	NA	NA	NA	NA	0
Second shaft end	0	0	0	0	0	0	0
<b>Painting plan</b>							
202P Primer: One coat with 20 to 55 µm of alkyd red oxide. Intermediate: One coat with 20 to 30 µm of isocyanate epoxy paint. / Finishing: One coat with 70 to 100 µm of polyurethane paint N2677. / Meets atmospheric corrosive category "C4" as indicated in DIN EN ISO 12944-2.	0	0	0	0	0	0	0
211E Primer: One coat with 100 to 140 µm of epoxy paint N2630. / Finishing: One coat with 100 to 140 µm of epoxy paint N2628. / Meets atmospheric corrosive categories C5 (I and M) as indicated in DIN EN ISO 12944-2.	0	0	0	0	0	0	0
211P Primer: One coat with 100 to 140 µm of epoxy paint N2630. / Finishing: One coat with 70 to 100 µm of polyurethane paint N2677. / Meets atmospheric corrosive categories C5 (I and M) as indicated in DIN EN ISO 12944-2.	0	0	0	0	0	0	0
212E Primer: One coat with 75 to 105 µm of epoxy paint N1277. Intermediate: One coat with 100 to 140 µm of epoxy paint N2630. / Finishing: One coat with 100 to 140 µm of epoxy paint N2628. / Meets atmospheric corrosive categories C5 (I and M) as indicated in DIN EN ISO 12944-2.	0	0	0	0	0	0	0
212P Primer: One coat with 75 to 105 µm of epoxy paint N1277. Intermediate: One coat with 100 to 140 µm of epoxy paint N2630. / Finishing: One coat with 70 to 100 µm of polyurethane paint N2677. / Meets atmospheric corrosive categories C5 and CX (I and M) as indicated in DIN EN ISO 12944-2.	0	0	0	0	0	0	0
213E Primer: One coat with 75 to 90 µm of Silicate Ethyl paint N1661. / Intermediate: One coat with 35 to 50 µm of epoxy paint N1202. / Finishing: One coat with 240 to 340 µm of epoxy paint N2628. / Meets atmospheric corrosive categories C5 (I and M) as indicated in DIN EN ISO 12944-2.	0	0	0	0	0	0	0
Inside of terminal box painted	0	0	0	0	0	0	0
Internal tropical protection - complete	0	0	0	0	0	0	0
<b>Grease / Lubrication</b>							
Grease - Aeroshell 7	0*	0*	0*	0*	0*	0*	0*
Grease - Isoflex NBU-15	0	0	0	0	0	0	0
Grease - Aeroshell 22	0	0	0	0	0	0	0
Carbon steel grease nipple	NA	NA	NA	0	0	0	0
Stainless steel grease nipple	NA	NA	NA	0	0	0	0
<b>Balance and Vibration</b>							
Balance without key	0	0	0	0	0	0	0
Balance with full key	0	0	0	0	0	0	0
Vibration level grade B	0	0	0	0	0	0	0
Provision for vibration detector SPM (1 x hole M8 on DE and NDE shield for vertical reading)	NA	NA	NA	0	0	0	0
Key Type A	S	S	S	S	S	S	S
Key Type B	0*	0*	0*	0*	0*	0*	0*
Key Type C	0*	0*	0*	0*	0	0	0
<b>Drain</b>							
Stainless steel threaded drain plug	0	0	0	0	0	0	0
"T" format threaded drain plug	0	0	0	0	0	0	0

Notes: Other optional features, on request.

Some combinations of optional features are not possible - please contact WEG.

S - Standard

O - Optional

O\* Optional (feature available upon request for WEG)

NA - Not available

Frame	160	180	200	225S/M	250S/M	280S/M	315S/M	315L	355M/L	355A/B
<b>Shaft</b>										
AISI 1040/45	S	S	S	S	S	S	S	NA	NA	NA
AISI 4140	0	0	0	0	0	0	0	S	S	S
AISI 304 (stainless steel)	0	0	0	0	0	0	0	0	0	0
AISI 316 (stainless steel)	0	0	0	0	0	0	0	0	0	0
AISI 420 (stainless steel)	0	0	0	0	0	0	0	0	0	0
Shaft locking device (standard for roller bearing motors)	0	0	0	0	0	0	0	0	0	0
Second shaft end	0	0	0	0	0	0	0	0	0	0
<b>Painting plan</b>										
202P Primer: One coat with 20 to 55 µm of alkyd red oxide. Intermediate: One coat with 20 to 30 µm of isocyanate epoxy paint. / Finishing: One coat with 70 to 100 µm of polyurethane paint N2677. / Meets atmospheric corrosive category "C4" as indicated in DIN EN ISO 12944-2.	0	0	0	0	0	0	0	0	0	0
211E Primer: One coat with 100 to 140 µm of epoxy paint N2630. / Finishing: One coat with 100 to 140 µm of epoxy paint N2628. / Meets atmospheric corrosive categories C5 (I and M) as indicated in DIN EN ISO 12944-2.	0	0	0	0	0	0	0	0	0	0
211P Primer: One coat with 100 to 140 µm of epoxy paint N2630. / Finishing: One coat with 70 to 100 µm of polyurethane paint N2677. / Meets atmospheric corrosive categories C5 (I and M) as indicated in DIN EN ISO 12944-2.	0	0	0	0	0	0	0	0	0	0
212E Primer: One coat with 75 to 105 µm of epoxy paint N1277. Intermediate: One coat with 100 to 140 µm of epoxy paint N2630. / Finishing: One coat with 100 to 140 µm of epoxy paint N2628. / Meets atmospheric corrosive categories C5 (I and M) as indicated in DIN EN ISO 12944-2.	0	0	0	0	0	0	0	0	0	0
212P Primer: One coat with 75 to 105 µm of epoxy paint N1277. Intermediate: One coat with 100 to 140 µm of epoxy paint N2630. / Finishing: One coat with 70 to 100 µm of polyurethane paint N2677. / Meets atmospheric corrosive categories C5 and CX (I and M) as indicated in DIN EN ISO 12944-2.	0	0	0	0	0	0	0	0	0	0
213E Primer: One coat with 75 to 90 µm of Silicate Ethyl paint N1661. / Intermediate: One coat with 35 to 50 µm of epoxy paint N1202. / Finishing: One coat with 240 to 340 µm of epoxy paint N2628. / Meets atmospheric corrosive categories C5 (I and M) as indicated in DIN EN ISO 12944-2.	0	0	0	0	0	0	0	0	0	0
Inside of terminal box painted	0	0	0	0	0	0	0	0	0	0
Internal tropical protection - complete	0	0	0	0	0	0	0	0	0	0
<b>Grease / Lubrication</b>										
Grease - Aeroshell 7	0*	0*	0*	0*	0*	0*	0*	0*	0*	0*
Grease - Isoflex NBU-15	0	0	0	0	0	0	0	0	0	0
Grease - Aeroshell 22	0	0	0	0	0	0	0	0	0	0
Carbon steel grease nipple	0	0	0	S	S	S	S	S	S	S
Stainless steel grease nipple	0	0	0	0	0	0	0	0	0	0
<b>Balance and Vibration</b>										
Balance without key	0	0	0	0	0	0	0	0	0	0
Balance with full key	0	0	0	0	0	0	0	0	0	0
Vibration level grade B	0	0	0	0	0	0	0	0	0	0
Provision for vibration detector SPM (1 x hole M8 on DE and NDE shield for vertical reading)	0	0	0	0	0	0	0	0	0	0
Key Type A	S	S	S	0*	0*	0*	0*	0*	0*	0*
Key Type B	0*	0*	0*	S	S	S	S	S	S	S
Key Type C	0	0	0	0	0	0	0	0	0	0
<b>Drain</b>										
Stainless steel threaded drain plug	0	0	0	0	0	0	0	0	0	0
"T" format threaded drain plug	0	0	0	0	0	0	0	0	0	0

Frame	63	71	80	90	100	112	132
<b>Grounding</b>							
Double grounding (one inside terminal box and another on the motor frame)	0	0	0	0	0	0	0
Triple grounding (one inside terminal box, two on the motor frame)	NA	NA	0	0	0	0	0
<b>Nameplates</b>							
Second main nameplate (loose)	0	0	0	0	0	0	0
Additional / Tag plate	0	0	0	0	0	0	0
VSD rating plate	0	0	0	0	0	0	0
Direction of Rotation plate	0	0	0	0	0	0	0
<b>Other mechanical options</b>							
Drip cover (recommended for vertical shaft down applications)	0	0	0	0	0	0	0
Rubber slinger (recommended for vertical shaft up applications)	NA	NA	NA	0	0	0	0
Stainless steel hardware	0	0	0	0	0	0	0
Grease outlet through the endshield	NA	NA	NA	0*	0*	0*	0*
Without cooling fan - IC 418 (TEAO) or IC 410 (TENV)	0*	0*	0*	0*	0*	0*	0*
Loose leads in lieu of t/box (up to 2 metres)	0	0	0	0	0	0	0
<b>Electrical options</b>							
<b>Winding thermal protection</b>							
Thermostat - alarm / trip (NO or NC) - 130 °C	0	0	0	0	0	0	0
Thermostat - alarm / trip (NO or NC) - 155 °C	0	0	0	0	0	0	0
Thermostat - trip (NO or NC) - 180 °C	0	0	0	0	0	0	0
Pt-100 two wires, one per phase	0	0	0	0	0	0	0
Pt-100 two wires, two per phase	0	0	0	0	0	0	0
Pt-100 three wires, one per phase	0	0	0	0	0	0	0
Pt-100 three wires, two per phase	0	0	0	0	0	0	0
PTC Thermistor - alarm/trip (130 °C)	0	0	0	0	0	0	0
PTC Thermistor - alarm/trip (155 °C)	0	0	0	0	0	0	0
PTC Thermistor - trip (180 °C)	0	0	0	0	0	0	0
<b>Bearing thermal protection</b>							
Thermostat, one per bearing	NA	NA	NA	0*	0*	0*	0*
PTC Thermistor, one per bearing	NA	NA	NA	0*	0*	0*	0*
Pt-100 two wires, one per bearing	NA	NA	NA	0*	0*	0*	0*
Pt-100 three wires, one per bearing	NA	NA	NA	0*	0*	0*	0*
Pt-100 three wires (calibrated)	NA	NA	NA	0*	0*	0*	0*
<b>Space heaters</b>							
110-127 V	0	0	0	0	0	0	0
220-240 V	0	0	0	0	0	0	0
110-127 / 220-240 V	0	0	0	0	0	0	0
380-480 V	0	0	0	0	0	0	0
<b>Service factor</b>							
Service factor 1,15	0	0	0	0	0	0	0
<b>Insulation class</b>							
H	0	0	0	0	0	0	0
<b>Variable Speed Options</b>							
Forced ventilation kit with encoder provision (inform auxiliary motor voltage)	NA	NA	NA	0	0	0	0
Forced ventilation kit without encoder provision (inform auxiliary motor voltage)	NA	NA	NA	0	0	0	0
Encoder	NA	NA	NA	0	0	0	0
DE side shaft grounding brush	NA	NA	NA	NA	NA	NA	NA
NDE side shaft grounding brush	NA	NA	NA	NA	NA	NA	NA
Insulated DE ball bearing	NA	NA	NA	NA	NA	NA	NA
Insulated NDE ball bearing	NA	NA	NA	NA	NA	NA	NA
Insulated DE bearing hub	NA	NA	NA	NA	NA	NA	NA
Insulated NDE bearing hub	NA	NA	NA	NA	NA	NA	NA

Notes: Other optional features, on request.

Some combinations of optional features are not possible - please contact WEG.

S - Standard

O - Optional

O\* Optional (feature available upon request for WEG)

NA - Not available

Frame	160	180	200	225S/M	250S/M	280S/M	315S/M	315L	355M/L	355A/B
<b>Grounding</b>										
Double grounding (one inside terminal box and another on the motor frame)	0	0	0	S	S	S	S	S	S	S
Triple grounding (one inside terminal box, two on the motor frame)	0	0	0	0	0	0	0	0	0	0
<b>Nameplates</b>										
Second main nameplate (loose)	0	0	0	0	0	0	0	0	0	0
Additional / Tag plate	0	0	0	0	0	0	0	0	0	0
VSD rating plate	0	0	0	0	0	0	0	0	0	0
Direction of Rotation plate	0	0	0	0	0	0	0	0	0	0
<b>Other mechanical options</b>										
Drip cover (recommended for vertical shaft down applications)	0	0	0	0	0	0	0	0	0	0
Rubber slinger (recommended for vertical shaft up applications)	0	0	0	0	0	0	0	0	0	0
Stainless steel hardware	0	0	0	0	0	0	0	0	0	0
Grease outlet through the endshield	0*	0*	0*	0	0	0	0	0	0	0
Without cooling fan - IC 418 (TEAO) or IC 410 (TENV)	0*	0*	0*	0*	0*	0*	0*	0*	0*	0*
Loose leads in lieu of t/box (up to 2 metres)	0	0	0	0	0	0	0	0	0	0
<b>Electrical options</b>										
<b>Winding thermal protection</b>										
Thermostat - alarm / trip (NO or NC) - 130 °C	0	0	0	0	0	0	0	0	0	0
Thermostat - alarm / trip (NO or NC) - 155 °C	0	0	0	0	0	0	0	0	0	0
Thermostat - trip (NO or NC) - 180 °C	0	0	0	0	0	0	0	0	0	0
Pt-100 two wires, one per phase	0	0	0	0	0	0	0	0	0	0
Pt-100 two wires, two per phase	0	0	0	0	0	0	0	0	0	0
Pt-100 three wires, one per phase	0	0	0	0	0	0	0	0	0	0
Pt-100 three wires, two per phase	0	0	0	0	0	0	0	0	0	0
PTC Thermistor - alarm/trip (130 °C)	0	0	0	0	0	0	0	0	0	0
PTC Thermistor - alarm/trip (155 °C)	S	S	S	S	S	S	S	S	S	S
PTC Thermistor - trip (180 °C)	0	0	0	0	0	0	0	0	0	0
<b>Bearing thermal protection</b>										
Thermostat	0	0	0	0	0	0	0	0	0	0
PTC Thermistor	0	0	0	0	0	0	0	0	0	0
Pt-100 two wires, one per bearing	0	0	0	0	0	0	0	0	0	0
Pt-100 three wires, one per bearing	0	0	0	0	0	0	0	0	0	0
Pt-100 three wires (calibrated)	0	0	0	0	0	0	0	0	0	0
<b>Space heaters</b>										
110-127 V	0	0	0	0	0	0	0	0	0	0
220-240 V	0	0	0	0	0	0	0	0	0	0
110-127 / 220-240 V	0	0	0	0	0	0	0	0	0	0
380-480 V	0	0	0	0	0	0	0	0	0	0
<b>Service factor</b>										
Service factor 1,15	0	0	0	0	0	0	0	0	0	0
<b>Insulation class</b>										
H	0	0	0	0	0	0	0	0	0	0
<b>Variable Speed Options</b>										
Forced ventilation kit with encoder provision (inform auxiliary motor voltage)	0	0	0	0	0	0	0	0	0	0
Forced ventilation kit without encoder provision (inform auxiliary motor voltage)	0	0	0	0	0	0	0	0	0	0
Encoder	0	0	0	0	0	0	0	0	0	0
DE side shaft grounding brush	NA	NA	NA	0*	0*	0*	0	0	0	0
NDE side shaft grounding brush	NA	NA	NA	0	0	0	0	0	0	0
Insulated DE ball bearing	NA	NA	NA	0	0	0	0	0	0	0
Insulated NDE ball bearing	NA	NA	NA	0	0	0	0	0	0	0
Insulated DE bearing hub	NA	NA	NA	0	0	0	0	0	0	0
Insulated NDE bearing hub	NA	NA	NA	0	0	0	S	S	S	S

# 17. Electrical Data

## W22 - Premium Efficiency - IE3 <sup>(1)</sup>

Output		Frame	Full Load Torque (Nm)	Locked Rotor Current I <sub>L</sub> /I <sub>n</sub>	Locked Rotor Torque T <sub>L</sub> /T <sub>n</sub>	Break-down Torque T <sub>b</sub> /T <sub>n</sub>	Inertia J (kgm <sup>2</sup> )	Allowable locked rotor time (s)		Weight (kg)	Sound dB(A)	400 V								
								Rated speed (rpm)	% of full load			Full load current I <sub>n</sub> (A)								
									Efficiency			Power Factor								
kW	HP							Hot	Cold			50	75	100	50	75	100			
II pole - 3000 rpm - 50 Hz																				
0,12	0,16	63	0,410	5,4	3,1	3,3	0,0001	30	66	6,9	52,0	2820	58,0	60,8	60,8	0,54	0,67	0,76	0,375	
0,18	0,25	63	0,600	5,2	3,0	3,2	0,0002	22	48	8,1	52,0	2860	61,0	65,9	65,9	0,53	0,65	0,74	0,533	
0,25	0,33	63	0,850	5,5	3,2	3,2	0,0002	17	37	7,9	52,0	2805	63,0	68,0	69,7	0,54	0,68	0,77	0,672	
0,37	0,5	71	1,25	6,0	2,5	2,5	0,0004	12	26	10,6	56,0	2820	73,0	73,8	73,8	0,66	0,79	0,85	0,851	
0,55	0,75	71	1,90	5,9	3,0	3,0	0,0005	18	40	10,9	56,0	2770	75,0	76,0	77,8	0,68	0,81	0,86	1,19	
0,75	1	80	2,51	7,5	3,9	3,5	0,0008	25	55	13,9	59,0	2850	80,0	82,0	81,0	0,63	0,75	0,82	1,63	
1,1	1,5	80	3,71	7,4	3,6	3,6	0,0009	23	51	14,8	59,0	2830	81,0	83,5	83,0	0,63	0,76	0,82	2,33	
1,5	2	90S	4,99	7,6	3,3	3,3	0,0020	15	33	20,6	62,0	2875	83,0	85,0	84,5	0,64	0,76	0,83	3,09	
2,2	3	90L	7,34	7,5	3,1	3,4	0,0026	12	26	24,9	62,0	2865	85,5	86,0	86,3	0,65	0,77	0,83	4,43	
3	4	100L	9,85	8,5	3,4	3,4	0,0064	15	33	33,0	67,0	2910	85,5	87,3	87,3	0,69	0,81	0,86	5,77	
4	5,5	112M	13,2	7,7	2,5	3,5	0,0081	14	31	42,3	64,0	2900	88,0	88,4	88,4	0,69	0,80	0,86	7,59	
5,5	7,5	132S	17,9	7,9	2,4	3,5	0,0180	12	26	61,3	67,0	2940	86,9	88,7	89,4	0,66	0,78	0,84	10,6	
7,5	10	132S	24,4	8,5	3,0	3,6	0,0234	10	22	68,8	67,0	2935	88,5	89,8	90,3	0,68	0,80	0,85	14,1	
9,2	12,5	132M	30,0	8,5	2,8	3,1	0,0303	16	35	83,5	67,0	2935	90,4	91,1	90,7	0,75	0,84	0,88	16,6	
11	15	160M	35,6	8,0	2,8	3,4	0,0482	12	26	113	67,0	2950	90,3	91,4	91,4	0,71	0,82	0,87	20,0	
15	20	160M	48,7	8,3	2,8	3,5	0,0551	8	18	120	67,0	2945	90,9	91,8	92,1	0,67	0,79	0,85	27,7	
18,5	25	160L	60,0	8,6	3,1	3,7	0,0663	6	13	135	67,0	2945	91,5	92,3	92,6	0,69	0,80	0,85	33,9	
22	30	180M	71,3	8,3	2,7	3,6	0,0968	6	13	168	67,0	2950	92,3	93,0	92,9	0,69	0,80	0,86	39,7	
30	40	200L	96,7	7,7	3,0	3,0	0,1703	16	35	232	72,0	2965	92,2	93,2	93,5	0,69	0,80	0,85	54,5	
37	50	200L	119	7,7	3,1	3,0	0,1881	13	29	248	72,0	2960	92,6	93,4	93,8	0,69	0,79	0,84	67,8	
45	60	225S/M	145	7,7	2,4	3,1	0,2861	13	29	381	74,0	2960	94,2	94,5	94,2	0,78	0,86	0,89	77,5	
55	75	250S/M	177	8,0	2,8	3,3	0,3736	19	42	452	74,0	2965	93,5	94,0	94,4	0,77	0,84	0,87	96,7	
75	100	280S/M	241	7,5	2,0	3,1	0,9386	36	79	674	77,0	2975	93,7	94,8	94,9	0,78	0,85	0,88	130	
90	125	280S/M	289	7,6	2,1	2,9	1,12	27	59	700	77,0	2976	94,3	95,2	95,2	0,81	0,87	0,89	153	
110	150	315S/M	353	7,5	1,9	3,0	1,66	38	84	913	77,0	2980	94,3	95,3	95,4	0,78	0,85	0,88	189	
132	175	315S/M	423	7,6	2,1	3,1	1,96	34	75	988	77,0	2980	94,5	95,4	95,6	0,78	0,86	0,89	224	
150	200	315S/M	481	7,5	2,3	3,0	2,18	20	44	1050	77,0	2979	95,0	95,6	95,6	0,80	0,86	0,89	254	
160	220	315S/M	513	7,4	2,0	2,9	2,24	28	62	1056	77,0	2980	95,1	95,8	95,8	0,79	0,86	0,89	271	
185	250	315S/M	593	7,6	2,3	3,1	2,46	22	48	1110	77,0	2980	95,4	95,8	95,8	0,79	0,86	0,89	313	
200	270	315L	642	7,6	2,3	2,9	2,68	23	51	1230	78,0	2975	95,7	96,2	96,0	0,82	0,88	0,90	334	
220	300	315L	705	8,5	2,7	3,3	3,13	23	51	1320	78,0	2980	95,9	96,0	96,0	0,81	0,88	0,90	368	
250	340	315L	802	7,8	2,7	2,9	3,57	21	46	1304	78,0	2980	96,3	96,0	96,0	0,85	0,90	0,91	413	
260	350	315L	834	7,8	2,7	2,9	3,57	21	46	1370	78,0	2980	96,3	96,7	96,0	0,85	0,90	0,91	430	
280	380	315L	898	7,5	2,5	2,7	4,17	22	48	1550	78,0	2980	95,4	95,8	96,0	0,84	0,89	0,91	463	
315	430	355M/L <sup>(4)</sup>	1009	7,7	2,6	2,7	6,01	23	51	1936	80,0	2983	95,5	96,0	96,0	0,87	0,90	0,91	520	
330	450	355M/L	1058	7,7	2,3	2,5	6,01	28	62	1950	80,0	2980	95,2	95,8	96,0	0,87	0,90	0,91	545	
355	480	355M/L <sup>(4)</sup>	1135	9,5	2,6	3,2	6,01	14	31	1925	80,0	2988	95,3	95,6	95,8	0,82	0,88	0,90	594	
370	500	355A/B <sup>(4)</sup>	1184	7,9	2,5	2,8	6,76	40	88	2046	83,0	2985	95,8	96,1	96,4	0,85	0,89	0,90	616	
400	550	355A/B <sup>(4)</sup>	1281	8,2	2,7	2,9	6,76	31	68	2250	83,0	2984	95,8	96,2	96,4	0,85	0,89	0,91	658	
450	610	355A/B <sup>(4)</sup>	1442	7,5	2,8	2,7	7,40	31	68	2400	83,0	2982	95,8	96,2	96,4	0,85	0,90	0,91	740	
II pole - 3000 rpm - 50 Hz - Optional frames & high output designs																				
11	15	132M	35,9	8,2	2,7	3,0	0,0303	11	24	84,0	67,0	2925	90,6	91,1	91,2	0,75	0,85	0,89	19,6	
75	100	250S/M	242	8,5	3,0	3,2	0,5132	11	24	500	74,0	2965	94,0	94,6	94,9	0,82	0,87	0,89	128	
110	150	280S/M	353	7,5	2,1	3,0	1,33	20	44	790	77,0	2975	95,0	95,5	95,4	0,80	0,87	0,89	187	

Note:  
 (1) Efficiency values are given according to IEC 60034-2-1. They are calculated according to indirect method, with stray load losses determined by measurement.  
 (4) Fitted with air deflector in the drive end side.



**W22 - Premium Efficiency - IE3 <sup>(1)</sup>**

Output		380 V									415 V								
		Rated speed (rpm)	% of full load						Full load current In (A)	Rated speed (rpm)	% of full load						Full load current In (A)		
			Efficiency			Power Factor					Efficiency			Power Factor					
kW	HP		50	75	100	50	75	100			50	75	100	50	75	100			
II pole - 3000 rpm - 50 Hz																			
0,12	0,16	2795	59,0	60,8	60,8	0,58	0,71	0,79	0,380	2835	57,0	60,8	60,8	0,51	0,64	0,73	0,376		
0,18	0,25	2835	62,6	65,9	65,9	0,57	0,70	0,79	0,525	2870	59,6	65,2	65,9	0,49	0,62	0,71	0,535		
0,25	0,33	2780	64,6	68,7	69,7	0,59	0,73	0,81	0,673	2820	61,5	67,2	69,7	0,51	0,64	0,74	0,674		
0,37	0,5	2795	73,6	74,3	73,8	0,71	0,82	0,87	0,876	2825	72,4	73,8	73,8	0,63	0,76	0,83	0,840		
0,55	0,75	2740	75,6	75,7	77,8	0,73	0,84	0,88	1,22	2790	74,4	76,0	77,8	0,65	0,78	0,84	1,17		
0,75	1	2830	80,0	80,5	80,7	0,68	0,78	0,85	1,66	2860	79,1	81,0	81,1	0,59	0,72	0,79	1,63		
1,1	1,5	2810	82,0	83,7	83,1	0,69	0,80	0,85	2,37	2840	80,0	83,0	83,4	0,58	0,72	0,79	2,32		
1,5	2	2860	83,7	85,0	84,4	0,69	0,80	0,85	3,18	2885	82,2	84,8	85,2	0,59	0,72	0,80	3,06		
2,2	3	2840	85,0	85,5	85,9	0,70	0,81	0,86	4,52	2875	85,3	86,4	86,5	0,61	0,74	0,81	4,37		
3	4	2900	86,0	87,4	87,1	0,75	0,84	0,88	5,95	2915	85,0	87,2	87,4	0,66	0,78	0,84	5,68		
4	5,5	2890	88,0	88,2	88,2	0,73	0,83	0,88	7,83	2910	87,5	88,0	88,4	0,65	0,77	0,84	7,49		
5,5	7,5	2935	87,6	88,9	89,2	0,71	0,82	0,87	10,8	2945	86,1	88,3	89,2	0,61	0,74	0,81	10,6		
7,5	10	2925	89,2	90,1	90,1	0,73	0,83	0,88	14,4	2940	87,9	89,7	90,3	0,63	0,76	0,83	13,9		
9,2	12,5	2925	90,7	91,0	90,8	0,79	0,87	0,90	17,1	2940	90,1	91,0	91,3	0,71	0,82	0,87	16,1		
11	15	2945	90,7	91,2	91,2	0,75	0,84	0,88	20,8	2950	89,9	91,3	91,4	0,68	0,79	0,85	19,7		
15	20	2940	91,0	91,6	91,9	0,72	0,82	0,87	28,5	2950	90,3	91,6	91,9	0,63	0,76	0,82	27,7		
18,5	25	2945	92,0	92,3	92,4	0,74	0,83	0,88	34,6	2950	91,0	92,2	92,4	0,64	0,77	0,83	33,6		
22	30	2945	92,4	92,7	92,7	0,74	0,83	0,87	41,4	2955	92,0	92,8	92,7	0,66	0,78	0,84	39,3		
30	40	2960	92,6	93,2	93,3	0,75	0,83	0,87	56,2	2970	91,8	93,0	93,3	0,64	0,76	0,82	54,6		
37	50	2960	93,0	93,6	93,7	0,75	0,84	0,87	69,0	2965	92,0	93,2	93,7	0,63	0,76	0,82	67,0		
45	60	2960	93,8	94,0	94,0	0,81	0,88	0,90	80,8	2965	94,0	94,0	94,3	0,75	0,84	0,88	75,4		
55	75	2960	93,5	94,0	94,3	0,80	0,86	0,88	101	2965	93,4	94,0	94,4	0,73	0,82	0,86	94,3		
75	100	2975	93,9	94,7	94,7	0,81	0,87	0,89	135	2980	93,5	94,7	94,9	0,76	0,84	0,87	126		
90	125	2973	94,5	95,0	95,0	0,83	0,88	0,89	162	2978	94,2	95,2	95,2	0,78	0,86	0,88	149		
110	150	2975	94,6	95,4	95,4	0,81	0,87	0,89	197	2980	94,1	95,2	95,4	0,75	0,84	0,87	184		
132	175	2975	94,7	95,5	95,6	0,81	0,87	0,90	233	2980	94,3	95,4	95,6	0,75	0,84	0,88	218		
150	200	2976	95,0	95,6	95,6	0,83	0,88	0,90	265	2981	94,3	95,3	95,6	0,78	0,85	0,89	245		
160	220	2980	95,3	95,8	95,8	0,82	0,88	0,90	282	2980	94,9	95,8	95,8	0,77	0,85	0,88	264		
185	250	2975	95,5	95,8	95,8	0,82	0,88	0,90	326	2980	95,2	95,8	95,8	0,77	0,85	0,88	305		
200	270	2975	95,8	96,2	96,0	0,84	0,89	0,91	348	2980	95,6	96,2	96,0	0,80	0,87	0,89	326		
220	300	2980	96,0	96,0	96,0	0,83	0,89	0,91	383	2980	95,8	96,0	96,0	0,79	0,86	0,89	358		
250	340	2975	96,4	96,0	96,0	0,87	0,91	0,92	430	2980	96,3	96,0	96,0	0,83	0,89	0,91	398		
260	350	2975	96,4	96,0	96,0	0,87	0,91	0,92	447	2980	96,3	96,0	96,0	0,83	0,89	0,91	414		
280	380	2975	96,2	95,8	96,0	0,87	0,91	0,91	487	2980	96,2	95,8	96,0	0,85	0,89	0,90	451		
315	430	2980	95,0	96,0	96,0	0,89	0,91	0,91	548	2984	95,2	95,6	95,8	0,86	0,90	0,91	503		
330	450	2980	95,2	96,0	96,0	0,90	0,91	0,91	574	2985	95,6	96,2	96,2	0,88	0,91	0,92	519		
355	480	2987	95,3	95,5	95,8	0,84	0,89	0,90	626	2989	95,3	95,6	95,8	0,80	0,86	0,89	579		
370	500	2980	95,8	96,0	96,2	0,86	0,90	0,91	642	2985	95,5	96,3	96,4	0,84	0,88	0,89	600		
400	550	2982	95,9	96,2	96,3	0,87	0,90	0,91	694	2986	95,7	96,2	96,4	0,84	0,88	0,91	634		
450	610	2979	95,9	96,2	96,4	0,87	0,91	0,91	779	2983	95,7	96,2	96,4	0,84	0,89	0,91	714		
II pole - 3000 rpm - 50 Hz - Optional frames & high output designs																			
11	15	2915	90,9	91,0	91,2	0,80	0,87	0,90	20,4	2930	90,2	91,1	91,4	0,72	0,82	0,87	19,2		
75	100	2960	94,0	94,5	94,7	0,84	0,88	0,90	134	2965	94,0	94,7	94,9	0,80	0,86	0,88	125		
110	150	2975	95,0	95,2	95,2	0,84	0,89	0,91	193	2980	94,9	95,4	95,4	0,80	0,87	0,90	178		



**W22 - Premium Efficiency - IE3 <sup>(1)</sup>**

Output		380 V									415 V								
		Rated speed (rpm)	% of full load						Full load current In (A)	Rated speed (rpm)	% of full load						Full load current In (A)		
			Efficiency			Power Factor					Efficiency			Power Factor					
kW	HP		50	75	100	50	75	100		50	75	100	50	75	100				
IV pole - 1500 rpm - 50 Hz																			
0,12	0,16	1355	58,6	64,0	64,8	0,56	0,69	0,76	0,370	1380	55,6	63,0	64,8	0,50	0,62	0,72	0,358		
0,18	0,25	1355	65,0	67,0	69,9	0,57	0,67	0,75	0,522	1380	65,0	67,0	69,9	0,50	0,61	0,70	0,512		
0,25	0,33	1400	67,0	69,1	73,5	0,56	0,67	0,75	0,689	1420	65,1	68,6	73,5	0,50	0,62	0,69	0,686		
0,37	0,5	1370	73,0	75,0	77,3	0,53	0,64	0,72	1,01	1395	73,0	75,0	77,3	0,47	0,59	0,68	0,979		
0,55	0,75	1410	78,0	79,1	80,8	0,65	0,77	0,83	1,25	1430	76,0	78,9	80,8	0,57	0,71	0,77	1,23		
0,75	1	1425	79,0	81,5	82,5	0,59	0,73	0,82	1,68	1435	77,0	81,0	82,5	0,50	0,65	0,76	1,66		
1,1	1,5	1445	84,0	84,7	84,3	0,64	0,76	0,83	2,39	1455	82,0	84,1	84,8	0,55	0,69	0,77	2,34		
1,5	2	1440	85,0	86,2	85,6	0,63	0,76	0,83	3,21	1450	83,1	85,7	86,1	0,54	0,68	0,77	3,15		
2,2	3	1430	87,2	87,1	86,7	0,65	0,77	0,83	4,64	1440	85,7	86,8	87,2	0,57	0,70	0,78	4,50		
3	4	1430	87,7	88,0	87,7	0,65	0,77	0,83	6,26	1445	86,3	87,7	88,1	0,56	0,70	0,78	6,07		
4	5,5	1445	89,3	89,0	88,6	0,65	0,76	0,81	8,47	1455	88,2	88,9	89,3	0,57	0,70	0,77	8,09		
5,5	7,5	1460	89,0	89,6	89,6	0,73	0,83	0,87	10,7	1465	89,4	89,6	89,8	0,65	0,78	0,84	10,1		
7,5	10	1460	90,0	90,2	90,4	0,66	0,79	0,86	14,7	1465	89,2	90,3	90,4	0,60	0,73	0,83	13,9		
9,2	12,5	1460	91,0	91,1	91,0	0,69	0,80	0,85	17,7	1470	89,5	90,6	91,0	0,60	0,73	0,80	17,2		
11	15	1470	91,7	91,4	91,4	0,69	0,80	0,85	21,5	1475	90,6	91,4	91,5	0,61	0,74	0,81	20,6		
15	20	1465	92,4	92,4	92,1	0,70	0,80	0,85	29,1	1470	91,6	92,3	92,1	0,62	0,75	0,81	28,0		
18,5	25	1470	92,7	92,6	92,6	0,69	0,79	0,84	36,1	1475	91,8	92,6	92,6	0,61	0,73	0,80	34,7		
22	30	1470	92,5	92,8	93,0	0,70	0,81	0,85	42,3	1475	91,9	92,8	93,0	0,62	0,74	0,81	40,6		
30	40	1475	93,4	93,6	93,6	0,68	0,79	0,84	58,0	1480	92,3	93,3	93,6	0,59	0,72	0,79	56,4		
37	50	1480	93,7	93,9	93,9	0,74	0,83	0,86	69,6	1480	93,1	93,9	93,9	0,66	0,78	0,83	66,0		
45	60	1475	93,8	94,0	94,2	0,75	0,83	0,87	83,4	1480	93,5	94,1	94,4	0,68	0,79	0,84	79,0		
55	75	1480	94,5	94,6	94,7	0,73	0,82	0,86	103	1480	94,0	94,6	94,6	0,66	0,78	0,83	97,5		
75	100	1480	94,7	94,9	95,0	0,75	0,83	0,86	139	1485	94,4	94,9	95,2	0,70	0,79	0,84	130		
90	125	1480	95,2	95,4	95,2	0,77	0,84	0,87	165	1485	95,0	95,4	95,4	0,72	0,81	0,85	154		
110	150	1490	95,0	95,5	95,5	0,78	0,85	0,87	201	1490	94,4	95,4	95,5	0,71	0,81	0,85	189		
132	175	1490	95,3	95,6	95,6	0,77	0,84	0,87	241	1490	94,8	95,6	95,6	0,71	0,81	0,85	226		
150	200	1490	95,4	95,8	95,9	0,76	0,84	0,87	273	1490	95,4	95,9	96,0	0,69	0,79	0,84	259		
160	220	1490	95,7	95,8	95,8	0,77	0,84	0,87	292	1490	95,3	95,8	95,8	0,71	0,81	0,85	273		
185	250	1490	95,8	96,0	96,0	0,75	0,83	0,86	340	1490	95,2	96,0	96,0	0,68	0,78	0,83	323		
200	270	1485	96,1	96,2	96,0	0,80	0,86	0,88	360	1490	95,9	96,3	96,1	0,76	0,83	0,87	333		
220	300	1490	96,0	96,4	96,3	0,75	0,83	0,87	399	1490	95,5	96,2	96,2	0,69	0,79	0,84	379		
250	340	1490	95,8	96,0	96,2	0,77	0,84	0,87	454	1490	96,0	96,2	96,4	0,71	0,80	0,85	424		
260	350	1490	95,8	96,0	96,2	0,77	0,84	0,87	472	1490	96,0	96,2	96,4	0,71	0,80	0,85	441		
280	380	1490	95,8	96,0	96,0	0,79	0,86	0,88	504	1490	95,8	96,0	96,0	0,74	0,83	0,86	472		
300	400	1489	95,8	96,1	96,0	0,77	0,84	0,87	546	1490	95,2	95,9	96,0	0,70	0,80	0,85	511		
315	430	1490	95,8	96,0	96,0	0,75	0,83	0,86	580	1492	95,9	96,0	96,0	0,68	0,79	0,84	543		
330	450	1490	95,8	96,2	96,2	0,80	0,86	0,88	592	1490	95,8	96,2	96,2	0,75	0,83	0,87	549		
355	480	1490	96,0	96,4	96,4	0,77	0,85	0,87	643	1490	95,8	96,3	96,4	0,72	0,82	0,85	603		
400	550	1490	96,0	96,2	96,1	0,72	0,82	0,86	735	1490	95,4	95,9	96,1	0,65	0,76	0,82	706		
450	610	1490	96,0	96,2	96,2	0,73	0,83	0,86	826	1490	95,5	95,9	96,1	0,65	0,77	0,82	794		
500	680	1490	96,1	96,3	96,3	0,76	0,84	0,87	907	1490	95,7	96,2	96,3	0,69	0,79	0,84	860		
IV pole - 1500 rpm - 50 Hz - Optional frames & high output designs																			
37	50	1475	92,9	93,4	93,9	0,69	0,79	0,84	71,3	1480	93,0	93,5	94,0	0,60	0,73	0,80	68,5		
75	100	1480	94,5	94,8	95,0	0,77	0,86	0,88	136	1480	94,7	95,0	95,2	0,70	0,81	0,86	127		
110	150	1480	95,4	95,4	95,4	0,77	0,84	0,87	201	1485	95,2	95,6	95,6	0,71	0,81	0,85	188		
200	270	1485	95,8	96,0	96,0	0,80	0,86	0,88	360	1490	95,9	96,0	96,1	0,76	0,83	0,87	333		



**W22 - Premium Efficiency - IE3 <sup>(1)</sup>**

Output		380 V									415 V								
		Rated speed (rpm)	% of full load						Full load current In (A)	Rated speed (rpm)	% of full load						Full load current In (A)		
			Efficiency			Power Factor					Efficiency			Power Factor					
kW	HP		50	75	100	50	75	100			50	75	100	50	75	100			
VI pole - 1000 rpm - 50 Hz																			
0,12	0,16	910	48,7	54,7	57,7	0,40	0,53	0,63	0,502	930	50,0	55,0	57,7	0,39	0,47	0,56	0,517		
0,18	0,25	885	57,7	62,8	63,9	0,43	0,55	0,64	0,669	910	54,5	61,2	63,9	0,38	0,48	0,57	0,688		
0,25	0,33	950	65,9	68,0	68,6	0,51	0,64	0,74	0,748	960	61,7	68,2	68,8	0,45	0,57	0,68	0,743		
0,37	0,5	915	67,6	69,9	73,5	0,55	0,69	0,79	0,968	930	64,3	68,8	73,5	0,48	0,62	0,72	0,973		
0,55	0,75	940	73,4	76,7	77,2	0,49	0,63	0,73	1,48	950	67,9	75,0	77,2	0,42	0,55	0,65	1,52		
0,75	1	945	77,5	79,2	78,9	0,53	0,66	0,74	1,95	955	75,3	78,6	79,1	0,46	0,59	0,69	1,91		
1,1	1,5	940	81,0	82,0	81,0	0,55	0,69	0,77	2,68	950	77,7	80,7	81,0	0,47	0,61	0,70	2,70		
1,5	2	950	82,3	82,6	82,5	0,53	0,66	0,74	3,73	960	80,6	82,3	82,8	0,46	0,59	0,68	3,71		
2,2	3	955	83,6	84,4	84,3	0,57	0,68	0,75	5,29	965	82,3	84,3	84,7	0,50	0,62	0,70	5,16		
3	4	965	85,0	85,8	85,8	0,57	0,69	0,76	6,99	975	85,2	85,8	86,0	0,49	0,63	0,71	6,84		
4	5,5	960	86,3	86,8	86,8	0,57	0,70	0,76	9,21	970	85,4	86,5	86,8	0,49	0,62	0,71	9,03		
5,5	7,5	965	87,4	88,3	88,0	0,55	0,68	0,75	12,7	975	85,8	87,7	88,0	0,47	0,60	0,67	13,0		
7,5	10	970	88,9	89,0	89,1	0,68	0,79	0,84	15,2	980	88,0	89,0	89,1	0,61	0,73	0,80	14,6		
9,2	12,5	970	89,5	90,0	90,0	0,68	0,78	0,83	18,7	975	89,6	90,0	90,0	0,61	0,73	0,79	18,0		
11	15	975	89,7	90,3	90,3	0,65	0,77	0,82	22,6	980	88,3	89,8	90,5	0,57	0,70	0,78	21,7		
15	20	975	90,7	91,0	91,2	0,68	0,80	0,86	29,1	980	91,3	91,6	91,6	0,62	0,75	0,82	27,8		
18,5	25	980	91,0	91,7	91,7	0,68	0,78	0,83	36,9	985	90,3	91,4	91,7	0,59	0,72	0,78	36,0		
22	30	980	92,0	92,2	92,2	0,69	0,79	0,84	43,2	980	90,8	91,8	92,2	0,60	0,72	0,79	42,0		
30	40	980	93,3	93,3	92,9	0,71	0,80	0,85	57,7	985	92,8	93,4	93,0	0,64	0,75	0,82	54,7		
37	50	980	93,3	93,3	93,3	0,75	0,83	0,87	69,3	985	93,3	93,5	93,5	0,69	0,80	0,84	65,5		
45	60	985	93,7	93,8	93,8	0,70	0,80	0,83	87,8	990	93,7	94,0	94,0	0,64	0,75	0,81	82,2		
55	75	987	94,0	94,2	94,2	0,70	0,79	0,83	107	989	94,0	94,3	94,3	0,63	0,75	0,81	100		
75	100	990	94,6	94,8	94,8	0,71	0,80	0,83	145	990	94,3	95,0	95,0	0,64	0,75	0,80	137		
90	125	990	95,0	95,1	95,1	0,72	0,80	0,84	171	990	95,0	95,1	95,2	0,65	0,76	0,81	162		
110	150	990	94,8	95,0	95,1	0,74	0,82	0,84	209	990	94,8	95,1	95,1	0,68	0,78	0,82	196		
132	175	990	95,4	95,8	95,6	0,69	0,79	0,84	250	990	95,4	95,8	95,6	0,65	0,75	0,80	240		
150	200	990	95,4	95,7	95,7	0,69	0,80	0,85	280	990	95,4	95,5	95,7	0,65	0,76	0,81	269		
160	220	990	95,5	95,8	95,8	0,71	0,80	0,84	302	990	95,3	95,8	95,8	0,64	0,75	0,81	287		
185	250	990	94,8	95,3	95,8	0,70	0,79	0,83	353	990	94,8	95,3	95,8	0,62	0,74	0,80	336		
200	270	992	95,7	96,0	95,8	0,70	0,79	0,82	387	993	95,3	95,9	95,9	0,63	0,74	0,79	367		
220	300	993	95,5	95,9	96,0	0,65	0,76	0,81	430	995	95,5	96,1	96,1	0,61	0,72	0,77	414		
250	340	992	95,8	95,8	95,8	0,68	0,77	0,80	496	994	95,5	96,0	96,0	0,61	0,73	0,78	464		
260	350	990	95,0	95,8	95,8	0,68	0,77	0,80	515	995	95,5	96,0	96,0	0,61	0,73	0,78	483		
280	380	993	95,7	96,1	96,0	0,68	0,77	0,81	547	994	95,2	95,9	96,1	0,61	0,72	0,78	520		
300	400	991	95,8	96,0	96,0	0,65	0,76	0,82	579	993	95,8	96,0	96,0	0,61	0,73	0,78	557		
315	430	990	95,8	96,2	96,0	0,68	0,78	0,81	615	993	95,3	96,0	96,1	0,61	0,73	0,78	585		
355	480	991	95,4	95,7	95,8	0,64	0,75	0,79	713	993	95,2	95,7	95,9	0,62	0,73	0,79	652		
370	500	990	95,6	95,8	95,8	0,65	0,76	0,81	724	995	95,2	95,7	95,9	0,61	0,72	0,77	697		
400	550	990	95,7	95,9	95,9	0,67	0,77	0,81	782	990	95,2	95,7	95,9	0,60	0,71	0,77	754		
VI pole - 1000 rpm - 50 Hz - Optional frames & high output designs																			
45	60	985	92,9	93,9	93,8	0,80	0,86	0,88	82,8	985	91,9	93,9	93,9	0,73	0,82	0,86	77,5		
75	100	990	94,4	94,6	94,6	0,67	0,78	0,83	145	990	93,8	94,6	94,7	0,60	0,72	0,79	139		
150	200	990	94,6	95,1	95,6	0,72	0,81	0,84	284	990	94,6	95,1	95,6	0,65	0,76	0,81	269		

## W22 - Premium Efficiency - IE3 <sup>(1)</sup>

Output		Frame	Full Load Torque (Nm)	Locked Rotor Current I <sub>L</sub> /I <sub>n</sub>	Locked Rotor Torque T <sub>L</sub> /T <sub>n</sub>	Break-down Torque T <sub>b</sub> /T <sub>n</sub>	Inertia J (kgm <sup>2</sup> )	Allowable locked rotor time (s)		Weight (kg)	Sound dB(A)	400 V								
								Hot	Cold			% of full load			Power Factor			Full load current I <sub>n</sub> (A)		
												Efficiency			Power Factor					
kW	HP										Rated speed (rpm)	50	75	100	50	75	100			
VIII pole - 750 rpm - 50 Hz																				
0,12	0,16	71	1,76	2,4	1,8	1,9	0,0009	30	66	11,8	41,0	650	44,0	50,0	52,5	0,35	0,43	0,50	0,660	
0,18	0,25	80	2,53	3,3	2,0	2,2	0,0029	30	66	14,9	42,0	680	51,0	57,0	58,7	0,45	0,55	0,65	0,681	
0,25	0,33	80	3,44	3,5	2,0	2,2	0,0034	30	66	15,6	42,0	695	53,0	60,0	64,1	0,42	0,52	0,63	0,894	
0,37	0,5	90S	5,05	3,7	2,0	2,3	0,0055	30	66	19,0	44,0	700	61,0	66,0	69,3	0,41	0,53	0,62	1,24	
0,55	0,75	90L	7,62	3,8	1,9	2,2	0,0066	29	64	23,0	44,0	690	65,0	70,0	73,0	0,44	0,57	0,67	1,62	
0,75	1	100L	10,1	4,6	1,9	2,3	0,0127	30	66	30,5	50,0	710	72,5	75,5	75,5	0,41	0,53	0,62	2,31	
1,1	1,5	100L	14,8	4,6	1,9	2,0	0,0143	30	66	33,0	50,0	710	73,0	76,0	77,7	0,41	0,53	0,62	3,30	
1,5	2	112M	20,3	5,0	2,5	2,8	0,0238	28	62	43,0	46,0	705	79,0	79,5	79,9	0,45	0,59	0,68	3,98	
2,2	3	132S	29,6	6,2	2,3	2,5	0,0690	27	59	67,7	48,0	710	81,5	82,0	82,1	0,51	0,65	0,72	5,37	
3	4	132M	40,4	6,4	2,4	2,6	0,0838	21	46	75,0	48,0	710	82,5	83,5	83,5	0,51	0,64	0,72	7,20	
4	5,5	160M	52,4	5,0	2,1	2,3	0,1229	34	75	110	51,0	730	85,0	86,0	86,0	0,47	0,61	0,68	9,87	
5,5	7,5	160M	72,5	5,0	2,1	2,3	0,1492	28	62	121	51,0	725	86,0	87,3	87,3	0,52	0,65	0,73	12,5	
7,5	10	160L	98,0	5,5	2,2	2,5	0,2199	22	48	152	51,0	731	86,5	88,0	88,4	0,46	0,59	0,68	18,0	
9,2	12,5	180M	121	6,0	2,0	2,6	0,2575	15	33	173	51,0	725	89,0	89,3	89,6	0,63	0,75	0,82	18,1	
11	15	180L	144	6,5	2,3	2,7	0,2846	12	26	178	51,0	730	88,7	89,2	89,7	0,55	0,68	0,76	23,3	
15	20	200L	196	4,8	1,9	2,1	0,4571	34	75	242	56,0	730	89,0	89,6	89,8	0,56	0,68	0,74	32,6	
18,5	25	225S/M	241	6,5	1,7	2,5	0,8219	28	62	361	56,0	735	89,8	90,3	90,3	0,63	0,75	0,81	36,5	
22	30	225S/M	286	7,0	2,1	2,7	0,9574	20	44	375	56,0	735	90,3	90,8	90,8	0,61	0,73	0,79	44,3	
30	40	250S/M	393	7,4	1,9	2,8	1,43	18	40	490	56,0	730	91,0	91,5	91,5	0,66	0,77	0,83	57,0	
37	50	280S/M	478	6,0	1,8	2,3	2,82	32	70	673	59,0	740	91,5	92,0	92,0	0,63	0,73	0,79	73,5	
45	60	280S/M	581	6,0	1,8	2,2	3,49	30	66	720	59,0	740	92,2	92,4	92,4	0,63	0,73	0,79	89,0	
55	75	315S/M	710	6,0	1,7	2,2	5,11	40	88	960	62,0	740	92,2	92,7	92,7	0,65	0,75	0,80	107	
75	100	315S/M	968	6,0	1,8	2,2	6,56	40	88	1012	62,0	740	92,8	93,3	93,3	0,65	0,75	0,80	145	
90	125	315S/M	1162	6,0	1,9	2,2	7,84	40	88	1100	62,0	740	93,1	93,6	93,6	0,65	0,75	0,80	173	
110	150	315L	1420	6,0	1,9	2,2	9,46	35	77	1367	68,0	740	93,4	93,9	93,9	0,64	0,74	0,79	214	
132	175	355M/L	1693	6,5	1,3	2,3	14,1	48	106	1587	70,0	745	93,7	94,2	94,2	0,64	0,74	0,79	256	
160	220	355M/L	2052	6,4	1,3	2,3	17,4	56	123	1747	70,0	745	94,0	94,5	94,5	0,64	0,75	0,80	305	
185	250	355M/L	2373	6,9	2,0	2,9	18,5	56	123	1819	70,0	745	93,4	94,7	94,7	0,63	0,73	0,78	361	
200	270	355M/L	2565	6,2	1,3	2,3	18,9	56	123	1891	70,0	745	94,3	94,8	94,8	0,65	0,76	0,80	381	
220	300	355M/L	2825	7,0	1,8	2,8	19,8	30	66	2020	70,0	744	94,8	95,1	95,2	0,60	0,72	0,78	428	
250	340	355A/B <sup>(4)</sup>	3211	6,2	1,6	2,5	21,7	47	103	2092	70,0	744	94,8	95,3	95,3	0,62	0,73	0,79	479	
260	350	355A/B <sup>(4)</sup>	3335	6,2	1,5	2,4	21,7	47	103	2092	70,0	745	94,8	95,3	95,3	0,62	0,73	0,79	498	
280	380	355A/B <sup>(4)</sup>	3591	7,8	2,2	3,1	25,0	30	66	2279	70,0	745	94,1	95,1	95,3	0,61	0,71	0,77	551	
VIII pole - 750 rpm - 50 Hz - Optional frames & high output designs																				
37	50	250S/M	484	8,0	2,3	3,0	1,61	12	26	550	56,0	730	91,5	92,0	92,0	0,60	0,72	0,79	73,5	
55	75	280S/M	710	5,8	2,0	2,1	3,38	26	57	812	59,0	740	92,2	92,7	92,7	0,60	0,71	0,77	111	
110	150	315S/M	1420	6,0	1,9	2,2	9,46	35	77	1360	62,0	740	93,4	93,9	93,9	0,64	0,74	0,79	214	

Note:  
 (1) Efficiency values are given according to IEC 60034-2-1. They are calculated according to indirect method, with stray load losses determined by measurement.  
 (4) Fitted with air deflector in the drive end side.

**W22 - Premium Efficiency - IE3 <sup>(1)</sup>**

Output		380 V									415 V								
		Rated speed (rpm)	% of full load						Full load current In (A)	Rated speed (rpm)	% of full load						Full load current In (A)		
			Efficiency			Power Factor					Efficiency			Power Factor					
kW	HP		50	75	100	50	75	100			50	75	100	50	75	100			
VIII pole - 750 rpm - 50 Hz																			
0,12	0,16	640	46,6	51,7	52,9	0,38	0,46	0,54	0,638	655	41,8	48,2	51,4	0,34	0,41	0,48	0,677		
0,18	0,25	670	52,8	58,0	58,7	0,48	0,59	0,69	0,675	685	49,3	56,0	58,7	0,43	0,53	0,62	0,688		
0,25	0,33	685	54,0	60,0	64,1	0,44	0,57	0,67	0,884	705	56,0	62,0	64,3	0,39	0,50	0,60	0,902		
0,37	0,5	690	61,0	66,0	69,3	0,44	0,56	0,66	1,23	710	62,0	67,0	69,5	0,38	0,50	0,59	1,26		
0,55	0,75	695	65,0	70,0	73,0	0,49	0,62	0,70	1,64	705	65,0	70,0	73,0	0,42	0,55	0,64	1,64		
0,75	1	705	73,9	76,1	75,1	0,44	0,57	0,66	2,30	715	71,1	74,8	75,5	0,38	0,50	0,59	2,34		
1,1	1,5	700	74,9	76,8	77,7	0,45	0,58	0,66	3,26	710	71,1	76,0	77,7	0,38	0,50	0,59	3,34		
1,5	2	700	79,0	79,5	79,7	0,49	0,63	0,71	4,03	710	77,9	79,7	79,9	0,42	0,56	0,65	4,02		
2,2	3	705	81,5	81,9	81,9	0,57	0,68	0,76	5,37	715	81,0	82,0	82,2	0,48	0,62	0,70	5,32		
3	4	705	83,4	83,5	83,5	0,56	0,68	0,75	7,28	715	81,5	83,2	83,7	0,48	0,61	0,70	7,12		
4	5,5	725	85,6	86,8	86,1	0,51	0,64	0,70	10,1	735	84,4	86,6	86,8	0,44	0,58	0,66	9,71		
5,5	7,5	720	86,7	87,3	87,2	0,56	0,68	0,76	12,6	730	85,2	87,0	87,8	0,49	0,62	0,71	12,3		
7,5	10	728	87,0	88,0	88,3	0,50	0,63	0,71	18,2	732	86,0	88,0	88,5	0,44	0,56	0,65	18,1		
9,2	12,5	720	88,5	89,0	89,0	0,67	0,78	0,84	18,7	730	88,6	89,3	90,0	0,60	0,73	0,80	17,8		
11	15	725	88,5	89,0	89,5	0,59	0,71	0,77	24,3	730	89,0	89,5	90,0	0,52	0,65	0,74	23,0		
15	20	730	90,5	91,0	91,0	0,60	0,71	0,76	33,0	730	89,0	89,6	89,8	0,53	0,65	0,72	31,7		
18,5	25	730	89,8	90,1	90,1	0,67	0,78	0,83	37,6	735	89,8	90,3	90,3	0,60	0,73	0,80	35,6		
22	30	730	90,3	90,6	90,6	0,65	0,76	0,81	45,5	735	90,3	90,8	90,8	0,57	0,70	0,77	43,8		
30	40	725	91,0	91,3	91,3	0,70	0,80	0,85	58,7	730	91,0	91,5	91,5	0,63	0,75	0,85	53,7		
37	50	740	91,5	91,8	91,8	0,67	0,76	0,81	75,6	740	91,5	92,0	92,0	0,60	0,71	0,77	72,7		
45	60	740	91,9	92,2	92,2	0,67	0,76	0,80	92,7	740	91,9	92,4	92,4	0,60	0,71	0,78	86,9		
55	75	740	92,2	92,5	92,5	0,69	0,77	0,81	112	740	92,2	92,7	92,7	0,62	0,73	0,79	104		
75	100	740	92,8	93,1	93,1	0,69	0,77	0,81	151	740	92,8	93,3	93,3	0,62	0,73	0,79	142		
90	125	740	93,1	93,4	93,4	0,69	0,77	0,81	181	740	93,1	93,6	93,6	0,62	0,73	0,79	169		
110	150	740	93,4	93,7	93,7	0,68	0,77	0,81	220	740	93,4	93,9	93,9	0,61	0,72	0,78	209		
132	175	743	93,7	94,0	94,0	0,66	0,75	0,81	263	745	93,7	94,2	94,2	0,60	0,71	0,77	253		
160	220	745	94,0	94,3	94,3	0,68	0,78	0,82	314	745	94,0	94,5	94,5	0,61	0,73	0,79	298		
185	250	744	93,6	94,6	94,6	0,67	0,76	0,80	371	745	93,2	94,8	94,8	0,60	0,70	0,76	357		
200	270	745	94,3	94,6	94,6	0,69	0,79	0,82	392	745	94,3	94,8	94,8	0,61	0,73	0,78	376		
220	300	743	94,8	95,1	95,2	0,67	0,75	0,79	444	745	94,8	95,1	95,2	0,63	0,73	0,78	412		
250	340	743	95,0	95,2	95,2	0,67	0,77	0,81	493	745	94,6	95,2	95,3	0,58	0,70	0,77	474		
260	350	745	95,0	95,2	95,2	0,67	0,77	0,81	512	745	94,6	95,2	95,3	0,58	0,70	0,77	493		
280	380	745	94,5	95,2	95,3	0,65	0,75	0,80	558	745	94,0	95,0	95,3	0,57	0,68	0,75	545		
VIII pole - 750 rpm - 50 Hz - Optional frames & high output designs																			
37	50	730	91,5	91,8	91,8	0,64	0,75	0,81	75,6	735	91,5	92,0	92,0	0,57	0,70	0,77	72,7		
55	75	740	92,2	92,5	92,5	0,65	0,74	0,78	116	745	92,2	92,7	92,7	0,57	0,69	0,75	110		
110	150	740	93,4	93,7	93,7	0,68	0,77	0,81	220	740	93,4	93,9	93,9	0,61	0,72	0,78	209		

# EFFICIENCY THAT TURNS INTO GREAT SAVINGS

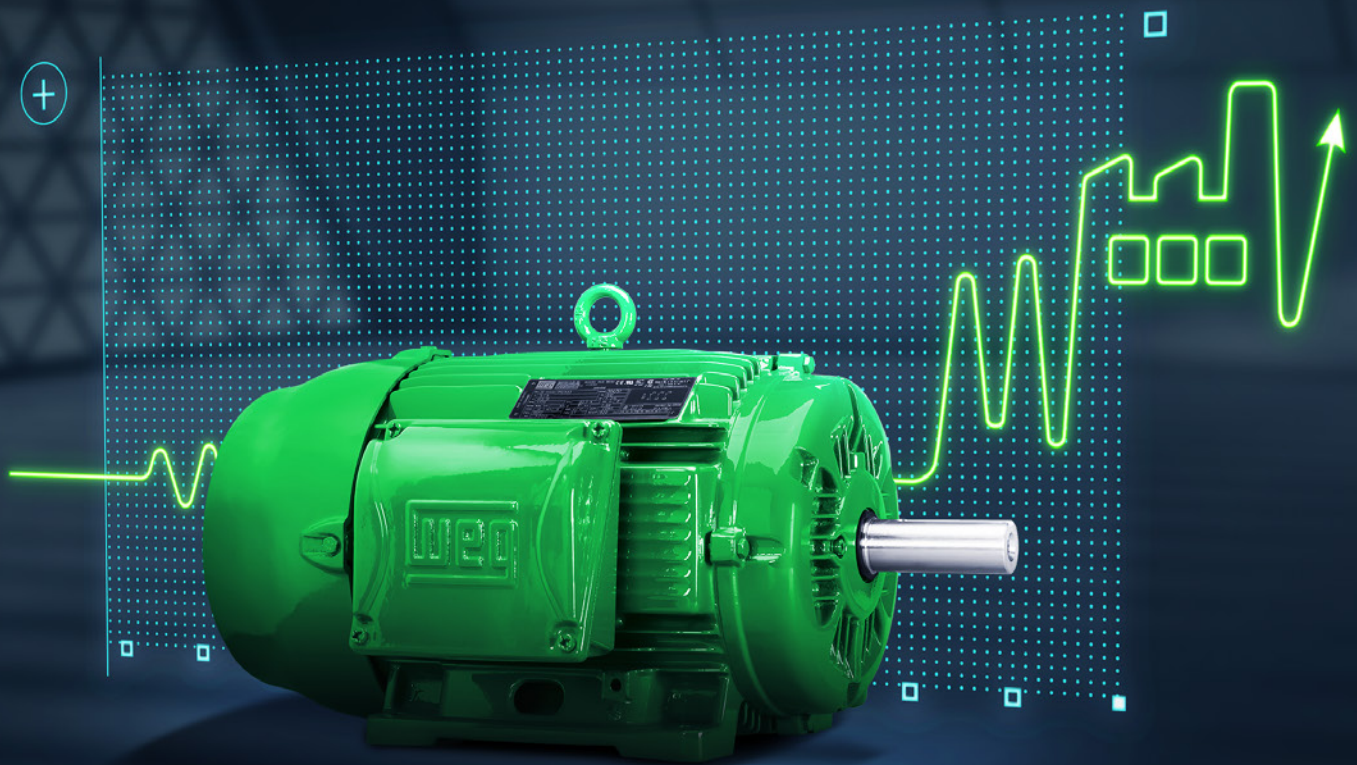

Transforming energy into solutions. [www.weg.net](http://www.weg.net)



# W22 SUPER PREMIUM

## PRESENTING THE WORLD'S HIGHEST AND WIDEST EFFICIENCY LEVEL INDUCTION MOTOR RANGE

In the last two decades, global energy consumption has increased by 50% with forecast for that the next two decades will continue to see significant increases in this usage.

This increasing demand for electrical energy to sustain global development requires consistent heavy investments in power supply generation. However, in addition to complex medium and long term planning, these investments rely on natural resources, which are becoming depleted due to constant pressures upon the environment.

As a reflection of this scenario, electric energy costs are rising dramatically, and in comparison to other economic indicators, standing out negatively.

One of the main contributing factors to this increase in power consumption is in the industrial sector, which utilises around 30% of the electrical energy globally available. And, in industrial applications, electric motor driven systems represents around 68% of all energy consumption.

Furthermore, if we consider both industrial and domestic applications, including appliances in our analysis, electric motors account for more than 40% of the total energy consumed Globally. This serves to emphasize the scale of worldwide electrical energy consumption by electric motors and the importance placed upon development of

more and more efficient products, not only to fulfil but to reduce this increasing demand, and consequently achieve energy / financial savings and emissions reduction.

In response to this situation, several Government Authorities are implementing Minimum Energy Efficiency Performance Standards, in order to encourage greater utilization of high-efficient equipment.

In Europe it was no different, and motor systems were earmarked as a priority target in the Eco-Design Directive (2005), which has established requirements for Energy-using Products: "EuP Directive". As a result, EU Mandatory Minimum Energy-Efficiency Performance Standard (MEPS) for industrial electric motors entered into force from July 2009.

With this situation in mind WEG presents its W22 Super Premium efficiency motor line, exceeding the IE4 Efficiency Levels defined in the IEC Standard 60034-30-1 from March 2014.

The efficiency performance of these motors far exceed the IE2 or IE3 minimum efficiency levels required in Europe today. This enables customers to reduce their Total Cost of Ownership through the reduction in energy consumption and consequently their carbon footprint.

HIGH OVERALL PERFORMANCE WHICH IS TRANSLATED INTO A LOWER TOTAL COST OF OWNERSHIP, DUE TO ITS RELIABILITY, EASY MAINTENANCE AND **ENERGY SAVINGS!**



**W22 - Super Premium Efficiency - IE4 <sup>(1)</sup>**

Output		Frame	Full Load Torque (Nm)	Locked Rotor Current I <sub>L</sub> /I <sub>n</sub>	Locked Rotor Torque T <sub>L</sub> /T <sub>n</sub>	Break-down Torque T <sub>b</sub> /T <sub>n</sub>	Inertia J (kgm <sup>2</sup> )	Allowable locked rotor time (s)		Weight (kg)	Sound dB(A)	400 V								
								Rated speed (rpm)	% of full load			Full load current I <sub>n</sub> (A)								
									Efficiency				Power Factor							
kW	HP							Hot	Cold				50	75	100	50	75	100		
VI pole - 1000 rpm - 50 Hz																				
3	4	132S	29,4	6,3	2,3	2,6	0,0568	48	106	61,0	52	975	88,0	89,3	88,6	0,53	0,66	0,73	6,69	
4	5,5	132M	39,4	6,6	2,5	3,1	0,0643	35	77	68,0	52	970	88,5	89,6	89,5	0,53	0,66	0,73	8,84	
5,5	7,5	L132M/L	53,9	7,3	2,5	3	0,0833	27	59	84,0	52	975	88,7	90,1	90,5	0,50	0,63	0,71	12,4	
7,5	10	160M	73,1	6,8	2,6	2,9	0,1931	21	46	130	56	980	90,6	91,5	91,3	0,60	0,73	0,80	14,8	
9,2	12,5	160L	89,7	7,7	3	3,6	0,2370	23	51	148	56	980	91,6	92,0	92,3	0,58	0,71	0,78	18,4	
11	15	160L	107	7,3	2,9	3,2	0,2370	14	31	150	56	980	90,3	91,5	92,3	0,55	0,68	0,77	22,3	
15	20	180L	146	8,2	2,8	3,4	0,3765	13	29	210	56	980	92,0	92,6	92,9	0,63	0,75	0,82	28,4	
18,5	25	200L	180	6,6	2,4	2,7	0,4896	23	51	235	60	980	92,7	93,2	93,4	0,63	0,75	0,81	35,3	
22	30	200L	213	7,0	2,6	2,9	0,5246	18	40	250	60	985	92,4	93,2	93,7	0,59	0,72	0,79	42,9	
30	40	225S/M	291	7,4	2,4	2,8	1,02	23	51	430	63	985	93,7	94,1	94,2	0,69	0,80	0,84	54,7	
37	50	250S/M	359	7,3	2,6	2,8	1,65	30	66	520	64	985	94,3	94,7	94,5	0,70	0,81	0,85	66,5	
45	60	280S/M	434	7,0	2,3	2,8	3,25	35	77	723	65	990	94,4	95,0	95,2	0,65	0,76	0,82	83,2	
55	75	280S/M	531	7,2	2,6	3	3,92	36	79	740	65	990	94,6	95,3	95,4	0,64	0,75	0,81	103	
75	100	315S/M	722	7,3	2,5	2,9	7,25	60	132	1106	67	993	95,3	96,0	96,2	0,67	0,77	0,82	137	
90	125	315S/M	869	6,7	2,2	2,4	7,96	48	106	1180	67	990	95,7	96,1	96,2	0,69	0,79	0,83	163	
110	150	315L	1058	6,9	2,5	2,6	9,04	44	97	1320	68	993	95,7	96,2	96,3	0,67	0,77	0,82	201	
132	175	315L	1274	7,2	2,6	2,7	9,95	36	79	1384	68	990	95,9	96,3	96,4	0,67	0,77	0,82	241	
150	200	315L	1448	7,2	2,7	2,6	11,0	30	66	1448	68	990	95,9	96,3	96,4	0,67	0,78	0,83	271	
160	220	315L	1544	7,2	2,7	2,6	11,0	30	66	1448	68	990	95,9	96,3	96,5	0,67	0,78	0,83	288	
185	250	355M/L	1777	6,6	2,1	2,4	13,2	50	110	1854	73	995	95,8	96,4	96,5	0,64	0,75	0,81	342	
200	270	355M/L	1921	6,6	2,2	2,3	14,1	48	106	1912	73	995	95,8	96,4	96,5	0,64	0,75	0,81	369	
220	300	355M/L	2123	6,5	2,1	2,3	15,0	48	106	1970	73	990	95,9	96,5	96,5	0,65	0,76	0,81	406	
250	340	355A/B <sup>(4)</sup>	2403	6,5	2,2	2,5	17,1	42	92	2246	73	994	95,9	96,5	96,6	0,66	0,76	0,80	467	
260	350	355A/B <sup>(4)</sup>	2509	6,5	2,2	2,3	17,1	42	92	2246	73	990	96,1	96,5	96,6	0,66	0,76	0,82	474	
280	380	355A/B <sup>(4)</sup>	2702	6,6	2,3	2,3	18,0	35	77	2300	73	990	95,8	96,4	96,6	0,64	0,75	0,81	517	
300	400	355A/B <sup>(4)</sup>	2895	6,5	2,2	2,3	18,9	35	77	2346	73	990	95,9	96,4	96,6	0,65	0,76	0,81	553	
315	430	355A/B <sup>(4)</sup>	3031	6,7	2,2	2,4	18,9	31	68	2346	73	993	95,7	96,3	96,6	0,63	0,74	0,80	588	

Note:

(1) Efficiency values are given according to IEC 60034-2-1. They are calculated according to indirect method, with stray load losses determined by measurement.

(4) Fitted with air deflector in the drive end side.

# 18. Mechanical Data

## Foot Mounted Motors, Terminal Box Top

### Frames 63 to L132M/L

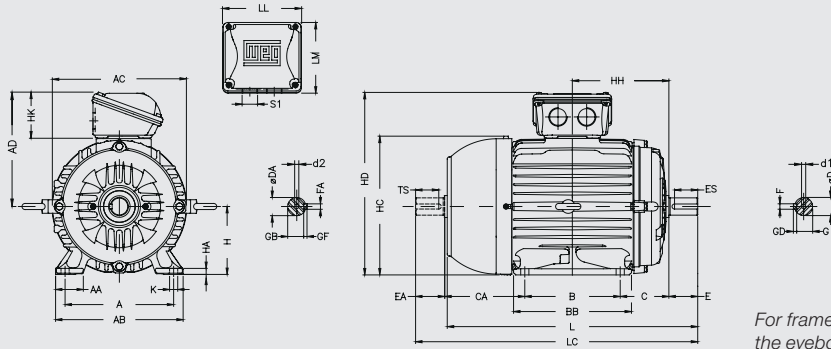

For frames 132S, 132M/L and 132M, the eyebolt will be fitted at 50°.

### Frames 160M to 200L

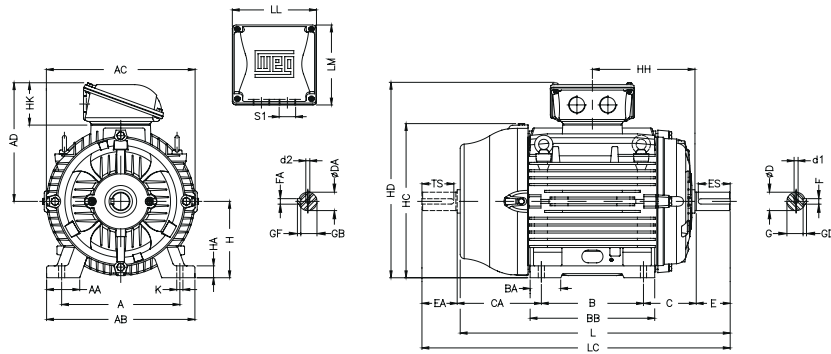

### Frames 225 to 355M/L\*

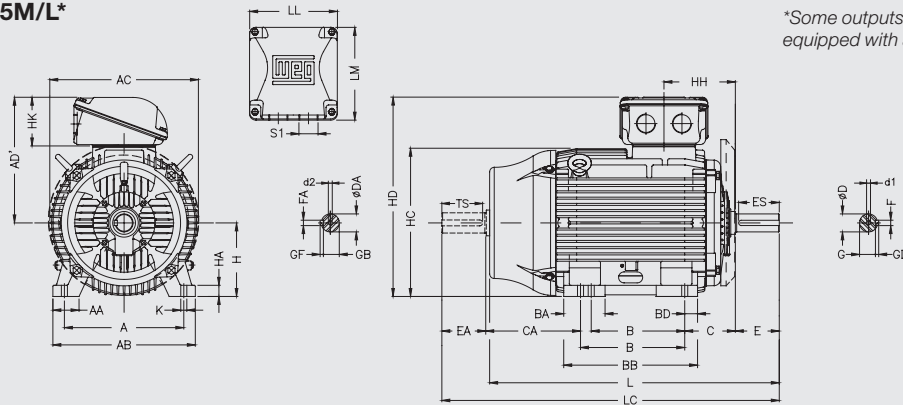

\*Some outputs in frame sizes 355M/L are equipped with an air deflector at the DE.

### Frame 355A/B

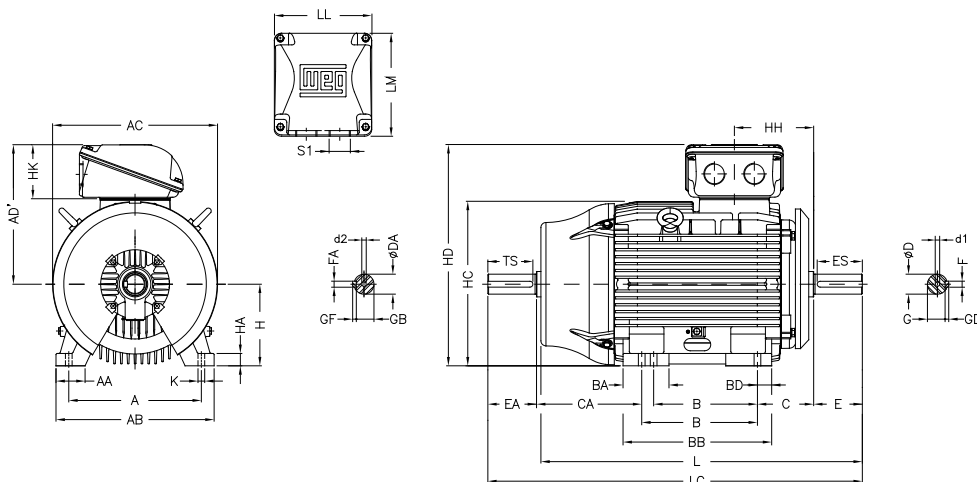



**Foot mounted motors, Terminal Box Left or Right Side**

**Frames 63 to 132M/L**

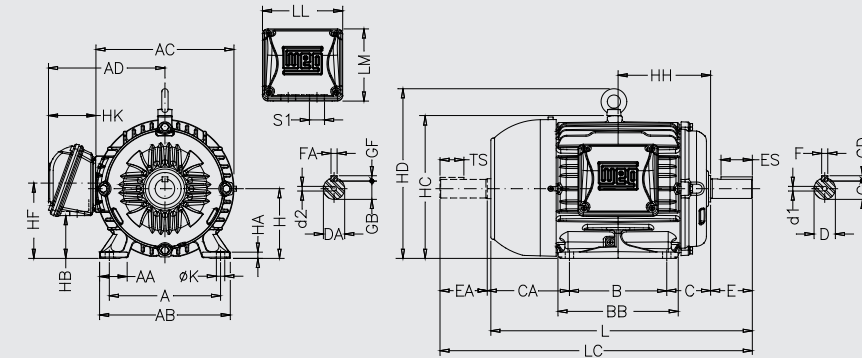

**Frames 160M to 200L**

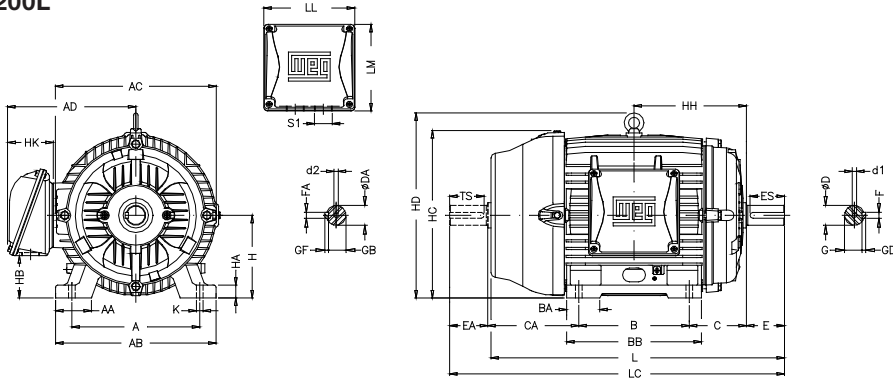

**Frames 225 to 355M/L\***

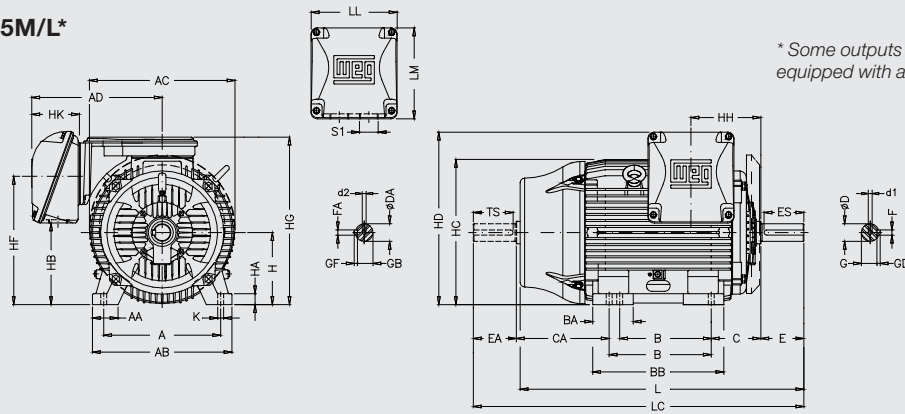

\* Some outputs in frame sizes 355M/L are equipped with an air deflector at the DE.

**Frame 355A/B**

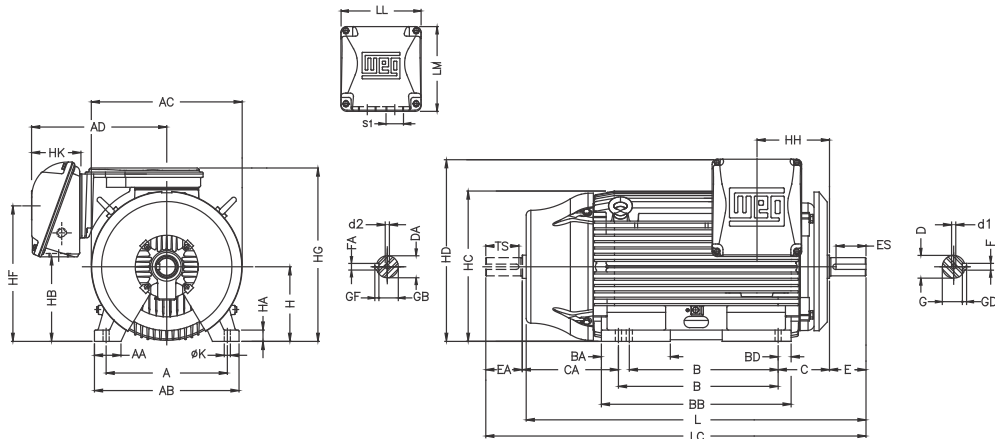



## Flange Mounted Motors

### “FF” Flange

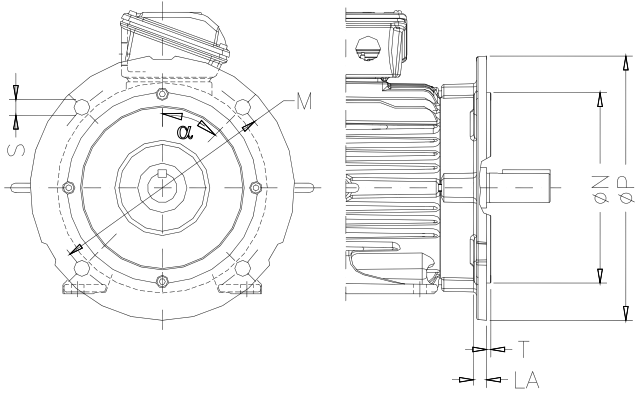

Frame	Flange	LA	M	N	P	S	T	$\alpha$	N° of holes
63	FF-115	5,5	115	95	140	10	3	45°	4
71	FF-130	7	130	110	160				
80	FF-165	9	165	130	200	12	3,5		
90		10							
100	FF-215	12,5	215	180	250	15	4		
112									
132	FF-265	12	265	230	300	19	5		
160	FF-300	18	300	250	350				
180			350	300	400				
200	FF-350	400	350	450					
225	FF-400	20	500	450	550	18	6	22°30'	8
250	FF-500								
280		18							
280	22	600	550	660/780*	24				
315S/M	FF-600	16							
315L		16							
355	FF-740	22	740	680	800/880*				

\*Only for motors fitted with air deflector in drive end side.  
 \*\* Dimensions are in mm.

### “C-DIN” Flange

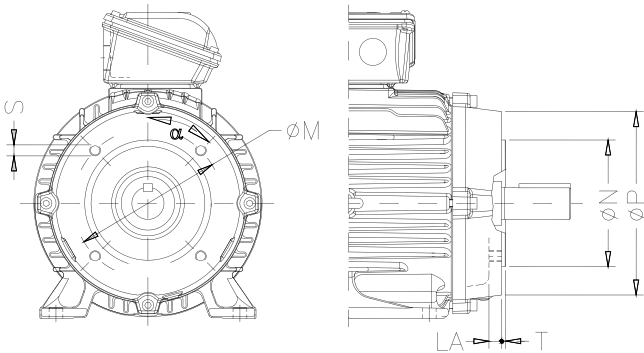

Frame	Flange	LA	M	N	P	S	T	$\alpha$	N° of holes
63	C-90	9,5	75	60	90	M5	2,5	45°	4
71	C-105	8	85	70	105	M6			
80	C-120	10,5	100	80	120		M8		
90	C-140	10,5	115	95	140	M10			
100	C-160	12	130	110	160				
112		13,5							
132	C-200	15,5	165	130	200				

\* Dimensions are in mm.



### “NEMA C” Flange

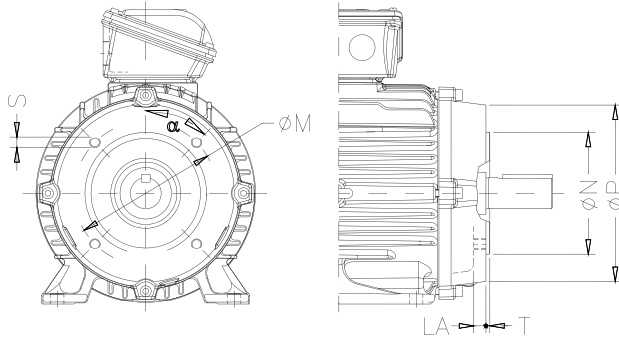

Frame	Flange	LA	M	N	P	S	T	$\alpha$	N° of holes
63	FC-95	4,5	95,2	76,2	143	UNC 1/4"x20	4	45°	4
71		10							
80		15							
90	FC-149	15	149,2	114,3	165	UNC 3/8"x16	6,3	22°30'	8
100		12							
112	FC-184	13,5	184,2	215,9	225	UNC 1/2"x13	6,3	45°	4
132		15,5							
160		26							
180	FC-228	20	228,6	266,7	280	UNC 5/8"x11	6,3	22°30'	8
200		25							
225		25							
250	FC-279	25	355,6	406,4	455	UNC 5/8"x11	6,3	22°30'	8
280		25							
315S/M	FC-368	18,5	368,3	419,1	455	UNC 5/8"x11	6,3	22°30'	8
315L		40							
355M/L		40							
355A/B		33,5							

\*Dimensions are in mm.

### Dimensions for motors with terminal box base

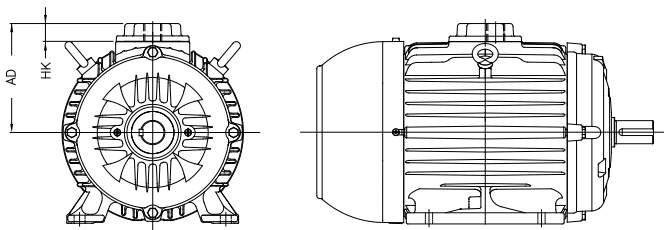

Frame	Threaded hole $\leq$ M20 or 1/2"		Threaded hole $>$ M20 or 1/2"	
	HK	AD	HK	AD
63	40	106	40	106
71		114		114
80	20	103	30	113
90		113		123
100		123		133
112	25	140	45	160
132		168		188

The optional terminal box base is not available in B30D, B30E, and B30T mountings.

\*Dimensions are in mm.

## 19. Terminal Box Drawings

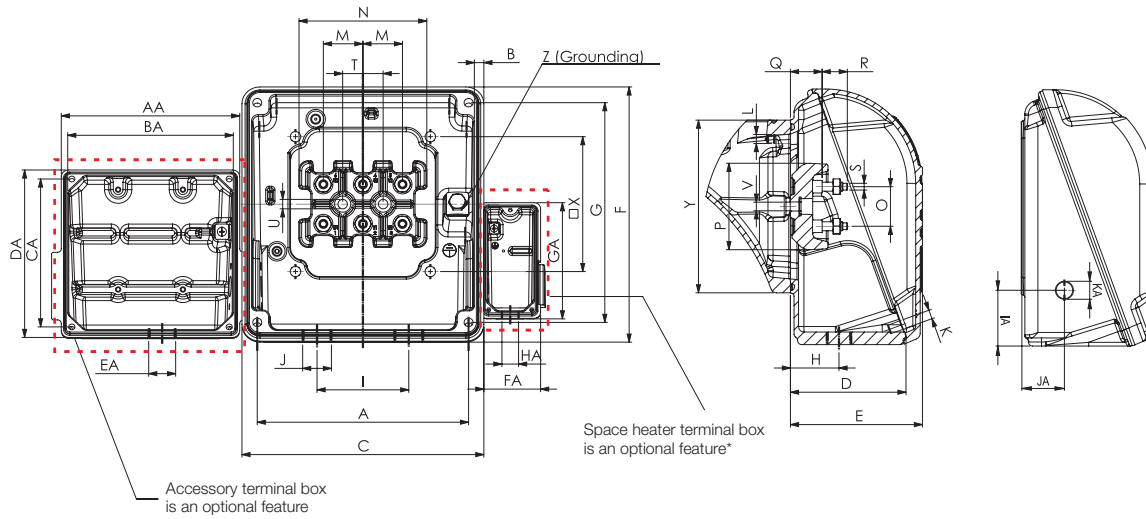

Frame	A	B	C	D	E	F	G	H	I	J	K	L	M	N	O	P	Q	R	S	T	U
63																					
71										2xM20x1,5											
80	90	3,5	108	51,5	59	98	85	27	42		M5x0,8	M5x0,8	16		16	35	13,5	12	M4x0,7	20	5,8
90														75							
100										2xM25x1,5											
112	117	2,5	140	71	80	133	117	36,5	54	2xM32x1,5	M6x1,0	M6x1,0	23		23	52	17	16	M5x0,8	23	6,5
132																					
160	175	4	198,5	90	101	190	175	46	84	2xM40x1,5	M8x1,25	M8x1,25	28	90	28	60	21,5	20,5	M6x1	28	6,6
180																					
200	204	4,5	230	107	119,5	220	204	59	94	2xM50x1,5			35	112	35	74	24	24	M8x1,25	35	9,5
225S/M	235	12,5	269		153	285	260	71	110		M10x1,5	M10x1,5	44	140	44	94	28	28	M10x1,5		
250S/M				133																	
280S/M	275	13,5	314		152	312	275		126												
315S/M	340		379	162	176	382	345	78	160	2xM63x1,5		M12x1,75	45	153	45	108	34	40	M12x1,75	45	10,5
315L		14,5																			
355M/L	365		404	202	220	436	390	97	200			M14x2,0	65	210	65	146	48	48		M16x2,0	65
355A/B	415	-	460	267	328	544	678	187	140	2xM80x2	M10x1,5	M12x1,75	80	-	105	-	-	-			-

Frame	V	X	Y	Z	AA	BA	CA	DA	EA	FA	GA	HA	IA	JA	KA	Max number of connectors									
																Main	Accessories	Space heater							
63			77																						
71			78																						
80	M5x0,8	56	81	0,5-6 mm <sup>2</sup>	109	90	85	98									4	16							
90			77																				23	17,5	
100			81																				25	22,5	
112			107																			2-10 mm <sup>2</sup>	35	20	
132	103																								
160	M6x1,0	110	140	5,2-25 mm <sup>2</sup>																					
180			155																			5,2-35 mm <sup>2</sup>	M20x1,5	68	M20x1,5
200	M8x1,25	120	155	5,2-35 mm <sup>2</sup>																					
225S/M	M10x1,5	150	192	25-50 mm <sup>2</sup>	139	117	117	133																	
250S/M			197																				47	45	
280S/M			204	35-70 mm <sup>2</sup>																		62	48	15	26
315S/M			260																			77	56		
315L			260	85-120 mm <sup>2</sup>																		82	69		
355M/L			300																			97	79		
355A/B	4xM6x1,5	290																							

Notes:

(\*) Space heater terminal box is a special feature for frame sizes 63 to 112.

(\*\*) Dimensions are in mm.

## 20. Drip Cover Data

Utilization of a drip cover / impact canopy increases the total length of the motor. The additional land length can be seen at table 22.

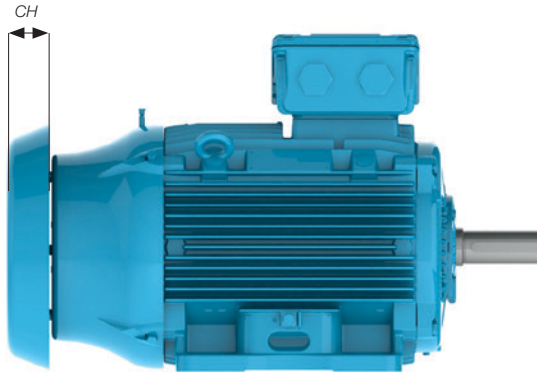

Figure 34 - Motor with drip cover

Frame	Dimension CH (increase motor length (mm))
63	18
71	
80	
90	
100	
100	28
112	31
132	
160	
180	57
200	67
225S/M	81
250S/M	
280S/M	91
315S/M	
315L	
355M/L	
355A/B	

Table 22 - Drip cover dimensions

## 21. External Motor Dimensions with Forced Ventilation

The use of forced ventilation increases the overall motor length, according to the table below.

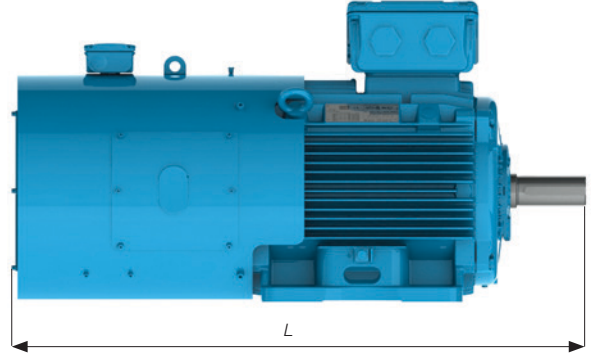

Figure 35 - Motor with forced ventilation

Frame size	Poles	Total motor length in mm (L)	
		Without forced ventilation	With forced ventilation
90S	All	304	548
L90S	All	335	579
90L	All	329	573
L90L	All	360	604
100L	All	376	646
L100L	All	418	690
112M	All	394	660
L112M	All	423	690
132S	All	452	715
132M	All	489	753
132M/L	All	515	778
160M	All	598	855
160L	All	642	899
180M	All	664	908
180L	All	702	946
200M	All	729	976
200L	All	767	1014
225S/M	2	856	1140
	4/8	886	1170
250S/M	2	965	1217
	4/8	965	1217
280S/M	2	1071	1348
	4/8	1071	1348
315S/M	2	1244	1459
	4/8	1274	1489
315L	2	1353	1568
	4/8	1389	1598
355M/L	2	1412	1786
	4/8	1482	1856
355A/B	2	1607	1981
	4/8	1677	2051

Table 23 - Forced ventilation dimensions

## 22. Silencer

The silencer for W22 motors reduces the noise level up to 5 dB(A), and it is available on 225 to 355 frames for foot-mounted and flange-mounted motors. It is made of 2 mm steel or stainless steel plate and is internally covered by a sound absorbing material. For foot-mounted the silencer fits loosely over the motor, and has a rubber strip to seal against the floor.

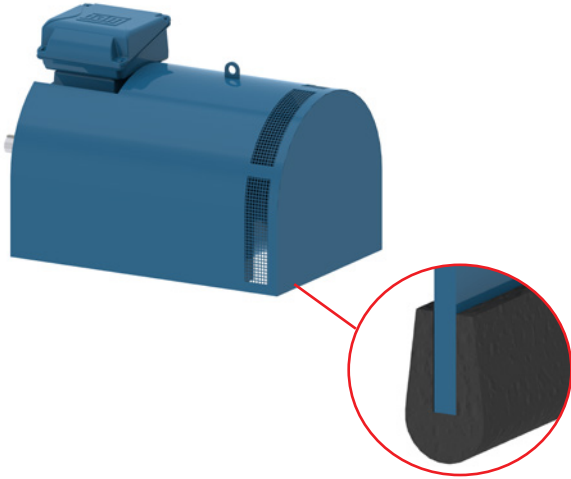
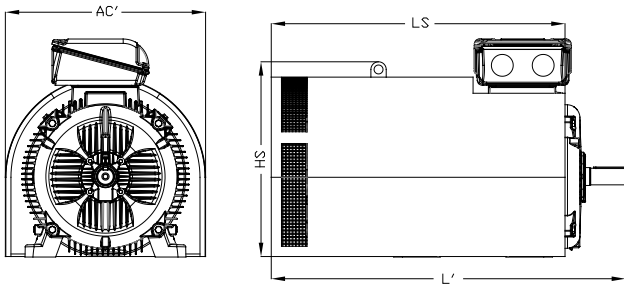

Figure 36 - Silencer for W22 motors.

### Silencer dimensional



Frame	AC'	L'	LS	HS
225S/M	564	955*	760	567
		985		
250S/M	604	1065	830	612
280S/M	704	1205	950	687
315S/M	784	1387*	1150	762
		1417		
355M/L	854	1587*	1305	834
		1657		
355A/B	854	1782*	1500	834
		1852		

\* Dimension for 2-pole motors.

\*\* Dimensions are in mm.

Table 24 - Silencer dimensional

## 23. Leveling screws and dowel pins

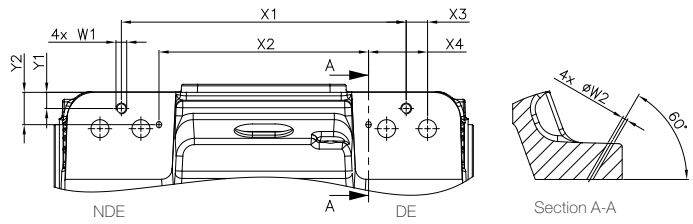

Figure 37 - Dimensions for motors with dowel pins and leveling screws

Frame	Threaded hole W1	Ø W2	X1	X2	X3	X4	Y1	Y2
160 M	M10x1,5	5	160	126	25	42	10	25
160 L	M10x1,5	5	204	170	25	42	10	25
180 M	M10x1,5	5	201	171	20	35	15	30
180 L	M10x1,5	5	239	209	20	35	15	30
200 M	M10x1,5	5	227	197	20	35	15	30
200 L	M10x1,5	5	265	235	20	35	15	30
225 S/M	M12x1,75	5	311	201	25	65	20	35
250 S/M	M12x1,75	5	349	219	25	65	20	35
280 S/M	M16x2,0	5	369	259	25	85	20	35
315 S/M	M16x2,0	5	457	281	50	100	30	50
315L	M16x2,0	5	508	361	50	115	30	50
355 M/L	M16x2,0	5	530	350	50	140	30	50
355 A/B	M16x2,0	5	710	545	50	140	30	50

\* Dimensions are in mm.

Table 25 - Dimensions for motors with dowel pins and leveling screws

## 24. Packaging

### 24.1 Frames 63 to 132

W22 motors in frames 63 to 132 are packaged in cardboard boxes (see figure 38), following the dimensions, weights and volumes of the tables 26 and 27.



Figure 38 - Cardboard box

Frame	External height (m)	External width (m)	External length (m)	Weight (kg)	Volume (m <sup>3</sup> )
63	0,26	0,21	0,30	0,2	0,02
71					
80					
L80	0,32	0,27	0,43	0,9	0,04
90S					
L90S					
L90L					
100L	0,33	0,27	0,46	1,4	0,04
L100L					
112M	0,36	0,30	0,46	1,5	0,05
L112M	0,42	0,33	0,60	1,5	0,08
132S	0,42	0,33	0,60	1,7	0,08
132M					
132M/L					

Table 26 - Cardboard box dimensions, weights and volumes for top mounting.

Frame	External height (m)	External width (m)	External length (m)	Weight (kg)	Volume (m <sup>3</sup> )
63	0,20	0,24	0,28	0,2	0,01
71	0,20	0,28	0,30	0,2	0,01
80	0,21	0,28	0,36	0,7	0,02
L80	0,24	0,32	0,40	0,8	0,03
90S					
L90S					
90L					
L90L	0,26	0,34	0,43	1,0	0,04
100L	0,27	0,35	0,46	1,6	0,04
L100L	0,32	0,37	0,50	1,4	0,06
112M	0,31	0,38	0,46	1,7	0,05
L112M	0,31	0,38	0,53	1,5	0,06
132S	0,35	0,48	0,60	2,1	0,10
132M					
132M/L					

Note: Values to be added to the net motor weight.

Table 27 - Cardboard box dimensions, weights and volumes for side mounting.

### 24.2 Frames 160 to 355A/B

For frames 160 to 355A/B, the motors are packaged in wooden crates (see figure 39). Dimensions, weights and volumes are in tables 28 and 29.



Figure 39 - Wooden crates

Frame	External height (m)	External width (m)	External length (m)	Weight (kg)	Volume (m <sup>3</sup> )
160	0,50	0,40	0,74	9,2	0,15
180	0,53	0,43	0,82	12,3	0,19
200	0,59	0,51	0,88	13,5	0,27
225S/M	0,90	0,85	1,15	51,9	0,88
250S/M	0,90	0,85	1,25	54,6	0,96
280S/M	1,13	0,85	1,40	67,9	1,34
315S/M	1,13	0,85	1,55	69,9	1,49
315L	1,20	0,90	1,70	111	1,84
355M/L	1,32	1,05	1,73	127	2,40
355A/B	1,32	1,05	1,90	141	2,63

Table 28 - Wooden crates dimensions, weights and volumes for top mounting.

Frame	External height (m)	External width (m)	External length (m)	Weight (kg)	Volume (m <sup>3</sup> )
160	0,40	0,51	0,74	9,85	0,15
180	0,45	0,57	0,82	13,42	0,21
200	0,49	0,63	0,88	14,58	0,27
225S/M	0,78	0,85	1,15	47,70	0,76
250S/M	0,90	0,85	1,25	52,20	0,96
280S/M	0,95	0,95	1,40	71,60	1,26
315S/M	1,13	1,10	1,75	88,40	2,18
315L	1,10	1,12	1,70	138,37	2,10
355M/L	1,20	1,19	1,72	146,00	2,46
355A/B	1,20	1,19	1,90	163,00	2,71

Note: Values to be added to the net motor weight.

Table 29 - Wooden crates dimensions, weights and volumes for side mounting.

## 25. Spare Parts

### 25.1 General Information

The following information is required when purchasing of spare parts:

- Serial number and manufacturing date, both stamped in the nameplate
- Spare part description
- Codes shown are for reference only. Final codes of spare parts will depend on colour

### Spare Parts Available 63-112

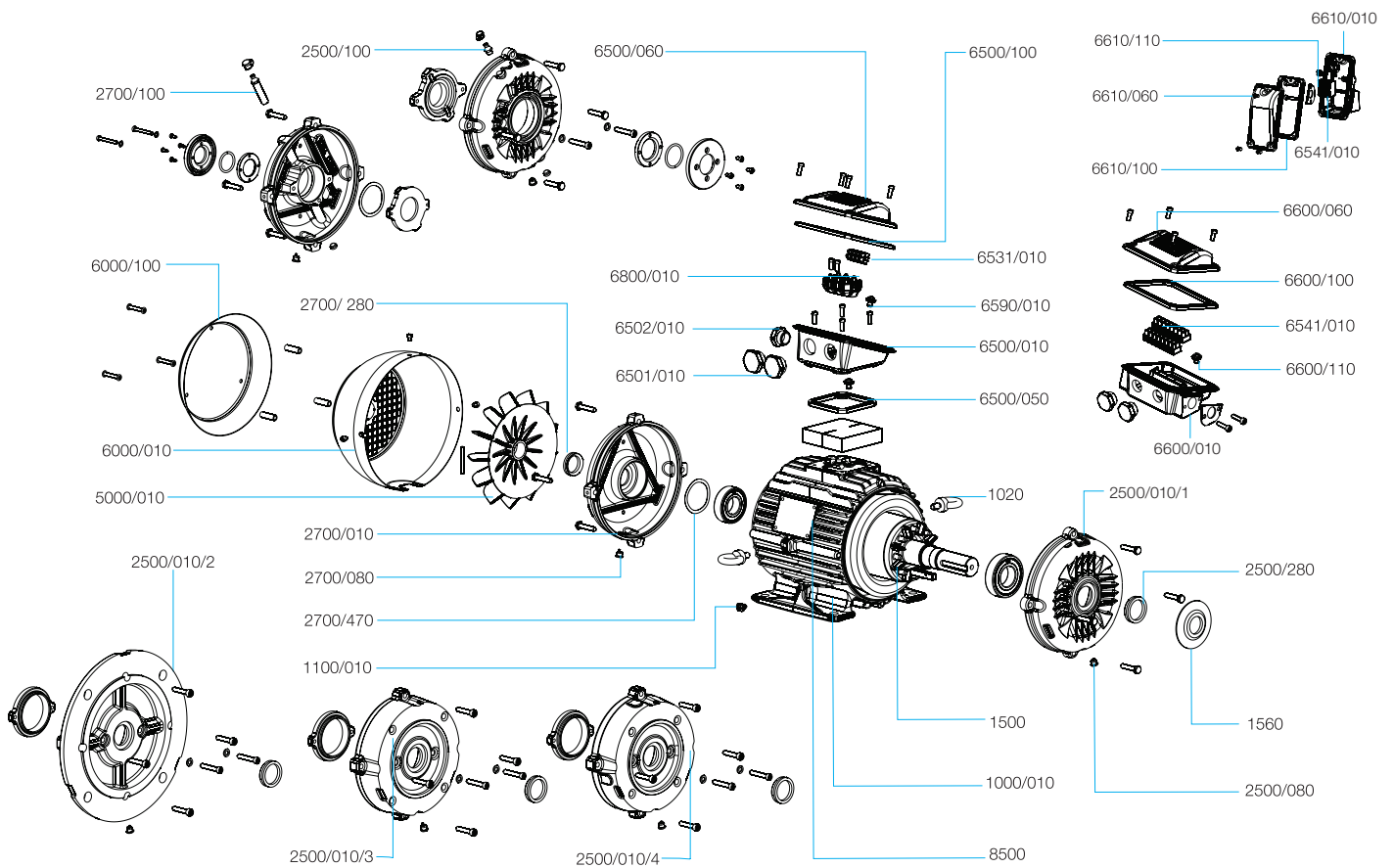

Component		Spare part	
Item	Description	Item	Composition
1000/010	Frame with wound stator	1000	Frame with wound stator
1020	Lifting eyebolt	1020	Lifting eyebolt
1100/010	Earthing terminal	1100	Earthing terminal
1500	Rotor, complete with shaft and key	1500	Rotor, complete with shaft and key
1560	Slinger	1560	Slinger (recommended for vertical shaft up applications, non-flange mounted)
2500/010/1	Endshield, drive end	2500/1	Endshield, drain plug, shaft seal, bolts and washers
2500/080	Drain plug, drive end		
2500/100	Grease nipple, drive end (2)		
2500/280	Shaft seal, drive end (1)		
2500/010/2	FF Flange	2500/2	FF Flange, drain plug, shaft seal, bolts and washers
2500/080	Drain plug, drive end		
2500/100	Grease nipple, drive end (2)		
2500/280	Shaft seal, drive end (1)		
2500/010/3	C Flange (5)	2500/3	C Flange, drain plug, shaft seal, bolts and washers
2500/080	Drain plug, drive end		
2500/100	Grease nipple, drive end (2)		
2500/280	Shaft seal, drive end (1)		
2500/010/4	C-DIN Flange (5)	2500/4	C-DIN Flange, drain plug, shaft seal, bolts and washers
2500/080	Drain plug, drive end		
2500/100	Grease nipple, drive end (2)		
2500/280	Shaft seal, drive end (1)		
2700/010	Endshield, non-drive end	2700	Endshield, drain plug, shaft seal, bolts and washers
2700/080	Drain plug, non-drive end		
2700/100	Grease nipple, non-drive end (2)		
2700/280	Shaft seal, non-drive end (1)		
2700/470	Wave washer for axial displacement		
5000/010	Cooling Fan	5000	Fan (3)
6000/010	Fan cover (4)	6000	Fan cover, bolts
		6050	Fan cover, drip cover and bolts
6000/100	Drip cover	6100	Drip cover, bolts
6500/010	Terminal box	6500	Terminal box complete with lid, gaskets (for lid and terminal box), plugs (for mains and accessories), earthing terminal, bolts and washers
6500/050	Terminal box gasket		
6500/060	Terminal box lid		
6500/100	Terminal box lid gasket		
6501/010	Terminal box plug for main leads		
6502/010	Terminal box plug for accessory leads		
6590/010	Terminal box earthing terminal		
6531/010	Accessory connector	6531	Accessory connector, mounting rail, bolts and washers
6541/010	Accessory connector	6541	Accessory connector, mounting rail, bolts and washers
6600/010	Accessory terminal box	6600	Accessory terminal box, complete with lid, gasket, plugs, earthing terminal, bolts and washers
6600/060	Accessory terminal box lid		
6600/100	Accessory terminal box lid gasket		
6600/110	Accessory terminal box earthing terminal		
6610/010	Space heater accessory terminal box	6610	Space heater accessory terminal box, complete with lid, gasket, plugs, earthing terminal, bolts and washers
6610/060	Space heater accessory terminal box lid		
6610/100	Space heater accessory terminal box lid gasket		
6610/110	Space heater accessory terminal box earthing terminal		
6800/010	Terminal block	6800	Terminal block, bolts and washers
8500	Main nameplate	8500	Main nameplate

Notes:

- (1) The shaft sealing may vary with product line. As a spare part, the shaft sealing in the 63-112 range will be supplied as an integral part of the endshield kit. If fitted with labyrinth seal, taconite or W3 Seal®, these are available available from 90 frame upwards.
- (2) When fitted with grease nipple, the endshield spare part kit will also have grease relief, internal bearing cap and labyrinth seal (taconite or W3 Seal®).
- (3) When non-plastic fan is fitted, the spare part kit is also supplied with key and circlip for fan assembly onto the shaft.
- (4) The fan cover material may vary with product line. Considering general purpose, it is fabricated steel in the 63-112 frame range.
- (5) C flange dimensions according to standards NEMA MG1 Part 4 or DIN.

### 25.2 Spare Parts Available 132-200

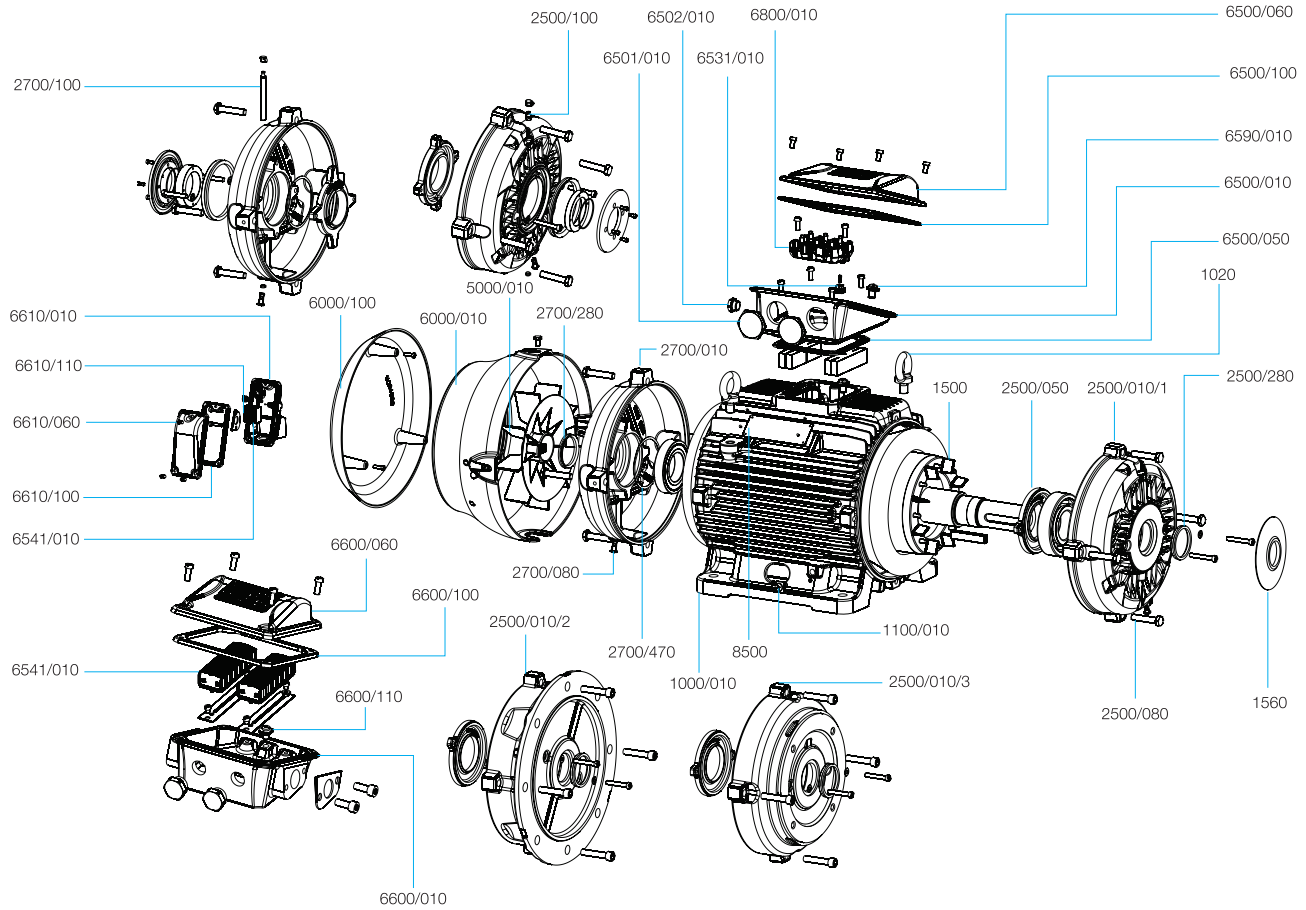



Motor component		Spare part	
Item	Description	Item	Composition
1000/010	Frame with wound stator	1000	Frame with wound stator
1020	Lifting eyebolt	1020	Lifting eyebolt
1100/010	Earthing terminal	1100	Earthing terminal
1500	Rotor, complete with shaft and key	1500	Rotor, complete with shaft and key
1560	Slinger	1560	Slinger (recommended for vertical shaft up applications, non-flange mounted)
2500/010/1	Endshield, drive end	2500/1	Endshield, bearing cap, drain plug, shaft seal, bolts and washers
2500/050	Bearing cap, internal, drive end		
2500/080	Drain plug, drive end		
2500/280	Shaft seal, drive end (1)		
2500/100	Grease nipple, drive end (2)		
2500/010/2	FF Flange	2500/2	FF Flange, drain plug, shaft seal, bolts and washers
2500/080	Drain plug, drive end		
2500/100	Grease nipple, drive end (2)		
2500/280	Shaft seal, drive end (1)		
2500/010/3	C Flange (7)	2500/3	C Flange, drain plug, shaft seal, bolts and washers
2500/080	Drain plug, drive end		
2500/280	Shaft seal, drive end (1)		
2500/100	Grease nipple, drive end (2)		
2700/010	Endshield, non-drive end	2700	Endshield, drain plug, shaft seal, bolts and washers
2700/080	Drain plug, non-drive end		
2700/100	Grease nipple (with extensor pipe), non-drive end (4)		
2700/280	Shaft seal, non-drive end (1)		
2700/470	Wave washer for axial displacement (3)		
5000/010	Fan	5000	Fan (5)
6000/010	Fan cover (6)	6000	Fan cover, bolts
		6050	Fan cover, drip cover and bolts
6000/100	Drip cover	6100	Drip cover and bolts
6500/010	Terminal box	6500	Terminal box, complete with lid, gaskets (for lid and terminal box), plugs (for mains and accessories), earthing terminal, bolts and washers
6500/050	Terminal box gasket		
6500/060	Terminal box lid		
6500/100	Terminal box lid gasket		
6501/010	Terminal box plug for main leads		
6502/010	Terminal box plug for accessory leads		
6590/010	Terminal box earthing terminal		
6531/010	Accessory connector	6531	Accessory connector, mounting rail, bolts and washers
6541/010	Accessory connector	6541	Accessory connector, mounting rail, bolts and washers
6600/010	Accessory terminal box	6600	Accessory terminal box, complete with lid, gasket, plugs, earthing terminal, bolts and washers
6600/060	Accessory terminal box lid		
6600/100	Accessory terminal box lid gasket		
6600/110	Accessory terminal box earthing terminal		
6610/010	Space heater accessory terminal box	6610	Space heater accessory terminal box, complete with lid, gasket, plugs, earthing terminal, bolts and washers
6610/060	Space heater accessory terminal box lid		
6610/100	Space heater accessory terminal box lid gasket		
6610/110	Space heater accessory terminal box earthing terminal		
6800/010	Terminal block	6800	Terminal block, bolts and washers
8500	Main nameplate	8500	Main nameplate

Notes:

- (1) The shaft seal may vary with product line. As a spare part, the shaft seal in the 132-200 range will be supplied as an integral part of the endshield kit. If fitted with labyrinth seal (taconite or W3 Seal) internal bearing cap is mandatory from frame 160.
- (2) When fitted with grease nipple, the endshield spare part kit will also have grease relief.
- (3) Valid when ball bearing is fitted in drive end. When the drive end is fitted with roller bearings, the wave washer is not supplied (non-drive end bearing locked with internal bearing cap).
- (4) When fitted with grease nipple in the non-drive end, the endshield spare part kit will also have grease relief and internal bearing cap.
- (5) When non-plastic fan is fitted, the spare part kit is also supplied with key and circlip for fan assembly onto the shaft.
- (6) The fan cover material may vary with product line. Considering general purpose, it is cast iron in the 160-200 range and fabricated steel in 132 frame.
- (7) C flange dimensions according to NEMA MG1 Part 4 standard (frames 132-200) or DIN standard (frame 132)..

### 25.3 Spare Parts Available 225 - 355

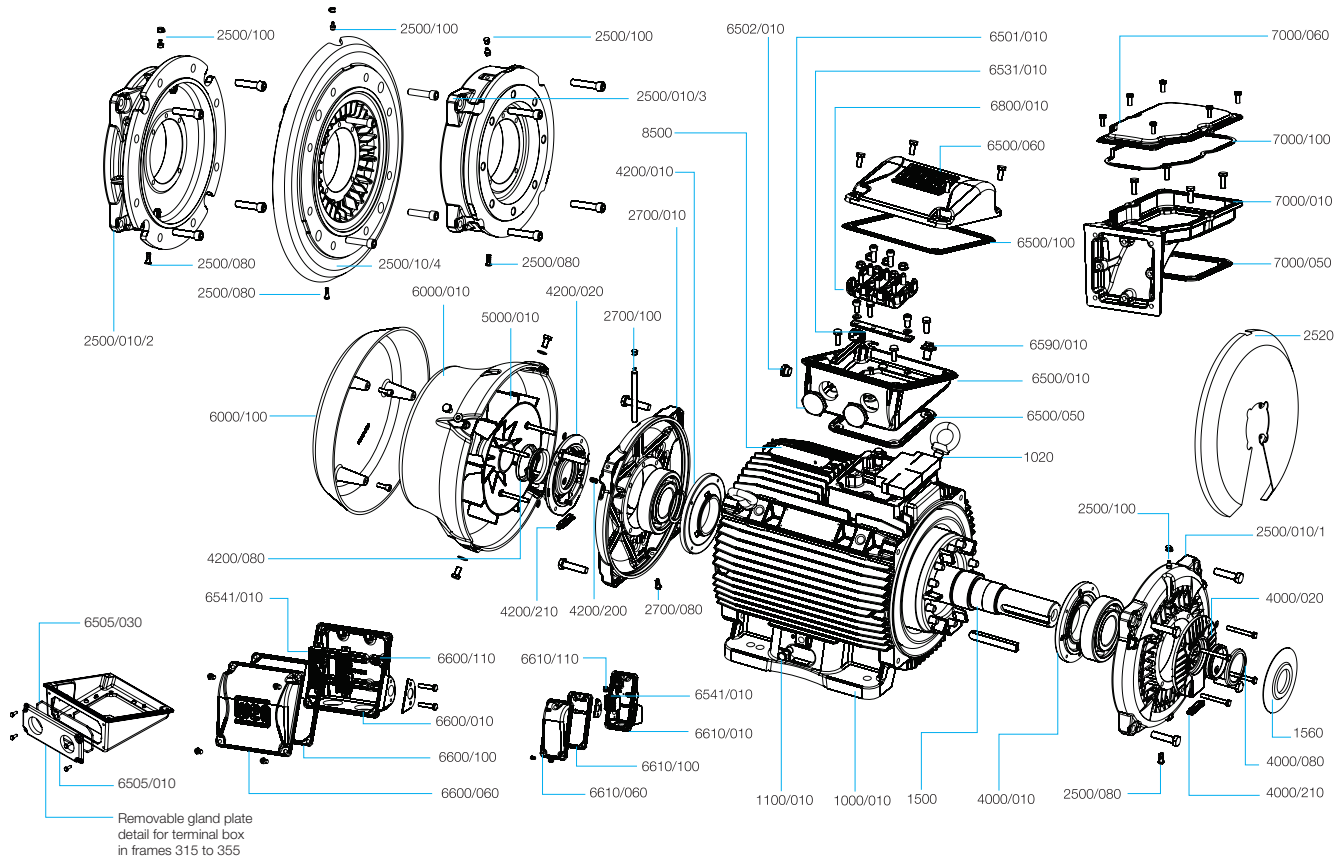

Motor component		Spare part	
Item	Description	Item	Composition
1000/010	Frame with wound stator	1000	Frame with wound stator
1020	Lifting eyebolt	1020	Lifting eyebolt
1100/010	Earthing terminal	1100	Earthing terminal
1500	Rotor, complete with shaft and key	1500	Rotor, complete with shaft and key
1560	Slinger	1560	Slinger
2500/010/1	Endshield, drive end	2500/1	Endshield, grease nipple, drain plug, bolts and washers
2500/080	Drain plug, drive end		
2500/100	Grease nipple, drive end		
2500/010/2	FF Flange	2500/2	FF Flange, grease nipple, drain plug, bolts and washers
2500/080	Drain plug, drive end		
2500/100	Grease nipple, drive end		
2500/0010/3	C Flange (5)	2500/3	C Flange, grease nipple, drain plug, bolts and washers
2500/080	Drain plug, drive end		
2500/100	Grease nipple, drive end		
2500/010/4	FF Flange with air deflector	2500/4	FF Flange with air deflector, grease nipple, drain plug, bolts and washers
2500/080	Drain plug, drive end		
2500/100	Grease nipple, drive end		
2520	Air Deflector	2520	Air Deflector
2700/010	Endshield, non-drive end	2700	Endshield, grease nipple with extensor pipe, drain plug, bolts and washers
2700/080	Drain plug, non-drive end		
2700/100	Grease nipple (with extensor pipe), non-drive end		
4000/010	Bearing cap, internal, drive end	4000	Bearing cap (external and internal), shaft seal, grease relief, bolts and washers
4000/020	Bearing cap, external, drive end		
4000/080	Shaft seal, drive end (1)		
4000/210	Grease relief		
4200/010	Bearing cap, internal, non-drive end	4200	Bearing cap (external and internal), shaft seal, grease relief with extensor pipe, pre-load springs, bolts and washers
4200/020	Bearing cap, external, non-drive end		
4200/080	Shaft seal, non-drive end (1)		
4200/200	Pre-load springs for axial displacement (2)		
4200/210	Grease relief		
5000/010	Fan	5000	Fan (3)
6000/010	Fan cover, cast iron	6000	Fan cover
		6050	Fan cover and canopy
		6100	Canopy
6500/010	Terminal box	6500	Terminal box, complete with lid, gaskets (for lid and terminal box), plugs (for mains and accessories), earthing terminal, bolts and washers
6500/050	Terminal box gasket		
6500/060	Terminal box lid		
6500/100	Terminal box lid gasket		
6501/010	Terminal box plug for main leads		
6502/010	Terminal box plug for accessory leads		
6505/010	Terminal box removable cable gland		
6505/030	Lid gasket of the terminal box removable cable gland		
6531/010	Accessory connector	6531	Accessory connector, mounting rail, bolts and washers
6541/010	Accessory connector	6541	Accessory connector, mounting rail, bolts and washers
6590/010	Terminal box earthing terminal	6800	Terminal block, mounting rail, bolts and washers
6800/010	Terminal block		
6600/010	Accessory terminal box	6600	Accessory terminal box, complete with lid, gasket, plugs, earthing terminal, bolts and washers
6600/060	Accessory terminal box lid		
6600/100	Accessory terminal box lid gasket		
6600/110	Accessory terminal box earthing terminal		
6610/010	Space heater accessory terminal box	6610	Space heater accessory terminal box, complete with lid, gasket, plugs, earthing terminal, bolts and washers
6610/060	Space heater accessory terminal box lid		
6610/100	Space heater accessory terminal box lid gasket		
6610/110	Space heater accessory terminal box earthing terminal		
7000/010	Terminal box adaptor base	7000	Terminal box adaptor for side mounted position, complete with lid, gaskets, bolts and washers
7000/050	Terminal box adaptor base gasket		
7000/060	Terminal box adaptor lid		
7000/100	Terminal box adaptor lid gasket		
8500	Main nameplate (4)	8500	Main nameplate

Notes:

- (1) The shaft sealing may vary with product line. As a spare part, the shaft sealing in the 225-355 range will be supplied as an integral part of the bearing cap kit.
- (2) Valid when ball bearing is fitted in drive end. When the drive end is fitted with roller bearings, pre-load springs are not supplied (non-drive end bearing locked).
- (3) When non-plastic fan is fitted, the spare part kit is also supplied with key and circlip for fan assembly onto the shaft.
- (4) Main nameplate position will vary with terminal box configuration (top and side mounting)
- (5) C flange dimensions according to NEMA MG1 Part 4 standard.

For WEG's worldwide  
operations visit our website



[www.weg.net](http://www.weg.net)



 +55 47 3276.4000

 [motores@weg.net](mailto:motores@weg.net)

 Jaraguá do Sul - SC - Brazil

Cod: 50025712 | Rev: 32 | Date (m/a): 11/2020

The values shown are subject to change without prior notice.  
The information contained is reference values.