

Locking Assemblies for Bending Loads

RINGFEDER® RfN 7012 M_b 40%

Extreme loads in belt drums

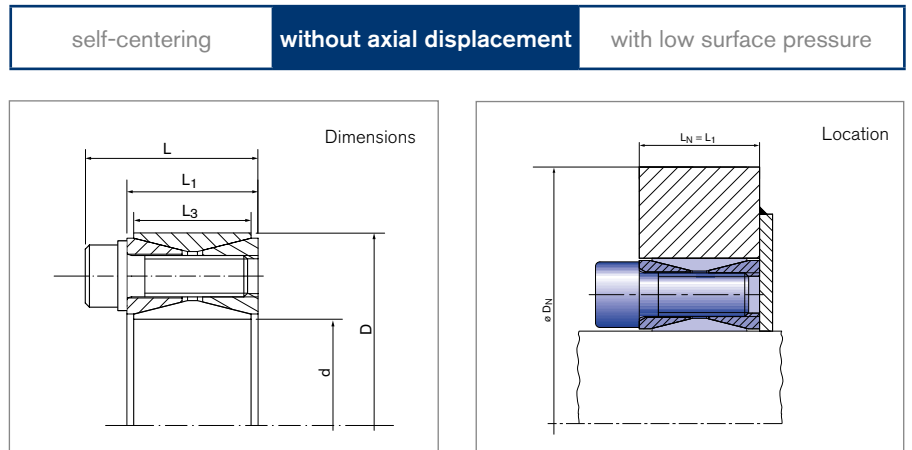

Locking Assembly dimensions		Clamping screws ISO 4762-12.9			T without	PW without	PN without	M _b 40%	T _{res} at M _b 40%	PW _{max} at M _b 40%	PN _{max} at M _b 40%	PW _{min} at M _b 40%	PN _{min} at M _b 40%	F _{ax} at M _b 40%	DN min at R _{p0,2}			Gw
		n _{Sc}	D _G	T _{Ared.}											M _b	M _b	M _b	
d	x D		mm	Nm	Nm	N/mm ²			Nm	N/mm ²				kN	mm			kg
50	x 80	12	8 x 22	35	1777	189	118	700	1633	239	149	139	87	65	160	127	114	0,6
55	x 85	14	8 x 22	35	2267	199	129	455	2221	228	148	169	110	81	168	134	120	0,63
60	x 90	14	8 x 22	35	2460	181	121	760	2340	226	151	136	91	78	182	143	128	0,69
65	x 95	16	8 x 22	35	3030	190	130	520	2985	219	150	162	111	92	191	151	135	0,73
70	x 110	14	10 x 25	70	4581	207	132	1260	4404	254	161	160	102	126	237	181	160	1,26
75	x 115	14	10 x 25	70	4887	192	125	1260	4722	236	154	148	97	126	236	185	165	1,33
80	x 120	14	10 x 25	70	5192	179	120	1690	4909	234	156	124	83	123	250	194	173	1,4
85	x 125	16	10 x 25	70	6281	192	131	1150	6175	227	155	157	107	145	259	202	180	1,49
90	x 130	16	10 x 25	70	6627	182	125	1570	6438	226	157	135	94	143	273	211	188	1,53
95	x 135	18	10 x 25	70	7843	192	135	1031	7775	220	155	164	115	164	279	218	194	1,62
100	x 145	14	12 x 30	125	9591	196	135	2884	9147	250	172	141	98	183	339	250	217	2,01
110	x 155	14	12 x 30	125	10488	177	126	3136	10008	230	164	123	87	182	340	258	228	2,15
120	x 165	16	12 x 30	125	13004	184	134	3584	12501	240	175	128	93	208	393	287	250	2,35
130	x 180	20	12 x 35	125	17522	162	117	4524	16928	211	153	112	81	260	367	288	257	3,51
140	x 190	22	12 x 35	125	20661	164	121	4064	20258	206	152	123	91	289	385	303	271	3,85
150	x 200	24	12 x 35	125	24046	167	125	3608	23773	201	151	133	99	317	403	318	284	4,07
160	x 210	26	12 x 35	125	27674	169	129	3148	27495	197	150	141	107	344	420	333	298	4,3
170	x 225	22	14 x 40	190	32486	157	119	8628	31320	211	159	103	78	368	479	369	327	5,78
180	x 235	24	14 x 40	190	37391	161	123	7584	36613	206	158	116	89	407	495	383	340	6,05
190	x 250	28	14 x 45	190	45890	147	111	9628	44869	185	140	108	82	472	473	383	346	8,25
200	x 260	30	14 x 45	190	51590	149	114	8460	50892	181	139	117	90	509	488	397	359	8,65
220	x 285	26	16 x 50	295	66374	146	112	13068	65075	184	142	107	82	592	545	440	396	11,22
240	x 305	30	16 x 50	295	83094	153	120	8132	82695	175	138	131	103	689	568	463	420	12,2
260	x 325	34	16 x 50	295	101512	159	127	6724	101289	176	141	142	114	779	616	499	450	13,2
280	x 355	32	18 x 60	405	124233	140	111	15376	123278	166	131	115	90	881	635	527	480	19,2

To continue see next page

Locking Assemblies for Bending Loads RINGFEDER® RfN 7012 M_b 40%

Locking Assembly dimensions			Clamping screws ISO 4762-12.9			T without M _b	P _W without M _b	P _N without M _b	M _b 40%	T _{res} at M _b 40%	P _W max at M _b 40%	P _N max at M _b 40%	P _W min at M _b 40%	P _N min at M _b 40%	F _{ax} at M _b 40%	D _N min at R _{P0,2}			G _w
			n _{Sc}	D _G	T _{Ared.}											M _b	M _b	M _b	
d	x	D	mm	Nm	Nm	N/mm ²			Nm	N/mm ²				kN	mm			kg	
mm																			
300	x	375	36	18 x 60	405	149101	146	117	9928	148770	162	130	131	105	992	667	554	505	20,5
320	x	405	36	20 x 70	580	207104	149	118	14888	206568	165	130	134	105	1291	722	599	546	29,6
340	x	425	36	20 x 70	580	219216	140	112	23168	217988	162	130	117	94	1282	757	629	573	31,1
360	x	455	36	22 x 80	780	282418	138	109	29852	280836	158	125	117	92	1560	790	663	607	42,2
380	x	475	36	22 x 80	780	297102	130	104	34800	295057	153	122	107	86	1553	812	685	629	44
400	x	495	36	22 x 80	780	311738	123	99	60184	305873	161	130	85	69	1529	881	732	667	46
420	x	515	40	22 x 80	780	362587	130	106	37432	360649	152	124	108	88	1717	888	747	684	50
440	x	545	40	24 x 90	1000	442836	126	102	45256	440517	146	118	106	86	2002	912	775	714	64,6
460	x	565	40	24 x 90	1000	461680	121	98	70932	456199	151	123	91	74	1983	967	815	748	67,4
480	x	585	42	24 x 90	1000	504497	121	99	67256	499994	148	122	94	77	2083	996	842	773	71
500	x	605	44	24 x 90	1000	549139	121	100	63584	545446	146	121	97	80	2182	1025	868	797	72,6
520	x	630	45	24 x 90	1000	582655	119	98	77792	577438	148	122	90	74	2221	1076	908	833	80
540	x	650	45	24 x 90	1000	603639	114	95	103468	594705	152	126	77	64	2203	1132	948	868	82
560	x	670	48	24 x 90	1000	666213	117	98	85120	660753	147	123	88	73	2360	1148	967	887	85
580	x	690	50	24 x 90	1000	717182	118	99	81444	712543	145	122	91	76	2457	1177	994	912	88
600	x	710	50	24 x 90	1000	740342	114	96	107119	732551	148	125	79	67	2442	1233	1034	946	91
620	x	730	52	24 x 90	1000	793992	114	97	103444	787225	147	124	82	69	2539	1262	1060	971	93
640	x	750	54	24 x 90	1000	849441	115	98	99771	843561	145	124	84	72	2636	1291	1086	995	96
660	x	770	56	24 x 90	1000	906684	115	99	96096	901577	143	123	87	74	2732	1319	1112	1020	99
680	x	790	56	24 x 90	1000	932418	111	96	121768	924433	146	126	77	66	2719	1375	1152	1054	102
700	x	810	60	24 x 90	1000	1026541	116	100	88748	1022697	140	121	91	79	2922	1377	1164	1069	104
720	x	830	60	24 x 90	1000	1054013	112	97	114420	1047784	143	124	82	71	2911	1433	1204	1103	107
740	x	850	62	24 x 90	1000	1117486	113	98	110748	1111984	142	123	84	73	3005	1461	1230	1127	110
760	x	870	64	24 x 90	1000	1182737	113	99	107072	1177881	141	123	86	75	3100	1490	1256	1152	113
780	x	890	65	24 x 90	1000	1230829	112	98	118072	1225152	141	124	86	72	3141	1532	1289	1181	116
800	x	910	66	24 x 90	1000	1279783	111	97	129072	1273258	142	125	79	70	3183	1574	1322	1210	118
820	x	930	68	24 x 90	1000	1349444	111	98	125400	1343605	141	124	81	72	3277	1603	1348	1235	121
840	x	950	70	24 x 90	1000	1420874	111	98	121724	1415650	139	123	83	74	3371	1631	1374	1259	124
860	x	970	72	24 x 90	1000	1494068	112	99	118052	1489397	138	123	85	75	3464	1660	1399	1284	127
880	x	990	74	24 x 90	1000	1569025	112	100	114376	1564851	137	122	87	77	3556	1688	1425	1308	129
900	x	1010	75	24 x 90	1000	1624087	111	99	125376	1619240	138	123	84	75	3598	1730	1458	1337	132
920	x	1030	76	24 x 90	1000	1680004	110	98	136376	1674459	138	124	81	72	3640	1772	1491	1367	135
940	x	1050	78	24 x 90	1000	1759331	110	99	132700	1754319	137	123	83	74	3733	1801	1517	1391	138
960	x	1070	80	24 x 90	1000	1840411	110	99	129028	1835883	136	122	84	76	3825	1829	1543	1415	140
980	x	1090	81	24 x 90	1000	1899788	109	98	140028	1894620	137	123	82	73	3867	1871	1576	1445	143
1000	x	1110	82	24 x 90	1000	1960015	108	98	151028	1954188	138	124	79	71	3908	1913	1608	1474	146

More sizes on request
To continue see next page

Locking Assemblies for Bending Loads RINGFEDER® RfN 7012 M_b 40%

Explanations

Basic dimensions when screws are not tightened			
d	= Inner diameter	p_{Wmin} bei M_b40%	= Min. surface pressure on shaft at 40% bending moment
D	= Outer diameter	p_{Nmin} bei M_b40%	= Min. surface pressure on hub at 40% bending moment
n_{Sc}	= Quantity of screws	F_{ax} bei M_b40%	= Transmissible axial force at 40% bending moment
D_G	= Thread	DN min bei Rp0,2	
T_{Ared.}	= Redused tightened torque of the screws under bending load	250 N/mm² + M_b40%	= Min. hub outer diameter depending of the given hub yield point Rp0,2 and part of bending moment
T ohne M_b	= Transmissible torque at given T _A	350 N/mm² + M_b40%	= Min. hub outer diameter depending of the given hub yield point Rp0,2 and part of bending moment
p_W ohne M_b	= Surface pressure on shaft at given T _A	450 N/mm² + M_b40%	= Min. hub outer diameter depending of the given hub yield point Rp0,2 and part of bending moment
p_N ohne M_b	= Surface pressure on hub at given T _A		
M_b40%	= 40% of max. bending moment	G_w	= Weight
T_{res.} bei M_b40%	= Remaining transmissible torque at indicated Mb40% and specified torque		
p_{Wmax.} bei M_b40%	= Max. surface pressure on shaft at 40% bending moment		
p_{Nmax.} bei M_b40%	= Max. surface pressure on hub at 40% bending moment		

Ordering example

Type	d	D
RfN 7012	160	210

Technical Information

- Surface finishes: Shaft and hub bores Ra ≤ 3,2 μm
- Tolerances: Shaft: h9 · Hub: H9

Remark: The Values of the shaft- and hub pressures have been calculated with the screw tightening shown in the tables. Increase resp. reduction of the screw tightening torque results in different calculation values!

Further information on
RINGFEDER® RfN 7012
 for Bending Loads
 on www.ringfeder.com