

KATALOG



VERBINDUNGSTECHNIK



WILLKOMMEN IN DER CAMOZZI WELT

Camozzi Automation bietet Komponenten, Systeme und Technologien der Antriebs- und Fluidtechnik für die Bereiche Industrial Automation, Transportation und Life Science.

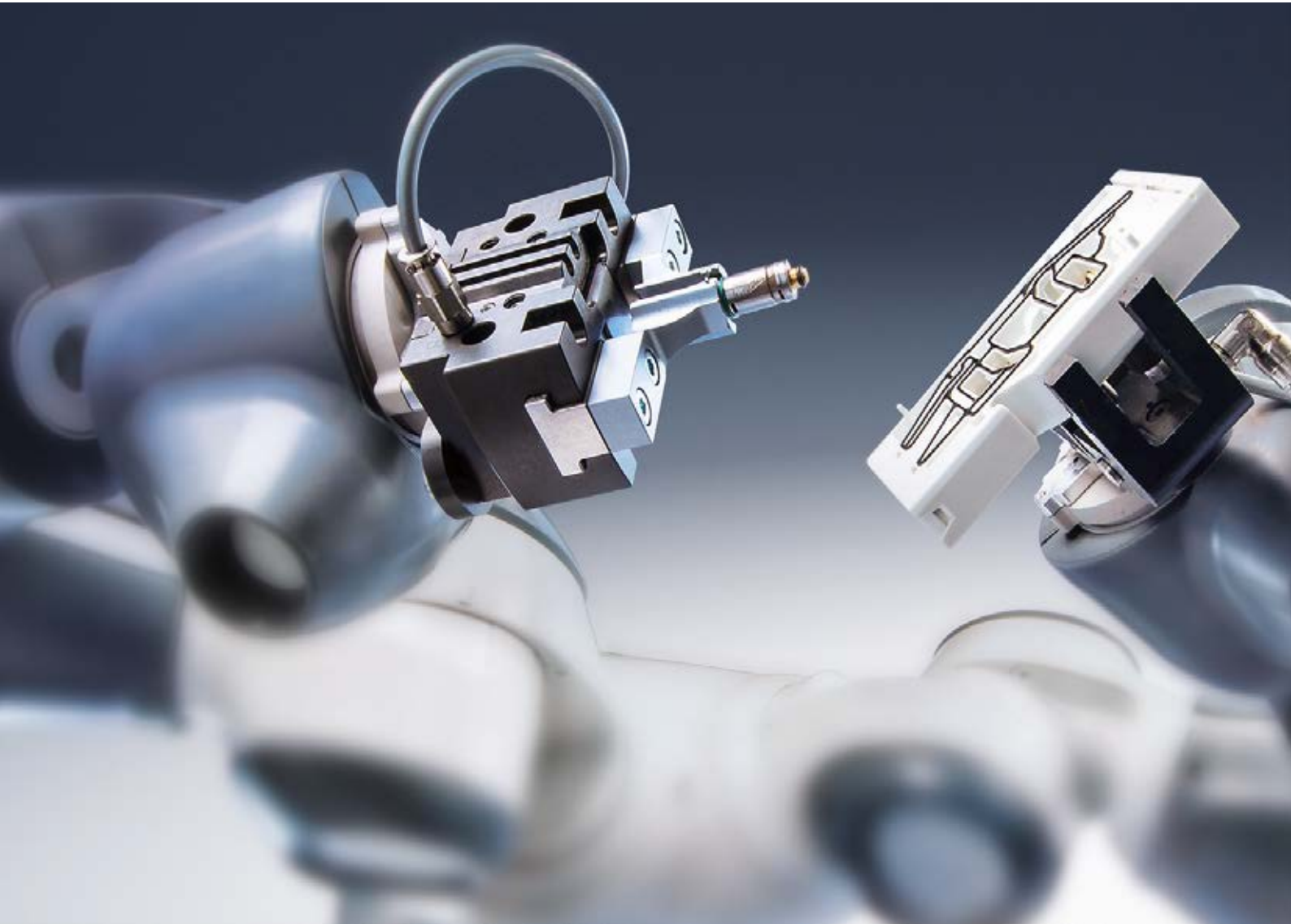

Kontakt



Camozzi Automation GmbH
Porschestraße 1
D-73095 Albershausen
Tel. +49 7161 91010-0
info@camozzi.de
www.camozzi.de



Camozzi Automation GmbH
Löfflerweg 18
A-6060 Hall in Tirol
Tel. +43 5223 52888-0
info@camozzi.at
www.camozzi.at

Unsere Kataloge

1 Pneumatische Antriebe



- 1 Normzylinder und Linearführungen
- 2 Kompaktzylinder
- 3 Edelstahlzylinder
- 4 Führungseinheiten
- 5 Nicht genormte Zylinder
- 6 Drehzylinder
- 7 Kolbenstangenlose Zylinder
- 8 Schaltelemente
- 9 Ölbremiszylinder, Feststelleinheiten, Stoßdämpfer

2 Elektrische Antriebe



- 1 Elektrozyylinder
- 2 Linearantriebe
- 3 Antriebsverstärker und Software
- 4 Motoren und Getriebe

3 Handling



- 1 Greifer

4 Vacuum



- 1 Sauggreifer
- 2 Ejektoren
- 3 Vakuum-Zubehör
- 4 Vakuum-Filter

5 Ventile und Magnetventile



- 1 2/2-, 3/2-Wegeventile, vorgesteuert oder direktgesteuert
- 2 Magnetventile, pneumatisch betätigte Wegeventile, Batterieversion
- 3 Wegeventile, mechanisch und manuell betätigt
- 4 Logikventile
- 5 Stop-/Sperr-, Schnellentlüftungsventile
- 6 Strom- und Sperrventile
- 7 Schalldämpfer

6 Ventilinsein und Feldbus-Module



- 1 Ventilinsein
- 2 Feldbus-Module

7 Proportionaltechnik



- 1 Proportionalventile
- 2 Proportionalregler

8 Druckluftaufbereitung



- 1 Druckluftaufbereitung Serie MX
- 2 Druckluftaufbereitung Serie MC
- 3 Druckluftaufbereitung Serie MD
- 4 Druckluftaufbereitung Serie N
- 5 Druckregler
- 6 Druck-/Vakuumschalter
- 7 Zubehör zur Druckluftaufbereitung

9 Verbindungstechnik



- 1 Steckverschraubungen Superrapid
- 2 Schnellverschraubungen Rapid
- 3 Klemmringverschraubungen Universal
- 4 Verschraubungszubehör
- 5 Einhandkupplungen
- 6 Schläuche, Schlauchspiralen und Zubehör
- 7 Steckverschraubungen und Zubehör für Anwendungen mit medizinischen Gasen
- 8 Mini-Kugelhähne

Inhaltsverzeichnis

1 Steckverschraubungen Superrapid

	Kapitel	Seite
 Serie 6000 Steckverschraubungen Superrapid	1.05	1
 Serie 7000 Steckverschraubungen Superrapid aus Kunststoff	1.10	24
 Neu Serie 7000 Fluidics Steckverschraubungen Superrapid aus Kunststoff	1.12	37
 Serie 8000 Steckverschraubungen Dual Seal Superrapid	1.15	45
 Serie H8000 Steckverschraubungen Dual Seal Superrapid	1.16	48
 Serie X6000 Steckverschraubungen Superrapid aus Edelstahl 1.4404	1.25	51



2 Schnellverschraubungen Rapid

	Kapitel	Seite
 Serie 1000 Schnellverschraubungen Rapid	2.05	58

3 Klemmringverschraubungen Universal

	Kapitel	Seite
 Serie 1000 Klemmringverschraubungen Universal	3.05	71

4 Verschraubungszubehör

	Kapitel	Seite
 Serie S2000 Verschraubungszubehör Sprint®	4.05	77
 Serie 2000 Verschraubungszubehör	4.10	83

5 Einhandkupplungen

	Kapitel	Seite
 Serie 5000 Einhandkupplungen	5.05	97
 Serie 5000L, 5000LT Einhandkupplungen für Heizkreisläufe von Gussformen	5.06	103

6 Schläuche, Schlauchspiralen und Zubehör

	Kapitel	Seite
 Schläuche, Schlauchspiralen und Zubehör	6.05	106

7 Steckverschraubungen und Zubehör für Anwendungen mit medizinischen Gasen

	Kapitel	Seite
 Neu Steckverschraubungen und Zubehör für Anwendungen mit medizinischen Gasen	7.05	110

8 Mini-Kugelhähne

	Kapitel	Seite
 Neu Serie 29 2/2-Wege Mini-Kugelhähne	8.01	122

Steckverschraubungen Superrapid Serie 6000

Durchmesser: \varnothing 3, 4, 5, 6, 8, 10, 12, 14, 16 mm
Anschlüsse: M3, M5, M6, M7, G1/8", G1/4", G3/8", G3/4", G1/2",
R1/8", R1/4", R3/8", R1/2"

STECKVERSCHRAUBUNGEN SUPERRAPID SERIE 6000



Die Spannzange der Steckverschraubungen Superrapid Serie 6000 wurde mit den Anforderungen entwickelt, eine homogene Dichtigkeit auf der gesamten Oberfläche von Kunststoffschläuchen zu gewährleisten. Diese Eigenschaft garantiert eine hohe Zuverlässigkeit und lange Lebensdauer, auch nach mehrmaliger Montage und Demontage des Schlauchs.

Es sind unterschiedliche Gewindeausführungen erhältlich: metrisch, BSP und BSPT.

Die Sprint®-Serie mit patentiertem System hat die Eigenschaft, auch bei unebenen Oberflächen verschraubt werden zu können. Möglich wird dies durch einen Teflon Ring am Außengewinde, der eine hervorragende Abdichtung garantiert.

Die große Bandbreite an Verschraubungen beinhaltet außerdem die LF Version (Stopp-Verschraubungen). Diese Verschraubungen haben ein Rückschlagventil. Es unterbricht den Durchfluss beim Lösen des Schlauches und gibt ihn beim Stecken wieder frei.

ALLGEMEINE KENNGRÖSSEN

Durchmesser	6000 Micro: \varnothing 3, 4, 6, 8, 10 mm; 6000: \varnothing 4, 16 mm
Gewinde	6000 Micro: M3, M5, M7, G1/8", G1/4" 6000: R konisch ISO 7 (BSPT), G zylindrisch ISO 228 (BSP) M5, M6, andere auf Anfrage NPT auf Anfrage
Betriebstemperatur	6000 Micro: -10°C ÷ 80°C (schlauch- und druckabhängig) 6000: -20°C ÷ 80°C (schlauch- und druckabhängig)
Werkstoffe Schlauch	Polyamid 6 - 11 - 12, Polyethylen, Polyurethan, Thermoplastisches Polyester-Elastomer
Medium	Druckluft (andere Medien auf Anfrage)
Werkstoffe	Körper + Zange Messing vernickelt, O-Ring NBR, Gewindedichtung PTFE-NBR-Polyamid
Betriebsdruck	-0,9 ÷ 16 bar (schlauchabhängig)

Funktionsprinzip

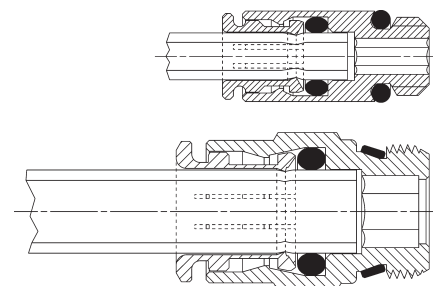

Gerade Einschraub-Verschraubung Mod. S6510

Sprint®, zylindrisch

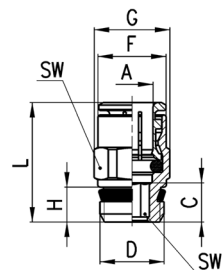

PRODUKTÜBERSICHT										
Mod.	A	D	C	F	G	H	L	SW	SW1	Gewicht (g)
S6510 4-1/8	4	G1/8	3.8	8.8	13.2	5.5	18	12	2.5	9
S6510 4-1/4	4	G1/4	5.5	8.8	15.2	7	19.5	14	2.5	15
S6510 5-1/8	5	G1/8	3.8	9.8	13.2	5.5	19	12	3	8
S6510 5-1/4	5	G1/4	5.5	9.8	15.2	7	20	14	3	14
S6510 6-1/8	6	G1/8	6	11.7	13.2	5.5	22	12	4	10
S6510 6-1/4	6	G1/4	5.5	11.7	15.2	7	21	14	4	14
S6510 6-3/8	6	G3/8	6.5	11.7	20.5	8	22.5	19	4	27
S6510 8-1/8	8	G1/8	7.5	13.7	15.2	5.5	25	14	5	13
S6510 8-1/4	8	G1/4	6.5	13.7	15.2	7	24	14	6	14
S6510 8-3/8	8	G3/8	6	13.7	20.5	8	23.5	19	6	25
S6510 8-1/2	8	G1/2	7.5	13.7	24.5	9	25	22	6	43
S6510 10-1/4	10	G1/4	8.3	15.4	18.5	7	28.5	17	7	23
S6510 10-3/8	10	G3/8	5.3	15.4	20.5	8	25.5	19	8	27
S6510 10-1/2	10	G1/2	4.8	16	24.5	9	25	22	8	39
S6510 12-1/4	12	G1/4	10.3	18.3	20.5	7	29.5	19	7	26
S6510 12-3/8	12	G3/8	9.3	18.3	20.5	8	28.5	19	9	30
S6510 12-1/2	12	G1/2	5.8	18.3	24.5	9	25	22	10	36
S6510 14-3/8	14	G3/8	10.3	20.5	24.5	8	30.5	22	9	42
S6510 14-1/2	14	G1/2	6.3	20.5	24.5	9	26.5	22	12	34
S6510 16-1/2	16	G1/2	9	23.5	26.5	9	32	24	-	42
S6510 16-3/4	16	G3/4	3.5	23.5	27.3	9	26.5	24	-	46

Gerade Einschraub-Verschraubung Mod. S6510...-LF



Sprint®, zylindrisch, mit integriertem Rückschlagventil

Diese Stopp-Verschraubungen haben ein Rückschlagventil. Es unterbricht den Durchfluss beim Lösen des Schlauches und gibt ihn beim Stecken wieder frei.

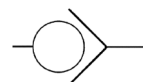
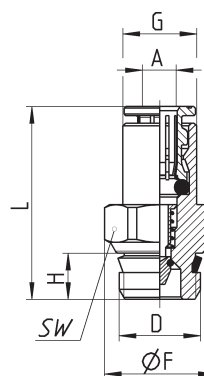

PRODUKTÜBERSICHT								
Mod.	A	D	F	G	H	L	SW	Gewicht (g)
S6510 4-1/8-LF	4	G1/8	13.2	8.8	5.5	23	12	11
S6510 6-1/8-LF	6	G1/8	13.2	11.7	6	30.5	12	15

Gerade Einschraub-Verschraubung Mod. 6512 Micro



Mit O-Ring/Dichtring montiert, zylindrisch
Kompakte Ausführung, mit Innensechskant

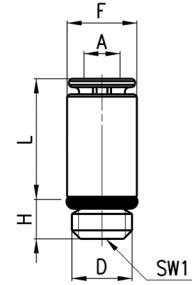

PRODUKTÜBERSICHT								
Mod.	A	D	F	H	L	SW1	Gewicht (g)	
6512 3-M3	3	M3	5.8	2.5	10.2	1.5	1	*
6512 3-M5	3	M5	5.8	3.5	10	2	1	•
6512 4-M7-M	4	M7	9.4	5	17.5	2.5	5	•
6512 4-1/8-M	4	G1/8	11.2	5	13	2.5	9	•, Y
6512 6-M7-M	6	M7	10.4	5	17	4	7	•
6512 6-1/8-M	6	G1/8	11.2	5	14	4	7	•, Y
6512 8-1/8-M	8	G1/8	12.4	5	18.5	5	10	•, Y
6512 10-1/4-M	10	G1/4	14.8	6	21	7	16	•

* = mit Dichtring montiert
• = mit O-Ring montiert
Y = verwendbar für Ventilinsel Serie Y

Gerade Einschraub-Verschraubungen Mod. 6512

Neue Modelle



Mit O-Ring montiert, zylindrisch

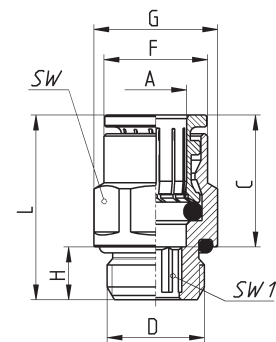

PRODUKTÜBERSICHT										
Mod.	A	D	C	F	G	H	L	SW	SW1	Gewicht (g)
6512 4-M5	4	M5	14.0	7.8	8.8	4	20	8	2	4
6512 4-M6	4	M6	14.0	8.8	9.9	4.5	20.5	9	2.5	6
6512 4-1/8	4	G1/8	14.0	8.8	13.5	6	19	12	2.5	10
6512 4-1/4	4	G1/4	14.0	8.8	16.4	7	20.5	15	2.5	14
6512 5-M5	5	M5	15.0	8.8	9.9	4	21	9	2	5
6512 6-M5	6	M5	16.0	11.7	13.2	4	22	12	2	8
6512 6-M6	6	M6	16.0	11.7	13.2	4.5	22.5	12	2.5	8
6512 6-1/8	6	G1/8	16.0	11.7	13.5	6	21	12	4	10
6512 6-1/4	6	G1/4	16.0	11.7	16.4	7	22	15	4	13
6512 8-1/8	8	G1/8	17.5	13.7	15.2	6	26	14	5	15
6512 8-1/4	8	G1/4	17.5	13.7	16.4	7	24.5	15	6	17
6512 8-3/8	8	G3/8	17.5	13.7	20.5	7	23	19	6	27
6512 10-1/4	10	G1/4	20.2	15.4	18.5	7	30	17	7	26
6512 10-3/8	10	G3/8	20.2	15.4	20.5	7	24.5	19	8	27
6512 10-1/2	10	G1/2	20.2	15.4	24.8	8	25	22	8	39
6512 12-1/4	12	G1/4	19.2	18.3	20.5	7	29.5	19	7	29
6512 12-3/8	12	G3/8	19.2	18.3	20.5	7	24	19	9	24
6512 12-1/2	12	G1/2	19.2	18.3	24.8	8	24.5	22	9	37
6512 14-3/8	14	G3/8	20.2	20.5	24.5	7	30.5	22	10	38
6512 14-1/2	14	G1/2	20.2	20.5	24.8	8	25.5	22	10	35
6512 16-1/2	16	G1/2	23.0	23.5	26.5	8	33.5	24	-	49

Gerade Aufschraub-Verschraubung Mod. 6463

Zylindrisch

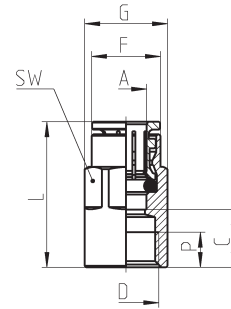

PRODUKTÜBERSICHT									
Mod.	A	D	C	F	G	L	P (min)	SW	Gewicht (g)
6463 4-M5	4	M5	6.5	7.8	8.8	20.5	4.5	9	8
6463 4-1/8	4	G1/8	10	9	13	24	6	12	14
6463 5-1/8	5	G1/8	10	9.8	13	25	6	12	14
6463 6-1/8	6	G1/8	10	11.7	13	26	6	12	14
6463 6-1/4	6	G1/4	11.5	11.9	16.5	27.5	7	15	23
6463 8-1/8	8	G1/8	9.5	13.7	15.2	27	6	14	16
6463 8-1/4	8	G1/4	11.5	13.7	16.5	29	7	15	23
6463 10-1/4	10	G1/4	11.3	15.4	18.5	31.5	7	17	29

Winkel-Einschraub-Verschraubung Mod. S6520

Sprint®, zylindrisch, drehbar

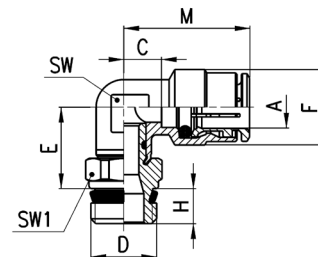

PRODUKTÜBERSICHT										
Mod.	A	D	C	E	F	H	M	SW	SW1	Gewicht (g)
S6520 4-1/8	4	G1/8	3.5	14.5	9	5.5	17.5	8	12	17
S6520 4-1/4	4	G1/4	3.5	14.5	9	7	17.5	8	14	23
S6520 5-1/8	5	G1/8	5.5	14.5	10	5.5	20.5	9	12	17
S6520 5-1/4	5	G1/4	5.5	14.5	10	7	20.5	9	14	23
S6520 6-1/8	6	G1/8	4	15	12.7	5.5	20	9	12	20
S6520 6-1/4	6	G1/4	4	15	12.7	7	20	9	14	23
S6520 6-3/8	6	G3/8	4	15.5	12.7	8	20	9	19	33
S6520 8-1/8	8	G1/8	5	16	14.2	5.5	22.5	11	12	22
S6520 8-1/4	8	G1/4	5	16	14.2	7	22.5	11	14	26
S6520 8-3/8	8	G3/8	5	16.5	14.2	8	22.5	11	19	41
S6520 8-1/2	8	G1/2	5	17	14.2	9	22.5	11	22	48
S6520 10-1/4	10	G1/4	5.8	18.5	16.5	7	26	13	14	32
S6520 10-3/8	10	G3/8	5.8	19	16.5	8	26	13	19	43
S6520 10-1/2	10	G1/2	5.8	19.5	16.5	9	26	13	22	62
S6520 12-1/4	12	G1/4	7.3	20	19.5	7	26.5	15	17	49
S6520 12-3/8	12	G3/8	7.3	20	19.5	8	26.5	15	19	48
S6520 12-1/2	12	G1/2	7.3	20.5	19.5	9	26.5	15	22	70
S6520 14-3/8	14	G3/8	8.3	21	21.5	8	28.5	17	19	74
S6520 14-1/2	14	G1/2	8.3	21.5	21.5	9	28.5	17	22	78

Winkel-Einschraub-Verschraubung Mod. 6522 Micro



Mit O-Ring/Dichtring montiert, zylindrisch, drehbar, kompakte Ausführung

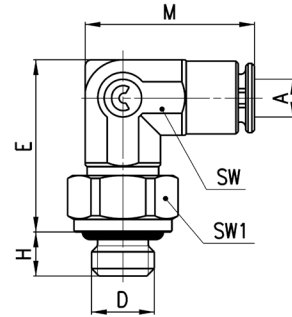

PRODUKTÜBERSICHT									
Mod.	A	D	E	H	M	SW	SW1	Gewicht (g)	
6522 3-M3	3	M3	13.7	2.5	13.7	6	6	4	*
6522 3-M5	3	M5	13.7	3.5	13.7	6	8	5	•

* = mit Dichtring montiert
• = mit O-Ring montiert

Winkel-Einschraub-Verschraubung Mod. 6522

Neue Modelle

Mit O-Ring montiert, zylindrisch, drehbar

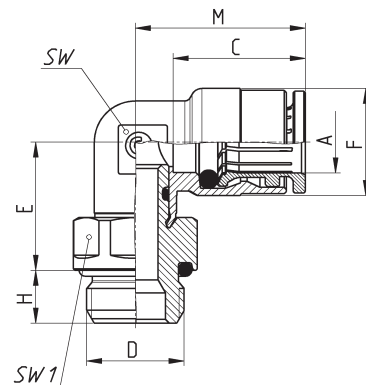

PRODUKTÜBERSICHT										
Mod.	A	D	C	E	F	H	M	SW	SW1	Gewicht (g)
6522 4-M5	4	M5	14.0	12.5	9	4	17.5	8	8	12
6522 4-1/8	4	G1/8	14.0	14.5	9	6	17.5	8	12	15
6522 4-1/4	4	G1/4	14.0	15.5	9	7	17.5	8	15	25
6522 5-M5	5	M5	15.0	12.5	10	4	20.5	9	8	13
6522 6-M5	6	M5	16.0	13	12.7	4	20	9	10	14
6522 6-1/8	6	G1/8	16.0	15	12.7	6	20	9	12	19
6522 6-1/4	6	G1/4	16.0	16	12.7	7	20	9	15	27
6522 8-1/8	8	G1/8	17.5	16	14.2	6	22.5	11	12	22
6522 8-1/4	8	G1/4	17.5	17	14.2	7	22.5	11	15	28
6522 8-3/8	8	G3/8	17.5	17	14.2	7	22.5	11	19	45
6522 10-1/4	10	G1/4	20.2	19.5	16.5	7	26	13	15	41
6522 10-3/8	10	G3/8	20.2	19.5	16.5	7	26	13	19	45
6522 10-1/2	10	G1/2	20.2	20.5	16.5	8	26	13	22	53
6522 12-1/4	12	G1/4	19.2	20	19.5	7	26.5	15	17	51
6522 12-3/8	12	G3/8	19.2	20.5	19.5	7	26.5	15	19	56
6522 12-1/2	12	G1/2	19.2	21.5	19.5	8	26.5	15	22	58
6522 14-3/8	14	G3/8	20.2	21.5	21.5	7	28.5	17	19	53
6522 14-1/2	14	G1/2	20.2	22.5	21.5	8	28.5	17	22	61

Winkel-Einschraub-Verschraubung Mod. S6500

Sprint®, konisch

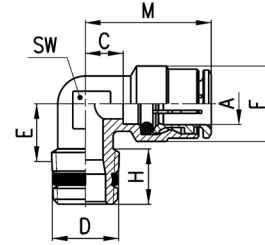

PRODUKTÜBERSICHT									
Mod.	A	D	C	E	F	H	M	SW	Gewicht (g)
S6500 4-1/8	4	R1/8	3.5	8.5	9	7.5	17.5	8	9
S6500 4-1/4	4	R1/4	5	11.5	9	12	19	9	13
S6500 5-1/8	5	R1/8	5.5	8.5	10	7.5	20.5	9	13
S6500 5-1/4	5	R1/4	5.5	11.5	10	12	20.5	9	17
S6500 6-1/8	6	R1/8	4	9	12.7	7.5	20	9	15
S6500 6-1/4	6	R1/4	4	11.5	12.7	12	20	9	16
S6500 8-1/8	8	R1/8	5	10.5	14.2	6.5	22.5	11	18
S6500 8-1/4	8	R1/4	5	11.5	14.2	12.5	22.5	11	21
S6500 8-3/8	8	R3/8	7	13	14.2	11.5	24.5	12	25
S6500 10-1/4	10	R1/4	5.8	13	16.5	11.5	26	13	33
S6500 10-3/8	10	R3/8	5.8	13	16.5	12	26	13	33
S6500 12-1/4	12	R1/4	7.3	14.5	19.5	11	26.5	15	46
S6500 12-3/8	12	R3/8	7.3	13.5	19.5	11.5	26.5	15	39

Winkel-Einschraub-Verschraubung Mod. 6525



Sprint®, zylindrisch, drehbar
Ermöglicht z. B. bei Ventilblöcken das parallele Verlegen von Rohren - kombiniert mit Mod. S6520

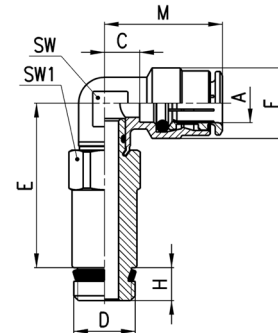

PRODUKTÜBERSICHT										
Mod.	A	D	C	E	F	H	M	SW	SW1	Gewicht (g)
6525 6-1/8	6	G1/8	4	33.8	12.7	5.5	20	9	12	34
6525 6-1/4	6	G1/4	4	34	12.7	7	20	9	14	47
6525 8-1/8	8	G1/8	5	34.8	14.2	5.5	22.5	11	12	35
6525 8-1/4	8	G1/4	5	35	14.2	7	22.5	11	14	50

Winkel-Einschraub-Verschraubung Mod. 6621 Micro



Mit Dichtring montiert, zylindrisch, kompakte Ausführung

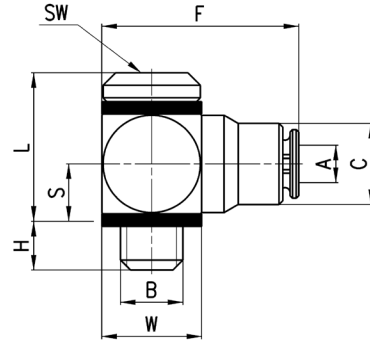

PRODUKTÜBERSICHT

Mod.	A	B	C	F	H	L	S	W	SW	Gewicht (g)
6621 3-M3	3	M3	5.8	14.2	2.5	9.3	3.5	6	1.5	5
6621 3-M5	3	M5	6.5	16	3.2	11.9	4.8	8	2	6

Winkel-Einschraub-Verschraubung Mod. 6501



Mit Dichtring montiert, zylindrisch

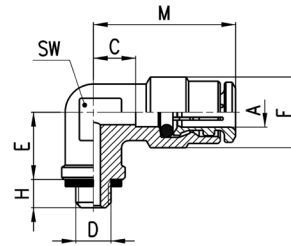

PRODUKTÜBERSICHT

Mod.	A	D	C	E	F	H	M	SW	Gewicht (g)
6501 4-M5	4	M5	3.5	6	9	4	17.5	8	11

T-Einschraub-Verschraubung Mod. S6430

Sprint®, zylindrisch, drehbar

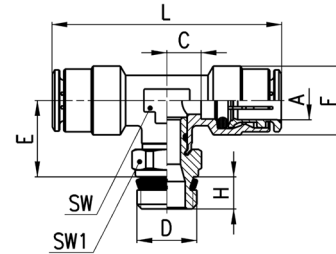

PRODUKTÜBERSICHT										
Mod.	A	D	C	E	F	H	L	SW	SW1	Gewicht (g)
S6430 4-1/8	4	G1/8	3.5	14.5	9	5.5	35	8	12	18
S6430 5-1/8	5	G1/8	5.5	14.5	10	5.5	41	9	12	24
S6430 5-1/4	5	G1/4	5.5	14.5	10	7	41	9	14	30
S6430 6-1/8	6	G1/8	4	15	12.7	5.5	40	9	12	28
S6430 6-1/4	6	G1/4	4	15	12.7	7	40	9	14	33
S6430 8-1/8	8	G1/8	5	16	14.2	5.5	45	11	12	37
S6430 8-1/4	8	G1/4	5	16	14.2	7	45	11	14	42
S6430 8-3/8	8	G3/8	5	16.5	14.2	8	45	11	19	51
S6430 10-1/4	10	G1/4	5.8	18.5	16.5	7	52	13	14	56
S6430 10-3/8	10	G3/8	5.8	19	16.5	8	52	13	19	67
S6430 10-1/2	10	G1/2	5.8	19.5	16.5	9	52	13	22	85
S6430 12-1/4	12	G1/4	7.3	20	19.5	7	53	15	17	60
S6430 12-3/8	12	G3/8	7.3	20	19.5	8	53	15	19	65
S6430 12-1/2	12	G1/2	7.3	20.5	19.5	9	53	15	22	89
S6430 14-1/2	14	G1/2	8.3	21.5	21.5	9	57	17	22	88

T-Einschraub-Verschraubung Mod. 6432 Micro

Mit O-Ring/Dichtring montiert, zylindrisch, drehbar, kompakte Ausführung

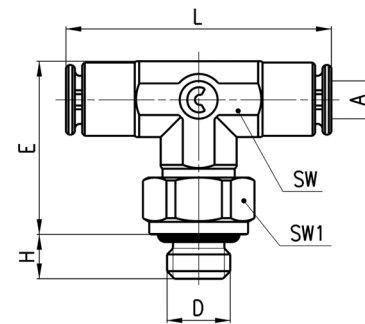

PRODUKTÜBERSICHT									
Mod.	A	D	E	H	L	SW	SW1	Gewicht (g)	
6432 3-M3	3	M3	13.7	2.5	21.4	6	6	5	*
6432 3-M5	3	M5	13.7	3.5	21.4	6	8	6	•

• = mit O-Ring montiert
* = mit Dichtring montiert

T-Einschraub-Verschraubung Mod. 6432

Mit O-Ring montiert, zylindrisch, drehbar

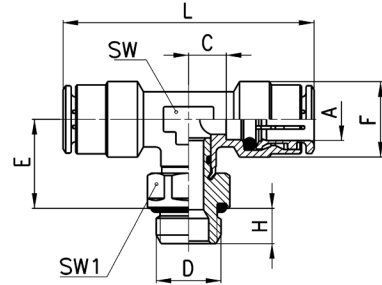

PRODUKTÜBERSICHT										
Mod.	A	D	C	E	F	H	L	SW	SW1	Gewicht (g)
6432 4-M5	4	M5	3.5	12.5	9	4	35	8	8	14
6432 4-1/8	4	G1/8	3.5	14.5	9	6	35	8	12	19
6432 5-M5	5	M5	5.5	12.5	10	4	41	9	8	19
6432 6-1/8	6	G1/8	4	15	12.7	6	40	9	12	29
6432 6-1/4	6	G1/4	4	16	12.7	7	40	9	15	30
6432 8-1/8	8	G1/8	5	16	14.2	6	45	11	12	37
6432 8-1/4	8	G1/4	5	17	14.2	7	45	11	15	39
6432 8-3/8	8	G3/8	5	17	14.2	7	45	11	19	55
6432 10-1/4	10	G1/4	5.8	19.5	16.5	7	52	13	15	59
6432 10-3/8	10	G3/8	5.8	19.5	16.5	7	52	13	19	56
6432 12-1/4	12	G1/4	7.3	20	19.5	7	53	15	17	60
6432 12-3/8	12	G3/8	7.3	20.5	19.5	7	53	15	19	80

L-Einschraub-Verschraubung Mod. S6440

Sprint®, zylindrisch, drehbar

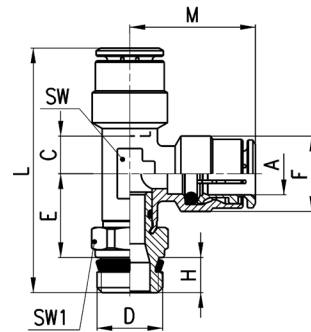

PRODUKTÜBERSICHT											
Mod.	A	D	C	E	F	H	L	M	SW	SW1	Gewicht (g)
S6440 4-1/8	4	G1/8	3.5	14.5	9	5.5	37.5	17.5	8	12	23
S6440 5-1/8	5	G1/8	5.5	14.5	10	5.5	40.5	20.5	9	12	24
S6440 6-1/8	6	G1/8	4	15	12.7	5.5	40.5	20	9	12	26
S6440 6-1/4	6	G1/4	4	15	12.7	7	42	20	9	14	31
S6440 8-1/8	8	G1/8	5	16	14.2	5.5	44	22.5	11	12	37
S6440 8-1/4	8	G1/4	5	16	14.2	7	45.5	22.5	11	14	35
S6440 8-3/8	8	G3/8	5	16.5	14.2	8	47	22.5	11	19	52
S6440 10-1/4	10	G1/4	5.8	18.5	16.5	7	51.5	26	13	14	43
S6440 10-3/8	10	G3/8	5.8	18.5	16.5	8	53	26	13	19	66
S6440 12-3/8	12	G3/8	7.3	19.5	19.5	8	54.5	26.5	15	19	65
S6440 14-1/2	14	G1/2	8.3	21.5	21.5	9	59	28.5	17	22	88

L-Einschraub-Verschraubung Mod. 6442 Micro



Mit O-Ring/Dichtring montiert, zylindrisch, drehbar, kompakte Ausführung

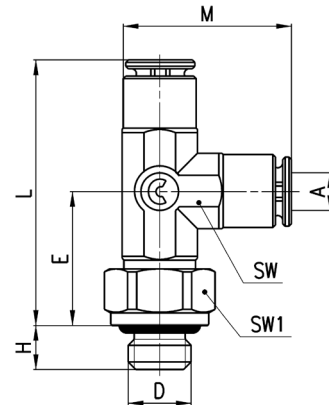

PRODUKTÜBERSICHT										
Mod.	A	D	E	H	L	M	SW	SW1	Gewicht (g)	
6442 3-M3	3	M3	10.7	2.5	21.4	13.7	6	6	5	*
6442 3-M5	3	M5	12.2	3.5	21.4	13.7	6	8	6	•

• = mit O-Ring montiert
* = mit Dichtring montiert

L-Einschraub-Verschraubung Mod. 6442



Mit O-Ring montiert, zylindrisch, drehbar

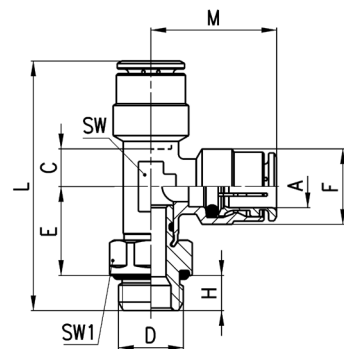

PRODUKTÜBERSICHT											
Mod.	A	D	C	E	F	H	L	M	SW	SW1	Gewicht (g)
6442 4-M5	4	M5	3.5	12.5	9	4	34	17.5	8	8	18
6442 4-1/8	4	G1/8	3.5	14.5	9	6	38	17.5	8	12	19
6442 5-M5	5	M5	5.5	12.5	10	4	36.5	20.5	9	8	19
6442 6-1/8	6	G1/8	4	15	12.7	6	41	20	9	12	26
6442 6-1/4	6	G1/4	4	16	12.7	7	43	20	9	15	36
6442 8-1/8	8	G1/8	5	16	14.2	6	44.5	22.5	11	12	31
6442 8-1/4	8	G1/4	5	17	14.2	7	46.5	22.5	11	15	42
6442 8-3/8	8	G3/8	5	17	14.2	7	46.5	22.5	11	19	50
6442 10-1/4	10	G1/4	5.8	19.5	16.5	7	52.5	26	13	15	46
6442 10-3/8	10	G3/8	5.8	19.5	16.5	7	52.5	26	13	19	66
6442 12-1/4	12	G1/4	7.3	20	16.5	7	53.5	26.5	15	17	73
6442 12-3/8	12	G3/8	7.3	20.5	19.5	7	54	26.5	15	19	64

Y-Einschraub-Verschraubung Mod. 6452 Micro



Mit O-Ring/Dichtring montiert, zylindrisch, drehbar, kompakte Ausführung

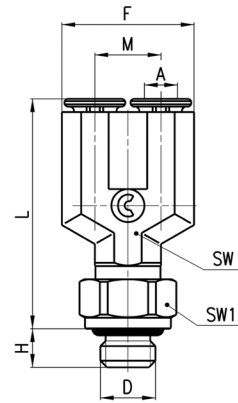

PRODUKTÜBERSICHT										
Mod.	A	D	F	H	L	M	SW	SW1	Gewicht (g)	
6452 3-M3	3	M3	12	2.5	20.9	6	6	6	6	*
6452 3-M5	3	M5	12	3.5	20.9	6	6	8	7	•

• = mit O-Ring montiert
* = mit Dichtring montiert

Y-Einschraub-Verschraubung Mod. 6451 + S6450



Mod. 6451: Mit Dichtring montiert, zylindrisch, kompakte Ausführung

Mod. S6450: Sprint®, zylindrisch, drehbar

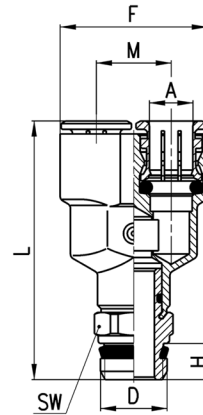

PRODUKTÜBERSICHT								
Mod.	A	D	F	H	L	M	SW	Gewicht (g)
6451 4-M5	4	M5	18	4	26.5	9	-	17 *
6451 6-M5	6	M5	24.5	4	29.5	12.5	-	27 *
S6450 4-1/8	4	G1/8	18	5.5	38	9	12	23
S6450 6-1/8	6	G1/8	24.5	5.5	41.5	12.5	12	33
S6450 8-1/8	8	G1/8	28.5	5.5	48.5	14.5	14	48
S6450 8-1/4	8	G1/4	28.5	7	50	14.5	14	50

* = Mod. nicht drehbar, mit Dichtring montiert

Winkel-Einschraub-Verschraubung Mod. 6622

Mit O-Ring montiert, zylindrisch, drehbar

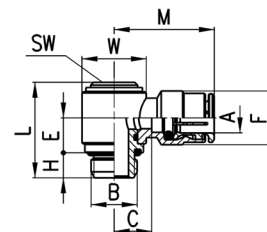

PRODUKTÜBERSICHT											
Mod.	A	B	C	E	F	H	L	M	SW	W	Gewicht (g)
6622 4-M5	4	M5	4	5.7	8.8	4	15.8	18	2.5	Ø 8	10 *
6622 4-1/8	4	G1/8	7.5	10.2	9	5	25	21.5	4	Ø 14	22
6622 6-1/8	6	G1/8	8	10.2	12.7	5	25	24	4	Ø 14	24
6622 6-1/4	6	G1/4	10	9.1	12.7	6	25.3	26	5	Ø 18	35
6622 8-1/8	8	G1/8	8	10.2	14.2	5	25	25.5	4	Ø 14	28
6622 8-1/4	8	G1/4	10	9.1	14.2	6	25.3	27.5	5	Ø 18	39
6622 10-1/4	10	G1/4	8.8	9.1	16.5	6	25.3	29	5	Ø 18	42

* metrisch, drehbar

T-Einschraub-Verschraubung Mod. 6632

Mit O-Ring montiert, zylindrisch, drehbar

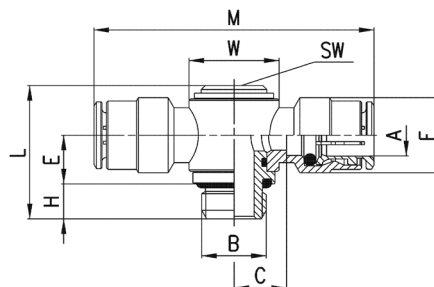

PRODUKTÜBERSICHT											
Mod.	A	B	C	E	F	H	L	M	W	SW	Gewicht (g)
6632 4-1/8	4	G1/8	7.5	10.2	9	5	25	43	∅ 14	4	24
6632 6-1/8	6	G1/8	8	10.2	12.7	5	25	48	∅ 14	4	33
6632 6-1/4	6	G1/4	10	9.1	12.7	6	25.3	52	∅ 18	5	35
6632 8-1/8	8	G1/8	8	10.2	14.2	5	25	51	∅ 14	4	39
6632 8-1/4	8	G1/4	10	9.1	14.2	6	25.3	55	∅ 18	5	40
6632 10-1/4	10	G1/4	8.8	9.1	16.5	6	25.3	58	∅ 18	5	50

T-Schwenkringstück Mod. 6620

Kombinierbar mit Hohlschrauben Mod. 1631/1635

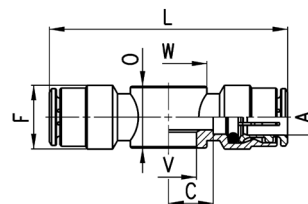

PRODUKTÜBERSICHT										
Mod.	A	C	F	L	O	V	W	Gewicht (g)	Kombinierbar mit Mod.	
6620 4-M5	4	5	9	38	9	5.1	∅ 9	13	SCU, SVU, SCO...	
6620 4-1/8	4	7.5	9	43	14.5	9.8	∅ 14	19	1631, 1635, SCU, SVU, SCO...	
6620 6-1/8	6	8	12.7	48	14.5	9.8	∅ 14	24	1631, 1635, SCU, SVU, SCO...	
6620 6-1/4	6	10	12.7	52	14.5	13.2	∅ 18	26	1631, 1635, SCU, SVU, SCO...	
6620 8-1/8	8	8	14.2	51	14.5	9.8	∅ 14	32	1631, 1635, SCU, SVU, SCO...	
6620 8-1/4	8	10	14.2	55	14.5	13.2	∅ 18	34	1631, 1635, SCU, SVU, SCO...	

Hohlschraube kurz Mod. 1631

- 01 = 1-fach
- 02 = 2-fach
- 03 = 3-fach

Mit Dichtring montiert



Mod.
1631 01-
1631 02-
1631 03-

Code und Maße finden Sie auf Seite 4.2.05.09

Schwenkringstück Mod. 6610

Kombinierbar mit Hohlschrauben Mod. 1631/1635

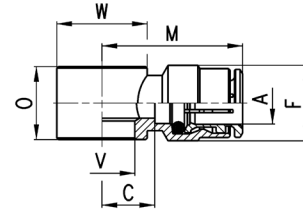

PRODUKTÜBERSICHT										
Mod.	A	C	F	M	O	V	W	Gewicht(g)	Kombinierbar mit Mod.	
6610 4-M5	4	5	9	19	9	5.1	9	9	1631	
6610 4-M6	4	5	9	19	9	5.1	9	8	SCU, SVU, SCO...	
6610 4-1/8	4	7.5	9	21.5	14.5	9.8	∅ 14	14	1631, 1635, SCU, SVU, SCO...	
6610 5-M5	5	5	10	20	9	5.1	9	9	1631	
6610 5-M6	5	5	10	20	9	5.1	9	8	SCU, SVU, SCO...	
6610 5-1/8	5	8	10	23	14.5	9.8	∅ 14	16	1631, 1635, SCU, SVU, SCO...	
6610 6-M5	6	6.5	12.7	22.5	9	5.1	∅ 10	12	1631	
6610 6-M6	6	6.5	12.7	22.5	9	5.1	∅ 10	12	SCU, SVU, SCO...	
6610 6-1/8	6	8	12.7	24	14.5	9.8	∅ 14	16	1631, 1635, SCU, SVU, SCO...	
6610 6-1/4	6	10	12.7	26	14.5	13.2	∅ 18	19	1631, 1635, SCU, SVU, SCO...	
6610 8-1/8	8	8	14.2	25.5	14.5	9.8	∅ 14	19	1631, 1635, SCU, SVU, SCO...	
6610 8-1/4	8	10	14.2	27.5	14.5	13.2	∅ 18	22	1631, 1635, SCU, SVU, SCO...	
6610 8-3/8	8	11	14.2	28.5	14.5	16.7	∅ 21	23	1631, 1635, SCU, SVU, SCO...	
6610 10-1/4	10	8.8	16.5	29	14.5	13.2	∅ 18	22	1635, SCU, SVU, SCO...	
6610 10-3/8	10	10.3	16.5	30.5	14.5	16.7	∅ 21	23	1635, SCU, SVU, SCO...	
6610 12-1/2	12	12,8	16,5	32	14,5	21	∅ 26	37	1635	

STECKVERSCHRAUBUNGEN SUPERRAPID SERIE 6000

Gewinde-Stecknippel Mod. 6811

Sprint®, zylindrisch

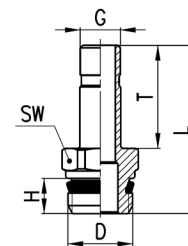

PRODUKTÜBERSICHT							
Mod.	G	D	H	T	L	SW	Gewicht (g)
6811 4-M5	4	M5	4	16.5	24.5	8	3 *
6811 4-1/8	4	G1/8	5.5	16.5	27.8	12	10
6811 5-1/8	5	G1/8	5.5	18	29.3	12	9
6811 5-1/4	5	G1/4	7	18	31	14	11
6811 6-1/8	6	G1/8	5.5	18	29.3	12	10
6811 6-1/4	6	G1/4	7	18	31	14	12
6811 8-1/8	8	G1/8	5.5	20.5	31.8	12	12
6811 8-1/4	8	G1/4	7	20.5	33.5	14	13
6811 10-1/4	10	G1/4	7	23	36	14	16
6811 10-3/8	10	G3/8	8	23	37.3	19	25
6811 12-3/8	12	G3/8	8	24	38.3	19	25
6811 14-1/2	14	G1/2	9	28	44	22	39

* = mit O-Ring montiert

Winkel-Einschraub-Verschraubung 45° Mod. S6110



Sprint®, zylindrisch, drehbar

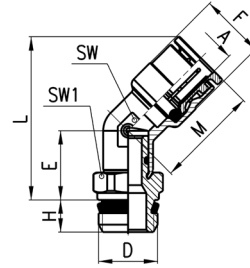

PRODUKTÜBERSICHT										
Mod.	A	D	E	F	H	L	M	SW	SW1	Gewicht(g)
S6110 6-1/8	6	G1/8	14	12.7	5.5	32.5	20.5	11	12	21
S6110 6-1/4	6	G1/4	14	12.7	7	34.5	20.5	11	14	25
S6110 8-1/8	8	G1/8	14	14.2	5.5	32.5	22.5	11	12	21
S6110 8-1/4	8	G1/4	14	14.2	7	34.5	22.5	11	14	26
S6110 8-3/8	8	G3/8	14.5	14.2	8	35	22.5	11	19	38
S6110 10-1/4	10	G1/4	15.5	16.5	7	39.5	26.5	15	17	39
S6110 10-3/8	10	G3/8	15.5	16.5	8	39.5	26.5	15	19	44
S6110 10-1/2	10	G1/2	16	16.5	9	40	26.5	15	22	57
S6110 12-1/4	12	G1/4	15.5	19.5	7	40.5	26.5	15	17	41
S6110 12-3/8	12	G3/8	15.5	19.5	8	40.5	26.5	15	19	46
S6110 12-1/2	12	G1/2	16	19.5	9	41	26.5	15	22	59

Gerade Schottverschraubung Mod. 6590 Micro

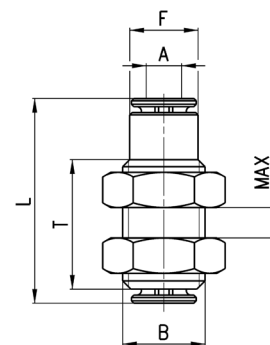
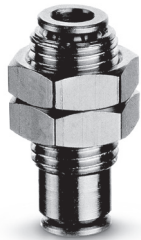

PRODUKTÜBERSICHT							
Mod.	A	B	F	L	MAX	T	Gewicht (g)
6590 3	3	M7x0.75	5.8	18.4	5	11.4	4

Gerade Schottverschraubung Mod. 6590

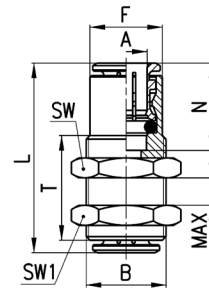

PRODUKTÜBERSICHT										
Mod.	A	B	F	L	N	MAX	SW	SW1	T	Gewicht (g)
6590 4	4	M10x1	8.8	29	14	10.5	14	14	20	16
6590 5	5	M12x1	9.8	31	15	10.5	17	17	20	25
6590 6	6	M14x1	12.5	33	16	10.5	17	17	20	28
6590 8	8	M16x1	14.5	36	17.5	11.5	19	19	21	35
6590 10	10	M18x1	16.3	41.5	20.2	13	22	22	23.5	51
6590 12	12	M20x1	18.8	39.5	19.2	14.5	24	24	25	56
6590 14	14	M22x1	20.5	41.5	20.2	17.5	27	27	30	82

Gerader Verbinder Mod. 6580 Micro



Für Schottmontage mit Seegerringen UNI 7435 und DIN 471

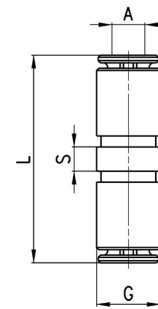

PRODUKTÜBERSICHT					
Mod.	A	G	L	S	Gewicht (g)
6580 3	3	5.8	19.9	2.2	2

Gerader Verbinder Mod. 6580



Für Schottmontage mit Seegerringen UNI 7434 und DIN 6799

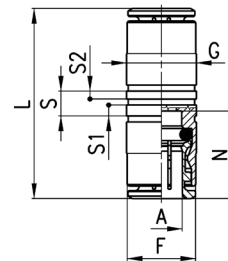

PRODUKTÜBERSICHT									
Mod.	A	F	G	L	N	S	S1	S2	Gewicht (g)
6580 4	4	8.4	9	29	14	5	2.2	1.6	11
6580 5	5	9.4	10	31	15	5	2.2	1.6	15
6580 6	6	11.7	12	34	16	5	2.2	1.6	16
6580 8	8	13.7	14	37	17.5	5	2.2	1.6	23
6580 10	10	15.4	17	41.5	20.2	5	2.2	1.6	33
6580 12	12	18.3	19	39.5	19.2	5.2	2.2	1.6	40
6580 14	14	20.5	21	41.5	20.2	5.2	2.2	1.6	47
6580 16	16	-	47	47	23	-	-	-	60

Gerader Reduzier-Verbinder Mod. 6580

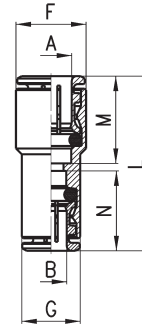

PRODUKTÜBERSICHT									
Mod.	A	B	F	G	L	M	N	Gewicht (g)	
6580 6-4	6	4	12	9	31.5	16	14	12	
6580 8-6	8	6	14	12.2	35	17.5	16	19	
6580 10-8	10	8	16	14	39	20	17.5	25	
6580 12-10	12	10	19	16	40.5	19	20	35	

Gerade Schott-Aufschraub-Verschraubung Mod. 6593

Zylindrisch

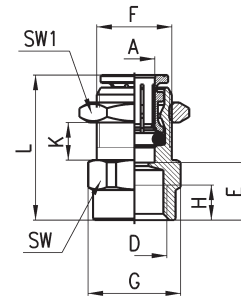

PRODUKTÜBERSICHT												
Mod.	A	D	E	F	G	H	L	K(max)	K(min)	SW	SW1	Gewicht (g)
6593 6-1/8	6	G1/8	10	M12x1	16.4	6	24.5	8.5	2	15	17	19
6593 6-1/4	6	G1/4	11.5	M12x1	18.5	7	26	6.5	2	17	17	22
6593 8-1/8	8	G1/8	10	M15x1	18.5	6	27	9.5	2	17	19	26
6593 8-1/4	8	G1/4	11.5	M15x1	18.5	7	28.5	9.5	2	17	19	26
6593 10-3/8	10	G3/8	12.8	M18x1	24.5	8	32.5	12	2	22	22	43

Winkel-Anschluss Mod. 6550 Micro

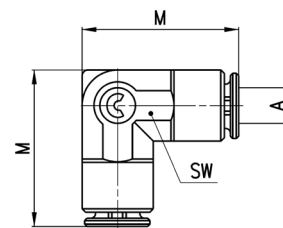

PRODUKTÜBERSICHT				
Mod.	A	M	SW	Gewicht (g)
6550 3	3	13.7	6	3

Winkel-Anschluss Mod. 6550

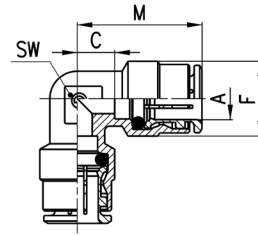

PRODUKTÜBERSICHT						
Mod.	A	C	F	M	SW	Gewicht (g)
6550 4	4	3.5	9	17.5	8	8
6550 5	5	5.5	10	20.5	9	15
6550 6	6	4	12.7	20	9	17
6550 8	8	5	14.2	22.5	11	22
6550 10	10	5.8	16.5	26	13	30
6550 12	12	7.3	19.5	26.5	15	44
6550 14	14	8.3	21.5	28.5	17	71

T-Anschluss Mod. 6540 Micro

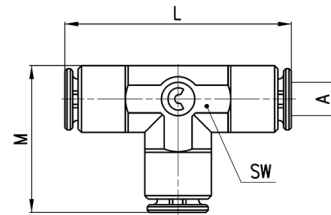

PRODUKTÜBERSICHT					
Mod.	A	L	M	SW	Gewicht (g)
6540 3	3	21.4	13.7	6	4

T-Anschluss Mod. 6540

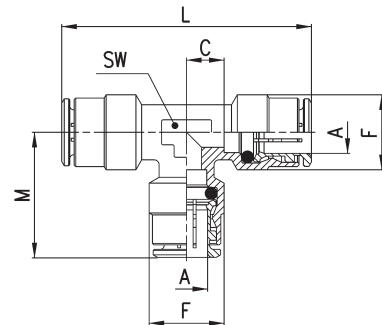

PRODUKTÜBERSICHT							
Mod.	A	C	F	L	M	SW	Gewicht (g)
6540 4	4	3.5	9	35	17.5	8	14
6540 5	5	5.5	10	41	20.5	9	21
6540 6	6	4	12.7	40	20	9	24
6540 8	8	5	14.2	45	22.5	11	32
6540 10	10	5.8	16.5	52	26	13	43
6540 12	12	7.3	19.5	53	26.5	15	60
6540 14	14	8.3	21.5	57	28.5	17	75

X-Anschluss Mod. 6600

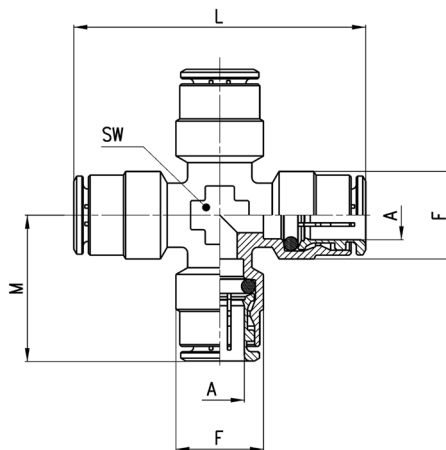

PRODUKTÜBERSICHT						
Mod.	A	F	L	M	SW	Gewicht (g)
6600 4	4	9	38	19	9	26
6600 5	5	10	41	20.5	9	29
6600 6	6	12.7	44	22	10	35
6600 8	8	14.2	49	24.5	12	50
6600 10	10	16.5	55	27.5	14	63
6600 12	12	19.5	56	28	16	84

Y-Anschluss Mod. 6560 Micro

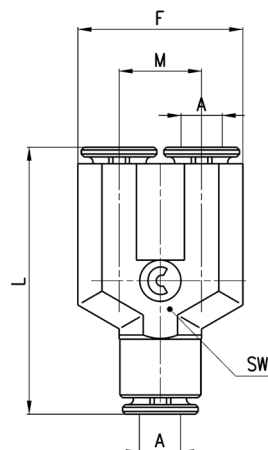
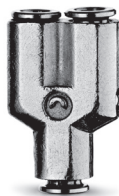

PRODUKTÜBERSICHT						
Mod.	A	F	L	M	SW	Gewicht (g)
6560 3	3	12	20.4	6	6	5

Y-Anschluss Mod. 6560

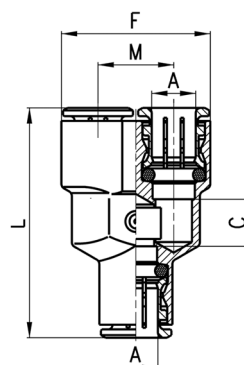

PRODUKTÜBERSICHT						
Mod.	A	C	F	L	M	Gewicht (g)
6560 4	4	5	18	33	9	19
6560 6	6	7	24.5	39	12.5	30
6560 8	8	9	28.5	44	14.5	42
6560 10	10	15.5	32	53.5	16	63

Einpress-Patrone Mod. 6700



S* = Bohrungsgeometrie Metall/
Kunststoff
siehe Einbaugeometrie rechts

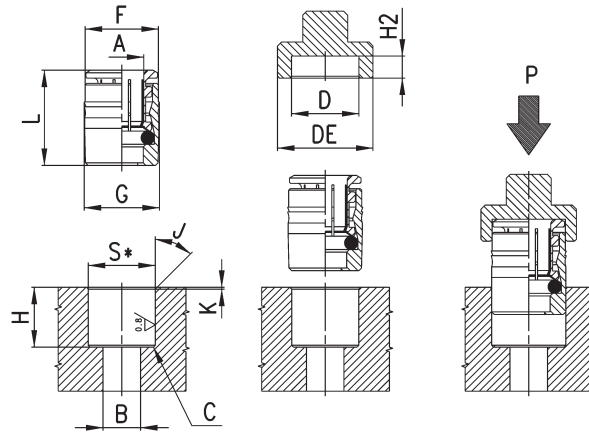

PRODUKTÜBERSICHT																
Mod.	A	B	C	D	DE	F	G	H	H2 (+0,1/0)	J	K	L	P min (Kg)	P max (Kg)	S (+0,01/-0,04)	Gewicht (g)
6700 3	3	2	0.5x45°	6.1	11	5.9	6.2	6.3	2.6	30°	0.3	9.2	80	350	6	1
6700 4	4	3.5	0.5x45°	8.8	14	8.6	9	11	3.3	15°	0.5	14.5	200	360	8.75	4
6700 5	5	3.5	0.5x45°	9.8	15	9.6	10	11.5	3.3	15°	0.5	15.5	230	450	9.75	5
6700 6	6	4	0.5x45°	12	17	11.8	12.2	12	3.8	15°	0.5	16.5	160	570	11.95	8
6700 8	8	6	0.5x45°	14	19	13.8	14.2	14	3.3	15°	0.5	18	140	400	13.95	11
6700 10	10	8	0.5x45°	16	21	15.8	16.2	16.5	3.5	15°	0.5	20.5	150	650	15.95	15

Einpress-Patrone Mod. 3053

Neu

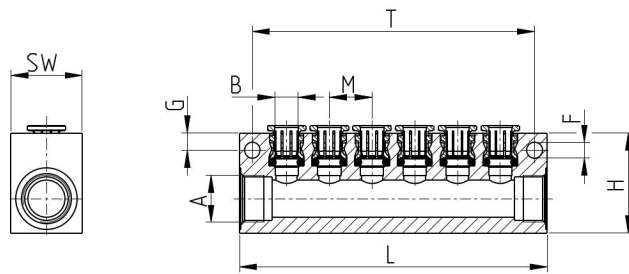

Mod.	A	ANZAHL ABGÄNGE	B	L	G	M	T	H	F	SW	Gewicht (g)
3053 1/4-8L-4	G1/4	8	4	97	4,5	10	88	30	4,5	20	140
3053 1/4-8L-6	G1/4	8	6	120	4,5	13	111	30	4,5	20	172
3053 3/8-6L-8	G3/8	6	8	108	6	15	99	35	5,5	25	210
3053 1/2-6L-10	G1/2	6	10	127	6,5	17	118	45	5,5	30	365

Verschluss-Stück Mod. 6750

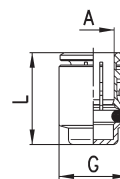

PRODUKTÜBERSICHT				
Mod.	A	G	L	Gewicht (g)
6750 4	4	8.8	15	4
6750 6	6	11.8	17	7
6750 8	8	13.8	18.5	9
6750 10	10	15.8	21	12
6750 12	12	17.8	20	15

Vergößerung Mod. 6850

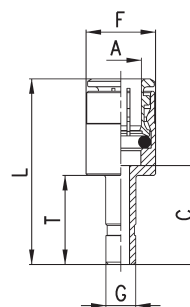

PRODUKTÜBERSICHT							
Mod.	A	G	C	F	L	T	Gewicht (g)
6850 6-4	6	4	17.5	12.7	33.5	16.5	11
6850 8-6	8	6	19	14	36.5	18	15

Reduzierung Mod. 6800 Micro

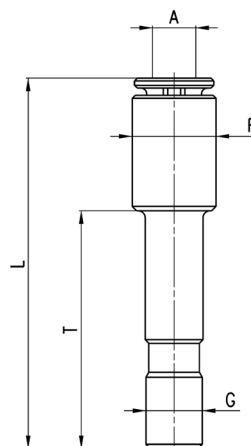

PRODUKTÜBERSICHT						
Mod.	A	F	G	L	T	Gewicht (g)
6800 3-4	3	5.8	4	26	16.5	2

Reduzierung Mod. 6800

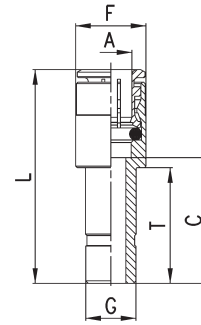

PRODUKTÜBERSICHT							
Mod.	A	G	C	F	L	T	Gewicht (g)
6800 4-5	4	5	19	9	33	18	8
6800 4-6	4	6	15.5	9	29.5	18	9
6800 4-8	4	8	18	9	32	20.5	10
6800 5-6	5	6	19	10	34	18	11
6800 5-8	5	8	18	10	33	20.5	12
6800 6-8	6	8	18	12.7	34	20.5	12
6800 6-10	6	10	20.5	12.7	36.5	23	17
6800 6-12	6	12	17.5	12.7	33.5	24	21
6800 8-10	8	10	20.5	14	38	23	15
6800 8-12	8	12	21.5	14	39	24	22
6800 10-12	10	12	20.3	16.5	40.5	24	27
6800 10-14	10	14	24.3	16.5	44.5	28	33
6800 12-14	12	14	24.3	18.8	45.5	28	27

Verbindungsstecker Mod. 6950

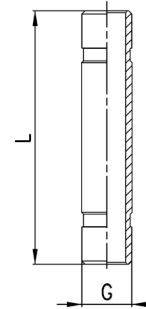

PRODUKTÜBERSICHT			
Mod.	G	L	Gewicht (g)
6950 4	4	32.5	3
6950 6	6	35.5	4
6950 8	8	40.5	7
6950 10	10	46	10
6950 12	12	48	13
6950 14	14	52	17

Winkelsteckanschluss Mod. 6555

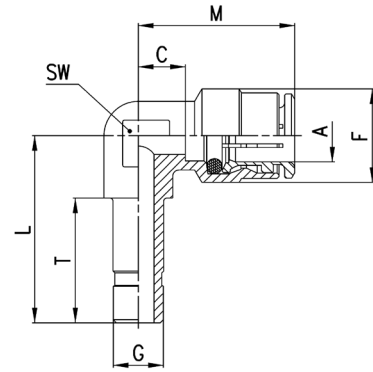

PRODUKTÜBERSICHT									
Mod.	A	G	C	L	F	T	M	SW	Gewicht (g)
6555 4-4	4	4	3.5	22	9	16.5	17.5	9	8
6555 6-6	6	6	4	24.5	12.7	18	20	9	14
6555 8-8	8	8	5	27.5	14.2	20	22.5	11	21
6555 10-10	10	10	5.8	32	16.5	23	26	13	26

Schutzkappe Mod. 6708



Farbe: schwarz,
Material: selbstlöschend
Klasse V0

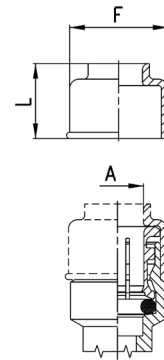

PRODUKTÜBERSICHT				
Mod.	A	F	L	Gewicht (g)
6708 4	4	10.7	10.7	1
6708 5	5	11.7	11	1
6708 6	6	13.7	11.5	1
6708 8	8	15.7	12.5	1
6708 10	10	18.5	13	1
6708 12	12	20.7	15	2
6708 14	14	23.7	15	2

Verschluss-Stecker Mod. 6900 Micro



Werkstoff: Kunststoff/Polyamid

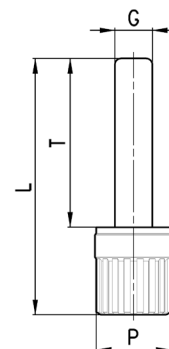

PRODUKTÜBERSICHT					
Mod.	G	L	P	T	Gewicht (g)
6900 3	3	20.5	6	13.5	1

Verschluss-Stecker Mod. 6900

Werkstoff: Kunststoff/Polyamid

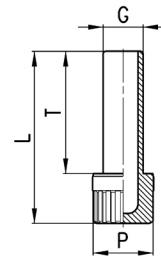

PRODUKTÜBERSICHT					
Mod.	G	L	P	T	Gewicht (g)
6900 4	4	29	8	20	1
6900 5	5	29.5	8	20.5	1
6900 6	6	31.5	8	22.5	1
6900 8	8	34.5	12	24.5	2
6900 10	10	37	12	27	2
6900 12	12	40.5	16	28.5	3
6900 14	14	42.5	16	30.5	3

Schlauchlösewerkzeug-Set Mod. SP

Für Durchmesser 4-12 mm



PRODUKTÜBERSICHT
Mod.
SP

Steckverschraubungen Superrapid aus Kunststoff Serie 7000

Durchmesser: \varnothing 4, 6, 8, 10, 12, 16 mm

Anschlüsse: M5, M7, G1/8", G1/4", G3/8", G1/2", G3/4"

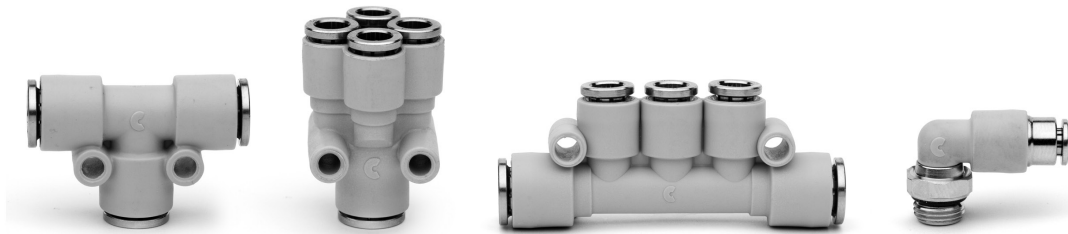

Die Modelle der Serie 7000 sind aus Thermoplast produziert, unter Beibehaltung des erprobten Halte- und Dichtungssystems der Camozzi Superrapid Verschraubungen Serie 6000.

Leichte Bauweise, flexible Einsatzmöglichkeiten sowie die Möglichkeit des Austauschs der Haltezange und des O-Rings zeichnen dieses Programm aus.

» Die Stopp-Verschraubungen haben ein integriertes Rückschlagventil, es unterbricht den Durchfluss beim Lösen des Schlauches und gibt ihn beim Stecken wieder frei.

ALLGEMEINE KENNGRÖSSEN

Durchmesser	\varnothing 4, 6, 8, 10, 12, 16 mm
Gewinde	G zylindrisch ISO 228 (BSP), M5-M7, andere auf Anfrage
Betriebstemperatur	-20° ÷ 60°C (schlauch- und druckabhängig)
Werkstoffe Schlauch	Polyamid 6 - 11 - 12, Polyethylen, Polyurethan, Thermoplastisches Polyester-Elastomer
Medium	Druckluft (andere Medien auf Anfrage)
Werkstoffe	Körper Kunststoff, Einsatz Messing, Zange Messing vernickelt, O-Ring NBR, Gewindedichtung NBR
Betriebsdruck	-0,9 bar ÷ 16 bar (schlauchabhängig)

Funktionsprinzip

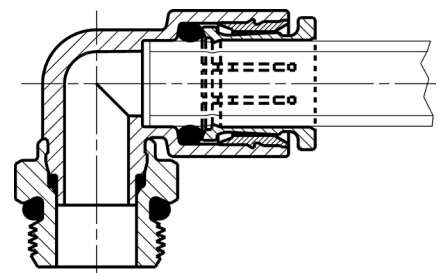

Winkel-Einschraub-Verschraubung Mod. 7522

Mit O-Ring montiert, zylindrisch, drehbar

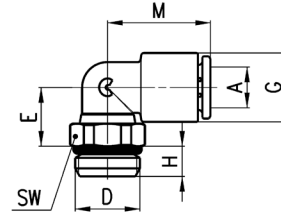

PRODUKTÜBERSICHT								
Mod.	A	D	E	G	H	M	SW	Gewicht (g)
7522 4-M5	4	M5	8.5	9.4	3.5	17	9	4
7522 4-M7	4	M7	11	9.4	5	17	10	6
7522 4-1/8	4	G1/8	9	9.4	5	17	12	7
7522 4-1/4	4	G1/4	9	9.4	6	17	14	10
7522 6-M5	6	M5	9.5	11.6	3.5	18.5	9	5
7522 6-M7	6	M7	12	11.6	5	18.5	10	7
7522 6-1/8	6	G1/8	10	11.6	5	18.5	12	8
7522 6-1/4	6	G1/4	10	11.6	6	18.5	14	11
7522 8-1/8	8	G1/8	13.5	13.9	5	20.5	12	11
7522 8-1/4	8	G1/4	12	13.9	6	20.5	14	13
7522 8-3/8	8	G3/8	12.5	13.9	7	20.5	19	21
7522 10-1/4	10	G1/4	14.5	16.1	6	24	14	15
7522 10-3/8	10	G3/8	13.5	16.1	7	24	19	21
7522 10-1/2	10	G1/2	13.5	16.1	8	24	24	30
7522 12-1/4	12	G1/4	16	20.2	6	28	17	20
7522 12-3/8	12	G3/8	15	20.2	7	28	19	25
7522 12-1/2	12	G1/2	15.5	20.2	8	28	24	34
7522 16-1/2	16	G1/2	30	27	8	33.5	24	61
7522 16-3/4	16	G3/4	24	27	9	33.5	30	70

Winkel-Einschraub-Verschraubung Mod. 7522...LF

Mit O-Ring montiert, zylindrisch, drehbar, mit integriertem Rückschlagventil

Diese Version unterbricht den Durchfluss beim Lösen des Schlauches und gibt ihn beim Stecken wieder frei.

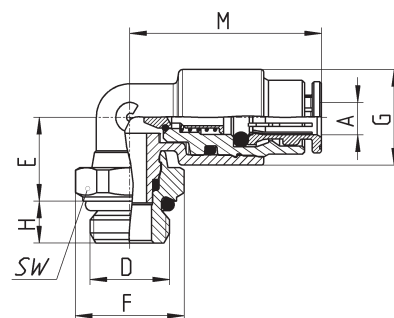
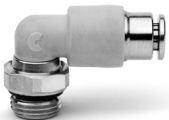

PRODUKTÜBERSICHT									
Mod.	A	D	E	F	G	H	M	SW	Gewicht (g)
7522 4-1/8-LF	4	G1/8	10	13	1.6	5	23	12	11
7522 6-1/8-LF	6	G1/8	13.5	13	13.9	5	37.5	12	23

Winkel-Einschraub-Verschraubung Mod. 7526

Mit O-Ring montiert, zylindrisch, drehbar, ermöglicht bei z. B. Ventilblöcken das parallele Verlegen von Rohren - kombiniert mit Mod. 7522

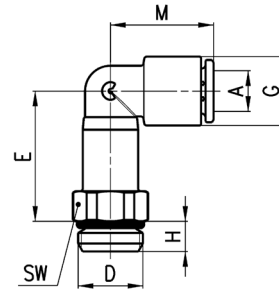

PRODUKTÜBERSICHT								
Mod.	A	D	E	G	H	M	SW	Gewicht (g)
7526 4-M7	4	M7	24	9,4	5	17	10	7
7526 4-1/8	4	G1/8	22	9,4	5	17	12	12
7526 6-M7	6	M7	25	11,6	5	18,5	10	10
7526 6-1/8	6	G1/8	23	11,6	5	18,5	12	13
7526 6-1/4	6	G1/4	23	11,6	5	18,5	14	16
7526 8-1/8	8	G1/8	29	13,9	5	20,5	12	18
7526 8-1/4	8	G1/4	27	13,9	6	20,5	14	20

L-Einschraub-Verschraubung Mod. 7442

Mit O-Ring montiert, zylindrisch, drehbar

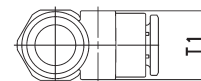
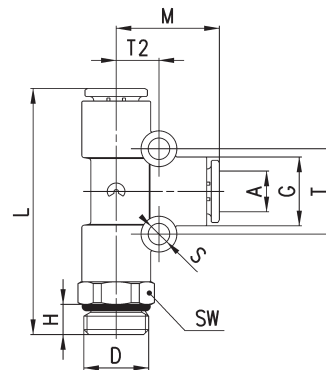

PRODUKTÜBERSICHT												
Mod.	A	D	G	H	L	M	S	T	T1	T2	SW	Gewicht (g)
7442 4-1/8	4	G1/8	9,4	5	40	16,5	4	13	9,2	6,5	12	11
7442 6-1/8	6	G1/8	11,6	5	44	18,5	4	15	11,4	7,5	12	15
7442 6-1/4	6	G1/4	11,6	6	45	18,5	4	15	11,4	7,5	14	18
7442 8-1/8	8	G1/8	13,9	5	49	20,5	4	17	13,7	8,5	14	23
7442 8-1/4	8	G1/4	13,9	6	49	20,5	4	17	13,7	8,5	17	22
7442 8-3/8	8	G3/8	13,9	7	50,5	20,5	4	17	13,7	8,5	19	29
7442 10-1/4	10	G1/4	16,1	6	57	24	4	16	15,8	8	17	32
7442 10-3/8	10	G3/8	16,1	7	57,5	24	4	16	15,8	8	19	33
7442 12-3/8	12	G3/8	20,2	7	65,5	28	4	19,2	9	9,6	19	51
7442 12-1/2	12	G1/2	20,2	8	66,5	28	4	19,2	9	9,6	24	58
7442 16-1/2	16	G1/2	27	8	71,5	33,5	-	-	-	-	24	80
7442 16-3/4	16	G3/4	27	9	66,5	33,5	-	-	-	-	30	90

* = ohne Befestigungsbohrungen

T-Einschraub-Verschraubung Mod. 7432

Mit O-Ring montiert, zylindrisch, drehbar

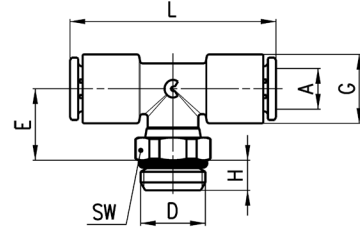

PRODUKTÜBERSICHT								
Mod.	A	D	E	G	H	L	SW	Gewicht (g)
7432 4-M5	4	M5	14	9,4	3,5	34	9	7
7432 4-1/8	4	G1/8	11,5	9,4	5	34	12	9
7432 6-M5	6	M5	15,5	11,6	3,5	37	9	9
7432 6-1/8	6	G1/8	13	11,6	5	37	12	11
7432 6-1/4	6	G1/4	13	11,6	6	37	14	13
7432 8-1/8	8	G1/8	16	13,9	5	41	12	15
7432 8-1/4	8	G1/4	14,5	13,9	6	41	14	17
7432 8-3/8	8	G3/8	15,5	13,9	7	41	19	25
7432 10-1/4	10	G1/4	18,5	16,1	6	48	14	21
7432 10-3/8	10	G3/8	17,5	16,1	7	48	19	27
7432 12-1/4	12	G1/4	31,5	20,2	6	56	20	49
7432 12-3/8	12	G3/8	30,5	20,2	7	56	20	51
7432 12-1/2	12	G1/2	30,5	20,2	8	56	24	58
7432 16-1/2	16	G1/2	30	27	8	67	24	80
7432 16-3/4	16	G3/4	24	27	9	67	30	90

STECKVERSCHRAUBUNGEN SUPERRAPID AUS KUNSTSTOFF SERIE 7000

Einschraub-Verteiler Mod. 7542

Mit O-Ring montiert, zylindrisch, drehbar

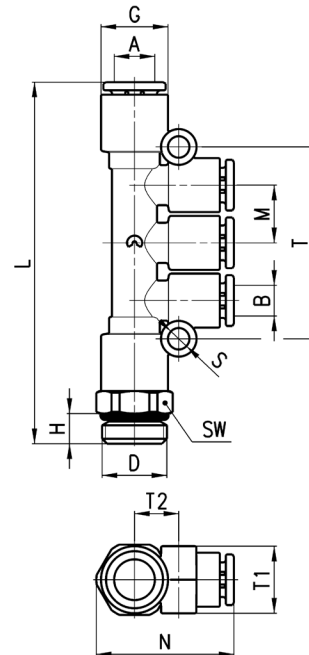

PRODUKTÜBERSICHT														
Mod.	A	B	D	G	H	L	M	N	S	SW	T	T1	T2	Gewicht (g)
7542 6-4-1/8	6	4	G1/8	11,6	5	62,5	9,6	24,5	4	12	32,5	11	7,5	18
7542 6-4-1/4	6	4	G1/4	11,6	6	63,5	9,6	25,5	4	14	32,5	11	7,5	21
7542 8-6-1/8	8	6	G1/8	13,9	5	72	11,5	27,5	4	14	38,2	13,5	9	28
7542 8-6-1/4	8	6	G1/4	13,9	6	72	11,5	27,5	4	14	38,2	13,5	9	26
7542 10-8-1/4	10	8	G1/4	16,1	6	87,5	14,1	31	4	17	45,8	16	10,5	41
7542 10-8-3/8	10	8	G3/8	16,1	7	88	14,1	32	4	19	45,8	16	10,5	42

Y-Einschraub-Verschraubung Mod. 7562

Mit O-Ring montiert, zylindrisch, drehbar

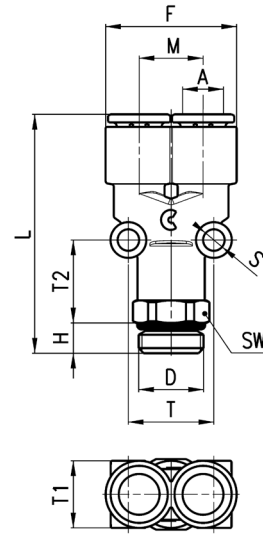

PRODUKTÜBERSICHT												
Mod.	A	D	F	H	L	M	S	SW	T	T1	T2	Gewicht (g)
7562 4-1/8	4	G1/8	18,5	5	40,5	9	4	12	12,2	11,6	16,5	13
7562 6-1/8	6	G1/8	23	5	44	11,4	4	14	14,5	14	18,5	15
7562 6-1/4	6	G1/4	23	6	44	11,4	4	14	14,5	14	17,5	29
7562 8-1/8	8	G1/8	27,2	5	47,5	13,5	4	14	17	14	17,5	24
7562 8-1/4	8	G1/4	26,2	6	49	12,7	4	17	16,5	15,5	19,5	30
7562 10-1/4	10	G1/4	31,7	6	55	15,8	4	17	16,5	16	19,5	32
7562 10-3/8	10	G3/8	31,7	7	55,5	15,8	4	19	16,5	16	19	34

4-fach Verteiler Mod. 7572

Mit O-Ring montiert, zylindrisch, drehbar

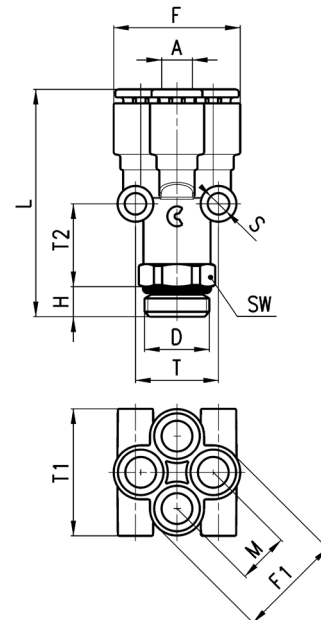

PRODUKTÜBERSICHT													
Mod.	A	D	H	F	F1	L	M	S	SW	T	T1	T2	Gewicht (g)
7572 4-1/8	4	G1/8	5	20,5	17	40,5	8,3	4	12	14,5	20,5	15	17
7572 4-1/4	4	G1/4	6	20,5	17	41,5	8,3	4	14	14,5	20,5	15	21
7572 6-1/8	6	G1/8	5	25	21	45,5	10,2	4	14	16,5	25	17,5	27
7572 6-1/4	6	G1/4	6	25	21	45,5	10,2	4	14	16,5	25	16,5	25

Winkel-Einschraub-Verschraubung Mod. 7622

Mit O-Ring montiert, zylindrisch, drehbar

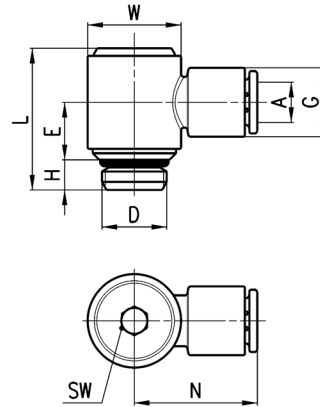

PRODUKTÜBERSICHT										
Mod.	A	D	E	G	H	L	N	W	SW	Gewicht (g)
7622 4-1/8	4	G1/8	10	11,6	5	24,5	21	14	4	12
7622 6-1/8	6	G1/8	10	11,6	5	24,5	21	14	4	12
7622 6-1/4	6	G1/4	12,5	11,6	6	28	24,5	18,5	5	25
7622 8-1/8	8	G1/8	10	13,9	5	24,5	22,5	14	4	14
7622 8-1/4	8	G1/4	12,5	13,9	6	28	24,5	18,5	5	26
7622 10-1/4	10	G1/4	12,5	16,1	6	28	27	18,5	5	27
7622 10-3/8	10	G3/8	12,5	16,1	7	29	27	18,5	5	28
7622 12-3/8	12	G3/8	14	20,2	7	33,5	29	22	5	43

Winkel-Einschraub-Verschraubung 2-fach Mod. 7652

Mit O-Ring montiert, zylindrisch, drehbar

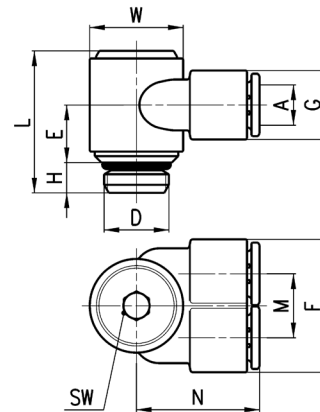

PRODUKTÜBERSICHT												
Mod.	A	D	E	F	G	H	L	M	N	W	SW	Gewicht (g)
7652 4-1/8	4	G1/8	10	22,3	11,6	5	24,5	10,7	21	14	4	15
7652 6-1/8	6	G1/8	10	22,3	11,6	5	24,5	10,7	21	14	4	15
7652 6-1/4	6	G1/4	11,5	26,6	11,6	6	28	12,7	24,5	18,5	5	29
7652 8-1/8	8	G1/8	10	26,6	13,9	5	24,5	12,7	22	14	4	18
7652 8-1/4	8	G1/4	11,5	26,6	13,9	6	28	12,7	24,5	18,5	5	30
7652 10-1/4	10	G1/4	11,5	31	16	6	28	15	26,5	18,5	5	33
7652 10-3/8	10	G3/8	11,5	31	16	7	29	15	26,5	18,5	5	34

Schwenkringstück Mod. 7610

Kombinierbar mit Hohlschrauben Mod. 7632 02, 7632 03

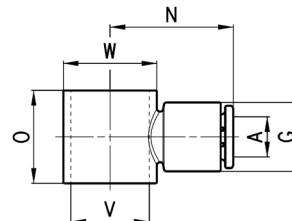

PRODUKTÜBERSICHT							
Mod.	A	G	N	O	V	W	Gewicht (g)
7610 4-1/8	4	11,6	21	15,5	11	14	3
7610 6-1/8	6	11,6	21	15,5	11	14	4
7610 6-1/4	6	13,9	24,5	18,5	15,5	18,5	6
7610 8-1/8	8	13,9	22,5	15,5	11	14	5
7610 8-1/4	8	13,9	24,5	18,5	15,5	18,5	7
7610 10-1/4	10	16,1	27	18,5	15,5	18,5	7
7610 10-3/8	10	20,2	29	22	18	22	11
7610 12-3/8	12	20,2	29	22	18	22	12

Schwenkringstück 2-fach Mod. 7640

Kombinierbar mit Hohlschrauben Mod. 7632 02, 7632 03

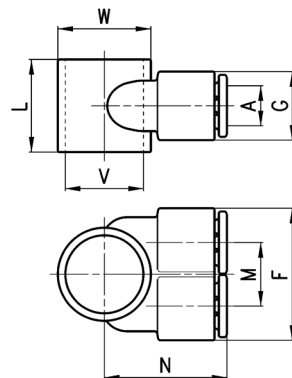

PRODUKTÜBERSICHT									
Mod.	A	F	G	L	M	N	V	W	Gewicht (g)
7640 4-1/8	4	22,3	11,6	15,5	10,7	21	11	14	6
7640 6-1/8	6	22,3	11,6	15,5	10,7	21	11	14	7
7640 6-1/4	6	26,6	13,9	18,5	12,7	24,5	15,5	18,5	9
7640 8-1/8	8	26,6	13,9	15,5	12,7	22	11	14	10
7640 8-1/4	8	26,6	13,9	18,5	12,7	24,5	15,5	18,5	10
7640 10-1/4	10	31	16	18,5	15	26,5	15,5	18,5	13

Hohlschraube 2-fach Mod. 7632



Kombinierbar mit Schwenkringstücken
Mod. 7610, 7640

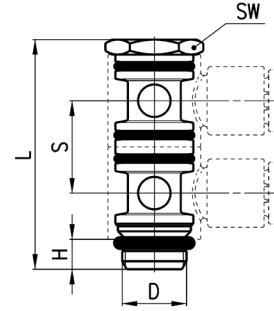

PRODUKTÜBERSICHT

Mod.	D	H	L	S	SW	Gewicht (g)
7632 02-1/8	G1/8	5	38,5	15,5	13	14
7632 02-1/4	G1/4	6	46	18,5	17	29
7632 02-3/8	G3/8	7	54	22	20	45

Hohlschraube 3-fach Mod. 7632



Kombinierbar mit Schwenkringstücken
Mod. 7610, 7640

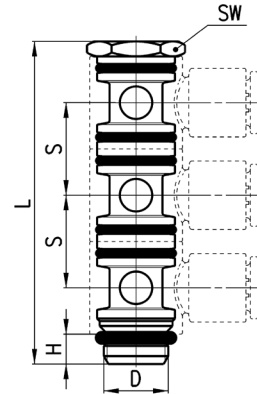

PRODUKTÜBERSICHT

Mod.	D	H	L	S	SW	Gewicht (g)
7632 03-1/8	G1/8	5	54	15,5	13	18
7632 03-1/4	G1/4	6	64,5	18,5	17	39

Hohlschraube 2-fach mit Schwenkringstück Mod. 7612 -02



Mit O-Ring montiert, zylindrisch

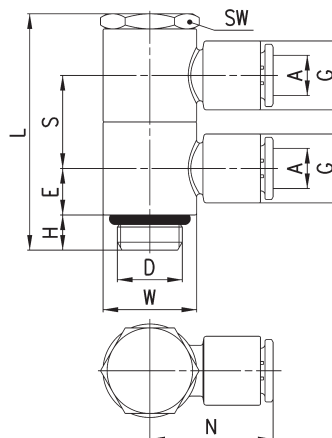

PRODUKTÜBERSICHT											
	A	D	E	G	H	L	N	S	W	SW	Gewicht (g)
7612 02-4-1/8	4	G1/8	7,75	11,6	5	38,5	21	15,5	14	13	21
7612 02-6-1/8	6	G1/8	7,75	11,6	5	38,5	21	15,5	14	13	21
7612 02-6-1/4	6	G1/4	9,25	13,9	6	46	24,5	18,5	18,5	17	40
7612 02-8-1/8	8	G1/8	7,75	13,9	5	38,5	22,5	15,5	14	13	24
7612 02-8-1/4	8	G1/4	9,25	13,9	6	46	24,5	18,5	18,5	17	42
7612 02-10-1/4	10	G1/4	9,25	16,1	6	46	27	18,5	18,5	17	44
7612 02-10-3/8	10	G3/8	11	20,2	7	54	29	22	22	20	67
7612 02-12-3/8	12	G3/8	11	20,2	7	54	29	22	22	20	69

Hohlschraube 3-fach mit Schwenkringstück Mod. 7612 -03



Mit O-Ring montiert, zylindrisch

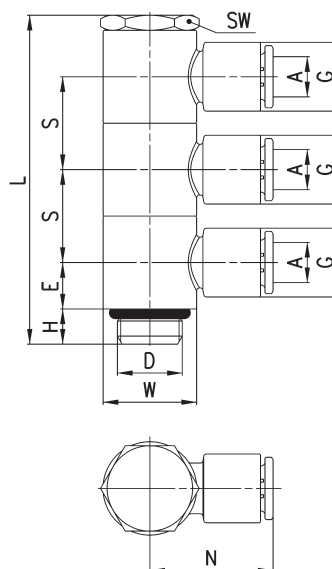

PRODUKTÜBERSICHT											
	A	D	E	G	H	L	N	S	W	SW	Gewicht (g)
7612 03-4-1/8	4	G1/8	7,75	11,6	5	54	21	15,5	14	13	29
7612 03-6-1/8	6	G1/8	7,75	11,6	5	54	21	15,5	14	13	30
7612 03-6-1/4	6	G1/4	9,25	13,9	6	64,5	24,5	18,5	18,5	17	55
7612 03-8-1/8	8	G1/8	7,75	13,9	5	54	22,5	15,5	14	13	34
7612 03-8-1/4	8	G1/4	9,25	13,9	6	64,5	24,5	18,5	18,5	17	57
7612 03-10-1/4	10	G1/4	9,25	16,1	6	64,5	27	18,5	18,5	17	62

Hohlschraube 2-fach mit Schwenkringstück 2-fach Mod. 7642 -02

Mit O-Ring montiert, zylindrisch

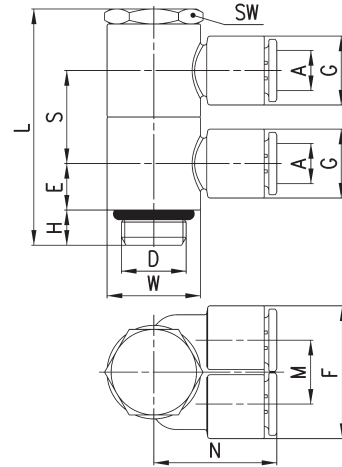

PRODUKTÜBERSICHT													
Mod.	A	D	E	F	G	H	L	M	N	S	W	SW	Gewicht (g)
7642 02-4-1/8	4	G1/8	7,75	22,3	11,6	5	38,5	10,7	21	15,5	14	13	26
7642 02-6-1/8	6	G1/8	7,75	22,3	11,6	5	38,5	10,7	21	15,5	14	13	28
7642 02-6-1/4	6	G1/4	9,25	26,6	13,9	6	46	12,7	24,5	18,5	18,5	17	48
7642 02-8-1/8	8	G1/8	7,75	26,6	13,9	5	38,5	12,7	22	15,5	14	13	33
7642 02-8-1/4	8	G1/4	9,25	26,6	13,9	6	46	12,7	24,5	18,5	18,5	17	50
7642 02-10-1/4	10	G1/4	9,25	31	16	6	46	15	26,5	18,5	18,5	17	56

Hohlschraube 3-fach mit Schwenkringstück 2-fach Mod. 7642 -03

Mit O-Ring montiert, zylindrisch

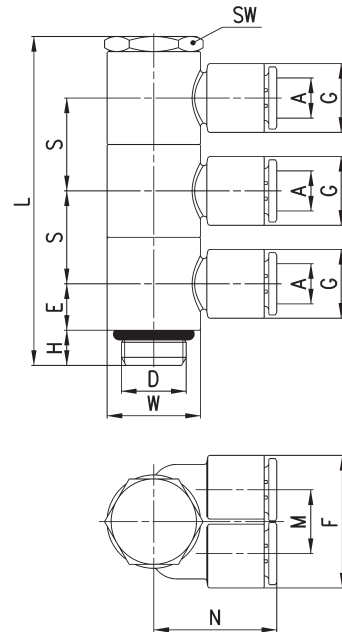

PRODUKTÜBERSICHT													
Mod.	A	D	E	F	G	H	L	M	N	S	W	SW	Gewicht (g)
7642 03-4-1/8	4	G1/8	7,75	22,3	11,6	5	54	10,7	21	15,5	14	13	37
7642 03-6-1/8	6	G1/8	7,75	22,3	11,6	5	54	10,7	21	15,5	14	13	39
7642 03-6-1/4	6	G1/4	9,25	26,6	13,9	6	64,5	12,7	24,5	18,5	18,5	17	67
7642 03-8-1/8	8	G1/8	7,75	26,6	13,9	5	54	12,7	22,5	15,5	14	13	47
7642 03-8-1/4	8	G1/4	9,25	26,6	13,9	6	64,5	12,7	24,5	18,5	18,5	17	71
7642 03-10-1/4	10	G1/4	9,25	31	16,1	6	64,5	15	27	18,5	18,5	17	79

Reduzierung Mod. 7800

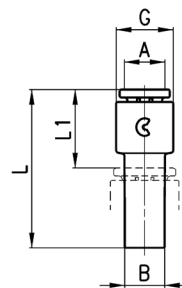

PRODUKTÜBERSICHT						
Mod.	A	B	G	L1	L	Gewicht (g)
7800 4-6	4	6	9,4	14,5	29,5	2
7800 4-8	4	8	9,4	14,5	30,5	3
7800 6-8	6	8	11,6	15,5	31,5	4
7800 6-10	6	10	11,6	15,5	34	4
7800 6-12	6	12	11,6	16,5	35,5	4
7800 8-10	8	10	13,9	16,5	35	5
7800 8-12	8	12	13,9	17,5	37	6
7800 10-12	10	12	16,1	18,5	37,5	7
7800 10-14	10	14	16,1	22,5	39	7

Winkelsteckanschluss Mod. 7555

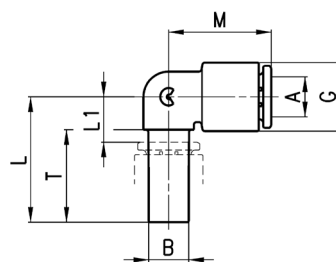

PRODUKTÜBERSICHT								
Mod.	A	B	G	L	L1	M	T	Gewicht (g)
7555 4-4	4	4	9,4	21	7	16,5	16,5	2
7555 6-6	6	6	11,6	23	8	18,5	17,5	4
7555 8-8	8	8	13,9	25	9	20,5	18,5	5
7555 10-10	10	10	16,1	28,5	10	24	21	8
7555 12-12	12	12	20,2	32	13	28	23	12

Gerader Verbinder Mod. 7580

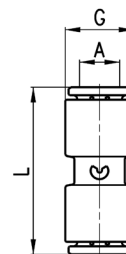

PRODUKTÜBERSICHT				
Mod.	A	G	L	Gewicht (g)
7580 4	4	9,4	29	4
7580 6	6	11,6	31	6
7580 8	8	13,9	33,5	9
7580 10	10	16,1	38,5	11
7580 12	12	20,2	39,5	18

Winkel-Anschluss Mod. 7550

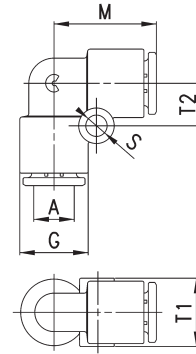

PRODUKTÜBERSICHT							
Mod.	A	G	M	S	T1	T2	Gewicht (g)
7550 4	4	9,4	16,5	4	9,2	6,5	4
7550 6	6	11,6	18,5	4	11,4	7,5	6
7550 8	8	13,9	20,5	4	13,7	8,5	9
7550 10	10	16,1	24	4	15,8	8	12
7550 12	12	20,2	28	4	9	9,6	20
7550 16	16	27	33,5	-	-	-	42

* ohne Befestigungsbohrung

T-Anschluss Mod. 7540

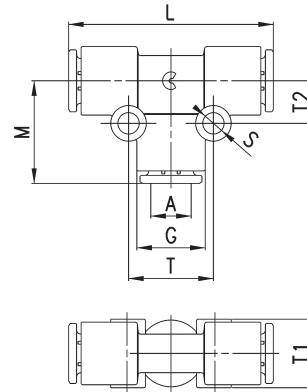

PRODUKTÜBERSICHT									
Mod.	A	G	L	M	S	T	T1	T2	Gewicht (g)
7540 4	4	9,2	33	16,5	4	13	9,2	6,5	6
7540 6	6	11,6	37	18,5	4	15	11,4	7,5	9
7540 8	8	13,9	41	20,5	4	17	13,7	8,5	14
7540 10	10	16,1	48	24	4	16	15,8	8	18
7540 12	12	20,2	56	28	4	19,2	9	9,6	30
7540 16	16	27	67	33,5	-	-	-	-	61

* = ohne Befestigungsbohrung

Verteiler-Anschluss Mod. 7545

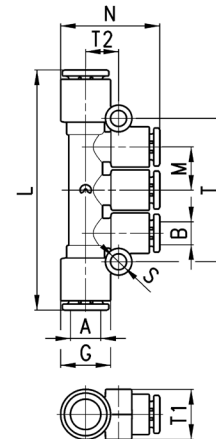

PRODUKTÜBERSICHT											
Mod.	A	B	G	L	M	N	S	T	T1	T2	Gewicht (g)
7545 6-4	6	4	11,6	55,5	9,6	23,5	4	32,5	11	7,5	12
7545 8-6	8	6	13,9	64	11,5	26,5	4	38,2	13,5	9	18
7545 10-8	10	8	16,1	78,5	14,1	30	4	45,8	16	10,5	27

Y-Anschluss Mod. 7560

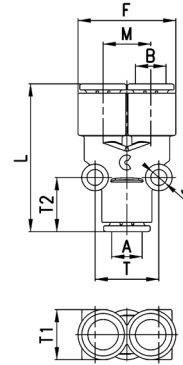

PRODUKTÜBERSICHT										
Mod.	A	B	F	L	M	S	T	T1	T2	Gewicht (g)
7560 4	4	4	18,2	33	9	4	10,8	9,5	13	6
7560 6	6	6	23	35	11,4	4	14,5	11,5	13,5	9
7560 8	8	8	27,2	39,5	13,5	4	17	14	14,5	15
7560 10	10	10	31,7	46	15,8	4	16,5	16	16,5	19
7560 6-4	6	4	18,5	33,5	9	4	12,2	11,6	14,5	7
7560 8-6	8	6	23	36	11,4	4	14,5	14	15,5	11
7560 10-8	10	8	26,2	40	12,7	4	16,5	15,5	16	16

4-fach Verteiler mit Steckanschluss Mod. 7575

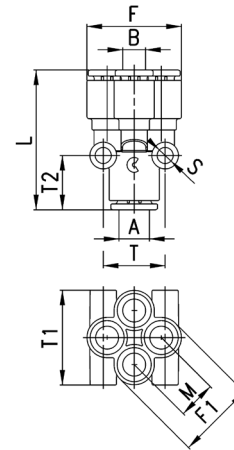

PRODUKTÜBERSICHT											
Mod.	A	B	F	F1	L	M	S	T	T1	T2	Gewicht (g)
7575 6-4	6	4	20,5	17	33,5	8,3	4	14,5	20,5	13,5	12
7575 8-6	8	6	25	21	37	10,2	4	16,5	25	14,5	17

Verbindungs-Stecker Mod. 7950

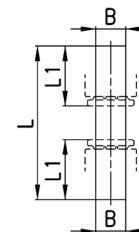

PRODUKTÜBERSICHT				
Mod.	B	L	L1	Gewicht (g)
7950 4	4	37	14	1
7950 6	6	39	15	1
7950 8	8	41	16	1
7950 10	10	44	18,5	1
7950 12	12	49	19	1

Steckverschraubungen Superrapid aus Kunststoff Serie 7000 Fluidics

Durchmesser: Ø 6, 8, 10, 12, 16 mm
Anschlüsse: M5, G1/8", G1/4", G3/8", G1/2", G3/4"

STECKVERSCHRAUBUNGEN SUPERRAPID AUS KUNSTSTOFF SERIE 7000 FLUIDICS



Die Steckverschraubungen der Serie 7000 Fluidics ermöglichen einen optimalen Durchfluss von Flüssigkeiten in Kühlsystemen. Flüssigkeitskühlsysteme sind effizienter und meist geräuschärmer als Luftkühlsysteme. Sie eignen sich daher für zahlreiche Anwendungen, von Servern bis hin zu Industrieanlagen. Die Serie wurde mit einem speziellen Kunststoff entwickelt, der auf ökologischen Rohstoffen basiert. Das Material ermöglicht eine Beständigkeit gegen Wasseraufnahme, Temperaturschwankungen und Kühlmittelzusätze. Es behält im Kontakt mit verschiedenen Flüssigkeiten eine konstante Formstabilität und überzeugt durch Langlebigkeit.

Die hervorragenden Halteeigenschaften machen die Serie 7000 Fluidics zu einer hervorragenden Alternative zu herkömmlichen Verschraubungen, da sie einen sicheren Halt des Schlauches garantieren. Dies erhöht die Zuverlässigkeit und Beständigkeit bei wiederholtem Montieren und Lösen des Schlauchs. Eine zuverlässige Verbindung, kompakte Abmessungen und eine einfache Installation in beengten Bauräumen sind nur einige der Merkmale, die diese Verschraubungen zu einer innovativen Lösung für eine breite Palette von Kühlsystemen machen.

- » VORTEILE:
- » Einfaches Verbinden und Lösen
- » Resistent gegen Wasserdruck und Erosion
- » Resistent gegen Korrosion
- » Formstabilität im Kontakt mit Wasser
- » Lange Lebensdauer

ALLGEMEINE KENNGRÖSSEN

Durchmesser	Ø6mm	Ø8mm	Ø10mm	Ø12mm	Ø16mm
Betriebsdruck bei -20°/+40°	16bar	16bar	14bar	14bar	12bar
Betriebsdruck bei -20°/+70°	16bar	14bar	12bar	10bar	8bar
Betriebsdruck bei -20°/+100°	14bar	12bar	10bar	8bar	6bar
Gewinde	G zylindrisch ISO-228 (BSP), M5				
Werkstoffe Schlauch	Polyurethan (PU), Polyethylen (PE), Polyamid (PA), Fluoropolymer (PTFE)				
Medium	Geeignet für die industrielle Wasserversorgung und spezielle Kühlflüssigkeiten. (Zur Verwendung mit anderen Medien kontaktieren Sie bitte unsere technische Abteilung.)				
Werkstoffe	Körper: PA11, Dichtungen: EPDM, Gewinde: chemisch vernickelt, Spannzange (ohne Medienkontakt): vernickelt				

Funktionsprinzip

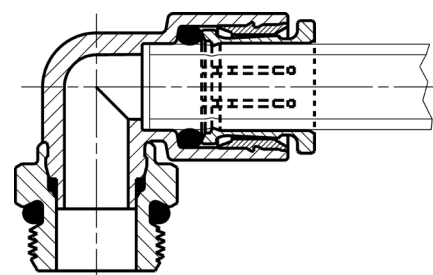

Gerade Einschraub-Verschraubungen Mod. F6512K

Mit O-Ring montiert, zylindrisch

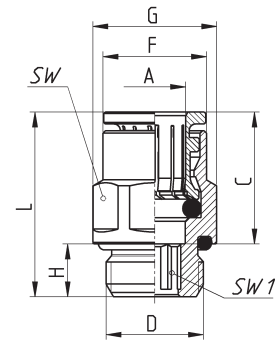

PRODUKTÜBERSICHT										
Mod.	A	D	C	F	G	H	L	SW	SW1	Gewicht (g)
F6512 6-1/8K	6	G1/8	16.0	11.7	13.5	6	21	12	4	10
F6512 6-1/4K	6	G1/4	16.0	11.7	16.4	7	22	15	4	13
F6512 8-1/8K	8	G1/8	17.5	13.7	15.2	6	26	14	5	15
F6512 8-1/4K	8	G1/4	17.5	13.7	16.4	7	24.5	15	6	17
F6512 8-3/8K	8	G3/8	17.5	13.7	20.5	7	23	19	6	27
F6512 10-1/4K	10	G1/4	20.2	15.4	18.5	7	30	17	7	26
F6512 10-3/8K	10	G3/8	20.2	15.4	20.5	7	24.5	19	8	27
F6512 10-1/2K	10	G1/2	20.2	15.4	24.8	8	25	22	8	39
F6512 12-3/8K	12	G3/8	19.2	18.3	20.5	7	24	19	9	24
F6512 12-1/2K	12	G1/2	19.2	18.3	24.8	8	24.5	22	9	37
F6512 16-1/2K*	16	G1/2	23.0	23.5	26.5	8	33.5	24	-	49
F6512 16-3/4K*	16	G3/4	23.0	23.5	30	9	29.5	24	-	58

Gerade Aufschraub-Verschraubung Mod. F6463K

Zylindrisch

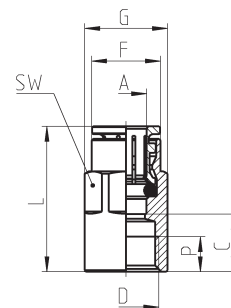

PRODUKTÜBERSICHT										
Mod.	A	D	C	F	G	L	P (min)	SW	Gewicht (g)	
F6463 6-1/8K	6	G1/8	10	11.7	13	26	6	12	14	
F6463 6-1/4K	6	G1/4	11.5	11.9	16.5	27.5	7	15	23	
F6463 8-1/8K	8	G1/8	9.5	13.7	15.2	27	6	14	16	
F6463 8-1/4K	8	G1/4	11.5	13.7	16.5	29	7	15	23	
F6463 8-3/8K	8	G3/8	13	13.7	20	30.5	8	15	29	
F6463 10-1/4K	10	G1/4	11.3	15.4	18.5	31.5	7	17	29	
F6463 10-3/8K	10	G3/8	12.8	15.4	20	33	8	17	34	
F6463 10-1/2K	10	G1/2	16.8	15.4	24	37	9.5	17	44.5	
F6463 12-3/8K	12	G3/8	12.8	18.3	20.5	32	8	19	40	
F6463 12-1/2K	12	G1/2	16.8	18.3	24	36	9.5	19	50.5	
F6463 16-1/2K*	16	G1/2	16.5	23.5	26.5	40	9.5	24	63	
F6463 16-3/4K*	16	G3/4	18.5	23.5	30	42	11	24	77	

Einpress-Patrone Mod. F6700K



S* = Bohrungsgeometrie Metall/
Kunststoff
siehe Einbaugeometrie rechts

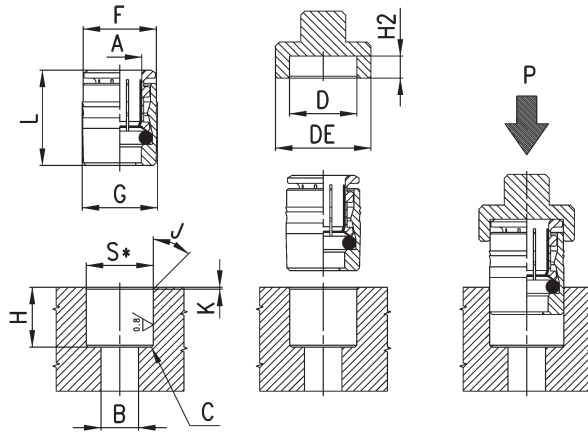

PRODUKTÜBERSICHT																
Mod.	A	B	C	D	DE	F	G	H	H2 (+0,1/0)	J	K	L	P min (Kg)	P max (Kg)	S (+0,01/-0,04)	Gewicht (g)
F6700 6K	6	4	0.5x45°	12	17	11.8	12.2	12	3.8	15°	0.5	16.5	160	570	11.95	8
F6700 8K	8	6	0.5x45°	14	19	13.8	14.2	14	3.3	15°	0.5	18	140	400	13.95	11
F6700 10K	10	8	0.5x45°	16	21	15.8	16.2	16.5	3.5	15°	0.5	20.5	150	650	15.95	15

Winkel-Einschraub-Verschraubung Mod. F7522K

Mit O-Ring montiert, zylindrisch, drehbar

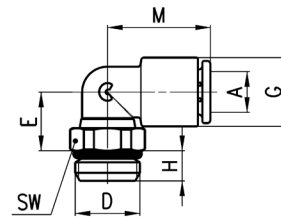

PRODUKTÜBERSICHT								
Mod.	A	D	E	G	H	M	SW	Gewicht (g)
F7522 6-M5K	6	M5	9.3	11.4	3.5	18.5	9	7
F7522 6-1/8K	6	G1/8	10	11.6	5	18.5	12	8
F7522 6-1/4K	6	G1/4	10	11.6	6	18.5	14	11
F7522 8-1/8K	8	G1/8	13.5	13.9	5	20.5	12	11
F7522 8-1/4K	8	G1/4	12	13.9	6	20.5	14	13
F7522 8-3/8K	8	G3/8	12.5	13.9	7	20.5	19	21
F7522 10-1/4K	10	G1/4	14.5	16.1	6	24	14	15
F7522 10-3/8K	10	G3/8	13.5	16.1	7	24	19	21
F7522 10-1/2K	10	G1/2	13.5	16.1	8	24	24	30
F7522 12-1/4K	12	G1/4	16	20.2	6	28	17	20
F7522 12-3/8K	12	G3/8	15	20.2	7	28	19	25
F7522 12-1/2K	12	G1/2	15.5	20.2	8	28	24	34
F7522 16-1/2K*	16	G1/2	30	27	8	33.5	24	61
F7522 16-3/4K*	16	G3/4	24	27	9	33.5	30	70

Winkel-Einschraub-Verschraubung Mod. F7526K

Mit O-Ring montiert, zylindrisch, drehbar

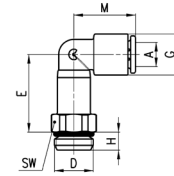

PRODUKTÜBERSICHT								
Mod.	A	D	E	G	H	M	SW	Gewicht (g)
F7526 6-1/8K	6	G1/8	23	11,6	5	18,5	12	13
F7526 6-1/4K	6	G1/4	23	11,6	5	18,5	14	16
F7526 8-1/8K	8	G1/8	29	13,9	5	20,5	12	18
F7526 8-1/4K	8	G1/4	27	13,9	6	20,5	14	20
F7526 8-3/8K	8	G3/8	27,7	13,9	7	20,5	19	30
F7526 10-1/4K	10	G1/4	32,2	15,8	6	24	14	28,5
F7526 10-3/8K	10	G3/8	32,2	15,8	7	24	19	35
F7526 10-1/2K	10	G1/2	32,2	15,8	8	24	24	45
F7526 12-3/8K	12	G3/8	36,2	20	7	28	19	41,5
F7526 12-1/2K	12	G1/2	36,2	20	8	28	24	49,5
F7526 16-1/2K*	16	G1/2	58,9	27	8	34	24	106,5
F7526 16-3/4K*	16	G3/4	58,9	27	9	34	30	116

Winkel-Anschluss Mod. F7550

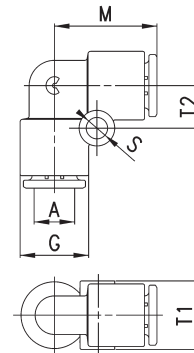

PRODUKTÜBERSICHT							
Mod.	A	G	M	S	T1	T2	Gewicht (g)
F7550 6	6	11,6	18,5	4	11,4	7,5	6
F7550 8	8	13,9	20,5	4	13,7	8,5	9
F7550 10	10	16,1	24	4	15,8	8	12
F7550 12	12	20,2	28	4	9	9,6	20
F7550 16*	16	27	33,5	-	-	-	42

F7550 16 = ohne Befestigungsbohrung

Gerader Verbinder Mod. F7580

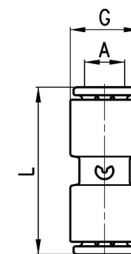

PRODUKTÜBERSICHT				
Mod.	A	G	L	Gewicht (g)
F7580 6	6	11,6	31	6
F7580 8	8	13,9	33,5	9
F7580 10	10	16,1	38,5	11
F7580 12	12	20,2	39,5	18

T-Anschluss Mod. F7540

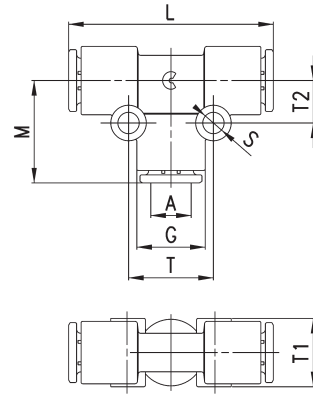

PRODUKTÜBERSICHT									
Mod.	A	G	L	M	S	T	T1	T2	Gewicht (g)
F7540 6	6	11,6	37	18,5	4	15	11,4	7,5	9
F7540 8	8	13,9	41	20,5	4	17	13,7	8,5	14
F7540 10	10	16,1	48	24	4	16	15,8	8	18
F7540 12	12	20,2	56	28	4	19,2	9	9,6	30
F7540 16*	16	27	67	33,5	-	-	-	-	61

F7540 16 = ohne Befestigungsbohrung

Y-Anschluss Mod. F7560

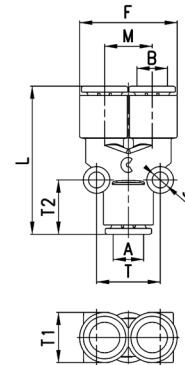

PRODUKTÜBERSICHT										
Mod.	A	B	F	L	M	S	T	T1	T2	Gewicht (g)
F7560 6	6	6	23	35	11,4	4	14,5	11,5	13,5	9
F7560 8	8	8	27,2	39,5	13,5	4	17	14	14,5	15
F7560 10	10	10	31,7	46	15,8	4	16,5	16	16,5	19

Verteiler-Anschluss Mod. F7545

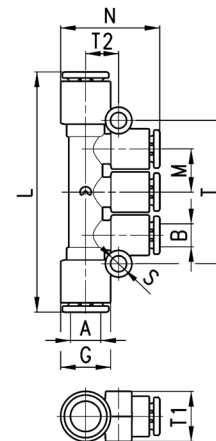

PRODUKTÜBERSICHT											
Mod.	A	B	G	L	M	N	S	T	T1	T2	Gewicht (g)
F7545 8-6	8	6	13,9	64	11,5	26,5	4	38,2	13,5	9	18
F7545 10-8	10	8	16,1	78,5	14,1	30	4	45,8	16	10,5	27

Winkelsteckanschluss Mod. F7555

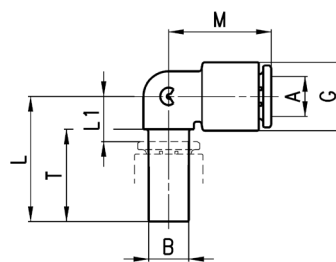

PRODUKTÜBERSICHT								
Mod.	A	B	G	L	L1	M	T	Gewicht (g)
F7555 6-6	6	6	11,6	23	8	18,5	17,5	4
F7555 8-8	8	8	13,9	25	9	20,5	18,5	5
F7555 10-10	10	10	16,1	28,5	10	24	21	8
F7555 12-12	12	12	20,2	32	13	28	23	12

Reduzierung Mod. F7800

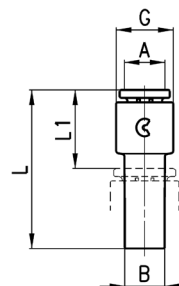

PRODUKTÜBERSICHT						
Mod.	A	B	G	L1	L	Gewicht (g)
F7800 4-6	4	6	9,4	14,5	29,5	2
F7800 4-8	4	8	9,4	14,5	30,5	3
F7800 6-8	6	8	11,6	15,5	31,5	4
F7800 6-10	6	10	11,6	15,5	34	4
F7800 6-12	6	12	11,6	16,5	35,5	4
F7800 8-10	8	10	13,9	16,5	35	5
F7800 8-12	8	12	13,9	17,5	37	6
F7800 10-12	10	12	16,1	18,5	37,5	7

Verschluss-Stück Mod. F6750K

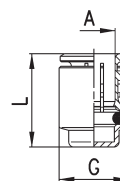

PRODUKTÜBERSICHT				
Mod.	A	G	L	Gewicht (g)
F6750 6K	6	11.8	17	7
F6750 8K	8	13.8	18.5	9
F6750 10K	10	15.8	21	12
F6750 12K	12	17.8	20	15
F6750 16K*	16	23.5	24.5	26

Verschluss-Stecker Mod. 6900

Werkstoff: Kunststoff/Polyamid

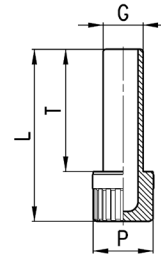

PRODUKTÜBERSICHT					
Mod.	G	L	P	T	Gewicht (g)
6900 6	6	31.5	8	22.5	1
6900 8	8	34.5	12	24.5	2
6900 10	10	37	12	27	2
6900 12	12	40.5	16	28.5	3

Verschluss-Schraube Mod. 2611

Zylindrisch

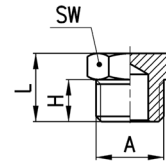

PRODUKTÜBERSICHT					
Mod.	A	H	L	SW	Gewicht (g)
2611 1/8	G1/8	6	10,5	13	7
2611 1/4	G1/4	8	13	17	13
2611 3/8	G3/8	9	14	19	18
2611 1/2	G1/2	10	15,5	24	31
2611 1	G1	13	19	38	76

Kreuz-Verteiler Mod. 3033

Werkstoff: Aluminium eloxiert

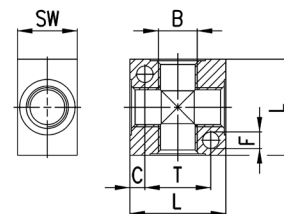
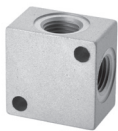

PRODUKTÜBERSICHT							
Mod.	B	C	F	L	T	SW	Gewicht (g)
3033 1/8	G1/8	4	4,5	25	17	16	18
3033 1/4	G1/4	5	5,5	32	22	20	35
3033 3/8	G3/8	7	5,5	40	26	25	73
3033 1/2	G1/2	8	5,5	50	34	30	137

Verteilerblock, Abgänge beidseitig, Mod. 3043

Werkstoff: Aluminium eloxiert

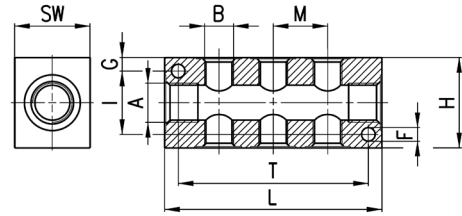

PRODUKTÜBERSICHT												
Mod.	A	ABGÄNGE BEIDSEITIG	B	F	G	H	I	L	M	T	SW	Gewicht (g)
3043 1/4-3D-1/8	G1/4	3	G1/8	4.5	4.5	30	21	72	18	63	20	85
3043 1/4-4D-1/8	G1/4	4	G1/8	4.5	4.5	30	21	90	18	81	20	107
3043 1/4-5D-1/8	G1/4	5	G1/8	4.5	4.5	30	21	108	18	99	20	128
3043 1/4-6D-1/8	G1/4	6	G1/8	4.5	4.5	30	21	126	18	117	20	151
3043 3/8-3D-1/4	G3/8	3	G1/4	5.5	6	40	28	92	24	75	25	177
3043 3/8-4D-1/4	G3/8	4	G1/4	5.5	6	40	28	116	24	99	25	224
3043 3/8-5D-1/4	G3/8	5	G1/4	5.5	6	40	28	140	24	123	25	270
3043 3/8-6D-1/4	G3/8	6	G1/4	5.5	6	40	28	164	24	147	25	315
3043 1/2-3D-3/8	G1/2	3	G3/8	5.5	6.5	50	37	104	26	85	30	287
3043 1/2-4D-3/8	G1/2	4	G3/8	5.5	6.5	50	37	130	26	111	30	356
3043 1/2-5D-3/8	G1/2	5	G3/8	5.5	6.5	50	37	156	26	137	30	427
3043 1/2-6D-3/8	G1/2	6	G3/8	5.5	6.5	50	37	182	26	163	30	495

Verteilerblock, Abgänge seitlich, Mod. 3053

Werkstoff: Aluminium eloxiert

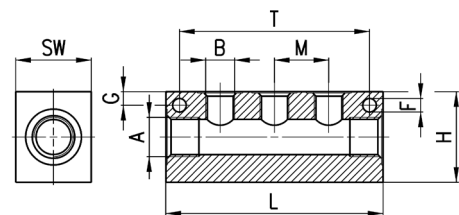

PRODUKTÜBERSICHT											
Mod.	A	Anzahl Abgänge	B	F	G	H	L	M	T	SW	Gewicht (g)
3053 1/4-3L-1/8	G1/4	3	G1/8	4.5	4.5	30	72	18	63	20	92
3053 1/4-4L-1/8	G1/4	4	G1/8	4.5	4.5	30	90	18	81	20	116
3053 1/4-5L-1/8	G1/4	5	G1/8	4.5	4.5	30	108	18	99	20	140
3053 1/4-6L-1/8	G1/4	6	G1/8	4.5	4.5	30	126	18	117	20	164
3053 3/8-3L-1/4	G3/8	3	G1/4	5.5	6	40	92	24	75	25	191
3053 3/8-4L-1/4	G3/8	4	G1/4	5.5	6	40	116	24	99	25	243
3053 3/8-5L-1/4	G3/8	5	G1/4	5.5	6	40	140	24	123	25	294
3053 3/8-6L-1/4	G3/8	6	G1/4	5.5	6	40	164	24	147	25	345
3053 1/2-3L-3/8	G1/2	3	G3/8	5.5	6.5	50	104	26	85	30	313
3053 1/2-4L-3/8	G1/2	4	G3/8	5.5	6.5	50	130	26	111	30	395
3053 1/2-5L-3/8	G1/2	5	G3/8	5.5	6.5	50	156	26	137	30	474
3053 1/2-6L-3/8	G1/2	6	G3/8	5.5	6.5	50	182	26	163	30	551

Steckverschraubungen Dual Seal Superrapid Serie 8000

Durchmesser: \varnothing 4, 6, 8, 10, 12 mm
Anschlüsse: G1/8", G1/4", G3/8", G1/2"

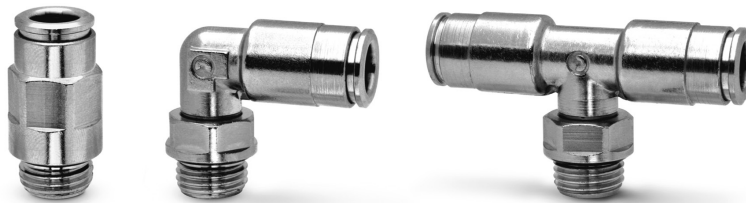

Diese Serie zeichnet sich durch ein doppeltes Dichtsystem aus. Sie beruht auf der bewährten Serie 6000. Das Hauptmerkmal der Serie 8000 ist die Integration von zusätzlichen Dichtungen (patentiert). Das doppelte Dichtsystem gewährt eine äußerst zuverlässige Verbindung bei gleichzeitig sicherem Halt des Schlauchs, auch bei mehrmaligem Stecken und Lösen.

Die Verschraubungen Dual Seal Superrapid sind in 6 verschiedenen Ausführungen erhältlich. Steckanschlüsse sowie Einschraub-Verschraubungen bilden das Sortiment der Serie 8000. Die Montage und Demontage des Schlauchs oder Rohrs ist ohne Werkzeug möglich und führt zu bedeutender Zeitersparnis während der Installation oder Instandhaltungen. Die NBR-Dichtungen können sehr einfach ersetzt werden. Auf Anfrage ebenfalls in FKM oder EDPM erhältlich.

ALLGEMEINE KENNGRÖSSEN

Durchmesser	\varnothing 4, 6, 8, 10, 12 mm
Gewinde	G zylindrisch ISO 228 (BSP), andere auf Anfrage
Betriebstemperatur	-20°C ÷ 80°C (schlauch-/rohr- und druckabhängig)
Werkstoffe Schlauch/Rohr	Polyamid 6 - 11 - 12, Polyethylen, Polyurethan, Thermoplastisches Polyester-Elastomer, PTFE und entgratete metallische Rohre
Medium	Alle Medien, die hohe Dichtigkeit erfordern, insbesondere Flüssigkeiten wie Wasser etc. Andere Medien nach Rücksprache mit unseren Technikern.
Werkstoffe	Körper + Zange Messing vernickelt, O-Ring + Gewindedichtung NBR
Betriebsdruck	-0,9 ÷ 60 bar. Die Serie 8000 hat einen max. Druckbereich von 60 bar (schlauch-/rohrabhängig).

Funktionsprinzip

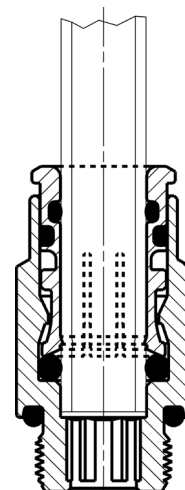

Gerade Einschraub-Verschraubung Mod. 8512

Mit O-Ring montiert, zylindrisch

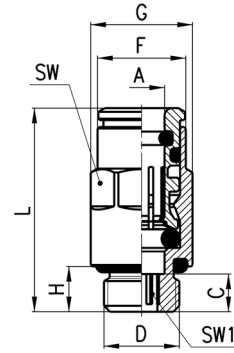

PRODUKTÜBERSICHT										
Mod.	A	D	C	F	G	H	L	SW	SW1	Gewicht (g)
8512 4-1/8	4	G1/8	5	8.8	13.5	6	23.8	12	2.5	14
8512 6-1/8	6	G1/8	5	11.7	13.5	6	27	12	4	15
8512 6-1/4	6	G1/4	6	11.7	16.4	7	28	15	4	25
8512 8-1/8	8	G1/8	8.5	13.7	15.2	6	32.5	14	5	20
8512 8-1/4	8	G1/4	7	13.7	16.4	7	31	15	6	24
8512 10-1/4	10	G1/4	10	16.3	18.5	7	36.5	17	7	32
8512 10-3/8	10	G3/8	4.5	16.3	20.5	7	31	19	8	38
8512 12-3/8	12	G3/8	4.6	18.4	20.5	7	30.5	19	9	30
8512 12-1/2	12	G1/2	5.6	18.4	24.8	8	31.5	22	9	50

Winkel-Einschraub-Verschraubung Mod. 8522

Mit O-Ring montiert, zylindrisch, drehbar

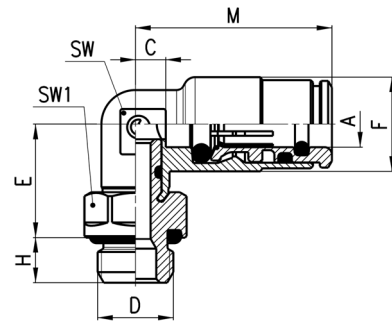

PRODUKTÜBERSICHT										
Mod.	A	D	C	E	F	H	M	SW	SW1	Gewicht (g)
8522 4-1/8	4	G1/8	3	14.5	10	6	21.5	9	12	18
8522 6-1/8	6	G1/8	4	15	12.5	6	26	10	12	23
8522 6-1/4	6	G1/4	4	16	12.5	7	26	10	15	30
8522 8-1/8	8	G1/8	5	16	14.5	6	29	12	12	28
8522 8-1/4	8	G1/4	5	17	14.5	7	29	12	15	34
8522 10-1/4	10	G1/4	5	19.5	16.8	7	31.5	13	15	40
8522 10-3/8	10	G3/8	5	19.5	16.8	7	31.5	13	19	50
8522 12-3/8	12	G3/8	7	20.5	19	7	33	15	19	55
8522 12-1/2	12	G1/2	7	21.5	19	8	33	15	22	68

T-Einschraub-Verschraubung Mod. 8432

Mit O-Ring montiert, zylindrisch, drehbar

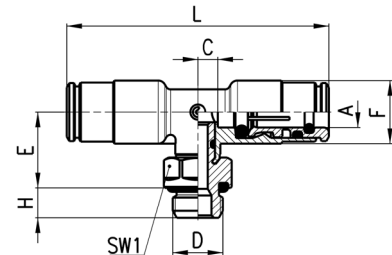

PRODUKTÜBERSICHT										
Mod.	A	D	C	E	F	H	L	SW1	Gewicht (g)	
8432 4-1/8	4	G1/8	3	14,5	10	6	43	12	25	
8432 6-1/8	6	G1/8	4	15	12,5	6	52	12	33	
8432 8-1/8	8	G1/8	5	16	14,5	6	58	12	42	
8432 8-1/4	8	G1/4	5	17	14,5	7	58	15	49	

Gerader Verbinder Mod. 8580

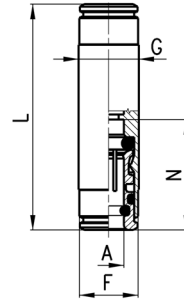

PRODUKTÜBERSICHT						
Mod.	A	F	G	L	N	Gewicht (g)
8580 4	4	8,8	10	38	19	16
8580 6	6	11,7	12	45	22	23
8580 8	8	-	14	48	24	30

T-Anschluss Mod. 8540

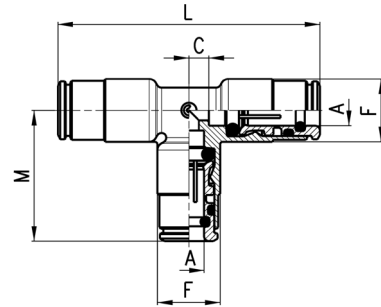

PRODUKTÜBERSICHT						
Mod.	A	C	F	M	L	Gewicht (g)
8540 4	4	3	10	21,5	43	22
8540 6	6	4	12,5	26	52	35
8540 8	8	5	14,5	29	58	49

Winkel-Anschluss Mod. 8550

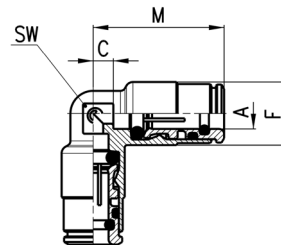

PRODUKTÜBERSICHT						
Mod.	A	C	F	M	SW	Gewicht (g)
8550 4	4	3	10	21,5	9	15
8550 6	6	4	12,5	26	10	25
8550 8	8	5	14,5	29	12	34

Steckverschraubungen Dual Seal Superrapid Serie H8000

Durchmesser: \varnothing 4, 6, 8, 10, 12 mm
Anschlüsse: G1/8", G1/4", G3/8", G1/2"



Die Steckverschraubungen der Serie H8000 sind im Bereich der Spannzange so ausgeführt, dass Schmutz, Staub und andere Verunreinigungen nicht in den Innenraum der Verschraubung dringen können.

Das doppelte Dichtsystem gewährt eine äußerst zuverlässige Verbindung mit geringsten Leckagen, bei gleichzeitig sicherem Halt des Schlauchs/Rohrs auch bei mehrmaligem Stecken und Lösen.

Die Verschraubungen Serie H8000 haben einen Körper aus Messing, Dichtungen in FKM für hohe Temperaturen (verfügbar auch in EPDM und NBR) und können bei Betriebsdruck -0,9 ÷ 60 bar eingesetzt werden.

- » Schutz gegen Staub und Verunreinigungen
- » Frei von Silikon
- » Für Vakuumeinsatz geeignet
- » Geeignet auch für metallische Rohre

ALLGEMEINE KENNGRÖSSEN

Durchmesser	\varnothing 4, 6, 8, 10, 12 mm
Gewinde	G zylindrisch ISO 228 (BSP), andere auf Anfrage
Betriebstemperatur	Dichtungen in FKM (Standard): -15°C ÷ 200°C (bei trockener Luft) Dichtungen in EPDM (auf Anfrage): -40°C ÷ 110°C Dichtungen in NBR (auf Anfrage): -20°C ÷ 80°C
Werkstoffe Schlauch/Rohr	Polyamid 6 - 11 - 12, Polyethylen, Polyurethan, Thermoplastisches Polyester-Elastomer, PTFE und entgratete metallische Rohre
Medium	Alle Medien, die hohe Dichtigkeit erfordern, insbesondere Flüssigkeiten wie Wasser etc. Andere Medien nach Rücksprache mit unseren Technikern.
Werkstoffe	Körper + Zange Messing vernickelt O-Ring + Gewindedichtung FKM (EPDM und NBR auf Anfrage)
Betriebsdruck	-0.9 ÷ 60 bar Die Serie H8000 hat einen maximalen Druckbereich von 60 bar (schlauch-/rohrabhängig).

Funktionsprinzip

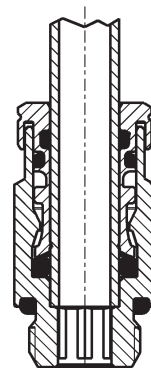

Gerade Einschraub-Verschraubung Mod. H8512

Mit O-Ring montiert, zylindrisch

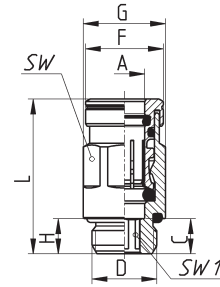

PRODUKTÜBERSICHT										
Mod.	A	D	C	F	G	H	L	SW	SW1	Gewicht (g)
H8512 4-1/8-V	4	G1/8	5	10.5	13.5	6	23.5	12	2.5	17
H8512 6-1/8-V	6	G1/8	5	13.5	13.5	6	27	12	4	18
H8512 6-1/4-V	6	G1/4	6	13.5	16.4	7	28	15	4	27.5
H8512 8-1/8-V	8	G1/8	8.5	15.5	16.4	6	32	15	6	23
H8512 8-1/4-V	8	G1/4	7	15.5	16.4	7	31	15	6	27
H8512 8-3/8-V	8	G3/8	5	15.5	20.5	7	29	15	6	42
H8512 10-1/8-V	10	G1/8	8.5	18	18.5	7	35	17	5	33.5
H8512 10-1/4-V	10	G1/4	10	18	18.5	7	36.5	17	7	35.5
H8512 10-3/8-V	10	G3/8	4.5	18	20.5	7	31	19	8	42
H8512 10-1/2-V	10	G1/2	4.5	18	24.8	8	31	22	8	63
H8512 12-1/4-V	12	G1/4	10.1	20	20.5	7	37	19	7	38.5
H8512 12-3/8-V	12	G3/8	4.6	20	20.5	7	32	19	9	35
H8512 12-1/2-V	12	G1/2	5.6	20	24.8	8	33	22	9	56

Winkel-Einschraub-Verschraubung Mod. H8522

Mit O-Ring montiert, zylindrisch, drehbar

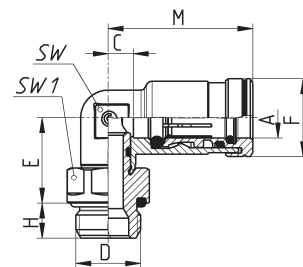

PRODUKTÜBERSICHT										
Mod.	A	D	C	E	F	H	M	SW	SW1	Gewicht (g)
H8522 4-1/8-V	4	G1/8	3	14.5	10.5	6	22	9	12	19.5
H8522 6-1/8-V	6	G1/8	4	15	13.5	6	26	10	12	25
H8522 6-1/4-V	6	G1/4	4	16	13.5	7	26	10	15	31.5
H8522 8-1/8-V	8	G1/8	5	16	15.5	6	29	12	12	30
H8522 8-1/4-V	8	G1/4	5	17	15.5	7	29	12	15	37.5
H8522 8-3/8-V	8	G3/8	5	17	15.5	7	29	12	19	47
H8522 10-1/8-V	10	G1/8	6	19.5	18	7	32.5	13	14	40
H8522 10-1/4-V	10	G1/4	5	19.5	18	7	32.5	13	15	44
H8522 10-3/8-V	10	G3/8	5	19.5	18	7	32.5	13	19	55
H8522 10-1/2-V	10	G1/2	6	19.5	18	8	32.5	13	22	66
H8522 12-1/4-V	12	G1/4	7	20.5	20	7	34	15	17	55
H8522 12-3/8-V	12	G3/8	7	20.5	20	7	34	15	19	60
H8522 12-1/2-V	12	G1/2	7	21.5	20	8	34	15	22	71

Gerader Verbinder Mod. H8580

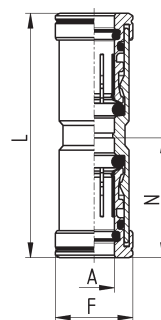

PRODUKTÜBERSICHT					
Mod.	A	F	N	L	Gewicht (g)
H8580 4-V	4	10.5	19	38	18.5
H8580 6-V	6	13.5	22	45	26.5
H8580 8-V	8	15.5	24	49	35
H8580 10-V	10	18	26.5	54	49.5
H8580 12-V	12	20	27	55	58

T-Anschluss Mod. H8540

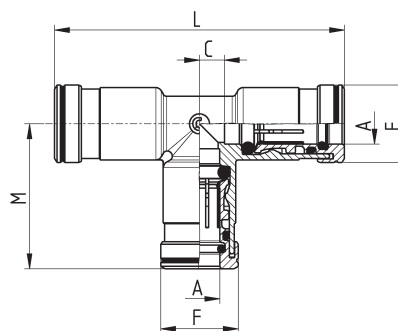

PRODUKTÜBERSICHT						
Mod.	A	C	F	M	L	Gewicht (g)
H8540 4-V	4	3	10.5	22	44	28
H8540 6-V	6	4	13.5	26	52	43
H8540 8-V	8	5	15.5	29	58	55
H8540 10-V	10	6	18	32.5	64	78
H8540 12-V	12	7	20	34	67	90

Winkel-Anschluss Mod. H8550

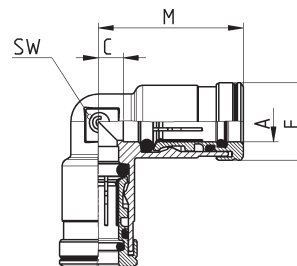

PRODUKTÜBERSICHT						
Mod.	A	C	F	M	SW	Gewicht (g)
H8550 4-V	4	3	10.5	22	9	20
H8550 6-V	6	4	13.5	26	10	30
H8550 8-V	8	5	15.5	29	12	40
H8550 10-V	10	6	18	32.5	-	54
H8550 12-V	12	7	20	34	-	64

Steckverschraubungen Superrapid aus Edelstahl 1.4404 Serie X6000

Durchmesser: \varnothing 4, 6, 8, 10, 12 mm

Anschlüsse: G1/8", G1/4", G3/8", G1/2", R1/8", R1/4", R3/8", R1/2"



STECKVERSCHRAUBUNGEN SUPERRAPID AUS EDELSTAHL SERIE X6000



Die Verschraubungen X6000 aus Edelstahl 1.4404 erlauben Verbindungen für Flüssigkeiten auch in aggressiven Umgebungen. Diese Serie eignet sich für Anwendungen in der Pneumatik, Fluidtechnik, Chemie, Medizin, der Lebensmittel- und Verpackungsindustrie.

Die Serie zeichnet sich durch Vielseitigkeit, Qualität, Zuverlässigkeit und eine einfache Montage aus. Die Spannzange sorgt für eine sichere Verbindung zwischen Verschraubung und Schlauch.

ALLGEMEINE KENNGRÖSSEN

Durchmesser	\varnothing 4, 6, 8, 10, 12 mm	
Gewinde	R konisch ISO 7 (BSPT) G zylindrisch ISO 228 (BSP)	andere auf Anfrage
Betriebstemperatur	-15°C ÷ 150°C (schlauch- und druckabhängig)	
Werkstoffe Schlauch	Polyamid 6 - 11 - 10.12 - 12, Polyethylen, Polyurethan, PTFE	
Medium	Druckluft und Trinkwasser (andere Medien auf Anfrage)	
Werkstoffe	1 = Körper 2 = Dichtungen 3 = Führungsring 4 = Haltezange 5 = Stützring 6 = Lösering	Edelstahl 1.4404 FKM Lebensmittel geeignet Edelstahl 1.4404 Edelstahl 1.4310 Edelstahl 1.4404 Edelstahl 1.4404
Betriebsdruck	Max. 18 bar (schlauchabhängig)	Bitte technische Daten der verwendeten Schläuche beachten.

Funktionsprinzip

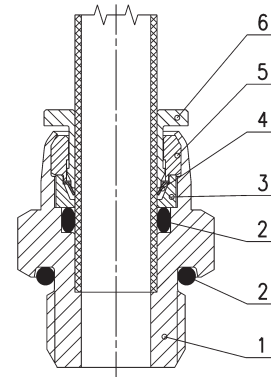

Gerade Einschraub-Verschraubung Mod. X6510

Konisch

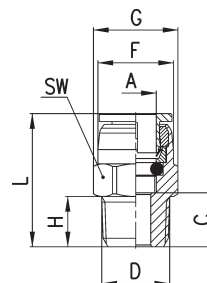

PRODUKTÜBERSICHT										
Mod.	A	C	D	F	G	H	L	SW	Gewicht (g)	VE
X6510 4-1/8	4	8	R1/8	9.7	-	8	20.5	10	9	10
X6510 4-1/4	4	10	R1/4	9.7	-	10	22.5	14	15	10
X6510 6-1/8	6	8	R1/8	11.6	13.4	8	21.5	12	10	10
X6510 6-1/4	6	10	R1/4	11.6	15.2	10	23.5	14	17	10
X6510 8-1/8	8	8.5	R1/8	14.7	17	8	24.6	15	16	10
X6510 8-1/4	8	10	R1/4	14.7	17	10	26.1	15	20	10
X6510 10-1/4	10	11	R1/4	17.4	20.8	10	28.2	19	28	10
X6510 10-3/8	10	12	R3/8	17.4	20.8	11	29.2	19	35	10
X6510 10-1/2	10	14	R1/2	17.4	24.6	13	31.2	22	55	10
X6510 12-1/4	12	12	R1/4	20	-	10	31	22	42	10
X6510 12-3/8	12	12.5	R3/8	20	-	11	31.5	22	44	10
X6510 12-1/2	12	14.5	R1/2	20	-	13	33.5	22	59	10

Gerade Einschraub-Verschraubung Mod. X6512

Mit O-Ring montiert, zylindrisch

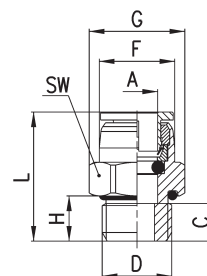

PRODUKTÜBERSICHT										
Mod.	A	C	D	F	G	H	L	SW	Gewicht (g)	VE
X6512 4-1/8	4	5.7	G1/8	9.7	-	5.7	18.2	14	11	10
X6512 4-1/4	4	6.4	G1/4	9.7	-	6	18.9	17	18	10
X6512 6-1/8	6	6.7	G1/8	11.6	15	5.7	20.2	14	12	10
X6512 6-1/4	6	6.5	G1/4	11.6	-	6	20	17	19	10
X6512 8-1/8	8	8.7	G1/8	14.7	-	5.7	24.8	15	18	10
X6512 8-1/4	8	6	G1/4	14.7	-	6	22.1	17	21	10
X6512 10-1/4	10	8.5	G1/4	17.4	-	6	25.7	19	28	10
X6512 10-3/8	10	6.5	G3/8	17.4	-	6.5	23.7	22	29	10
X6512 10-1/2	10	11.5	G1/2	17.4	30	9.5	28.7	27	60	10
X6512 12-1/4	12	8.5	G1/4	20	-	6	27.5	22	40	10
X6512 12-3/8	12	9	G3/8	20	-	6.5	28	22	42	10
X6512 12-1/2	12	12.5	G1/2	20	30	9.5	31.5	27	71	10

Winkel-Einschraub-Verschraubung Mod. X6500

Konisch

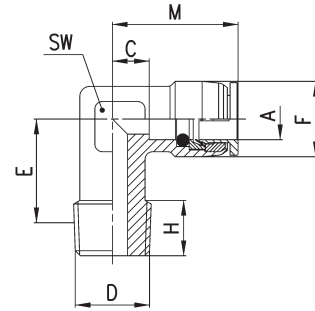

PRODUKTÜBERSICHT										
Mod.	A	C	D	E	F	H	M	SW	Gewicht (g)	VE
X6500 4-1/8	4	7.8	R1/8	12.5	11	8	20.3	12	22	10
X6500 6-1/8	6	8.8	R1/8	12.5	11.9	8	22.3	12	20	10
X6500 6-1/4	6	8.8	R1/4	12	11.9	9	22.3	12	24	10
X6500 8-1/8	8	8.4	R1/8	15	15	8	24.5	12	26	10
X6500 8-1/4	8	8.4	R1/4	14	15	10	24.5	12	25	10
X6500 10-1/4	10	8.7	R1/4	15	17.4	10	25.9	14	36	10
X6500 10-3/8	10	8.7	R3/8	15	17.4	10.8	25.9	14	41	10
X6500 12-1/4	12	9.5	R1/4	16	20	10	28.5	17	49	10
X6500 12-3/8	12	9.5	R3/8	16	20	12	28.5	17	55	10

Winkel-Einschraub-Verschraubung Mod. X6520

Konisch, drehbar

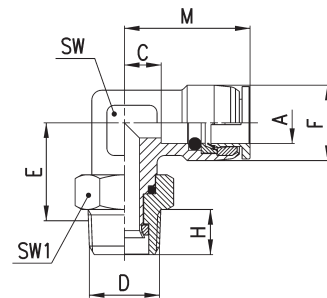

PRODUKTÜBERSICHT											
Mod.	A	C	D	E	F	H	M	SW	SW1	Gewicht (g)	VE
X6520 4-1/8	4	4.3	R1/8	15.3	10	8	16.8	12	12	20	10
X6520 4-1/4	4	4.3	R1/4	15.8	10	10	16.8	12	15	24	10
X6520 6-1/8	6	8.8	R1/8	15.3	11.9	8	22.3	12	12	24	10
X6520 6-1/4	6	5.8	R1/4	19.8	13	10	19.3	14	15	33	10
X6520 8-1/8	8	9.4	R1/8	19.5	15	8	25.5	14	12	41	10
X6520 8-1/4	8	9.4	R1/4	19.8	15	10	25.5	14	15	44	10
X6520 10-1/4	10	10.7	R1/4	20.6	17.4	10	27.9	17	15	57	10
X6520 10-3/8	10	10.7	R3/8	20.9	17.4	11	27.9	17	19	65	10
X6520 12-1/4	12	9.5	R1/4	21.1	20	10	28.5	17	15	55	10
X6520 12-3/8	12	9.5	R3/8	20.9	20	11	28.5	17	19	65	10
X6520 12-1/2	12	9.5	R1/2	19.4	20	13	28.5	17	22	80	10

T-Einschraub-Verschraubung Mod. X6430

Konisch, drehbar

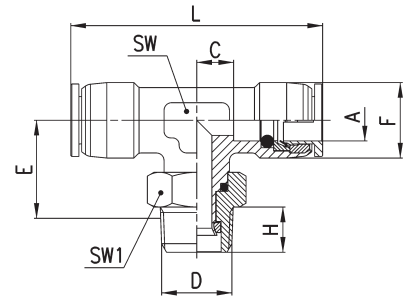

PRODUKTÜBERSICHT											
Mod.	A	C	D	E	F	H	L	SW	SW1	Gewicht (g)	VE
X6430 4-1/8	4	4.3	R1/8	15.3	10	8	33.6	12	12	33	10
X6430 4-1/4	4	4.3	R1/4	15.8	10	10	33.6	12	15	41	10
X6430 6-1/8	6	8.8	R1/8	16.1	11.9	8	44.6	12	12	33	10
X6430 6-1/4	6	5.8	R1/4	18.6	13	10	38.6	14	15	45	10
X6430 8-1/8	8	8.3	R1/8	17.3	15	8	48.8	14	12	46	10
X6430 8-1/4	8	8.3	R1/4	18.5	15	10	48.8	14	15	54	10
X6430 10-1/4	10	10.7	R1/4	21.1	17.4	10	55.8	17	15	77	10
X6430 10-3/8	10	10.7	R3/8	20.9	17.4	11	55.8	17	19	84	10
X6430 12-1/4	12	9.5	R1/4	21.1	20	10	57	17	15	79	10
X6430 12-3/8	12	9.5	R3/8	20.9	20	11	57	17	19	87	10
X6430 12-1/2	12	15.6	R1/2	19.4	20	13	57	17	22	100	10

Winkel-Einschraub-Verschraubung Mod. X6522

Mit O-Ring montiert, zylindrisch, drehbar

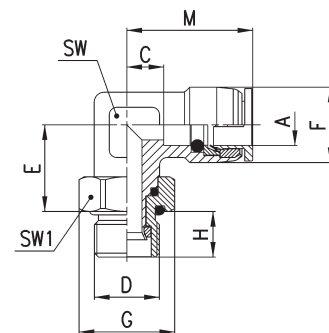

PRODUKTÜBERSICHT												
Mod.	A	C	D	E	F	G	H	M	SW	SW1	Gewicht (g)	VE
X6522 4-1/8	4	4.3	G1/8	15.3	10	15	6.5	16.8	12	14	22	10
X6522 4-1/4	4	4.3	G1/4	15.7	10	18.5	9	16.8	12	17	25	10
X6522 6-1/8	6	8.8	G1/8	15.3	11.9	15	6.5	22.3	12	14	26	10
X6522 6-1/4	6	5.8	G1/4	18.7	13	18.5	9	19.3	14	17	40	10
X6522 8-1/8	8	9.4	G1/8	19.5	15	15	6.5	25.5	14	14	43	10
X6522 8-1/4	8	9.4	G1/4	18.7	15	18.5	9	25.5	14	17	46	10
X6522 10-1/4	10	10.7	G1/4	19.5	17.4	18.5	9	27.9	17	17	59	10
X6522 10-3/8	10	10.7	G3/8	20.4	17.4	24	9	27.9	17	22	72	10
X6522 12-1/4	12	9.5	G1/4	20	20	18.5	9	28.5	17	17	63	10
X6522 12-3/8	12	9.5	G3/8	20.4	20	24	9	28.5	17	22	73	10
X6522 12-1/2	12	9.5	G1/2	20.4	20	30	9.5	28.5	17	27	83	10

T-Einschraub-Verschraubung Mod. X6432

Mit O-Ring montiert, zylindrisch, drehbar

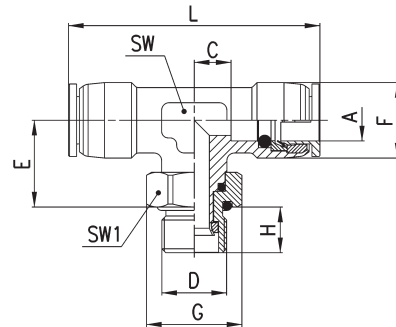

PRODUKTÜBERSICHT												
Mod.	A	C	D	E	F	G	H	L	SW	SW1	Gewicht (g)	VE
X6432 4-1/8	4	4.3	G1/8	15.3	10	15	6.5	33.6	12	14	33	10
X6432 4-1/4	4	4.3	G1/4	15.7	10	18.5	9	33.6	12	17	46	10
X6432 6-1/8	6	8.8	G1/8	16.1	11.9	15	6.5	44.6	12	14	35	10
X6432 6-1/4	6	5.8	G1/4	17.5	13	18.5	9	38.6	14	17	47	10
X6432 8-1/8	8	8.3	G1/8	17.3	15	15	6.5	48.8	14	14	52	10
X6432 8-1/4	8	8.3	G1/4	17.4	15	18.5	9	48.8	14	17	57	10
X6432 10-1/4	10	10.7	G1/4	20	17.4	18.5	9	55.8	17	17	79	10
X6432 10-3/8	10	10.7	G3/8	20.4	17.4	24	9	55.8	17	22	91	10
X6432 12-1/4	12	9.5	G1/4	20	20	18.5	9	57	17	17	82	10
X6432 12-3/8	12	9.5	G3/8	20.4	20	24	9	57	17	22	94	10
X6432 12-1/2	12	9.5	G1/2	20.4	20	30	9.5	57	17	27	115	10

Gerader Verbinder Mod. X6580

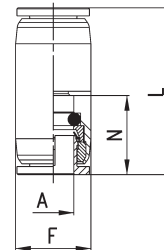
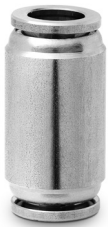

PRODUKTÜBERSICHT						
Mod.	A	F	L	N	Gewicht (g)	VE
X6580 4	4	10	26.5	12.5	10	10
X6580 6	6	12	28.4	13.5	15	10
X6580 8	8	15	33.7	16.1	26	10
X6580 10	10	18	36.4	17.2	39	10
X6580 12	12	20	41	19	54	10

Winkel-Anschluss Mod. X6550

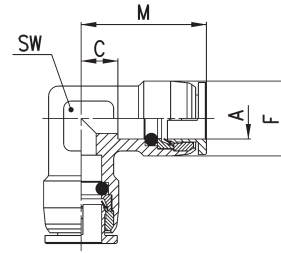

PRODUKTÜBERSICHT							
Mod.	A	C	F	M	SW	Gewicht (g)	VE
X6550 4	4	7.8	11	20.3	12	22	10
X6550 6	6	8.8	11.9	22.3	12	23	10
X6550 8	8	8.4	15	24.5	12	28	10
X6550 10	10	8.7	17.4	25.9	14	42	10
X6550 12	12	9.5	20	28.5	17	58	10

T-Anschluss Mod. X6540

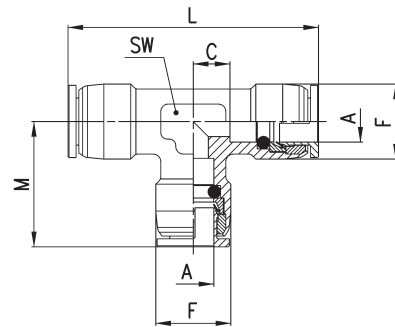

PRODUKTÜBERSICHT								
Mod.	A	C	F	L	M	SW	Gewicht (g)	VE
X6540 4	4	8.8	11	42.6	21.3	12	32	10
X6540 6	6	8.8	11.9	44.6	22.3	12	33	10
X6540 8	8	8.4	15	49	24.5	12	44	10
X6540 10	10	8.7	17.4	51.8	25.9	14	54	10
X6540 12	12	9.5	20	57	28.5	17	80	10

Gerade Schottverschraubung Mod. X6590

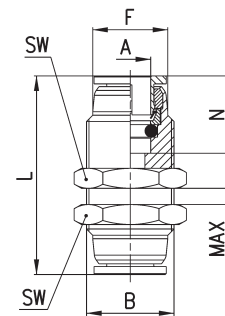

PRODUKTÜBERSICHT									
Mod.	A	B	F	L	N	MAX	SW	Gewicht (g)	VE
X6590 4	4	M11X1	9.7	29	12.5	6	14	17	10
X6590 6	6	M13X1	11.6	34	13.5	9	17	29	10
X6590 8	8	M16X1	14.7	37.2	16.1	9	19	40	10
X6590 10	10	M19X1	17.4	43.4	17.2	11	22	62	10
X6590 12	12	M22X1	20	50	19	15	27	103	10

Reduzierung Mod. X6800

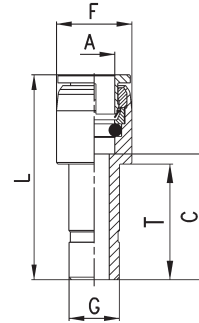

STECKVERSCHRAUBUNGEN SUPERRAPID AUS EDELSTAHL SERIE X6000

PRODUKTÜBERSICHT								
Mod.	A	C	F	G	L	T	Gewicht (g)	VE
X6800 4-6	4	16.8	10	6	29.3	15.3	7	10
X6800 4-8	4	19.8	10	8	32.3	17.8	10	10
X6800 6-8	6	19.8	12	8	33.5	17.8	11	10
X6800 6-10	6	22.6	12	10	36	21.6	12	10
X6800 6-12	6	23	12	12	36.5	-	19	10
X6800 8-10	8	22.5	15	10	38.6	20	14	10
X6800 8-12	8	24.5	15	12	40.6	23	21	10
X6800 10-12	10	26	18	12	43.2	23	27	10

Schnellverschraubungen Rapid Serie 1000

Durchmesser: \varnothing 5/3, 6/4, 8/6, 10/8, 12/10, 15/12,5 mm
 Anschlüsse: M5, M6, M12 x1, M12 x1,25, G1/8", G1/4", G3/8", G1/2"
 R1/8", R1/4", R3/8", R1/2"



Die Schnellverschraubungen der Serie 1000 können sehr einfach montiert werden. Die Rändelung der Überwurfmutter ermöglicht es, den Schlauch vorzumontieren. Die Endmontage kann über den außenliegenden Sechskant erfolgen. Die spezielle Formgebung des Stehnippels verhindert ein eventuelles Abscheren und gewährleistet den optimalen Halt des Schlauchs.

ALLGEMEINE KENNGRÖSSEN

Durchmesser D/d	Von 5/3 ÷ 15/12.5 mm
Gewinde	R konisch ISO 7, G zylindrisch ISO 228 (BSP), M5, M6, andere auf Anfrage
Betriebstemperatur	-20°C ÷ 80°C (schlauch- und druckabhängig) Hinweis: Bitte technische Daten der verwendeten Schläuche beachten.
Werkstoffe Schlauch	Polyamid, Polyethylen, Polyurethan, PVD-gewebeummantelt, Thermoplastisches Polyester-Elastomer
Medium	Druckluft und Niederdruckbereich für Flüssigkeiten und Gase
Werkstoffe	Körper + Überwurfmutter Messing vernickelt, O-Ring NBR, Gewindedichtungen PTFE - PA - AL
Betriebsdruck	Der Betriebsdruck der Verschraubung ist immer höher als der Arbeitsdruck des Schlauches.

Funktionsprinzip

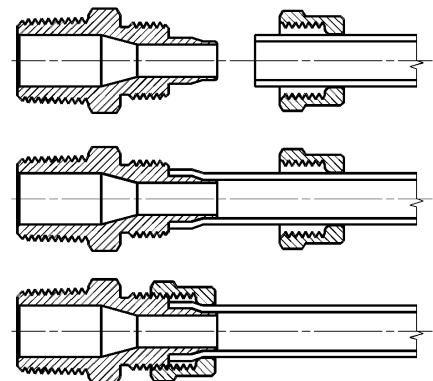

Gerade Einschraub-Verschraubung Mod. 1510



Konisch

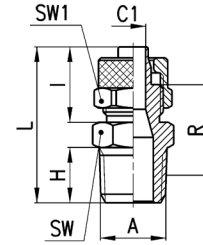

PRODUKTÜBERSICHT										
Mod.	Schlauch	A	C1	H	I	L	R	SW	SW1	Gewicht (g)
1510 5/3-1/8	5/3	R1/8	2	7,5	12,5	24,5	14,5	12	8	10
1510 6/4-1/8	6/4	R1/8	3	7,5	15	27	16	12	12	15
1510 6/4-1/4	6/4	R1/4	3	11	15	31	18,5	14	12	19
1510 6/4-3/8	6/4	R3/8	3	11,5	15	31,5	18,5	17	12	22
1510 6/4-1/2	6/4	R1/2	3	14	15	34,5	20	22	12	38
1510 6/4-M12x1,25	6/4	M12X1,25	3	10	15	30	18	13	12	17
1510 8/6-1/8	8/6	R1/8	5	7,5	15	27	16	13	14	19
1510 8/6-1/4	8/6	R1/4	5	11	15	31	18,5	14	14	20
1510 8/6-3/8	8/6	R3/8	5	11,5	15	31,5	18,5	17	14	25
1510 8/6-1/2	8/6	R1/2	5	14	15	34,5	20	22	14	39
1510 10/8-1/8	10/8	R1/8	6,5	7,5	16,5	28,5	16,5	14	16	24
1510 10/8-1/4	10/8	R1/4	6,5	11	16,5	32,5	19	14	16	24
1510 10/8-3/8	10/8	R3/8	6,5	11,5	16,5	33	19	17	16	27
1510 10/8-1/2	10/8	R1/2	6,5	14	16,5	36	20,5	22	16	42
1510 12/10-3/8	12/10	R3/8	8,5	11,5	18	34,5	19	17	19	35
1510 12/10-1/2	12/10	R1/2	8,5	14	18	37,5	20,5	22	19	49
1510 15/12,5-1/2	15/12,5	R1/2	11	14	20	39,5	21	22	22	55

Gerade Einschraub-Verschraubung Mod. 1511



Sprint®, zylindrisch

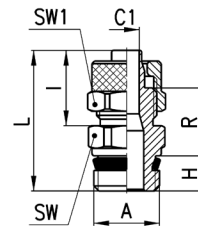

PRODUKTÜBERSICHT										
Mod.	Schlauch	A	C1	H	I	L	R	SW	SW1	Gewicht (g)
1511 5/3-M5	5/3	M5	2	4	12,5	21	10,5	8	8	5 *
1511 5/3-M6	5/3	M6	2	4	12,5	21	10,5	9	8	5 *
1511 5/3-1/8	5/3	G1/8	2	5,5	12,5	23,8	11,8	12	8	10
1511 6/4-M5	6/4	M5	3	4	13,5	22	10,5	8	9	6 *
1511 6/4-M6	6/4	M6	3	4	13,5	22	10,5	9	9	7 *
1511 6/4-1/8	6/4	G1/8	3	5,5	15	26,3	13,3	12	12	15
1511 6/4-1/4	6/4	G1/4	3	7	15	28	13,5	14	12	16
1511 6/4-3/8	6/4	G3/8	3	8	15	29,3	13,8	19	12	27
1511 8/6-1/8	8/6	G1/8	5	5,5	15	26,3	13,3	12	14	17
1511 8/6-1/4	8/6	G1/4	5	7	15	28	13,5	14	14	18
1511 8/6-3/8	8/6	G3/8	5	8	15	29,3	13,8	19	14	27
1511 10/8-1/8	10/8	G1/8	6,5	5,5	16,5	27,8	13,8	14	16	23
1511 10/8-1/4	10/8	G1/4	6,5	7	16,5	29,5	14	14	16	25
1511 10/8-3/8	10/8	G3/8	6,5	8	16,5	30,8	14,3	19	16	30
1511 10/8-1/2	10/8	G1/2	6,5	9	16,5	32,5	15	22	16	36
1511 12/10-3/8	12/10	G3/8	8,5	8	18	32,3	14,3	19	19	39
1511 12/10-1/2	12/10	G1/2	8,5	9	18	34	15	22	19	42
1511 15/12,5-1/2	15/12,5	G1/2	11	9	20	36	15,5	22	22	52

* = mit O-Ring montiert, zylindrisch

Gerade Einschraub-Verschraubung Mod. 1560



Sprint®, zylindrisch, drehbar

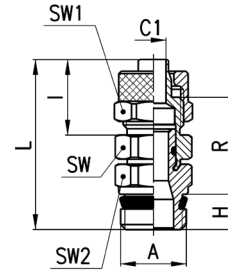

PRODUKTÜBERSICHT											
Mod.	Schlauch	A	C1	H	I	L	R	SW	SW1	SW2	Gewicht (g)
1560 6/4-1/8	6/4	G1/8	3	5,5	15	31	18	12	12	12	19
1560 6/4-1/4	6/4	G1/4	3	7	15	32,5	18	12	12	14	25
1560 8/6-1/8	8/6	G1/8	5	5,5	15	32	19	13	14	12	21
1560 8/6-1/4	8/6	G1/4	5	7	15	33,5	19	13	14	14	26
1560 10/8-1/4	10/8	G1/4	6,5	7	16,5	34,5	19	14	16	14	27
1560 10/8-3/8	10/8	G3/8	6,5	8	16,5	36	19,5	14	16	19	38
1560 12/10-3/8	12/10	G3/8	8,5	8	18	38	20	17	19	19	46

Gerade Aufschraub-Verschraubung Mod. 1463

Zylindrisch

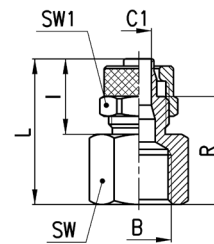

PRODUKTÜBERSICHT									
Mod.	Schlauch	B	C1	I	L	R	SW	SW1	Gewicht (g)
1463 5/3-1/8	5/3	G1/8	2	12,5	22,5	16	13	8	10
1463 6/4-1/8	6/4	G1/8	3	15	25	17,5	13	12	14
1463 6/4-1/4	6/4	G1/4	3	15	26,5	19	17	12	21
1463 6/4-3/8	6/4	G3/8	3	15	27,5	20	20	12	25
1463 8/6-1/8	8/6	G1/8	5	15	25	17,5	13	14	16
1463 8/6-1/4	8/6	G1/4	5	15	26,5	19	17	14	22
1463 8/6-3/8	8/6	G3/8	5	15	27,5	20	20	14	26
1463 10/8-1/8	10/8	G1/8	6,5	16,5	21,5	13	14	16	19
1463 10/8-1/4	10/8	G1/4	6,5	16,5	28	19,5	17	16	28
1463 10/8-3/8	10/8	G3/8	6,5	16,5	29	20,5	20	16	31
1463 10/8-1/2	10/8	G1/2	6,5	16,5	33	24,5	24	16	43
1463 12/10-3/8	12/10	G3/8	8,5	18	30,5	20,5	20	19	37

Winkel-Einschraub-Verschraubung Mod. 1541

Sprint®, zylindrisch, drehbar

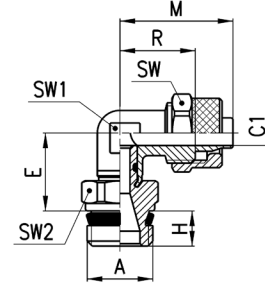

PRODUKTÜBERSICHT											
Mod.	Schlauch	A	C1	E	H	M	R	SW	SW1	SW2	Gewicht (g)
1541 6/4-1/8	6/4	G1/8	3	15	5,5	22,5	15	12	10	12	22
1541 6/4-1/4	6/4	G1/4	3	15	7	22,5	15	12	10	14	27
1541 8/6-1/8	8/6	G1/8	5	15	5,5	22,5	15	14	10	12	23
1541 8/6-1/4	8/6	G1/4	5	15	7	22,5	15	14	10	14	28
1541 10/8-1/4	10/8	G1/4	6,5	16	7	25,5	17	16	12	14	35

Winkel-Einschraub-Verschraubung Mod. 1500

Konisch

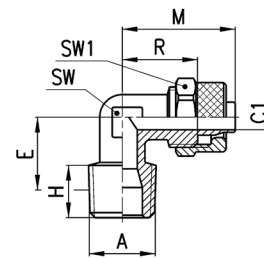

PRODUKTÜBERSICHT											
Mod.	Schlauch	A	C1	E	H	M	R	SW	SW1	Gewicht (g)	
1500 5/3-1/8	5/3	R1/8	2	13	7,5	21,5	15	8	8	11	
1500 6/4-1/8	6/4	R1/8	3	13	7,5	22,5	15	8	12	15	
1500 6/4-1/4	6/4	R1/4	3	15,5	11	22,5	15	10	12	21	
1500 6/4-3/8	6/4	R3/8	3	17	11,5	23,5	16	12	12	27	
1500 6/4-M12x1,25	6/4	M12x1,25	3	14	10	22,5	15	10	12	18	
1500 8/6-1/8	8/6	R1/8	5	13	7,5	22,5	15	10	14	19	
1500 8/6-1/4	8/6	R1/4	5	15,5	11	22,5	15	10	14	21	
1500 8/6-3/8	8/6	R3/8	5	17	11,5	24	16	12	14	29	
1500 8/6-1/2	8/6	R1/2	5	21,5	14	27	19	16	14	48	
1500 10/8-1/8	10/8	R1/8	6,5	15	7,5	25,5	17	12	16	29	
1500 10/8-1/4	10/8	R1/4	6,5	17	11	25,5	17	12	16	29	
1500 10/8-3/8	10/8	R3/8	6,5	16,5	11,5	25,5	17	12	16	33	
1500 10/8-1/2	10/8	R1/2	6,5	21	14	28,5	20	16	16	58	
1500 12/10-3/8	12/10	R3/8	8,5	19	11,5	30	20	14	19	44	
1500 12/10-1/2	12/10	R1/2	8,5	21	14	30,5	20,5	16	19	59	
1500 15/12,5-1/2	15/12,5	R1/2	11	21	14	34	22,5	16	22	67	

Winkel-Einschraub-Verschraubung Mod. 1501

Mit Dichtring montiert, zylindrisch

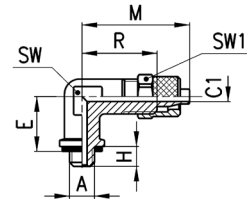
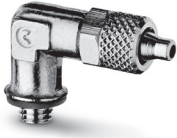

PRODUKTÜBERSICHT										
Mod.	Schlauch	A	C1	E	H	M	R	SW	SW1	Gewicht (g)
1501 5/3-M5	5/3	M5	2	11	4	21,5	15	8	8	10

Winkel-Aufschraub-Verschraubung Mod. 1493

Zylindrisch

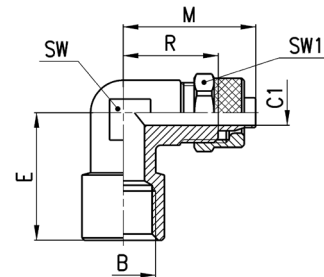

PRODUKTÜBERSICHT										
Mod.	Schlauch	B	C1	E	M	R	SW	SW1	Gewicht (g)	
1493 6/4-1/8	6/4	G1/8	3	19	22.5	15	10	12	20	
1493 6/4-1/4	6/4	G1/4	3	23,5	26	18.5	14	12	34	
1493 8/6-1/8	8/6	G1/8	5	19	22.5	15	10	14	21	
1493 8/6-1/4	8/6	G1/4	5	23,5	26	19	14	14	34	
1493 10/8-1/4	10/8	G1/4	6.5	23,5	27.5	18	14	16	39	
1493 12/10-3/8	12/10	G3/8	8.5	26	30.5	20.5	16	19	53	

T-Einschraub-Verschraubung Mod. 1431

Sprint®, zylindrisch, drehbar

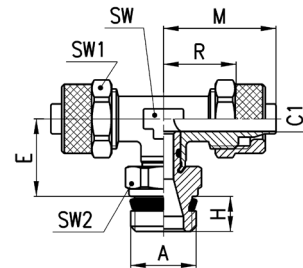

PRODUKTÜBERSICHT											
Mod.	Schlauch	A	C1	E	H	M	R	SW	SW1	SW2	Gewicht (g)
1431 6/4-1/8	6/4	G1/8	3	15	5,5	22,5	15	10	12	12	32
1431 6/4-1/4	6/4	G1/4	3	15	7	22,5	15	10	12	14	38
1431 8/6-1/8	8/6	G1/8	5	15	5,5	22,5	15	10	14	12	36
1431 8/6-1/4	8/6	G1/4	5	15	7	22,5	15	10	14	14	41
1431 10/8-1/4	10/8	G1/4	6,5	16	7	25,5	17	12	16	14	54

T-Einschraub-Verschraubung Mod. 1410

Konisch

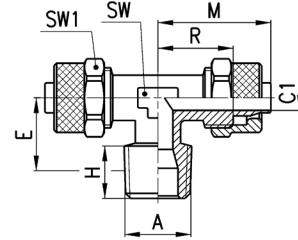

PRODUKTÜBERSICHT										
Mod.	Schlauch	A	C1	E	H	M	R	SW	SW1	Gewicht (g)
1410 5/3-1/8	5/3	R1/8	2	12,5	7,5	21,5	15	8	8	16
1410 6/4-1/8	6/4	R1/8	3	12,5	7,5	22,5	15	8	12	25
1410 6/4-1/4	6/4	R1/4	3	15,5	11	22,5	15	10	12	32
1410 8/6-1/8	8/6	R1/8	5	13	7,5	22,5	15	10	14	31
1410 8/6-1/4	8/6	R1/4	5	15,5	11	22,5	15	10	14	35
1410 10/8-1/8	10/8	R1/8	6,5	15	7,5	25,5	17	12	16	47
1410 10/8-1/4	10/8	R1/4	6,5	17	11	25,5	17	12	16	50
1410 10/8-1/2	10/8	R1/2	6,5	21,5	14	28,5	20	16	16	80
1410 12/10-3/8	12/10	R3/8	8,5	19	11,5	30	20	14	19	77
1410 12/10-1/2	12/10	R1/2	8,5	21,5	14	30,5	20,5	16	19	92
1410 15/12,5-1/2	15/12,5	R1/2	11	21,5	14	34	22,5	16	22	107

L-Einschraub-Verschraubung Mod. 1420

Konisch

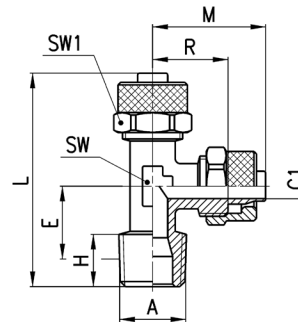

PRODUKTÜBERSICHT											
Mod.	Schlauch	A	C1	E	H	L	M	R	SW	SW1	Gewicht (g)
1420 5/3-1/8	5/3	R1/8	2	12,5	7,5	37,5	21,5	15	8	8	15
1420 6/4-1/8	6/4	R1/8	3	12,5	7,5	38,5	22,5	15	8	12	23
1420 6/4-1/4	6/4	R1/4	3	15,5	11	43	22,5	15	10	12	29
1420 8/6-1/8	8/6	R1/8	5	13	7,5	39	22,5	15	10	14	31
1420 8/6-1/4	8/6	R1/4	5	15,5	11	43	22,5	15	10	14	34
1420 10/8-1/8	10/8	R1/8	6,5	15	7,5	43,5	25,5	17	12	16	46
1420 10/8-1/4	10/8	R1/4	6,5	17	11	47	25,5	17	12	16	50

Schwenkringstück Mod. 1610

Kombinierbar mit Hohlschrauben Mod. 1631/1635

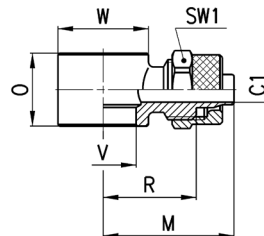

PRODUKTÜBERSICHT										
Mod.	Schlauch	C1	M	O	R	V	W	SW1	Gew. (g)	Kombinierbar mit Mod.
1610 5/3-M5	5/3	2	17	9	10.5	5.1	∅9	8	8	1631, 1635
1610 5/3-M6	5/3	2	17	9	10.5	5.1	∅9	8	7	SCU, SVU, SCO...
1610 5/3-1/8	5/3	2	22.5	14.5	16	9.8	∅14	8	13	1631, 1635, SCU, SVU, SCO...
1610 6/4-M5	6/4	3	18	9	10.5	5.1	∅9	9	8	1631, 1635
1610 6/4-M6	6/4	2	18	9	10.5	5.1	∅9	9	8	SCU, SVU, SCO...
1610 6/4-1/8	6/4	3	24	14.5	16.5	9.8	∅14	12	18	1631, 1635, SCU, SVU, SCO...
1610 6/4-1/4	6/4	3	26	14.5	18.5	13.2	∅18	12	21	1631, 1635, SCU, SVU, SCO...
1610 6/4-3/8	6/4	3	28	14.5	20.5	16.7	∅21	12	22	1631, 1635, SCU, SVU, SCO...
1610 8/6-1/8	8/6	5	24	14.5	16.5	9.8	∅14	14	19	1631, 1635, SCU, SVU, SCO...
1610 8/6-1/4	8/6	5	26	14.5	18.5	13.2	∅18	14	22	1631, 1635, SCU, SVU, SCO...
1610 8/6-3/8	8/6	5	28	14.5	20.5	16.7	∅21	14	25	1631, 1635, SCU, SVU, SCO...
1610 10/8-1/8	10/8	6.5	25	14.5	16.5	9.8	∅14	16	25	1635, SCU, SVU, SCO...
1610 10/8-1/4	10/8	6.5	27	14.5	18.5	13.2	∅18	16	24	1635, SCU, SVU, SCO...
1610 10/8-3/8	10/8	6.5	29.5	14.5	21	16.7	∅21	16	28	1635, SCU, SVU, SCO...
1610 10/8-1/2	10/8	6.5	32	14.5	23.5	21	∅26	16	35	1635
1610 12/10-3/8	12/10	8	31.5	14.5	21.5	16.7	∅21	19	36	1635, SCU, SVU, SCO...
1610 12/10-1/2	12/10	8.5	33.5	14.5	23.5	21	∅26	19	40	1635
1610 15/12,5-1/2	15/12,5	11	36.5	14.5	25	21	∅26	22	48	1635

T-Schwenkringstück Mod. 1620

Kombinierbar mit Hohlschrauben Mod. 1631/1635

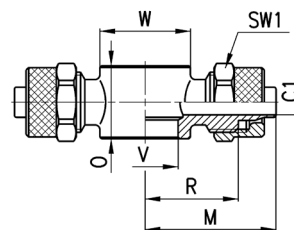

PRODUKTÜBERSICHT										
Mod.	Schlauch	C1	M	O	R	V	W	SW1	Gewicht (g)	Kombinierbar mit Mod.
1620 6/4-M5	6/4	3	18	9	10.5	5.1	∅9	9	12	1631, 1635
1620 6/4-1/8	6/4	3	24	14.5	16.5	9.8	∅14	12	29	1631, 1635, SCU, SVU, SCO...
1620 6/4-1/4	6/4	3	26	14.5	18.5	13.2	∅18	12	31	1631, 1635, SCU, SVU, SCO...
1620 8/6-1/8	8/6	5	24	14.5	16.5	9.8	∅14	14	31	1631, 1635, SCU, SVU, SCO...
1620 8/6-1/4	8/6	5	26	14.5	18.5	13.2	∅18	14	34	1631, 1635, SCU, SVU, SCO...

Hohlschraube 1-fach kurz Mod. 1631 -01



Kombinierbar mit Ringstücken Mod. 6610, 6620, 1610, 1620, 2023, 1170

Mit Dichtring montiert

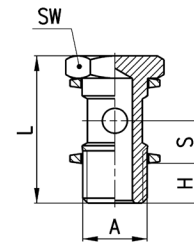

PRODUKTÜBERSICHT						
Mod.	A	H	L	S	SW	Gewicht (g)
1631 01-M5	M5	4	18	5,5	8	3 *
1631 01-1/8	G1/8	6	27	8,5	14	13
1631 01-1/4	G1/4	8	29,5	8,5	17	24
1631 01-3/8	G3/8	8	30	8,5	19	35
1631 01-1/2	G1/2	9	31	8,5	27	63

* = Stahl verzinkt

Hohlschraube 1-fach lang Mod. 1635 -01



Kombinierbar mit Ringstücken Mod. 6610, 6620, 1610, 1620, 2023, 1170

Mit Dichtring montiert

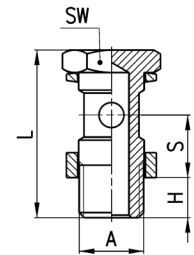

PRODUKTÜBERSICHT						
Mod.	A	H	L	S	SW	Gewicht (g)
1635 01-1/8	G1/8	6	31	12,5	14	15
1635 01-1/4	G1/4	8	33,5	12,5	17	27
1635 01-3/8	G3/8	8	34	12,5	19	37
1635 01-1/2	G1/2	9	35	12,5	27	71
1635 01-M12x1,25	M12x1,25	8	33,5	12,5	17	27 *
1635 01-M12x1,5	M12x1,5	8	33,5	12,5	17	27 *

* = Kombination mit Schwenkringstück G1/4"

Hohlschraube 2-fach kurz Mod. 1631 -02



Kombinierbar mit Ringstücken Mod. 6610, 6620, 1610, 1620, 2023, 1170

Mit Dichtring montiert

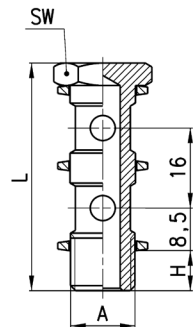

PRODUKTÜBERSICHT					
Mod.	A	H	L	SW	Gewicht (g)
1631 02-1/8	G1/8	6	43	14	18
1631 02-1/4	G1/4	8	45,5	17	33
1631 02-3/8	G3/8	8	46	19	48

Hohlschraube 2-fach lang Mod. 1635 -02



Kombinierbar mit Ringstücken Mod. 6610, 6620, 1610, 1620, 2023, 1170

Mit Dichtring montiert

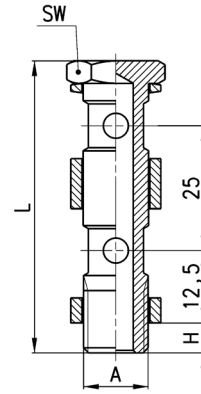

PRODUKTÜBERSICHT					
Mod.	A	H	L	SW	Gewicht (g)
1635 02-1/8	G1/8	6	56	14	26
1635 02-1/4	G1/4	8	58,5	17	33
1635 02-3/8	G3/8	8	59	19	64
1635 02-1/2	G1/2	9	60	27	111

Hohlschraube 3-fach kurz Mod. 1631 -03



Kombinierbar mit Ringstücken Mod. 6610, 6620, 1610, 1620, 2023, 1170

Mit Dichtring montiert

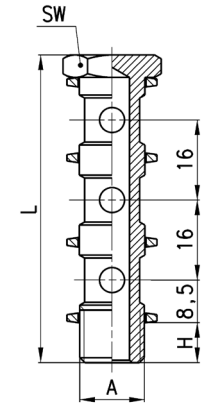

PRODUKTÜBERSICHT					
Mod.	A	H	L	SW	Gewicht (g)
1631 03-1/8	G1/8	6	59	14	24
1631 03-1/4	G1/4	8	61,5	17	42
1631 03-3/8	G3/8	8	62	19	62

Gerader Verbinder Mod. 1580

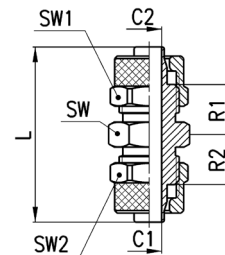

PRODUKTÜBERSICHT										
Mod.	Schlauch	C1	C2	L	R1	R2	SW	SW1	SW2	Gewicht (g)
1580 5/3	5/3	2	2	28,5	7,5	7,5	8	8	8	8
1580 6/4	6/4	3	3	34,5	10	10	12	12	12	22
1580 8/6	8/6	5	5	34,5	9,75	9,75	13	14	14	28
1580 10/8	10/8	6,5	6,5	38	10,5	10,5	14	16	16	38
1580 12/10	12/10	8,5	8,5	41	10,5	10,5	17	19	19	55
1580 15/12,5	15/12,5	11	11	45	11	11	22	22	22	80
1580 8/6-6/4	8/6-6/4	5	3	34,5	9,75	9,75	13	12	14	24
1580 10/8-6/4	10/8-6/4	6,5	3	36,5	10,5	10	14	12	16	31

Gerade Schottverschraubung Mod. 1590

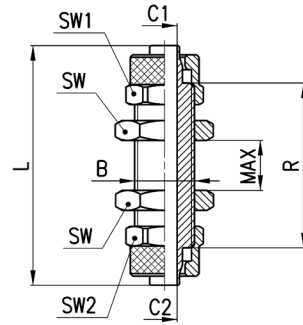

PRODUKTÜBERSICHT											
Mod.	Schlauch	B	C1	C2	L	R	MAX	SW	SW1	SW2	Gewicht (g)
1590 5/3	5/3	M7x0,75	2	2	40	27	9	8	8	8	12
1590 6/4	6/4	M10x1	3	3	48	33	14	14	12	12	33
1590 8/6	8/6	M12x1	5	5	48	33	12	17	14	14	43
1590 10/8	10/8	M14x1	6,5	6,5	48	31	10	17	16	16	52
1590 12/10	12/10	M16x1	8,5	8,5	53	33	10	19	19	19	71
1590 6/4-5/3	6/4-5/3	M10x1	3	2	48	34	14	14	12	12	33
1590 8/6-6/4	8/6-6/4	M12x1	5	3	48	33	12	17	14	14	44

Winkel-Anschluss Mod. 1550

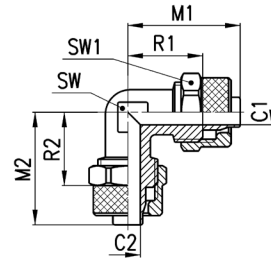

PRODUKTÜBERSICHT										
Mod.	Schlauch	C1	C2	M1	M2	R1	R2	SW	SW1	Gewicht (g)
1550 6/4	6/4	3	3	22,5	22,5	15	15	8	12	21
1550 8/6	8/6	5	5	22,5	22,5	15	15	10	14	27
1550 10/8	10/8	6,5	6,5	25,5	25,5	17	17	12	16	40
1550 12/10	12/10	8,5	8,5	30	30	20	20	14	19	61
1550 15/12,5	15/12,5	11	11	34	34	22,5	22,5	16	22	88

T-Anschluss Mod. 1540

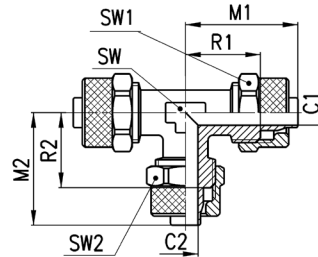

PRODUKTÜBERSICHT											
Mod.	Schlauch	C1	C2	M1	M2	R1	R2	SW	SW1	SW2	Gewicht (g)
1540 5/3	5/3	2	2	21,5	21,5	15	15	8	8	8	17
1540 6/4	6/4	3	3	22,5	22,5	15	15	8	12	12	31
1540 8/6	8/6	5	5	22,5	22,5	15	15	10	14	14	39
1540 10/8	10/8	6,5	6,5	25,5	25,5	17	17	12	16	16	58
1540 12/10	12/10	8,5	8,5	30	30	20	20	14	19	19	90
1540 15/12,5	15/12,5	11	11	34	34	22,5	22,5	16	22	22	128
1540 8/6-6/4	8/6-6/4	5	3	22,5	22,5	15	15	10	14	12	38
1540 10/8-6/4	10/8-6/4	6,5	3	25,5	23,5	17	16,5	12	16	12	50
1540 10/8-8/6	10/8-8/6	6,5	5	25,5	24	17	16,5	12	16	14	53

X-Anschluss Mod. 1600

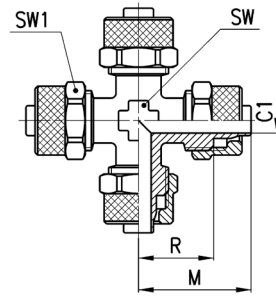

PRODUKTÜBERSICHT							
Mod.	Schlauch	C1	M	R	SW	SW1	Gewicht (g)
1600 6/4	6/4	3	22,5	15	8	12	41
1600 8/6	8/6	5	22,5	15	10	14	52

Gerade Einlöt-Verschraubung Mod. 1470

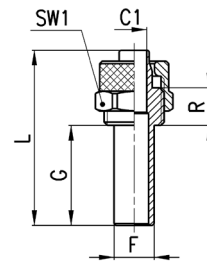

PRODUKTÜBERSICHT								
Mod.	Schlauch	F	C1	G	L	R	SW1	Gewicht (g)
1470 6/4	6/4	6	3	20	35	7,5	12	11
1470 8/6	8/6	8	5	20	35	7,5	14	15

Aluminium-Dichtring Mod. 2651



Werkstoff: Aluminium

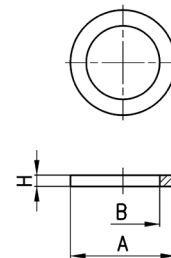

PRODUKTÜBERSICHT				
Mod.	A	B	H	Gewicht (g)
2651 1/8	14	9,8	1,5	1
2651 1/4	18	13,2	1,5	1
2651 3/8	22	16,7	1,5	1
2651 1/2	26	20,9	1,5	1
2651 1	38,5	33,4	1,5	2

Kunststoff-Dichtring Mod. 2661



Für Hohlschrauben Mod. 1631/1635
Werkstoff: Polyamid
Mit Montagesicherung

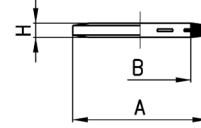

PRODUKTÜBERSICHT				
Mod.	A	B	H	Gewicht (g)
2661 M3	4,9	2,8	0,7	1
2661 M5	8	5,2	1	1
2661 M6	9	6,2	1	1
2661 1/8	14	10,2	1,9	1
2661 1/4	18	13,5	1,9	1
2661 3/8	21	16,5	2,1	1
2661 1/2	26	21,2	1,9	1

Distanz-Dichtring Mod. 2665



Für Hohlschraube lang Mod. 1635
Werkstoff: Polyamid

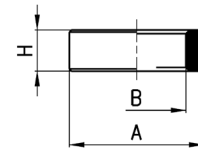

PRODUKTÜBERSICHT				
Mod.	A	B	H	Gewicht (g)
2665 1/8	14	9,8	5	1
2665 1/4	18	13,2	5	1
2665 3/8	21	16,8	5	1
2665 1/2	26	21,1	5	1

Distanz-Dichtring Mod. 2669

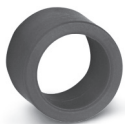

Für Hohlschraube 2-fach lang Mod. 1635-02
Werkstoff: Polyamid

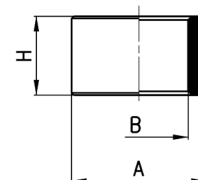

PRODUKTÜBERSICHT				
Mod.	A	B	H	Gewicht (g)
2669 1/8	14	9,8	10	1
2669 1/4	18	13,2	10	2
2669 3/8	21	16,8	10	2
2669 1/2	26	21,1	10	2

Überwurfmutter Mod. 1703

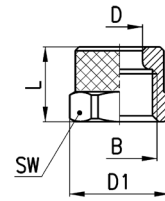

PRODUKTÜBERSICHT							
Mod.	Schlauch	B	D	D1	L	SW1	Gewicht (g)
1703 5/3-M7x0,75	5/3	M7x0,75	5,1	8,8	8,5	8	1
1703 6/4-M8x0,75	6/4	M8x0,75	6,1	9,8	8,5	9	2
1703 6/4-M10x1	6/4	M10x1	6,1	13,3	10	12	4
1703 8/6-M12x1	8/6	M12x1	8,2	15,5	10	14	5
1703 10/8-M14x1	10/8	M14x1	10,15	17,5	13	16	8
1703 12/10-M16x1	12/10	M16x1	12,2	21	13,5	19	12
1703 15/12,5-M20x1	15/12,5	M20x1	15,2	24,5	16	22	15

Knickschutzspirale Mod. 1723



Mit metallischer Feder

Bestellbezeichnung:
z.B. Mod. 1723 6/4 (ohne Gewindeangabe)

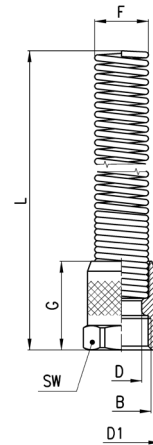

PRODUKTÜBERSICHT									
Mod.	Schlauch	B	F	D	D1	G	L	SW	Gewicht (g)
1723 6/4-M10x1	6/4	M10x1	8,9	6,1	13,3	18	90,5	12	15
1723 8/6-M12x1	8/6	M12x1	10,9	8,2	15,5	18	94,5	14	23
1723 10/8-M14x1	10/8	M14x1	12,5	10,15	17,5	22	96,5	16	29
1723 12/10-M16x1	12/10	M16x1	15,5	12,2	21	23,5	108	19	46
1723 15/12,5-M20x1	15/12,5	M20x1	18,5	15,2	24,5	28	120	22	57

Klemmringverschraubungen Universal Serie 1000

Für Kunststoffschläuche, Kupfer-, Messing-, Stahl- und Aluminiumrohre \varnothing 4, 6, 8, 10, 12 mm
Anschlüsse: G1/8", G1/4", R1/8", R1/4", R3/8", R1/2"

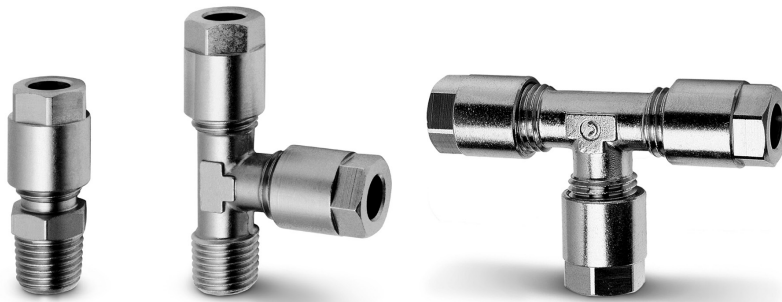

Die Klemmringverschraubungen Universal der Serie 1000 können mit den unterschiedlichsten Typen von Kunststoffschläuchen sowie mit Kupfer-, Messing-, Stahl- und Aluminiumrohren verwendet werden. Sie sind für verschiedene Anwendungen geeignet und können in der Niederdruck-Pneumatik, Ölhydraulik und in Hydraulik-Systemen eingesetzt werden.

Die Sitze der Verschraubungen, Klemmringe und Muttern entsprechen der DIN 3870-3861 Norm.

ALLGEMEINE KENNGRÖSSEN

Durchmesser	\varnothing 4, 6, 8, 10, 12 mm
Gewinde	R konisch ISO 7 (BSPT), G zylindrisch ISO 228 (BSP), andere auf Anfrage
Betriebstemperatur	schlauch-/rohr- und druckabhängig
Werkstoffe Schlauch/Rohr	Polyamid (mit Einsteckhülse Mod. 1320), Kupfer, Messing, Stahl, Aluminium
Medium	Druckluft und Niederdruckbereich für Flüssigkeiten und Gase
Werkstoffe	Körper + Überwurfmutter Messing vernickelt
Betriebsdruck	Max. 40 bar (schlauch-/rohrabhängig)

Funktionsprinzip

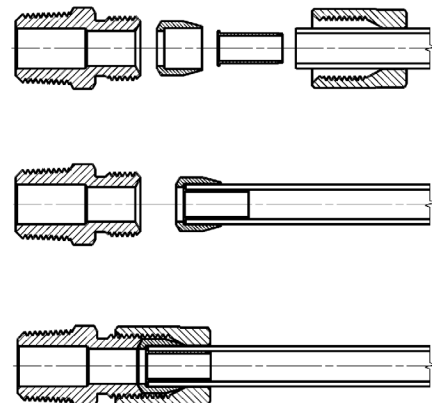

Gerade Einschraub-Verschraubung Mod. 1050



Konisch

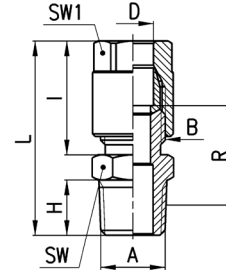

PRODUKTÜBERSICHT										
Mod.	D	A	B	H	I	L	R	SW	SW1	Gewicht (g)
1050 4-1/8	4	R1/8	1/8	7,5	19	31	14	12	12	19
1050 6-1/8	6	R1/8	1/8	7,5	19	31	14	12	12	18
1050 6-1/4	6	R1/4	1/8	11	19	35	16,5	14	12	23
1050 8-1/8	8	R1/8	1/4	7,5	23	35	15,5	14	14	29
1050 8-1/4	8	R1/4	1/4	11	23	39	18	14	14	33
1050 8-3/8	8	R3/8	1/4	11,5	23	39,5	18	17	14	40
1050 10-1/4	10	R1/4	3/8	11	25,5	41,5	18	17	17	51
1050 10-3/8	10	R3/8	3/8	11,5	25,5	42	18	17	17	55
1050 10-1/2	10	R1/2	3/8	14	25,5	45	18	22	17	65
1050 12-1/4	12	R1/4	M18x1,5	11	24,5	40,5	12	19	19	56 *
1050 12-3/8	12	R3/8	M18x1,5	11,5	24,5	41	12	19	19	58 *
1050 12-1/2	12	R1/2	M18x1,5	14	24,5	44	12	22	19	68 *

* = Klemmring mit Doppelkonus

Gerade Aufschraub-Verschraubung Mod. 1063

Zylindrisch

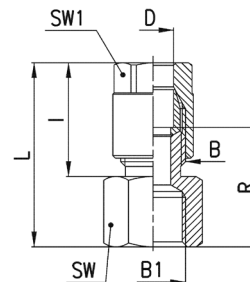

PRODUKTÜBERSICHT									
Mod.	D	B1	B	I	L	R	SW	SW1	Gewicht (g)
1063 4-1/8	4	G1/8	1/8	19	29	18,5	13	12	19
1063 6-1/8	6	G1/8	1/8	19	29	18,5	13	12	18
1063 6-1/4	6	G1/4	1/8	19	30,5	20	17	12	25
1063 8-1/8	8	G1/8	1/4	23	33	20	14	14	31
1063 8-1/4	8	G1/4	1/4	23	34,5	21,5	17	14	35

Winkel-Einschraub-Verschraubung Mod. 1020

Konisch

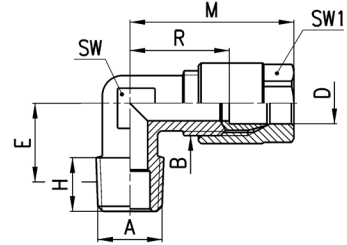

PRODUKTÜBERSICHT											
Mod.	D	A	B	E	H	M	R	SW	SW1	Gewicht (g)	
1020 4-1/8	4	R1/8	1/8	11,5	7,5	29,5	19	9	12	21	
1020 6-1/8	6	R1/8	1/8	11,5	7,5	29,5	19	9	12	19	
1020 6-1/4	6	R1/4	1/8	13,5	11	29,5	19	12	12	27	
1020 8-1/8	8	R1/8	1/4	11,5	7,5	33	20	11	14	35	
1020 8-1/4	8	R1/4	1/4	13,5	11	33	20	12	14	36	
1020 8-3/8	8	R3/8	1/4	15,5	11,5	35	22	14	14	50	
1020 10-1/4	10	R1/4	3/8	15	11	38	22,5	13	17	59	
1020 10-3/8	10	R3/8	3/8	15,5	11,5	38	22,5	14	17	58	
1020 10-1/2	10	R1/2	3/8	16	14	38	22,5	16	17	78	
1020 12-1/4	12	R1/4	M18x1,5	15	11	37	16,5	15	19	66	*
1020 12-3/8	12	R3/8	M18x1,5	15	11,5	37	16,5	15	19	66	*
1020 12-1/2	12	R1/2	M18x1,5	16	14	37	16,5	16	19	75	*

* = Klemmring mit Doppelkonus

Winkel-Aufschraub-Verschraubung Mod. 1093

Zylindrisch

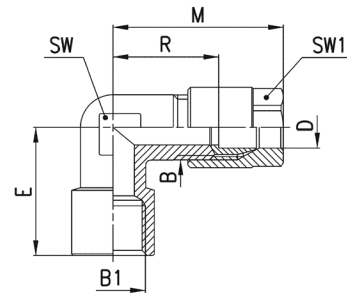

PRODUKTÜBERSICHT									
Mod.	D	B1	B	E	M	R	SW	SW1	Gewicht (g)
1093 4-1/8	4	G1/8	1/8	19	29,5	18,5	12	12	31
1093 6-1/8	6	G1/8	1/8	19	29,5	19	12	12	25
1093 6-1/4	6	G1/4	1/8	23	30,5	20	13	12	39
1093 8-1/8	8	G1/8	1/4	19	33	20	11	14	39
1093 8-1/4	8	G1/4	1/4	23	35	22	13	14	44

T-Einschraub-Verschraubung Mod. 1000

Konisch

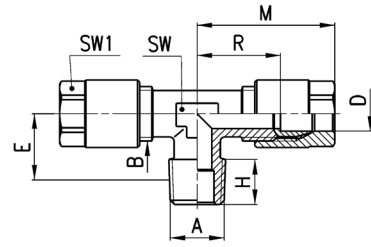

PRODUKTÜBERSICHT										
Mod.	D	A	B	E	H	M	R	SW	SW1	Gewicht (g)
1000 4-1/8	4	R1/8	1/8	11,5	7,5	29,5	19	9	12	35
1000 6-1/8	6	R1/8	1/8	11,5	7,5	29,5	19	9	12	33
1000 8-1/4	8	R1/4	1/4	13,5	11	33	20	12	14	63
1000 10-1/4	10	R1/4	3/8	15	11	38	22,5	13	17	104

L-Einschraub-Verschraubung Mod. 1010

Konisch

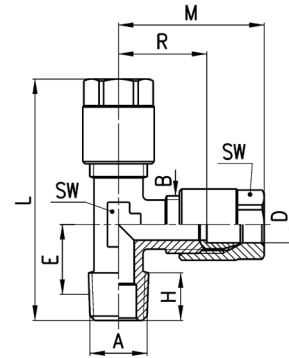

PRODUKTÜBERSICHT											
Mod.	D	A	B	E	H	L	M	R	SW	SW1	Gewicht (g)
1010 4-1/8	4	R1/8	1/8	11,5	7,5	48	29,5	19	9	12	37
1010 6-1/8	6	R1/8	1/8	11,5	7,5	48	29,5	19	9	12	33
1010 8-1/4	8	R1/4	1/4	13,5	11	54,5	33	20	12	14	61
1010 10-1/4	10	R1/4	3/8	15	11	61,5	38	22,5	13	17	103

Gerader Verbinder Mod. 1230

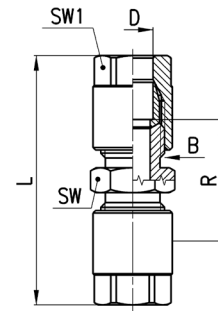

PRODUKTÜBERSICHT							
Mod.	D	B	L	R	SW	SW1	Gewicht (g)
1230 4	4	1/8	42,5	21,5	12	12	29
1230 6	6	1/8	42,5	21,5	12	12	26
1230 8	8	1/4	51	25	14	14	48
1230 10	10	3/8	56	25	17	17	83
1230 12	12	M18x1,5	54	13	19	19	140

* = Klemmring mit Doppelkonus

Gerade Schottverschraubung Mod. 1250

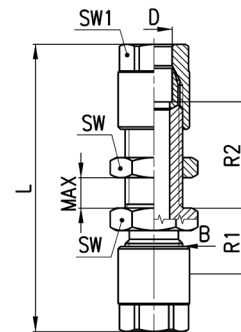

PRODUKTÜBERSICHT									
Mod.	D	B	L	R1	R2	MAX	SW	SW1	Gewicht (g)
1250 4	4	1/8	57,5	12,5	23	12	14	12	40
1250 6	6	1/8	57,5	13	23,5	12	14	12	38
1250 8	8	1/4	65	15	24	13	17	14	67
1250 10	10	3/8	72,5	15	26,5	13	22	17	119

Winkel-Anschluss Mod. 1220

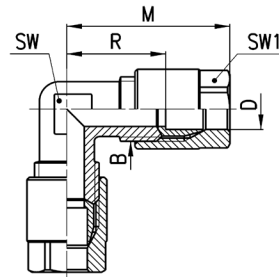

PRODUKTÜBERSICHT							
Mod.	D	B	M	R	SW	SW1	Gewicht (g)
1220 4	4	1/8	29,5	19	9	12	31
1220 6	6	1/8	29,5	19	9	12	29
1220 8	8	1/4	33	20	11	14	53
1220 10	10	3/8	38	22,5	14	17	92
1220 12	12	M18x1,5	37	16,5	16	19	99 *

* = Klemmring mit Doppelkonus

T-Anschluss Mod. 1210

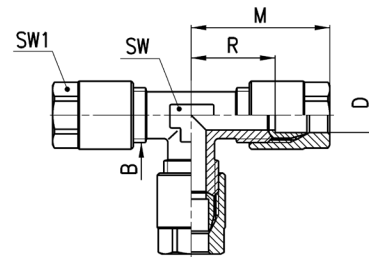

PRODUKTÜBERSICHT							
Mod.	D	B	M	R	SW	SW1	Gewicht (g)
1210 4	4	1/8	29,5	19	9	12	45
1210 6	6	1/8	29,5	19	9	12	42
1210 8	8	1/4	33	20	12	14	79
1210 10	10	3/8	38	22,5	13	17	133
1210 12	12	M18x1,5	37	16,5	16	19	144 *

* = Klemmring mit Doppelkonus

Ringstück Mod. 1170

Kombinierbar mit Hohlschrauben Mod. 1631/1635

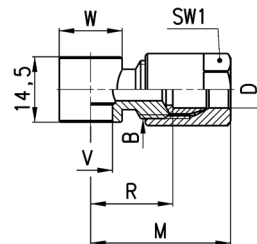

PRODUKTÜBERSICHT										
Mod.	D	B	R	M	V	W	SW1	Gewicht (g)	Kombinierbar mit Mod.	
1170 6-1/8	6	1/8	17.5	28	9.8	14	12	20	1631, 1635, SCU, SVU, SCO...	
1170 6-1/4	6	1/8	20	30.5	13.2	18	12	24	1631, 1635, SCU, SVU, SCO...	
1170 8-1/8	8	1/4	18	31	9.8	14	14	31	1635, SCU, SVU, SCO...	

Überwurfmutter Mod. 1303

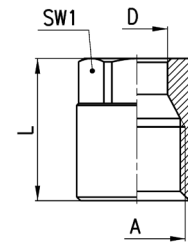

PRODUKTÜBERSICHT					
Mod.	D	A	L	SW1	Gewicht (g)
1303 4-1/8	4	1/8	15,5	12	8
1303 6-1/8	6	1/8	15,5	12	8
1303 8-1/4	8	1/4	19	14	14
1303 10-3/8	10	3/8	21,5	17	24
1303 12-M18x1,5	12	M18x1,5	19,5	19	27

Klemmring Mod. 1310

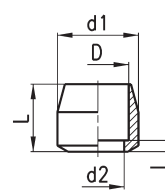

FIG. 1

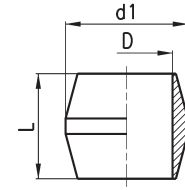
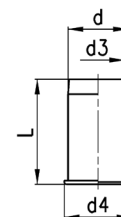

FIG. 2

PRODUKTÜBERSICHT						
Mod.	D	d1	d2	l	L	Gewicht (g)
1310 4	4	7,8	3	1	8	2
1310 6	6	7,8	4,5	1	7	1
1310 8	8	10,8	7	1,5	9	3
1310 10	10	13,8	9	1,5	11,5	5
1310 12-M18	12	16,3	12	-	11	6

* = mit Doppelkonus (Fig. 2)

Einsteckhülse Mod. 1320



PRODUKTÜBERSICHT					
Mod.	d	d3	d4	L	Gewicht (g)
1320 4	4	3	5	12	1
1320 6	6	5	7	13	1
1320 8	8	7	9	14	1
1320 10	10	9	11	16	2

Verschraubungszubehör Sprint® Serie S2000

Anschlüsse: M5, M7, G1/8", G1/4", G3/8", G1/2",
R1/8", R1/4", R3/8", R1/2"

VERSCHRAUBUNGSZUBEHÖR SPRINT® SERIE S2000



Das Verschraubungszubehör der Serie S2000 Sprint® bietet die notwendige Lösung bei der Auslegung eines pneumatischen Systems.

Alle Modelle haben auf den jeweiligen Gewinden einen PTFE-Dichtring, der beim Einschrauben abdichtet. Hiermit ist die Montage vielfach möglich und es ist kein zusätzliches Dichtmittel wie Loctite bzw. PTFE-Band notwendig. Der Zeitaufwand für die Montage wird deutlich verringert.

ALLGEMEINE KENNGRÖSSEN

Gewinde	R konisch ISO 7 (BSPT), G zylindrisch ISO 228 (BSP), M5, M7, andere auf Anfrage
Betriebstemperatur	-40°C ÷ 120°C (mod. 2541 und 2612: -20°C ÷ 80°C)
Medium	Druckluft und Niederdruckbereich für Flüssigkeiten und Gase
Werkstoffe	Körper Messing vernickelt, Gewindedichtung PTFE
Betriebsdruck	80 bar

Funktionsprinzip

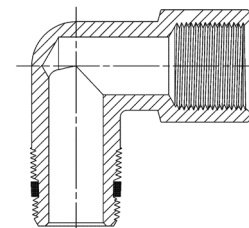

Doppelnippel Mod. S2500

Sprint®, konisch

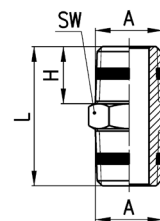

PRODUKTÜBERSICHT					
Mod.	A	H	L	SW	Gewicht (g)
S2500 1/8	R1/8	7,5	19,5	12	8
S2500 1/4	R1/4	11	27	14	15
S2500 3/8	R3/8	11,5	28	17	21
S2500 1/2	R1/2	14	33,5	22	39

Reduziernippel Mod. S2530

Sprint®, konisch/zylindrisch

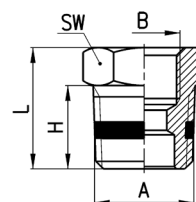

PRODUKTÜBERSICHT						
Mod.	A	B	H	L	SW	Gewicht (g)
S2530 1/4-1/8	R1/4	G1/8	11	16	14	9
S2530 3/8-1/8	R3/8	G1/8	11,5	16,5	17	16
S2530 1/2-1/8	R1/2	G1/8	14	19,5	22	13
S2530 3/8-1/4	R3/8	G1/4	11,5	16,5	17	33
S2530 1/2-1/4	R1/2	G1/4	14	19,5	22	32
S2530 1/2-3/8	R1/2	G3/8	14	19,5	22	22

Reduziernippel Mod. S2520

Sprint®, konisch/zylindrisch

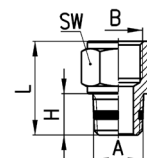

PRODUKTÜBERSICHT						
Mod.	A	B	H	L	SW	Gewicht (g)
S2520 1/8-1/8	R1/8	G1/8	7,5	17,5	13	11
S2520 1/8-1/4	R1/8	G1/4	7,5	19	17	15
S2520 1/8-3/8	R1/8	G3/8	7,5	20	20	19
S2520 1/4-1/4	R1/4	G1/4	11	22,5	17	17
S2520 1/4-3/8	R1/4	G3/8	11	23,5	20	33
S2520 1/4-1/2	R1/4	G1/2	11	27,5	24	34
S2520 3/8-3/8	R3/8	G3/8	11,5	24	20	36
S2520 3/8-1/2	R3/8	G1/2	11,5	28	24	56
S2520 1/2-1/2	R1/2	G1/2	14	30,5	24	41

Doppel-Reduziernippel Mod. S2510



Sprint®, konisch

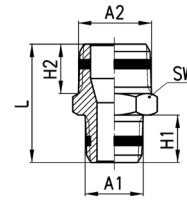

PRODUKTÜBERSICHT							
Mod.	A1	A2	H1	H2	L	SW	Gewicht (g)
S2510 1/8-1/4	R1/8	R1/4	7,5	11	23,5	14	14
S2510 1/8-3/8	R1/8	R3/8	7,5	11,5	24	17	22
S2510 1/4-3/8	R1/4	R3/8	11	11,5	27,5	17	19
S2510 1/4-1/2	R1/4	R1/2	11	14	30,5	22	33
S2510 3/8-1/2	R3/8	R1/2	11,5	14	31	22	36

Reduziernippel Mod. 2541



Sprint®, zylindrisch, drehbar

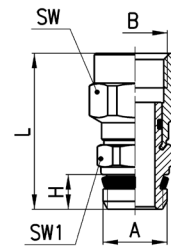

PRODUKTÜBERSICHT							
Mod.	A	B	H	L	SW	SW1	Gewicht (g)
2541 1/8-1/8	G1/8	G1/8	5,5	28	13	14	17
2541 1/4-1/4	G1/4	G1/4	7	31,5	17	14	26
2541 3/8-3/8	G3/8	G3/8	8	34	20	19	39

Winkelstück Mod. S2010



Sprint®, konisch

-20°C ÷ 80°C

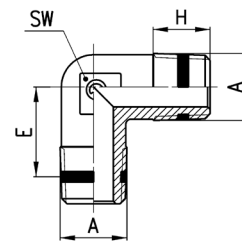

PRODUKTÜBERSICHT					
Mod.	A	E	H	SW	Gewicht (g)
S2010 1/8	R1/8	11,5	7,5	9	9
S2010 1/4	R1/4	13,5	11	12	17
S2010 3/8	R3/8	15,5	11,5	14	25
S2010 1/2	R1/2	16	14	16	47

Winkelstück Mod. S2020



Sprint®, konisch/zylindrisch

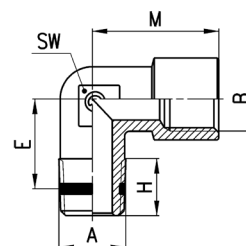

PRODUKTÜBERSICHT							
Mod.	A	B	E	H	M	SW	Gewicht (g)
S2020 1/8-1/8	R1/8	G1/8	11,5	8,5	19	11	16
S2020 1/4-1/4	R1/4	G1/4	15	11	23	13	27
S2020 3/8-3/8	R3/8	G3/8	15	11,5	25	15	33
S2020 1/2-1/2	R1/2	G1/2	17,5	14	31,5	20	62

T-Anschluss Mod. S2050

Sprint®, konisch/zylindrisch

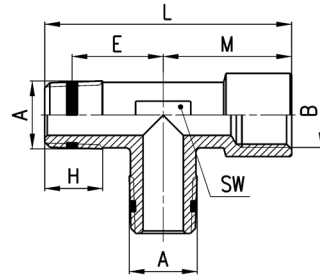

PRODUKTÜBERSICHT								
Mod.	A	B	E	H	L	M	SW	Gewicht (g)
S2050 1/8-1/8	R1/8	G1/8	11,5	8,5	37	19	12	14
S2050 1/4-1/4	R1/4	G1/4	15	11	46	23	13	44
S2050 3/8-3/8	R3/8	G3/8	15	11,5	48,5	25	16	59
S2050 1/2-1/2	R1/2	G1/2	17,5	14	60,5	31,5	20	81

T-Anschluss Mod. S2060

Sprint®, konisch/zylindrisch

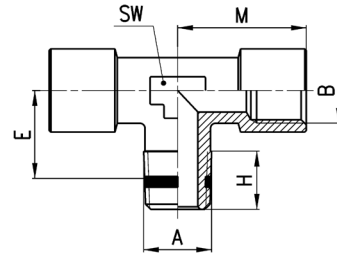

PRODUKTÜBERSICHT							
Mod.	A	B	E	H	M	SW	Gewicht (g)
S2060 1/8-1/8	R1/8	G1/8	11,5	8,5	19	12	31
S2060 1/4-1/4	R1/4	G1/4	15	11	23	13	38
S2060 3/8-3/8	R3/8	G3/8	15	11,5	25	16	51
S2060 1/2-1/2	R1/2	G1/2	17,5	14	31,5	20	88

L-Anschluss Mod. S2070

Sprint®, konisch/zylindrisch

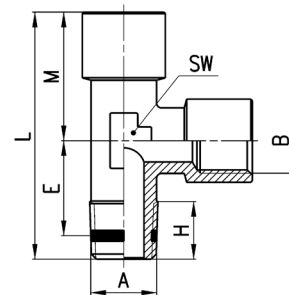

PRODUKTÜBERSICHT								
Mod.	A	B	E	H	L	M	SW	Gewicht (g)
S2070 1/8-1/8	R1/8	G1/8	11,5	8,5	37	19	12	30
S2070 1/4-1/4	R1/4	G1/4	15	11	46	23	13	36
S2070 3/8-3/8	R3/8	G3/8	15	11,5	48,5	25	16	51
S2070 1/2-1/2	R1/2	G1/2	17,5	14	60,5	31,5	20	89

T-Anschluss Mod. S2080

Sprint®, konisch

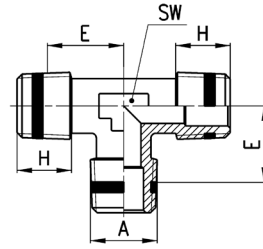

PRODUKTÜBERSICHT					
Mod.	A	E	H	SW	Gewicht (g)
S2080 1/8	R1/8	11,5	7,5	9	14
S2080 1/4	R1/4	13,5	11	12	31
S2080 3/8	R3/8	15,5	11,5	14	50
S2080 1/2	R1/2	16	14	16	63

T-Anschluss Mod. S2090

Sprint®, konisch/zylindrisch

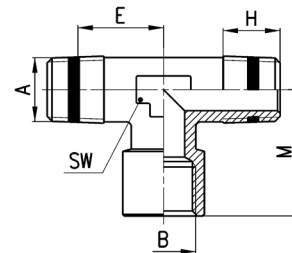

PRODUKTÜBERSICHT							
Mod.	A	B	E	H	M	SW	Gewicht (g)
S2090 1/8-1/8	R1/8	G1/8	11,5	8,5	19	12	22
S2090 1/4-1/4	R1/4	G1/4	15	11	23	13	16
S2090 3/8-3/8	R3/8	G3/8	15	11,5	25	16	59
S2090 1/2-1/2	R1/2	G1/2	17,5	14	31,5	20	80

Verschluss-Schraube Mod. 2612

mit O-Ring montiert, zylindrisch

-20°C ÷ 80°C



Neue Modelle

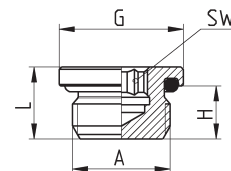

PRODUKTÜBERSICHT						
Mod.	A	G	H	L	SW	Gewicht (g)
2612 M5	M5	5.8	3.5	5.5	2	1
2612 M7	M7	9.4	5	7	4	2
2612 1/8	G1/8	13.5	6	8.5	4	5
2612 1/4	G1/4	16.4	7	9.5	6	9
2612 3/8	G3/8	20.5	7	10.5	8	17
2612 1/2	G1/2	24.8	8	11.5	12	25

Verschluss-Schraube Mod. S2610

Sprint®, zylindrisch

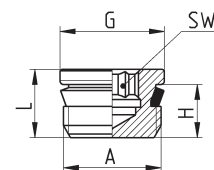

PRODUKTÜBERSICHT						
Mod.	A	G	H	L	SW	Gewicht (g)
S2610 1/8	G1/8	10.7	5.5	7.5	4	3
S2610 1/4	G1/4	13.8	7	9	6	6
S2610 3/8	G3/8	17.8	8	10	8	12
S2610 1/2	G1/2	21.8	9	11	10	21

Verschluss-Schraube Mod. S2615

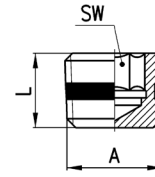

PRODUKTÜBERSICHT				
Mod.	A	L	SW	Gewicht (g)
S2615 1/8	R1/8	8	5	2
S2615 1/4	R1/4	10	7	6
S2615 3/8	R3/8	10	8	12

Verschraubungszubehör Serie 2000

Anschlüsse: M5, G1/8", G1/4", G3/8", G1/2", G3/4", G1",
R1/8", R1/4", R3/8", R1/2", R3/4", R1"



Das Verschraubungszubehör der Serie 2000 beinhaltet eine breite Palette an Muffen, Reduzierungen, Doppelnippeln, Schlauchtüllen, Winkelstücken und Verteilerblöcken. Die Produkte bieten mit ihren Kombinationsmöglichkeiten die optimale Lösung bei der Auslegung eines pneumatischen Systems.

ALLGEMEINE KENNGRÖSSEN

Gewinde	R konisch ISO 7 (BSPT), G zylindrisch ISO 228 (BSP), M5, andere auf Anfrage
Betriebstemperatur	-40°C ÷ 120°C
Medium	Druckluft und Niederdruckbereich für Flüssigkeiten und Gase
Werkstoffe	Körper Messing vernickelt
Betriebsdruck	80 bar

Funktionsprinzip

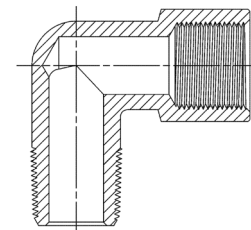

Doppelnippel Mod. 2500



Konisch

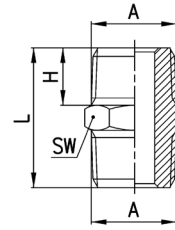

PRODUKTÜBERSICHT					
Mod.	A	H	L	SW	Gewicht (g)
2500 1/8	R1/8	7,5	19,5	12	9
2500 1/4	R1/4	11	27	14	16
2500 3/8	R3/8	11,5	28	17	21
2500 1/2	R1/2	14	33,5	22	41
2500 3/4	R3/4	16,5	40	27	80
2500 1	R1	19	45,5	34	125

Doppelnippel Mod. 2501



Zylindrisch

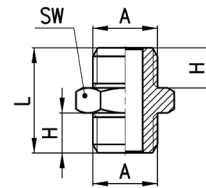

PRODUKTÜBERSICHT					
Mod.	A	H	L	SW	Gewicht (g)
2501 M5	M5	4	11,5	8	2
2501 1/8	G1/8	6	16,5	13	9
2501 1/4	G1/4	8	21	17	15
2501 3/8	G3/8	9	23	19	21
2501 1/2	G1/2	10	25,5	24	35

Doppel-Reduziernippel Mod. 2510



Konisch

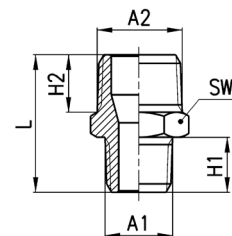

PRODUKTÜBERSICHT							
Mod.	A1	A2	H2	H1	L	SW	Gewicht (g)
2510 1/8-1/4	R1/8	R1/4	11	7,5	23,5	14	14
2510 1/8-3/8	R1/8	R3/8	11,5	7,5	24	17	18
2510 1/4-3/8	R1/4	R3/8	11,5	11	27,5	17	20
2510 1/4-1/2	R1/4	R1/2	14	11	30,5	22	34
2510 3/8-1/2	R3/8	R1/2	14	11,5	31	22	34
2510 1/2-3/4	R1/2	R3/4	16,5	14	37,5	27	67

Verlängerungs-/Reduziernippel Mod. 2520

Konisch/zylindrisch

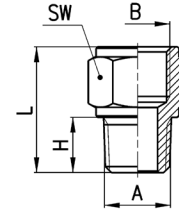

PRODUKTÜBERSICHT						
Mod.	A	B	H	L	SW	Gewicht (g)
2520 1/8-1/8	R1/8	G1/8	7,5	17,5	13	9
2520 1/8-1/4	R1/8	G1/4	7,5	19	17	15
2520 1/8-3/8	R1/8	G3/8	7,5	20	20	19
2520 1/4-1/4	R1/4	G1/4	11	22,5	17	17
2520 1/4-3/8	R1/4	G3/8	11	23,5	20	21
2520 1/4-1/2	R1/4	G1/2	11	27,5	24	35
2520 3/8-3/8	R3/8	G3/8	11,5	24	20	23
2520 3/8-1/2	R3/8	G1/2	11,5	28	24	37
2520 1/2-1/2	R1/2	G1/2	14	30,5	24	41

Verlängerungs-/Reduziernippel Mod. 2521

Zylindrisch

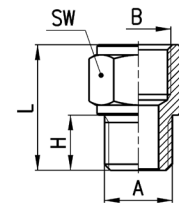

PRODUKTÜBERSICHT						
Mod.	A	B	H	L	SW	Gewicht (g)
2521 M5-1/8	M5	G1/8	4	14	13	7
2521 1/8-1/8	G1/8	G1/8	6	16	13	8
2521 1/8-1/4	G1/8	G1/4	6	17,5	17	14
2521 1/8-3/8	G1/8	G3/8	6	18,5	20	30
2521 1/4-1/4	G1/4	G1/4	8	19,5	17	16
2521 1/4-3/8	G1/4	G3/8	8	20,5	20	20
2521 1/4-1/2	G1/4	G1/2	8	24,5	24	33
2521 3/8-3/8	G3/8	G3/8	9	21,5	20	22
2521 3/8-1/2	G3/8	G1/2	9	25,5	24	35
2521 1/2-1/2	G1/2	G1/2	10	26,5	24	36

Doppel-Reduziernippel Mod. 2511

Zylindrisch

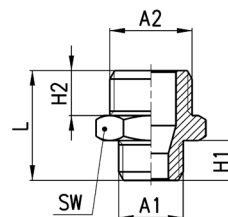

PRODUKTÜBERSICHT							
Mod.	A1	A2	H1	H2	L	SW	Gewicht (g)
2511 M5-1/8	M5	G1/8	4	6	14,5	13	8
2511 1/8-1/4	G1/8	G1/4	6	8	19	17	15
2511 1/8-3/8	G1/8	G3/8	6	9	20	19	19
2511 1/4-3/8	G1/4	G3/8	8	9	22	19	20
2511 1/4-1/2	G1/4	G1/2	8	10	23,5	24	32
2511 3/8-1/2	G3/8	G1/2	9	10	24,5	24	34

Distanznippel Mod. 2525

Zylindrisch

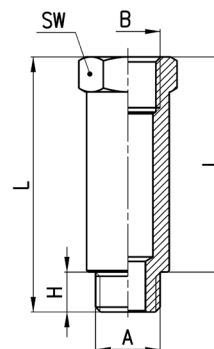

PRODUKTÜBERSICHT							
Mod.	A	B	H	I	L	SW	Gewicht (g)
2525 1/8-16	G1/8	G1/8	6	16	22	13	12
2525 1/8-36	G1/8	G1/8	6	36	42	13	24
2525 1/4-27	G1/4	G1/4	8	27	35	17	30
2525 1/4-43	G1/4	G1/4	8	43	51	17	45

Reduziernippel Mod. 2530

Konisch/zylindrisch

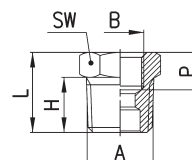

PRODUKTÜBERSICHT							
Mod.	A	B	H	P (min)	L	SW	Gewicht (g)
2530 1/4-1/8	R1/4	G1/8	11	6	16	14	9
2530 3/8-1/8	R3/8	G1/8	11,5	8,5	16,5	17	17
2530 1/2-1/8	R1/2	G1/8	14	9,5	19,5	22	12
2530 3/8-1/4	R3/8	G1/4	11,5	7	16,5	17	34
2530 1/2-1/4	R1/2	G1/4	14	9,5	19,5	22	30
2530 1/2-3/8	R1/2	G3/8	14	8	19,5	22	24
2530 3/4-3/8	R3/4	G3/8	16,5	11,5	23	27	67
2530 3/4-1/2	R3/4	G1/2	16,5	9,5	23,5	27	48
2530 1-1/2	R1	G1/2	19	14	27	34	131

Reduziernippel Mod. 2531

Zylindrisch

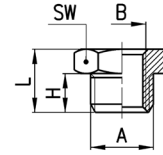

PRODUKTÜBERSICHT						
Mod.	A	B	H	L	SW	Gewicht (g)
2531 1/8-M5	G1/8	M5	6	10,5	13	8 *
2531 1/4-1/8	G1/4	G1/8	8	13	17	11 *
2531 3/8-1/8	G3/8	G1/8	9	14	19	17
2531 3/8-1/4	G3/8	G1/4	9	14	19	12 *
2531 1/2-1/8	G1/2	G1/8	10	15,5	24	32
2531 1/2-1/4	G1/2	G1/4	10	15,5	24	29
2531 1/2-3/8	G1/2	G3/8	10	15,5	24	22 *

* = durchgehendes Innengewinde

Reduziernippel Mod. 2561

Neu

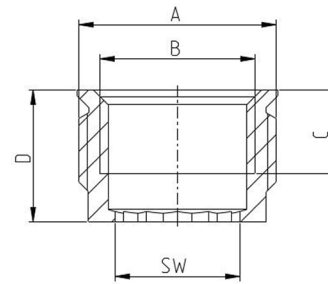

Mod.	A	B	C	D	SW
2561 1/4-1/8	G1/4	G1/8	7	9	6
2561 3/8-1/4	G3/8	G1/4	7	9	8
2561 1/2-3/8	G1/2	G3/8	9	11	10
2561 3/4-1/2	G3/4	G1/2	11	13	12
2561 1-3/4	G1	G3/4	12,5	15	17

Muffe Mod. 2543

Zylindrisch

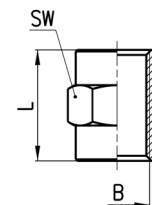

PRODUKTÜBERSICHT				
Mod.	B	L	SW	Gewicht (g)
2543 M5	M5	11	8	3
2543 1/8	G1/8	15	13	8
2543 1/4	G1/4	22	17	19
2543 3/8	G3/8	23	20	19
2543 1/2	G1/2	28	24	29

Reduziermuffe Mod. 2553

Zylindrisch

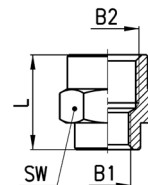

PRODUKTÜBERSICHT					
Mod.	B1	B2	L	SW	Gewicht (g)
2553 M5-1/8	M5	G1/8	13.5	13	7
2553 1/8-1/4	G1/8	G1/4	17	17	18
2553 1/8-3/8	G1/8	G3/8	18	20	18
2553 1/8-1/2	G1/8	G1/2	21.5	24	28
2553 1/4-3/8	G1/4	G3/8	21.5	20	21
2553 1/4-1/2	G1/4	G1/2	23	24	32
2553 3/8-1/2	G3/8	G1/2	24	24	31

Reduziermuffe Mod. 2593

Neu

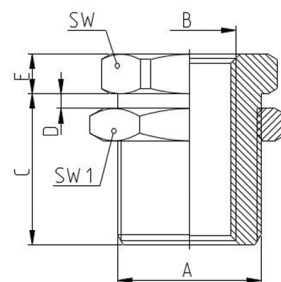

Mod.	A	B	C	D	E	SW	SW1
2593 M5-M10X1	M10x1	M5	10,5	7	3,5	14	14
2593 1/8-M16X1	M16x1	G1/8	14	10	4	19	22
2593 1/4-M20X1	M20x1,5	G1/4	21	16	4	24	27
2593 3/8-M26X1,5	M26x1,5	G3/8	21	15	5	30	32
2593 1/2-M28X1,5	M28x1,5	G1/2	27	21	6	32	36

Verschluss-Schraube Mod. 2611

Zylindrisch

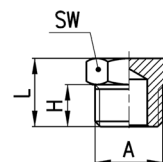

PRODUKTÜBERSICHT					
Mod.	A	H	L	SW	Gewicht (g)
2611 M5	M5	4	7,5	8	2
2611 1/8	G1/8	6	10,5	13	7
2611 1/4	G1/4	8	13	17	13
2611 3/8	G3/8	9	14	19	18
2611 1/2	G1/2	10	15,5	24	31
2611 1	G1	13	19	38	76

Verschluss-Schraube Mod. 2610 3/4

Konisch

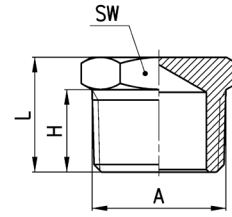

Mod.	A	H	L	SW	Gewicht (g)
2610 3/4	R3/4	16,5	23	27	61

Verschlussmutter Mod. 2613

Zylindrisch

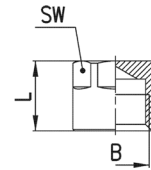

Mod.	B	L	SW	Gewicht (g)
2613 1/8	G1/8	11	12	6
2613 1/4	G1/4	13,5	15	13
2613 3/8	G3/8	15,5	18	19
2613 1/2	G1/2	22,5	19	33

Einschraub-Schlauchtülle Mod. 2601

Zylindrisch

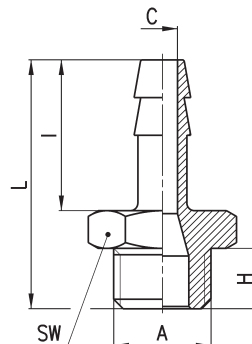

PRODUKTÜBERSICHT									
Mod.	N	A	C	H	I	L	SW	Gewicht (g)	
2601 2-M5	2	M5	1,2	4	8	16	8	2	
2601 4,5-M5	4	M5	2,5	4	15	23	8	3	
2601 7-1/8	7	G1/8	4	6	20	30	12	9	
2601 7-1/4	7	G1/4	4	8	20	33	17	16	
2601 8-1/8	8	G1/8	5	6	20	30	12	10	
2601 9-1/8	9	G1/8	5,5	6	20	30	12	11	
2601 9-1/4	9	G1/4	6	8	20	33	17	17	
2601 9-3/8	9	G3/8	6	9	20	34	19	21	
2601 12-1/4	12	G1/4	8,5	8	20	33	17	20	
2601 12-3/8	12	G3/8	9	9	20	34	19	23	
2601 12-1/2	12	G1/2	9	10	20	35,5	24	34	
2601 17-3/8	17	G3/8	12	9	24	38	19	31	
2601 17-1/2	17	G1/2	13	10	24	39,5	24	41	

Winkelstück Mod. 2013

Zylindrisch

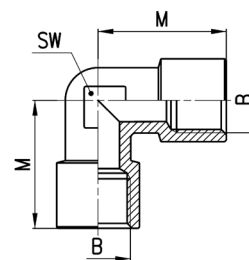

PRODUKTÜBERSICHT				
Mod.	B	M	SW	Gewicht (g)
2013 1/8	G1/8	19	11	16
2013 1/4	G1/4	23	14	28
2013 3/8	G3/8	25	16	39
2013 1/2	G1/2	31,5	20	69

Winkelstück Mod. 2010

Konisch

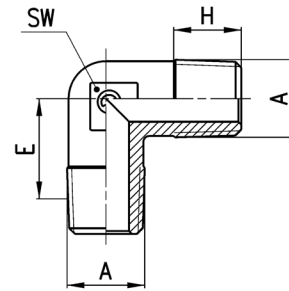

PRODUKTÜBERSICHT					
Mod.	A	E	H	SW	Gewicht (g)
2010 1/8	R1/8	11,5	7,5	9	10
2010 1/4	R1/4	13,5	11	12	18
2010 3/8	R3/8	15,5	11,5	14	28
2010 1/2	R1/2	16	14	16	47
2010 3/4	R3/4	19	16	25	103
2010 1	R1	23	17	30	183

Winkelstück Mod. 2021, Mod. 2020

Konisch/zylindrisch

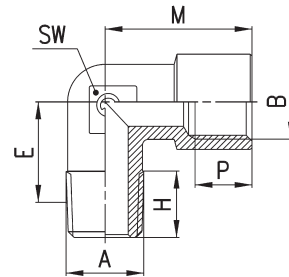

PRODUKTÜBERSICHT								
Mod.	A	B	E	H	M	P (min)	SW	Gewicht (g)
2021 M5-M5	M5	M5	9	4	10,5	4,5	9	7
2020 1/8-1/8	R1/8	G1/8	11,5	8,5	19	6	11	17
2020 1/4-1/4	R1/4	G1/4	15	11	23	7	13	27
2020 3/8-3/8	R3/8	G3/8	15	11,5	25	8	15	33
2020 1/2-1/2	R1/2	G1/2	17,5	14	31,5	9,5	20	63
2020 3/4-3/4	R3/4	G3/4	19	16	36,5	16,5	25	126
2020 1-1	R1	G1	23	17	45	19	30	209

T-Anschluss Mod. 2050

Konisch/zylindrisch

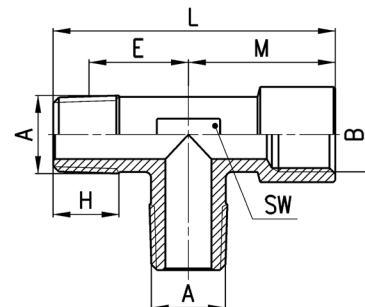

PRODUKTÜBERSICHT								
Mod.	A	B	E	H	L	M	SW	Gewicht (g)
2050 1/8-1/8	R1/8	G1/8	11,5	8,5	37	19	12	27
2050 1/4-1/4	R1/4	G1/4	15	11	46	23	13	35
2050 3/8-3/8	R3/8	G3/8	15	11,5	48,5	25	16	44
2050 1/2-1/2	R1/2	G1/2	17,5	14	60,5	31,5	20	83

T-Anschluss Mod. 2060

Konisch/zylindrisch

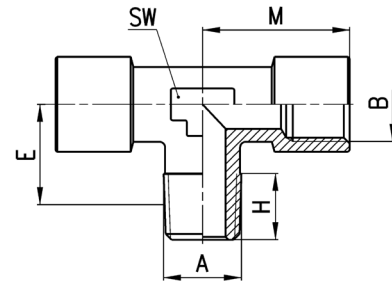

PRODUKTÜBERSICHT							
Mod.	A	B	E	H	M	SW	Gewicht (g)
2060 1/8-1/8	R1/8	G1/8	11,5	8,5	19	12	22
2060 1/4-1/4	R1/4	G1/4	15	11	23	13	38
2060 3/8-3/8	R3/8	G3/8	15	11,5	25	16	49
2060 1/2-1/2	R1/2	G1/2	17,5	14	31,5	20	89

T-Anschluss Mod. 2080

Konisch

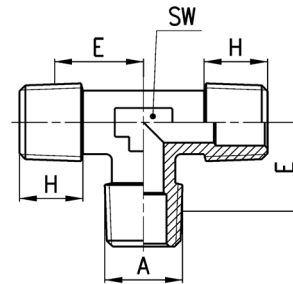

PRODUKTÜBERSICHT					
Mod.	A	E	H	SW	Gewicht (g)
2080 1/8	R1/8	11,5	7,5	9	14
2080 1/4	R1/4	13,5	11	12	25
2080 3/8	R3/8	15,5	11,5	14	39
2080 1/2	R1/2	16	14	16	82
2080 3/4	R3/4	19	16,2	25	135
2080 1	R1	23	17,5	30	239

T-Anschluss Mod. 2070

Konisch/zylindrisch

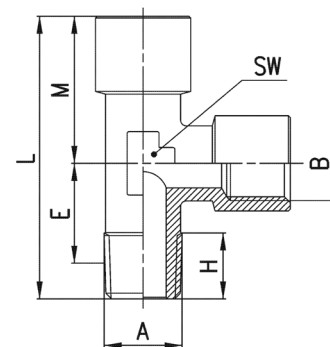

PRODUKTÜBERSICHT								
Mod.	A	B	E	H	L	M	SW	Gewicht (g)
2070 1/8-1/8	R1/8	G1/8	11,5	8,5	37	19	12	22
2070 1/4-1/4	R1/4	G1/4	15	11	46	23	13	37
2070 3/8-3/8	R3/8	G3/8	15	11,5	48,5	25	16	49
2070 1/2-1/2	R1/2	G1/2	17,5	14	60,5	31,5	20	89

T-Stück Mod. 2090

Konisch/zylindrisch

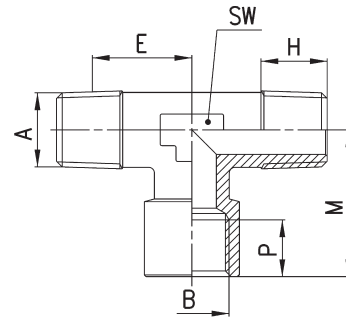

PRODUKTÜBERSICHT								
Mod.	A	B	E	H	M	P	SW	Gewicht (g)
2090 1/8-1/8	R1/8	G1/8	11,5	8,5	19	6	12	22
2090 1/4-1/4	R1/4	G1/4	15	11	23	7	13	37
2090 3/8-3/8	R3/8	G3/8	15	11,5	25	8	16	44
2090 1/2-1/2	R1/2	G1/2	17,5	14	31,5	9,5	20	83
2090 3/4-3/4	R3/4	G3/4	19	16	36,5	16,5	25	156
2090 1-1	R1	G1	23	17,5	45	19	30	262

T-Anschluss Mod. 2003

Zylindrisch

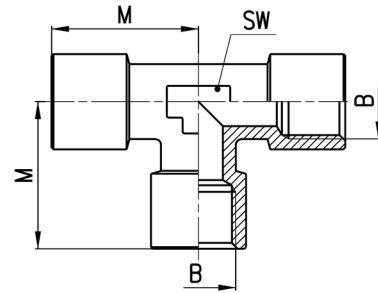

PRODUKTÜBERSICHT				
Mod.	B	M	SW	Gewicht (g)
2003 1/8	G1/8	19	12	23
2003 1/4	G1/4	23	13	39
2003 3/8	G3/8	25	16	54
2003 1/2	G1/2	31,5	20	97

Y-Stück Mod. 2040

Konisch/zylindrisch

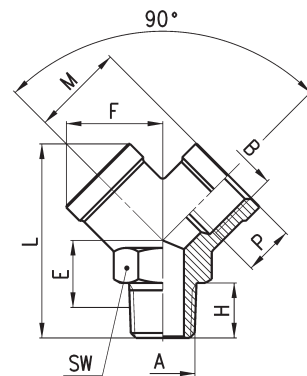

PRODUKTÜBERSICHT										
Mod.	A	B	E	F	H	L	M	P	SW	Gewicht (g)
2040 1/8-1/8	R1/8	G1/8	9,5	14,5	8	32	14	8	13	22
2040 1/4-1/4	R1/4	G1/4	12	18	11	38	17,5	11	17	38
2040 3/8-3/8	R3/8	G3/8	13,5	20,5	11,5	42,5	19	11,5	20	52
2040 1/2-1/2	R1/2	G1/2	15,5	26,5	14	53	24,5	14	25	110

Y-Stück Mod. 2043

Zylindrisch

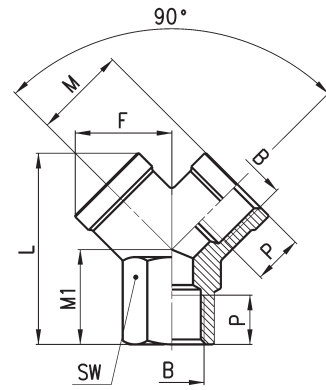

PRODUKTÜBERSICHT								
Mod.	B	F	L	M	M1	P	SW	Gewicht (g)
2043 1/8	G1/8	14,5	26,5	14	12	8	13	18
2043 1/4	G1/4	18	32	17,5	14	11	17	32
2043 3/8	G3/8	20,5	37	19	16	11,5	20	44
2043 1/2	G1/2	26,5	45	24,5	19	14	25	84

X-Stück Mod. 2033

Zylindrisch

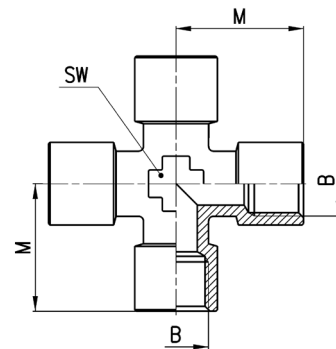

PRODUKTÜBERSICHT				
Mod.	B	M	SW	Gewicht (g)
2033 1/8	G1/8	19	12	27
2033 1/4	G1/4	23	14	51
2033 3/8	G3/8	25	16	70

Schwenkringstück Mod. 2023

Zylindrisch
Kombinierbar mit Hohlschrauben Mod. 1631/1635

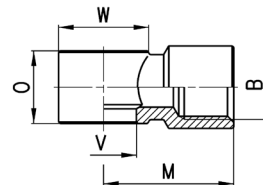

PRODUKTÜBERSICHT							
Mod.	B	M	O	V	W	Gewicht (g)	Kombinierbar mit Mod.
2023 M5-M5	M5	10.5	9	5.1	9	6	1631
2023 M5-M6	M5	10.5	9	5.1	9	6	SCU, SVU, SCO...
2023 1/8-1/8	G1/8	20	14.5	9.8	∅ 14	14	1631, 1635, SCU, SVU, SCO...
2023 1/4-1/4	G1/4	23.5	14.5	13.2	∅ 18	21	1635, SCU, SVU, SCO...
2023 3/8-3/8	G3/8	26.5	14.5	16.7	∅ 21	27	1635, SCU, SVU, SCO...

Kreuz-Verteiler Mod. 3033

Werkstoff: Aluminium eloxiert

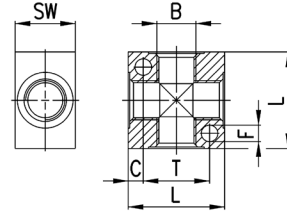

PRODUKTÜBERSICHT							
Mod.	B	C	F	L	T	SW	Gewicht (g)
3033 1/8	G1/8	4	4,5	25	17	16	18
3033 1/4	G1/4	5	5,5	32	22	20	35
3033 3/8	G3/8	7	5,5	40	26	25	73
3033 1/2	G1/2	8	5,5	50	34	30	137

Verteilerblock, Abgänge beidseitig, Mod. 3043

Werkstoff: Aluminium eloxiert

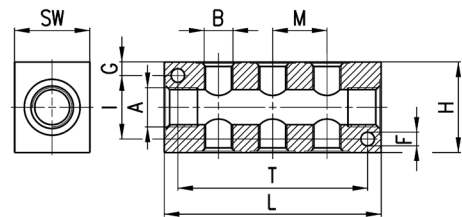

PRODUKTÜBERSICHT												
Mod.	A	ABGÄNGE BEIDSEITIG	B	F	G	H	I	L	M	T	SW	Gewicht (g)
3043 1/4-3D-1/8	G1/4	3	G1/8	4.5	4.5	30	21	72	18	63	20	85
3043 1/4-4D-1/8	G1/4	4	G1/8	4.5	4.5	30	21	90	18	81	20	107
3043 1/4-5D-1/8	G1/4	5	G1/8	4.5	4.5	30	21	108	18	99	20	128
3043 1/4-6D-1/8	G1/4	6	G1/8	4.5	4.5	30	21	126	18	117	20	151
3043 3/8-3D-1/4	G3/8	3	G1/4	5.5	6	40	28	92	24	75	25	177
3043 3/8-4D-1/4	G3/8	4	G1/4	5.5	6	40	28	116	24	99	25	224
3043 3/8-5D-1/4	G3/8	5	G1/4	5.5	6	40	28	140	24	123	25	270
3043 3/8-6D-1/4	G3/8	6	G1/4	5.5	6	40	28	164	24	147	25	315
3043 1/2-3D-3/8	G1/2	3	G3/8	5.5	6.5	50	37	104	26	85	30	287
3043 1/2-4D-3/8	G1/2	4	G3/8	5.5	6.5	50	37	130	26	111	30	356
3043 1/2-5D-3/8	G1/2	5	G3/8	5.5	6.5	50	37	156	26	137	30	427
3043 1/2-6D-3/8	G1/2	6	G3/8	5.5	6.5	50	37	182	26	163	30	495

Verteilerblock, Abgänge seitlich, Mod. 3053

Werkstoff: Aluminium eloxiert

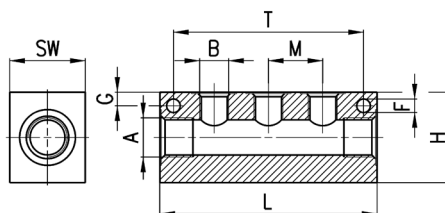

PRODUKTÜBERSICHT											
Mod.	A	Anzahl Abgänge	B	F	G	H	L	M	T	SW	Gewicht (g)
3053 1/4-3L-1/8	G1/4	3	G1/8	4,5	4,5	30	72	18	63	20	92
3053 1/4-4L-1/8	G1/4	4	G1/8	4,5	4,5	30	90	18	81	20	116
3053 1/4-5L-1/8	G1/4	5	G1/8	4,5	4,5	30	108	18	99	20	140
3053 1/4-6L-1/8	G1/4	6	G1/8	4,5	4,5	30	126	18	117	20	164
3053 3/8-3L-1/4	G3/8	3	G1/4	5,5	6	40	92	24	75	25	191
3053 3/8-4L-1/4	G3/8	4	G1/4	5,5	6	40	116	24	99	25	243
3053 3/8-5L-1/4	G3/8	5	G1/4	5,5	6	40	140	24	123	25	294
3053 3/8-6L-1/4	G3/8	6	G1/4	5,5	6	40	164	24	147	25	345
3053 1/2-3L-3/8	G1/2	3	G3/8	5,5	6,5	50	104	26	85	30	313
3053 1/2-4L-3/8	G1/2	4	G3/8	5,5	6,5	50	130	26	111	30	395
3053 1/2-5L-3/8	G1/2	5	G3/8	5,5	6,5	50	156	26	137	30	474
3053 1/2-6L-3/8	G1/2	6	G3/8	5,5	6,5	50	182	26	163	30	551

Einpress-Patrone Mod. 3053

Neu

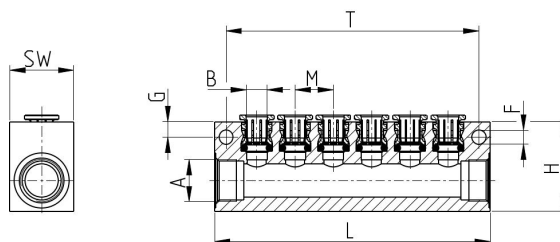

Mod.	A	ANZAHL ABGÄNGE	B	L	G	M	T	H	F	SW	Gewicht (g)
3053 1/4-8L-4	G1/4	8	4	97	4,5	10	88	30	4,5	20	140
3053 1/4-8L-6	G1/4	8	6	120	4,5	13	111	30	4,5	20	172
3053 3/8-6L-8	G3/8	6	8	108	6	15	99	35	5,5	25	210
3053 1/2-6L-10	G1/2	6	10	127	6,5	17	118	45	5,5	30	365

Einhandkupplungen Serie 5000

Selbstabsperrend, \varnothing 5 und 7 mm
Kunststoffschläuche: 6/4, 8/6, 10/8 mm
Gummischläuche: 6x14, 8x17, 10x19, 13x23 mm
Anschlüsse: G1/8", G1/4", G3/8", G1/2"



Die Einhandkupplungen der Serie 5000 sind für Anwendungen geeignet, in denen das Rohr aus konstruktionsbedingten oder sicherheitstechnischen Gründen mehrfach gelöst und verbunden werden muss. Diese Operationen können, aufgrund des Konstruktionsprinzips der Verschraubung, ohne vorherige Druckentlastung des Systems erfolgen.

Kombinationsmöglichkeiten:
Dosen Nennweite 5 mm mit Nippel
Nennweite 5 mm
Dosen Nennweite 7 mm mit Nippel
Nennweite 7 mm

Einhandkupplungen der Serie 5000 Mini mit DN5 sind kompatibel mit der Rectus Serie 21-90 und Legris Serie 21.

Einhandkupplungen der Serie 5000 nach europäischem Standard mit DN7 sind kompatibel mit der Cejn Serie 320.

ALLGEMEINE KENNGRÖSSEN

Nennweite	\varnothing 5, 7 mm
Bauart	Sitzventil mit Stecknippel
Funktion	Kupplung mit Absperrfunktion
Befestigungsart	Gewinde
Gewinde	G zylindrisch ISO 228 (BSP), andere auf Anfrage
Anschlüsse	G1/8", G1/4", G3/8", G1/2" 6/4, 8/6, 10/8, 6x14, 8x17, 10x19, 13x23
Betriebstemperatur	0°C ÷ 80°C (getrocknete Luft -20°C)
Nominaldruck	6 bar
Betriebsdruck	-0,99 ÷ 12 bar
Durchfluss	Siehe Diagramm
Medium	Druckluft (andere Medien auf Anfrage)
Werkstoffe	Körper Messing vernickelt, Feder/Kugel Edelstahl, O-Ring NBR

Funktionsprinzip

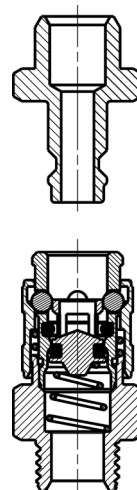

Durchflussdiagramm

Dieses Diagramm gibt Ihnen die Möglichkeit, den Durchfluss in Abhängigkeit zum Druck der beiden Nennweiten $\varnothing 5$ und 7 mm zu ermitteln. Zur Ermittlung von Q_n wurden die Modelle verwendet, welche im Diagramm aufgeführt sind. Bei Verwendung von Schläuchen und Rohren mit geringerem Innendurchmesser d als Nennweite $\varnothing 5$ bzw. 7 ergeben sich entsprechend reduzierte Werte.

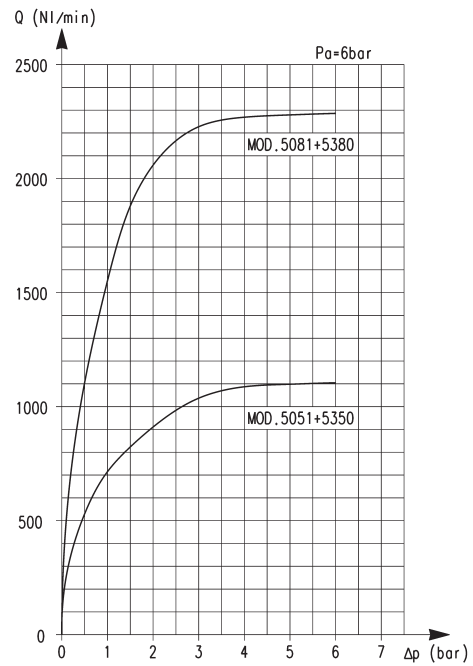

Kupplungsdose Mod. 5051 Mini und Mod. 5081 EU Standard



Zylindrisch

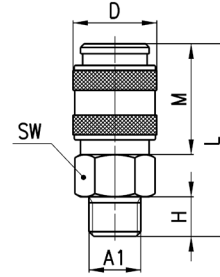

PRODUKTÜBERSICHT								
Mod.	A1	∅	D	H	L	M	SW	Gewicht (g)
5051 1/8	G1/8	5	17	6	35	20,5	14	28
5051 1/4	G1/4	5	17	8	37	20,5	17	37
5081 1/4	G1/4	7	25	8	47,5	34,5	22	93
5081 3/8	G3/8	7	25	9	48,5	34,5	22	92
5081 1/2	G1/2	7	25	10	49,5	34,5	24	107

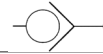

Kupplungsdose Mod. 5052 Mini und Mod. 5082 EU Standard



Zylindrisch

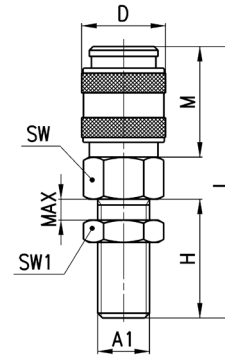

PRODUKTÜBERSICHT										
Mod.	A1	∅	D	H	L	M	max	SW	SW1	Gewicht (g)
5052 1/8	G1/8	5	17	23	52	20,5	12	14	14	38
5052 1/4	G1/4	5	17	24	53	20,5	12	17	17	52
5082 1/4	G1/4	7	25	24	63,5	34,5	12	22	17	103

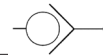

Kupplungsdose Mod. 5053 Mini und Mod. 5083 EU Standard



Zylindrisch

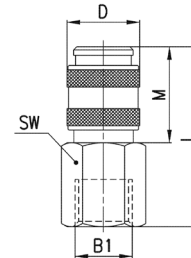

PRODUKTÜBERSICHT							
Mod.	B1	∅	D	L	M	SW	Gewicht (g)
5053 1/8	G1/8	5	17	37,5	20,5	14	33
5053 1/4	G1/4	5	17	39,5	20,5	17	44
5083 1/4	G1/4	7	25	47,5	34,5	17	88
5083 3/8	G3/8	7	25	49	34,5	20	93
5083 1/2	G1/2	7	25	53	34,5	24	103

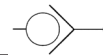

Kupplungsdose Mod. 5054 Mini und Mod. 5084 EU Standard

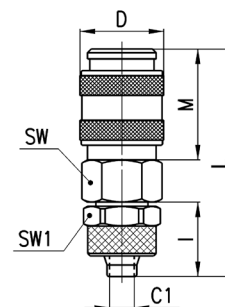

PRODUKTÜBERSICHT										
Mod.	Schlauch	∅	C1	D	I	L	M	SW	SW1	Gewicht (g)
5054 6/4	6/4	5	3	17	15	44	20,5	14	12	36
5054 8/6	8/6	5	5	17	15	44	20,5	14	14	38
5084 8/6	8/6	7	5	25	15	54,5	34,5	22	14	99
5084 10/8	10/8	7	6,5	25	16,5	56	34,5	22	16	103

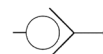

Kupplungsdose Mod. 5055 Mini

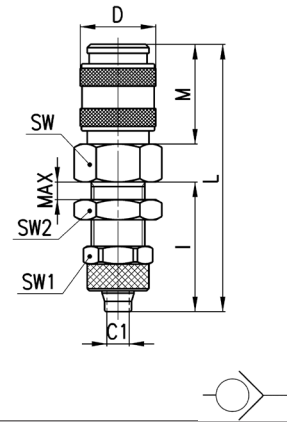

PRODUKTÜBERSICHT												
Mod.	Schlauch	∅	C1	D	I	L	M	Max	SW	SW1	SW2	Gewicht (g)
5055 6/4	6/4	5	3	17	29	58	20.5	10	14	12	14	44
5055 8/6	8/6	5	5	17	29	58	20.5	11	17	14	17	52

Kupplungsdose Mod. 5056 Mini und Mod. 5086 EU Standard



Maß "N" bezieht sich auf den Schlauchinnendurchmesser

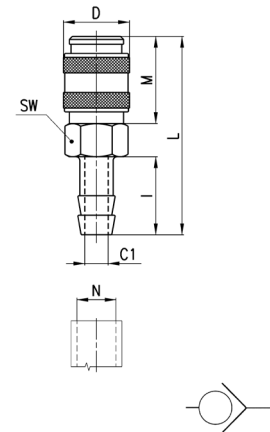

PRODUKTÜBERSICHT										
Mod.	N	∅	C1	D	I	L	M	SW	Gewicht (g)	
5056 06	6	5	3	17	20	49	20.5	14	30	
5056 09	9	5	5	17	20	49	20.5	14	32	
5086 09	9	7	5	25	20	59,5	34,5	22	95	
5086 12	12	7	8	25	20	59,5	34,5	22	96	

Kupplungsdose Mod. 5057 Mini und Mod. 5087 EU Standard

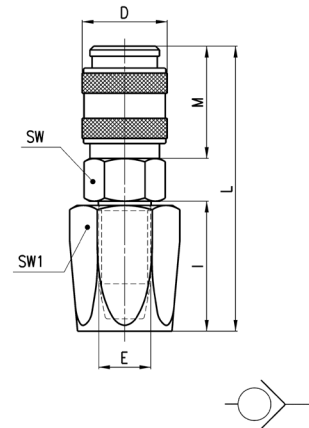

PRODUKTÜBERSICHT										
Mod.	Schlauch	∅	E	D	I	L	M	SW	SW1	Gewicht (g)
5057 6x14	6 x 14	5	9	17	25	54,5	20,5	17	17	62
5087 6x14	6 x 14	7	9	25	25	64,5	34,5	22	17	117
5087 8x17	8 x 17	7	10	25	25	64,5	34,5	22	19	123
5087 10x19	10 x 19	7	12	25	27	66,5	34,5	22	22	141
5087 13x23	13 x 23	7	15	25	37	76,5	34,5	22	27	195

Kupplungsdose Mod. 5058 Mini und Mod. 5088 EU Standard

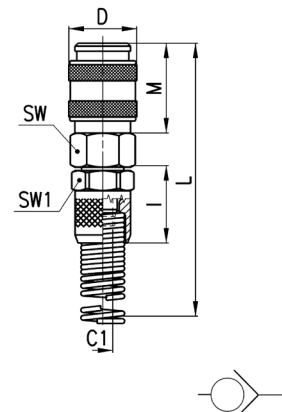

PRODUKTÜBERSICHT										
Mod.	Schlauch	∅	C1	D	I	M	L	SW	SW1	Gewicht (g)
5058 6/4	6/4	5	3	17	19	20.5	120.5	14	14	48
5058 8/6	8/6	5	5	17	19	20.5	124.5	14	14	54
5088 8/6	8/6	7	5	25	19	34,5	135	22	14	118
5088 10/8	10/8	7	6,5	25	21,5	34,5	139,5	22	16	125

Kupplungsstecker Mod. 5150 Mini und Mod. 5180 EU Standard



Zylindrisch

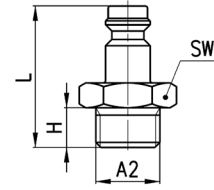

PRODUKTÜBERSICHT						
Mod.	A2	∅	H	L	SW	Gewicht (g)
5150 1/8	G1/8	5	6	26	13	12
5150 1/4	G1/4	5	8	28,5	17	19
5180 1/4	G1/4	7	8	33	17	21
5180 3/8	G3/8	7	9	34	19	26
5180 1/2	G1/2	7	10	35,5	24	34

Kupplungsstecker Mod. 5350 Mini und Mod. 5380 EU Standard



Zylindrisch

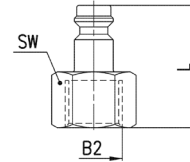

PRODUKTÜBERSICHT					
Mod.	B2	∅	L	SW	Gewicht (g)
5350 1/8	G1/8	5	25,5	13	14
5350 1/4	G1/4	5	27,5	17	18
5380 1/4	G1/4	7	31,5	17	21
5380 3/8	G3/8	7	32,5	19	23
5380 1/2	G1/2	7	36,5	24	37

Kupplungsstecker Mod. 5450 Mini und Mod. 5480 EU Standard

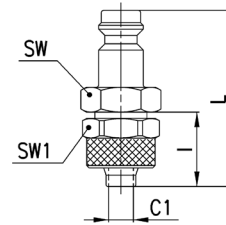

PRODUKTÜBERSICHT								
Mod.	Schlauch	∅	C1	l	L	SW	SW1	Gewicht (g)
5450 6/4	6/4	5	3	15	35	12	12	17
5450 8/6	8/6	5	5	15	35	13	14	22
5480 8/6	8/6	7	5	15	39,5	14	14	25
5480 10/8	10/8	7	6,5	16,5	41,5	17	16	33

Kupplungsstecker Mod. 5650 Mini und Mod. 5680 EU Standard



Maß "N" bezieht sich auf den Schlauchinnendurchmesser

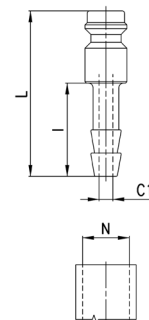

PRODUKTÜBERSICHT						
Mod.	N	∅	C1	l	L	Gewicht (g)
5650 06	6	5	3	20	35,5	8
5650 09	9	5	5	20	35,5	11
5680 06	6	7	3	20	40	14
5680 09	9	7	5	20	40	15
5680 12	12	7	7	20	40	19

Kupplungsstecker Mod. 5750 Mini und Mod. 5780 EU Standard

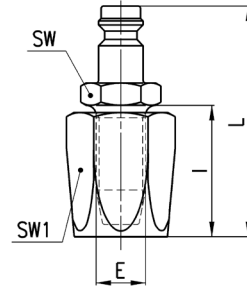

PRODUKTÜBERSICHT								
Mod.	Schlauch	∅	E	I	L	SW	SW1	Gewicht (g)
5750 6x14	6 X 14	5	9	25	45	14	17	40
5780 6x14	6 X 14	7	9	25	50	14	17	44
5780 8x17	8 X 17	7	10	25	50	14	19	50
5780 13x23	13 X 23	7	15	37	62	19	27	123

Kupplungsstecker Mod. 5850 Mini und Mod. 5880 EU Standard

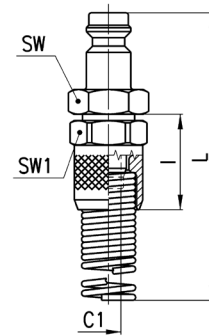

PRODUKTÜBERSICHT								
Mod.	Schlauch	∅	C1	I	L	SW	SW1	Gewicht (g)
5850 6/4	6/4	5	3	19	111,5	12	12	27
5850 8/6	8/6	5	5	19	116	14	14	40
5880 8/6	8/6	7	5	19	120	14	14	44
5880 10/8	10/8	7	6,5	21,5	125	17	16	55

Einhandkupplungen für Heizkreisläufe von Gussformen Serie 5000 L und 5000 LT

Mit/ohne Absperrfunktion, \varnothing 5 und 7 mm
Anschlüsse: G1/8", G1/4", G3/8"



Die Einhandkupplungen Serie 5000 L und 5000 LT wurden entwickelt, um Schläuche für Wasser, Luft oder Öl, die für den Kühlkreislauf von Spritz- und Druckgussformen benötigt werden, zu verbinden.

Die Einhandkupplungen der Serie 5000 L und 5000 LT bieten ein schnelles Verbinden und Lösen von Erhitzungs- und Kühlungsleitungen direkt an der Gussform oder an der Bezugsquelle des Temperiersystems.

- » Einhandkupplung Serie 5000 L: mit Absperrfunktion
- » Einhandkupplung Serie 5000 LT: ohne Absperrfunktion

ALLGEMEINE KENNGRÖSSEN

Nennweite	\varnothing 5, 7 mm
Bauart	Sitzventil mit Stecknippel
Funktion	Kupplung mit/ohne Absperrfunktion
Befestigungsart	Gewinde
Gewinde	G zylindrisch ISO 228 (BSP), andere auf Anfrage
Anschlüsse	G1/8", G1/4", G3/8"
Betriebstemperatur	-15°C ÷ 140°C (200°C bei Öl)
Nominaldruck	6 bar
Betriebsdruck	-0,99 ÷ 12 bar
Durchfluss	Siehe Diagramm
Medium	Druckluft, Wasser und Öl (andere Medien auf Anfrage)
Werkstoffe	Körper Messing, Kugel/Feder Edelstahl, O-Ring FKM

Kupplungen mit Absperrfunktion - Funktionsprinzip und Durchflussdiagramm

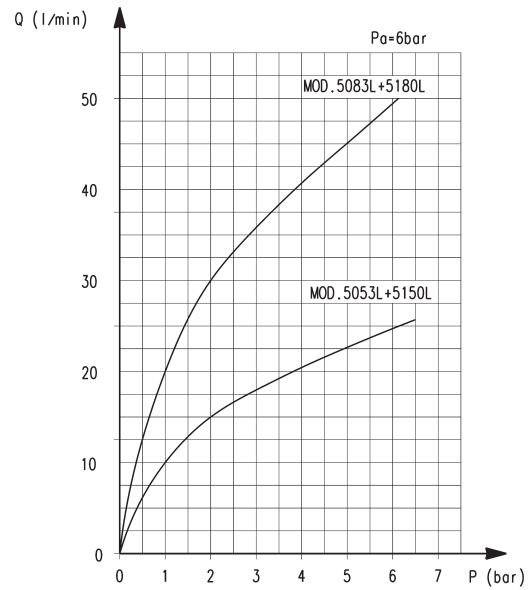
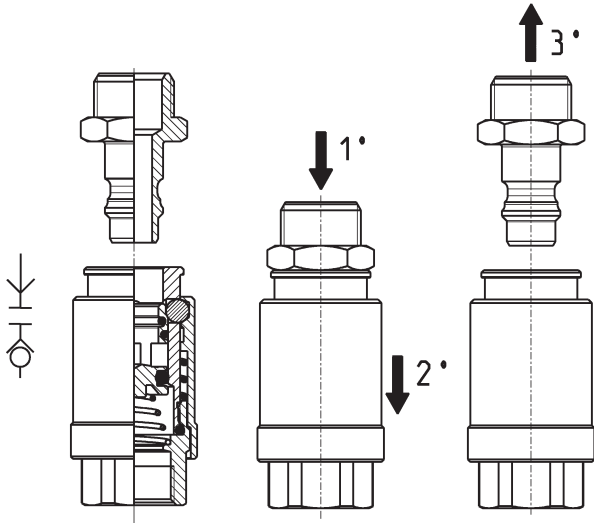

Die Einhandkupplungen verhindern jegliche Leckage während dem Verbinden und Lösen des Stecknippels.

$Q \text{ (l/min)} = \text{Durchfluss} / p = \text{Druckabfall}$

Dieses Diagramm bietet die Möglichkeit zur Auswahl des geeigneten Modells, in Bezug auf Arbeitsdruck und erforderliche Durchflussmenge. Die Messungen wurden mit Wasser bei idealen Durchflussbedingungen durchgeführt. Bei der Verwendung minderwertiger Rohre muss eine schlechtere Performance berücksichtigt werden.

Kupplungen ohne Absperrfunktion - Funktionsprinzip und Durchflussdiagramm

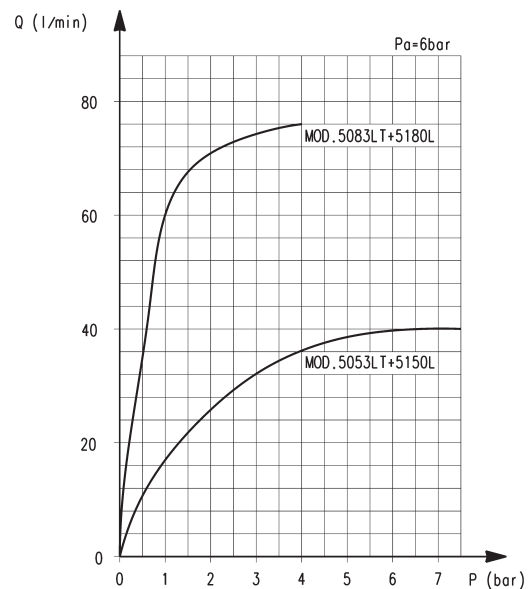
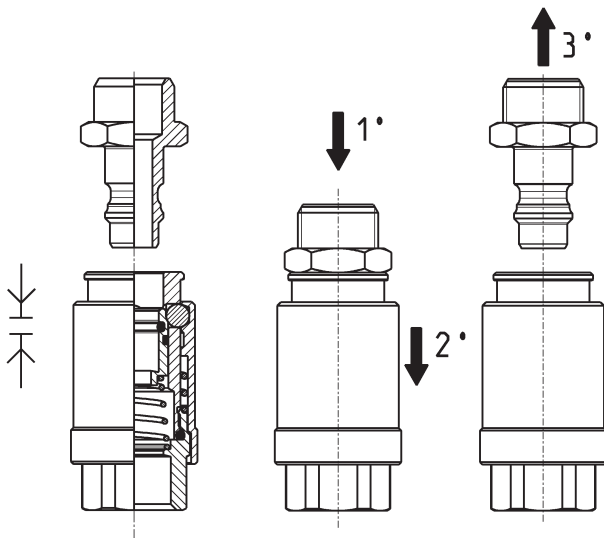

Für Anwendungen, bei denen ein höherer Durchfluss notwendig ist, gibt es die Einhandkupplungen mit Durchgangsbohrung. Diese Lösung bietet einen höheren Durchfluss, verfügt jedoch über keine Absperrfunktion.

$Q \text{ (l/min)} = \text{Durchfluss} / p = \text{Druckabfall}$

Dieses Diagramm bietet die Möglichkeit zur Auswahl des geeigneten Modells, in Bezug auf Arbeitsdruck und erforderliche Durchflussmenge. Die Messungen wurden mit Wasser bei idealen Durchflussbedingungen durchgeführt. Bei der Verwendung minderwertiger Rohre muss eine schlechtere Performance berücksichtigt werden.

Kupplungsdose Mod. 5053L und 5053 LT



Zylindrisch

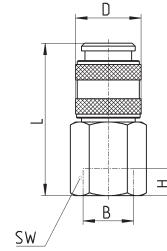

PRODUKTÜBERSICHT							
Mod.	B	D	H min	L	SW	Gewicht (g)	Schaltzeichen
5053L 1/8	G1/8	17	6	37	14	34	VNR3
5053L 1/4	G1/4	17	7	39	17	44	VNR3
5053LT 1/8	G1/8	17	6	37	14	34	VNR2
5053LT 1/4	G1/4	17	7	39	17	44	VNR2



Kupplungsdose Mod. 5083L und 5083 LT



Zylindrisch

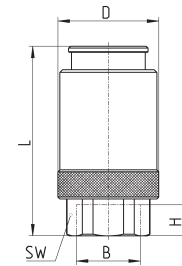

PRODUKTÜBERSICHT							
Mod.	B	D	H min	L	SW	Gewicht (g)	Schaltzeichen
5083L 1/4	G1/4	26	10	47.5	17	104	VNR3
5083L 3/8	G3/8	26	8	49	20	110	VNR3
5083LT 1/4	G1/4	26	10	47.5	17	104	VNR2
5083LT 3/8	G3/8	26	8	49	20	110	VNR2



Kupplungsstecker Mod. 5150 L und 5180 L



Zylindrisch

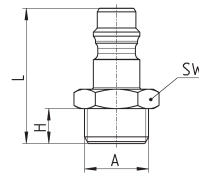

PRODUKTÜBERSICHT					
Mod.	A	H	L	SW	Gewicht (g)
5150L 1/8	G1/8	6	26.5	13	11
5150L 1/4	G1/4	8	29	17	17
5180L 1/4	G1/4	8	34	17	21
5180L 3/8	G3/8	9	35	19	25



Schläuche, Schlauchspiralen und Zubehör

Schläuche: PVC gewebeummantelt, Polyamid PA 12, Polyamid Superflexibel, Polyethylen, Polyurethan, Thermoplastisches Elastomer auf Polyesterbasis. Ø: 3/1,7, 4/2, 5/3, 6/4, 8/6, 10/8, 12/9, 12/10, 14/11, 15/12, 15/12,5, 16/13 mm



Camozzi bietet eine große Auswahl an Schläuchen, Schlauchspiralen und Zubehör mit spezifischen Eigenschaften und sind dadurch für verschiedene technische Anforderungen geeignet. Dank hochwertiger Rohstoffe mit geringem Gewicht zeichnen sie sich vor allem durch eine hohe Resistenz gegen Beanspruchung und Biegeschwingungen aus.

Die besonders glatte Oberfläche (Rautiefe ca. 6 µm) im Inneren des Schlauches verhindert eine hohe Reibung und ermöglicht einen hohen Durchfluss. Die eingesetzten Kunststoffe sind sehr alterungsbeständig und gewährleisten so eine sehr lange Produktlebensdauer.

Schlauch Mod. PV - Bitte beachten, dass der Bereich Schläuche /



PRODUKTÜBERSICHT					
Mod.	D/d				
PV 6/4	6/4	40	22	50	50
PV 8/6	8/6	38	30	60	50
PV 10/8	10/8	30	40	65	50
PV 12/10	12/10	24	56	80	50
PV 15/12,5	15/12.5	18	70	90	50

Schlauch Mod. TRN - Bitte beachten, daß der Bereich Schläuche /



PRODUKTÜBERSICHT					
Mod.	D/d	Betriebsdruck 23°C (bar)	Gewicht g/m	Biegeradius (mm)	Rollenlänge (m)
TRN 4/2	4/2	44	9.7	16	100
TRN 5/3	5/3	33	12.9	20	100
TRN 6/4	6/4	28	16.2	30	100
TRN 8/6	8/6	20	22.6	40	100
TRN 10/8	10/8	16	29.1	60	50
TRN 12/10	12/10	12	35.6	85	50



PRODUKTÜBERSICHT					
Mod.	D/d	Betriebsdruck 23°C (bar)	Gewicht g/m	Biegeradius min (mm)	Rollenlänge (m)
TRH 4/2-Z	4/2	32	11.5	16	100
TRH 5/3-Z	5/3	27	15.3	25	100
TRH 6/4-Z	6/4	21	19.2	35	100
TRH 8/6-Z	8/6	15	26.8	65	100
TRH 10/8-Z	10/8	12	34.5	100	50
TRH 12/10-Z	12/10	10	42.1	125	50

Schlauch Mod. TPE - Bitte beachten, dass der Bereich Schläuche /



PRODUKTÜBERSICHT					
Mod.	D/d				
TPE 5/3	5/3	17	11.3	23	100
TPE 6/4	6/4	13	14.1	32	100
TPE 8/6	8/6	10	19.8	43	100
TPE 10/8	10/8	7	25.4	76	100

Schlauch Mod. TPC - Bitte beachten, dass der Bereich Schläuche /



PRODUKTÜBERSICHT					
Mod.	D/d				
TPC 4/2	4/2	19	11.5	11	100
TPC 6/4	6/4	13	19.2	18	100
TPC 8/6	8/6	9	26.8	35	100
TPC 10/8	10/8	7	34.5	45	100
TPC 12/8	12/8	9	76.6	50	100

Schlauchspirale Mod. TSP - Bitte beachten, daß der Bereich Schläuche /



PRODUKTÜBERSICHT					
Mod.	D/d				
TSP 6/4	6/4	20	64	1000	15000
TSP 8/6	8/6	14	86	1000	15000
TSP 10/8	10/8	11	102	1050	15000
TSP 12/10	12/10	9	126	1050	15000

Schlauchklemme Mod. MPL - Bitte beachten, daß der Bereich Schläuche /

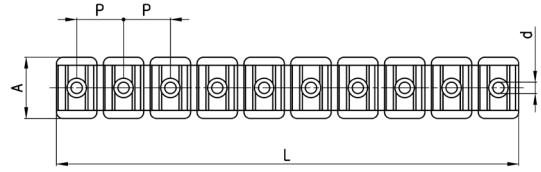

Mod.	Schlauch Ø (mm)	L	A	d	P
MPL-4	4	114	19	2.8	11.7
MPL-6	6	114	19	2.8	11.7
MPL-8	8	143	19	3.8	14.6
MPL-10	10	172	19	5.3	17.4
MPL-12	12	162	19	5.3	20.5
MPL-14	14	180	19	5.3	22.5

Schlauchschneider Mod. PNZ... + PNZP-12

PNZ-12 bis Schlauchdurchmesser 12 mm
 PNZ-25 bis Schlauchdurchmesser 25 mm
 Ersatzklingen können separat bestellt werden.

Kunststoff-Schlauchschneider Mod. PNZP-12: für
 Schläuche bis Durchmesser 12 mm.



PNZ-...



PNZP-12

PRODUKTÜBERSICHT	
Mod.	
PNZ-12	bis Durchmesser 12 mm
PNZ-25	bis Durchmesser 25 mm
PNZP-12	bis Durchmesser 12 mm

Nutwerkzeug für Metallrohre Mod. 8TRT

Neu

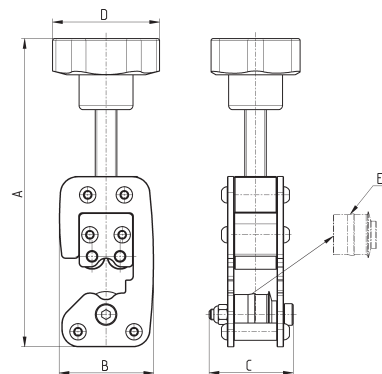

PRODUKTÜBERSICHT							
Mod.	Schlauch Ø	A (max)	B	C	D	Gewicht (g)	E
8TRT 4	4	138	43.5	39	50	450	RTRT 4
8TRT 6	6	140	43.5	39	50	450	RTRT 6
8TRT 8	8	143	44	39	50	450	RTRT 8
8TRT 10	10	145	44	39	50	450	RTRT 10
8TRT 12	12	147	44.5	39	50	450	RTRT 12
8TRT 14	14	149	45	39	50	450	RTRT 14
8TRT 16	16	151	45	39	50	450	RTRT 16

Steckverschraubungen und Zubehör für Anwendungen mit medizinischen Gasen

Durchmesser: \varnothing 4, 6, 8 mm

Anschlüsse: M5, G1/8", G1/4", R1/8", R1/4"



Die sauerstoffgeeigneten Verschraubungen OX1 wurden für den Bereich Life Science konzipiert, insbesondere für medizinische und analytische Anwendungen. Gerätehersteller von Beatmungsgeräten, Anästhesiegeräten, Sauerstoffkonzentratoren, Massenspektrometrie oder biomedizinischen Analysegeräten haben die Verschraubungen OX1 sowie deren Zubehör seit vielen Jahren qualifiziert.

Reinigungsklasse OX1: Nichtflüchtige Rückstände nicht mehr als 550 mg/m²
Level OX1: ultraschallgereinigt, mit UV-Licht geprüft, Schmierung mit einem für Sauerstoff geeigneten spezifischen Fett

- » Ultraschallreinigung
- » sauerstoffgeeignete Schmierung
- » bewährte Spannzangen-Technologie
- » Langlebigkeit
- » geeignet für Schläuche aus PA, PU, PE, Fluorpolymer

Serie 6000 OX1 Steckverschraubungen Superrapid:

Die Spannzange der Steckverschraubungen Superrapid Serie 6000 OX1 wurde mit den Anforderungen entwickelt, eine homogene Dichtigkeit auf der gesamten Oberfläche von Kunststoffschläuchen zu gewährleisten. Diese Eigenschaft garantiert eine hohe Zuverlässigkeit und lange Lebensdauer, auch nach mehrmaliger Montage und Demontage des Schlauchs.

Serie VNR OX1 Rückschlagventile:

Die Rückschlagventile Serie VNR OX1 sind mit integrierten Steckanschlüssen ausgestattet und eignen sich daher besonders für den direkten Leitungseinbau. Ihre Bauweise ermöglicht auch den Einsatz im Niederdruckbereich.

Serie 2000 OX1 Verschraubungszubehör für Messingrohre:

Das breite Sortiment dieser Serie beinhaltet u.a. Winkelstücke, T-Anschlüsse, Doppelnippel und gewährleistet die notwendigen Kombinationsmöglichkeiten bei der Konzipierung von medizinischen und analytischen Systemen.

ALLGEMEINE KENNGRÖSSEN

Serie 6000

Durchmesser	∅ 4, 6, 8 mm
Gewinde	GAS zylindrisch ISO 228 (BSP); M5
Betriebstemperatur	-15 °C ÷ 80 °C (siehe technische Daten des eingesetzten Schlauchs)
Werkstoffe Schlauch	Polyamid (PA) 6 - 11 - 12, Polyurethan (PU), Fluorpolymer (FEP)
Medium	Sauerstoff, Medizinische Gase, Druckluft oder andere Niederdruckfluide
Werkstoffe	Körper und Spannzanze Messing vernickelt, O-Ring FKM mit sauerstoffgeeigneter Schmierung
Betriebsdruck	-0,9 bar ÷ 16 bar (siehe Schlauch)

Serie VNR

Funktion	Rückschlagventil
Bauart	Sitzventil
Werkstoffe	Körper Messing Feder Edelstahl Dichtungen FKM
Einbaulage	Beliebig
Durchmesser	∅ 4, 6, 8 mm
Betriebstemperatur	0 °C ÷ 80 °C
Medium	Sauerstoff, Medizinische Gase, Druckluft oder andere Niederdruckfluide

Serie 2000

Gewinde	GAS konisch ISO 7 (BSPT) GAS zylindrisch ISO 228 (BSP)
Betriebstemperatur	-40 °C ÷ 120 °C
Medium	Sauerstoff, Medizinische Gase, Druckluft oder andere Niederdruckfluide
Werkstoffe	Messing vernickelt
Betriebsdruck	80 bar

STECKVERSCHRAUBUNGEN UND ZUBEHÖR FÜR ANWENDUNGEN MIT MEDIZINISCHEN GASEN

Gerade Einschraub-Verschraubungen Mod. 6512-OX1

Neu

Mit O-Ring montiert, zylindrisch

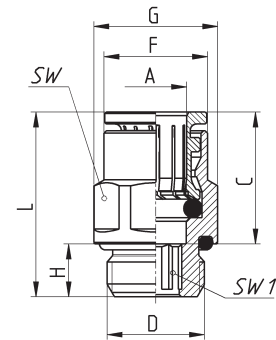

PRODUKTÜBERSICHT										
Mod.	A	D	C	F	G	H	L	SW	SW1	Gewicht (g)
6512 4-M5-OX1	4	M5	14.0	7.8	8.8	4	20	8	2	4
6512 4-1/8-OX1	4	G1/8	14.0	8.8	13.5	6	19	12	2.5	10
6512 6-M5-OX1	6	M5	16.0	11.7	13.2	4	22	12	2	8
6512 6-1/8-OX1	6	G1/8	16.0	11.7	13.5	6	21	12	4	10
6512 6-1/4-OX1	6	G1/4	16.0	11.7	16.4	7	22	15	4	13
6512 8-1/8-OX1	8	G1/8	17.5	13.7	15.2	6	26	14	5	15
6512 8-1/4-OX1	8	G1/4	17.5	13.7	16.4	7	24.5	15	6	17

Einpress-Patrone Mod. 6700-OX1

Neu

S* = Bohrungsgeometrie Metall/
Kunststoff
siehe Einbaugeometrie rechts

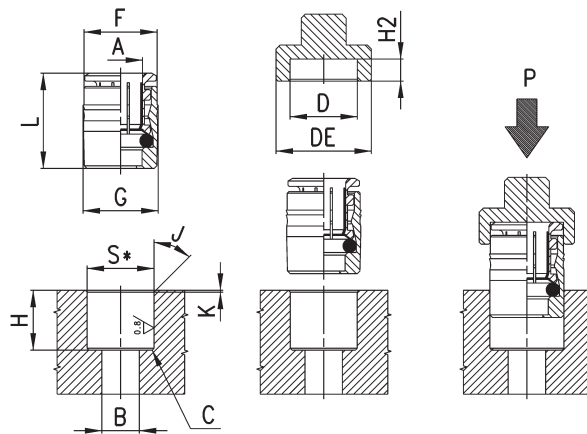

PRODUKTÜBERSICHT																
Mod.	A	B	C	D	DE	F	G	H	H2 (+0,1/0)	J	K	L	P min (Kg)	P max (Kg)	S (+0,01/-0,04)	Gewicht (g)
6700 4-OX1	4	3.5	0.5x45°	8.8	14	8.6	9	11	3.3	15°	0.5	14.5	200	360	8.75	4
6700 6-OX1	6	4	0.5x45°	12	17	11.8	12.2	12	3.8	15°	0.5	16.5	160	570	11.95	8

Gerade Aufschraub-Verschraubung Mod. 6463-OX1

Neu

Zylindrisch

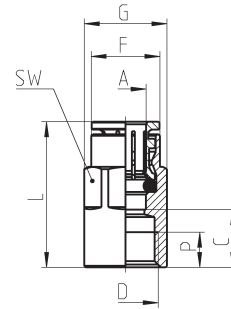

PRODUKTÜBERSICHT									
Mod.	A	D	C	F	G	L	P (min)	SW	Gewicht (g)
6463 4-1/8-OX1	4	G1/8	10	9	13	24	6	12	14
6463 6-1/8-OX1	6	G1/8	10	11.7	13	26	6	12	14
6463 6-1/4-OX1	6	G1/4	11.5	11.9	16.5	27.5	7	15	23

Winkel-Einschraub-Verschraubung Mod. 6522-OX1

Neu

Mit O-Ring montiert, zylindrisch, drehbar

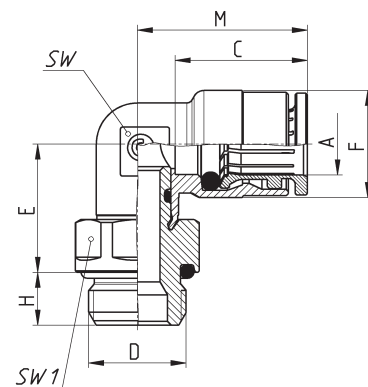

PRODUKTÜBERSICHT										
Mod.	A	D	C	E	F	H	M	SW	SW1	Gewicht (g)
6522 4-M5-OX1	4	M5	14.0	12.5	9	4	17.5	8	8	12
6522 4-1/8-OX1	4	G1/8	14.0	14.5	9	6	17.5	8	12	15
6522 6-M5-OX1	6	M5	16.0	13	12.7	4	20	9	10	14
6522 6-1/8-OX1	6	G1/8	16.0	15	12.7	6	20	9	12	19
6522 6-1/4-OX1	6	G1/4	16.0	16	12.7	7	20	9	15	27
6522 8-1/8-OX1	8	G1/8	17.5	16	14.2	6	22.5	11	12	22
6522 8-1/4-OX1	8	G1/4	17.5	17	14.2	7	22.5	11	15	28

Gerade Schottverschraubung Mod. 6590-OX1

Neu

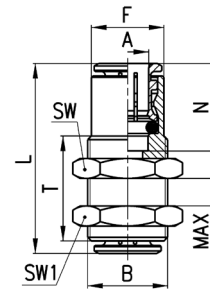

PRODUKTÜBERSICHT										
Mod.	A	B	F	L	N	MAX	SW	SW1	T	Gewicht (g)
6590 4-OX1	4	M10x1	8.8	29	14	10.5	14	14	20	16
6590 6-OX1	6	M14x1	12.5	33	16	10.5	17	17	20	28

Gerader Verbinder Mod. 6580-OX1

Neu



Für Schottmontage Seegerringe UNI 7434 und DIN 6799 verwenden

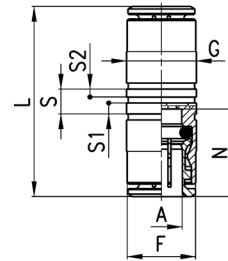

PRODUKTÜBERSICHT									
Mod.	A	F	G	L	N	S	S1	S2	Gewicht (g)
6580 4-OX1	4	8.4	9	29	14	5	2.2	1.6	11
6580 6-OX1	6	11.7	12	34	16	5	2.2	1.6	16
6580 8-OX1	8	13.7	14	37	17.5	5	2.2	1.6	23

Winkel-Anschluss Mod. 6550-OX1

Neu

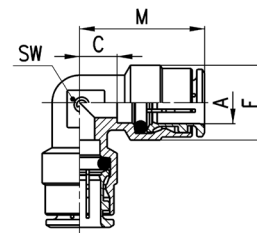

PRODUKTÜBERSICHT						
Mod.	A	C	F	M	SW	Gewicht (g)
6550 4-OX1	4	3.5	9	17.5	8	8
6550 6-OX1	6	4	12.7	20	9	17

T-Anschluss Mod. 6540-OX1

Neu

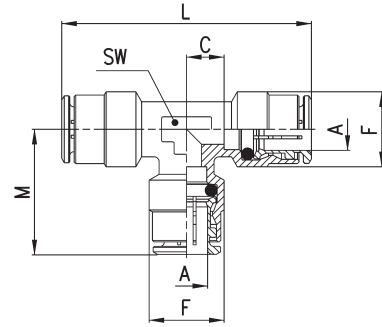

PRODUKTÜBERSICHT							
Mod.	A	C	F	L	M	SW	Gewicht (g)
6540 4-OX1	4	3.5	9	35	17.5	8	14
6540 6-OX1	6	4	12.7	40	20	9	24

Y-Anschluss Mod. 6560-OX1

Neu

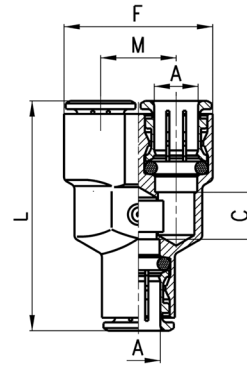

PRODUKTÜBERSICHT						
Mod.	A	C	F	L	M	Gewicht (g)
6560 4-OX1	4	5	18	33	9	19
6560 6-OX1	6	7	24.5	39	12.5	30

Verschluss-Stück Mod. 6750-OX1

Neu

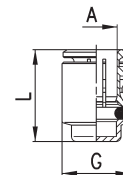

PRODUKTÜBERSICHT				
Mod.	A	G	L	Gewicht (g)
6750 4-OX1	4	8.8	15	4
6750 6-OX1	6	11.8	17	7

Reduzierung Mod. 6800-OX1

Neu

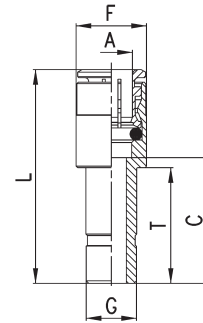

PRODUKTÜBERSICHT							
Mod.	A	G	C	F	L	T	Gewicht (g)
6800 4-6-OX1	4	6	15.5	9	29.5	18	9
6800 4-8-OX1	4	8	18	9	32	20.5	10
6800 6-8-OX1	6	8	18	12.7	34	20.5	12

Winkelsteckanschluss Mod. 6555-OX1

Neu

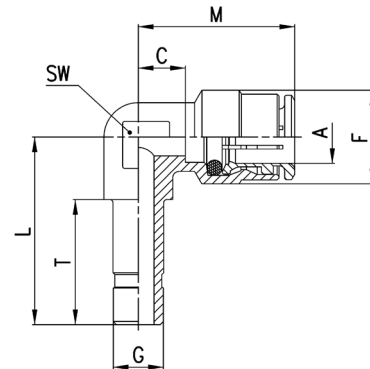

PRODUKTÜBERSICHT									
Mod.	A	G	C	L	F	T	M	SW	Gewicht (g)
6555 6-6-OX1	6	6	4	24.5	12.7	18	20	9	14

Verschluss-Stecker Mod. 6900-OX1

Neu



Werkstoff: Kunststoff/Polyamid

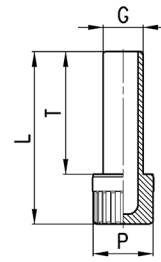

PRODUKTÜBERSICHT					
Mod.	G	L	P	T	Gewicht (g)
6900 4-OX1	4	29	8	20	1
6900 6-OX1	6	31.5	8	22.5	1

Rückschlagventile Serie VNR

Neu

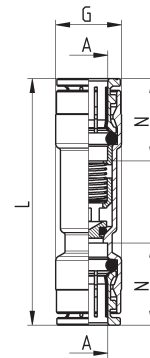

PRODUKTÜBERSICHT								
Mod.	A	G	L	N	Durchfluss bei 6 bar ΔP1 (NL/min)	Min. Betriebsdruck (bar)	Max. Betriebsdruck (bar)	Gewicht (g)
6580 4-VNR-OX1	4	9	40	14	85	0,2	10	13
6580 6-VNR-OX1	6	12	48	16	450	0,2	10	20
6580 8-VNR-OX1	8	14	52.5	17.5	900	0,2	10	30



Doppelnippel Mod. 2500-OX1

Neu



Konisch

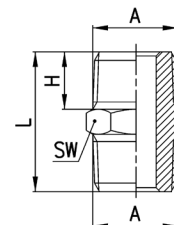

PRODUKTÜBERSICHT					
Mod.	A	H	L	SW	Gewicht (g)
2500 1/8-OX1	R1/8	7,5	19,5	12	9
2500 1/4-OX1	R1/4	11	27	14	16

Doppelnippel Mod. 2501-OX1

Neu

Zylindrisch

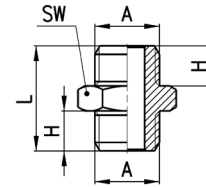

PRODUKTÜBERSICHT					
Mod.	A	H	L	SW	Gewicht (g)
2501 1/8-OX1	G1/8	6	16,5	13	9
2501 1/4-OX1	G1/4	8	21	17	15

Doppel-Reduziernippel Mod. 2510-OX1

Neu

Konisch

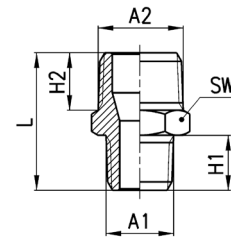

PRODUKTÜBERSICHT							
Mod.	A1	A2	H2	H1	L	SW	Gewicht (g)
2510 1/8-1/4-OX1	R1/8	R1/4	11	7,5	23,5	14	14

Reduziernippel Mod. 2531-OX1

Neu

Zylindrisch

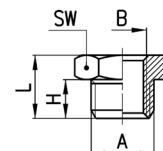

PRODUKTÜBERSICHT						
Mod.	A	B	H	L	SW	Gewicht (g)
2531 1/8-M5-OX1	G1/8	M5	6	10,5	13	8 *
2531 1/4-1/8-OX1	G1/4	G1/8	8	13	17	11 *

* = durchgehendes Innengewinde

Muffe Mod. 2543-OX1

Neu

Zylindrisch

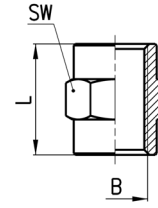

PRODUKTÜBERSICHT					
Mod.	B	L	SW	Gewicht (g)	
2543 M5-OX1	M5	11	8	3	
2543 1/8-OX1	G1/8	15	13	8	
2543 1/4-OX1	G1/4	22	17	19	

Verschluss-Schraube Mod. 2611-OX1

Neu

Zylindrisch

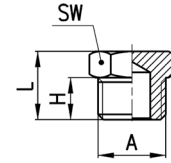

PRODUKTÜBERSICHT					
Mod.	A	H	L	SW	Gewicht (g)
2611 M5-OX1	M5	4	7,5	8	2
2611 1/8-OX1	G1/8	6	10,5	13	7
2611 1/4-OX1	G1/4	8	13	17	13

STECKVERSCHRAUBUNGEN UND ZUBEHÖR FÜR ANWENDUNGEN MIT MEDIZINISCHEN GASEN

Winkelstück Mod. 2013-OX1

Neu

Zylindrisch

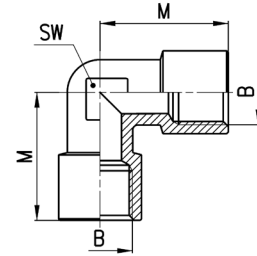

PRODUKTÜBERSICHT				
Mod.	B	M	SW	Gewicht (g)
2013 1/8-OX1	G1/8	19	11	16
2013 1/4-OX1	G1/4	23	14	28

Winkelstück Mod. 2021-OX1, Mod. 2020-OX1

Neu

Konisch/zylindrisch

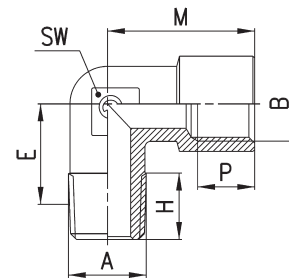

PRODUKTÜBERSICHT								
Mod.	A	B	E	H	M	P (min)	SW	Gewicht (g)
2020 1/8-1/8-OX1	R1/8	G1/8	11,5	8,5	19	6	11	17
2020 1/4-1/4-OX1	R1/4	G1/4	15	11	23	7	13	27

STECKVERSCHRAUBUNGEN UND ZUBEHÖR FÜR ANWENDUNGEN MIT MEDIZINISCHEN GASEN

T-Anschluss Mod. 2003-OX1

Neu

Zylindrisch

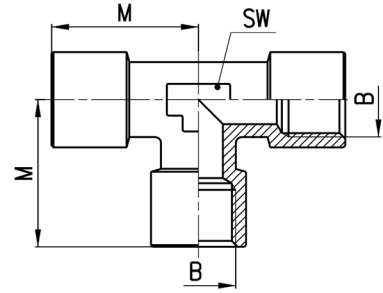

PRODUKTÜBERSICHT				
Mod.	B	M	SW	Gewicht (g)
2003 1/8-OX1	G1/8	19	12	23
2003 1/4-OX1	G1/4	23	13	39

Y-Stück Mod. 2043-OX1

Neu

Zylindrisch

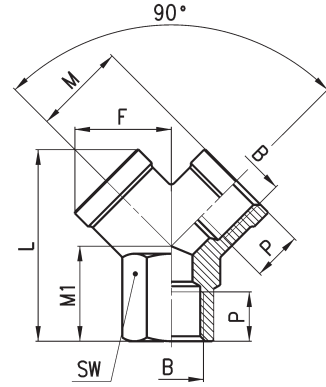

PRODUKTÜBERSICHT								
Mod.	B	F	L	M	M1	P	SW	Gewicht (g)
2043 1/8-OX1	G1/8	14,5	26,5	14	12	8	13	18
2043 1/4-OX1	G1/4	18	32	17,5	14	11	17	32

STECKVERSCHRAUBUNGEN UND ZUBEHÖR FÜR ANWENDUNGEN MIT MEDIZINISCHEN GASEN

Kontakt



Camozzi Automation GmbH

Porschestraße 1
D-73095 Albershausen
Tel. +49 7161 91010-0
info@camozzi.de
www.camozzi.de



Camozzi Automation GmbH

Löfflerweg 18
A-6060 Hall in Tirol
Tel. +43 5223 52888-0
info@camozzi.at
www.camozzi.at



Automation

