

SHUTON



IPIRANGA

ROLLON[®]

BY TIMKEN



XL

Xtrem
Load

SHUTON-IPIRANGA has verified the accuracy of all the data contained in this catalogue. However, it does not accept liability for any possible incorrect or incomplete data.

Due to the constant development of products, SHUTON-IPIRANGA reserves the right to modify any information or data in this catalogue without notice.

Publisher:

SHUTON S.A.U.

Polígono Industrial Goain

01170 Legutiano (Álava)

SPAIN

www.shuton.com

www.ipirangahusillos.com

e-mail: info@shuton-ipiranga.com

Version EN23

All rights reserved.

Reproduction in full or in part, without SHUTON-IPIRANGA authorisation, is prohibited.



PRECISION BALL SCREWS

This catalogue contains the tables of dimensions, loads and nut rigidities,
according to DIN 69051 and ISO 3408 standards,
of precision ball screws manufactured by SHUTON-IPIRANGA.

INDEX

01

**Company
introduction**

p. 06

02

**Ball screw
technology**

p. 10

2.1 IML, HDL, PKL
Technologies

p. 12

06

**Reference
definition**

p. 24

07

**Ball screws
according
fastening method**

p. 26

03

Customised Solutions

p. 18

04

Engineering Service

p. 20

05

Quick selection of a ball screw

p. 23

08

Tables of load and dimensions

p. 28

2.1 IML, HDL, PKL Technologies

p. 32

09

SHUTON·IPIRANGA location and contacts

p. 142

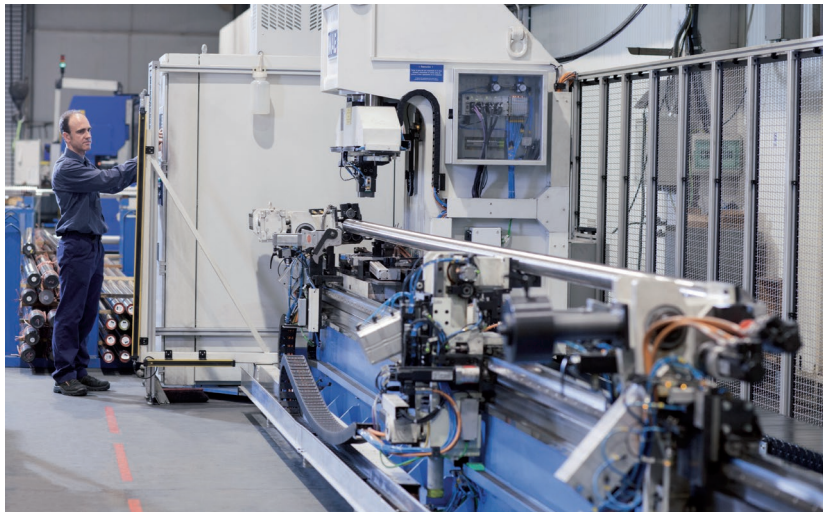
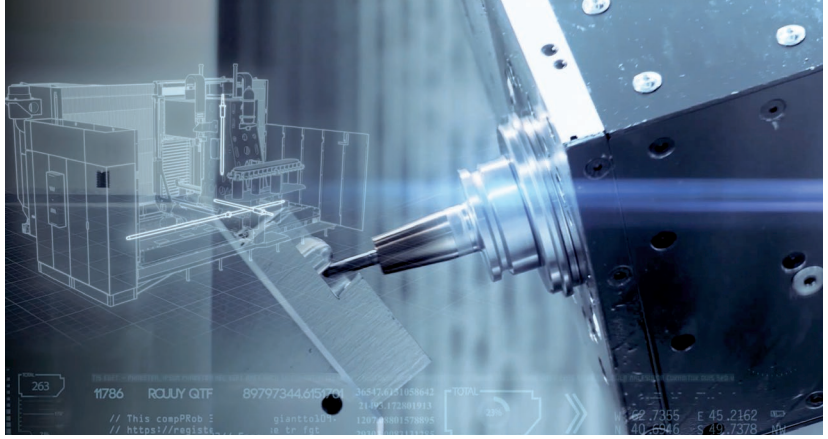

“

***A global and joint project** that allows us to expand our product range with more technologies, group perspective investments and access to more markets.*

”

NEW

challenges strategies

As a result of the evolution of the market and the challenges the new competitive scenarios demand, we are proud to announce the merge of two important players in the ball screw manufacturing sector.

Shuton and Ipiranga, specialized in the design and manufacture of Precision Ball screws and with over 50 years' experience each one, started a path of collaboration in the year 2018 that has resulted in the final merge as presented in this catalogue.

We join forces, multiplying capacities, adding solvencies. A single organization that optimizes resources to be more efficient

This year has also brought us an important milestone, as we become part of the world's leading bearings and power transmission manufacturer The Timken Company.

A global and joint project that allows us to expand our product range with more technologies, group perspective investments and access to more markets.



HIGHER PERFORMANCE

Improvement in ball screw acceleration and feed speeds for a better performance for longer duration in extreme applications.



HIGHER RIGIDITY

Efficient rigidity oriented at enhancing the machining quality of the parts, optimizing the natural frequency of the system and improving motor parameters K_v and K_p , and the jerk.



HIGHER DYNAMICS

Improvement of accelerations and feed speeds of the drive, keeping optimum temperature and noise levels.



Engineered by SHUTON-IPIRANGA



HIGHER DURABILITY

Parallel improvements in materials, treatment and manufacturing processes contribute to an additional increase of the ball screw life.



INCREASED UPTIME

Improvement of ball screw life for increasing the machine uptime.



LESS MAINTENANCE

Improvement of ball screw performance and life for a reduction of life-cycle costing (LCC).

HIGH DYNAMICS INSIDE

Xtrem Dynamics redefines **SHUTON-IPIRANGA**'s philosophy in the search of technologies and materials with the aim of increasing the rigidity of the Ball screws, to improve the dynamics and therefore the efficiency of the machine, resulting in productivity for longer.

In line with this **Xtrem Dynamics** philosophy and with the aim of obtaining the best results in the most demanding applications, **SHUTON-IPIRANGA** has developed different ball screw technologies adapted to the main application areas, classified in three families:



XP

Xtrem
Position



XL

Xtrem
Load



XT

Xtrem
Transport

Ball screw technology

The SHUTON-IPIRANGA ball screw range is the result of internal developments by the R&D&i department. Numerous tests and measurements have been carried out over several years in the technological centre that SHUTON-IPIRANGA has in its premises as well as in collaborations with universities and research and development centres.

SHUTON-IPIRANGA ball screws are manufactured with premium steel and subject to heat treatments of the highest quality.

In order to get the most of the advantages a ball screw can offer, it is necessary to choose the correct ball screw configuration for each application. SHUTON-IPIRANGA offers its customers comprehensive advice for the selection of the most appropriate ball screw and optimal use for each application, studying the different solutions. For more details on Engineering Service, Technical application form and Technical studies, see page 20.

SHUTON-IPIRANGA has developed the following ball screw technologies to give a response to our customers' requirements:

	Features	Sector	Technology	Nut Type
	High loads Efficiency Custom design	<ul style="list-style-type: none"> · Injection machine · Presses · Elevators · Actuators · Boarding bridges · Energy · Hexapods · Seismic dampers · Construction 	IML	TS Single Nut
			HDL	TS Single Nut
			PKL	TS Single Nut

CUSTOMISED SOLUTIONS

Adapted solutions for specific requirements: Asymmetric nut, Ceramic balls, Special wipers, Single nut with Preload, Special nuts, Rotary nut system, Special spindle end machining, Refrigerated shaft, Safety Nut, W spaced balls recirculation system, iBallscrew.

Description page 18.



**HIGH DYNAMIC AND HIGH
LOAD BALL SCREWS FOR
HEAVY DUTY APPLICATIONS.**

SECTORS

Injection machine

Presses

Elevators

Actuators

Boarding bridges

Energy

Hexapods

Seismic dampers

Construction

TECHNOLOGIES

IML, HDL, PKL

High dynamics and high load ball screws for injection molding machines, presses and other heavy duty applications operated by electric servo drive in extreme conditions.

IML, HDL, PKL TECHNOLOGIES

The Loading ball screw family offers high dynamics and high loads for injection molding machines, presses and other heavy duty applications operated by electric servodrives which may reach extreme working condition requirements.

Loading ball screws offer top results with high durability and reliability. The technology of these ball screws contributes towards achieving especially high values of dynamic and static load capacity, as well as high values of maximum permissible loads.

The optimized recirculation system design leads to improved results in several key aspects of the ball screw. A Loading ball screw can be designed with U-type or B-type recirculation system. A U-shaped or a B-shaped deflector smoothly redirects the balls in tangential direction through a recirculating hole along the nut. Then another U-shaped or B-shaped deflector feeds the balls back into the recirculation circuits. These designs include a tangential ball pick-up that minimizes collisions between balls and recirculation system, and a specific 3D curve design to avoid collisions between balls.

U-type recirculation

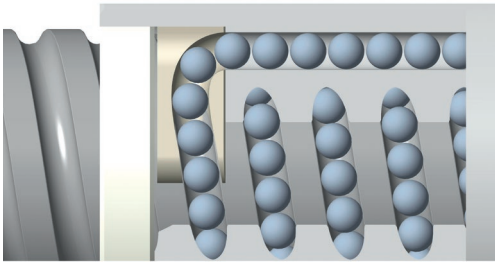

B-type recirculation

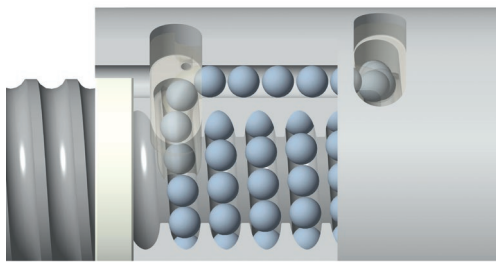

This optimised ball recirculation system guarantees a very smooth rotation as it ensures ball circulation to be uniform and ordered, avoiding any crashes between balls and resulting in very low noise levels and enabling the use of higher feed speed values, thus reaching DN values up to 170.000.

In Loading ball screws, components are subjected to high forces. This fact, accompanied by the high speed achieved by applications like injection moulding machines makes the design and materials of the recirculation systems especially important.

The Loading nut design is based on a single nut distribution, offering a very compact and easy to adapt design for machine applications. The nut is not preloaded and has a slight axial play. This axial play depends on the duty cycle and expected working temperature. A temperature increase, which affects negatively to the correct ball screw performance, is avoided.

Accuracy grade and axial play

- H 0.020 mm or less.
- A 0.040 mm or less.

Loading ball screw technologies

Depending on the application requirement of load capacity and speed, and in order to obtain the optimum life results in each case, SHUTON·IPIRANGA has developed three different Loading ball screw technologies:

Depending on the application's requirement of load capacity and speed, and in order to obtain the optimum life results in each case, SHUTON·IPIRANGA high load ball screws range has been optimized in three types of technology: IML, HDL and PKL, specially adapted to different types of application.

IML HIGH LOAD TECHNOLOGY

- It is designed for high load and high speed applications with DN up to 170.000.
- It is indicated when there is a high load resulting in high average force and at the same time medium and high speeds, resulting in a medium to high average speed.
- IML technology enables working temperature to be kept controlled.

HDL HIGH LOAD TECHNOLOGY

- It is designed for very high load and moderate speed applications with DN up to 110.000.
- It is indicated when there is a high load, resulting in high average force, and at the same time low speeds, resulting in a low average speed.
- It is the option that gives a greatest dynamic, static load and rigidity.

PKL HIGH LOAD TECHNOLOGY

- It is designed for applications with momentary extreme peak loads, where the average force does not have to be particularly high.
- Possibility of high speed, both in peak speed as in average speeds.

In the following graph it is possible to see the comparison in the results of life, peak load and speed, of the different types of HIGH LOAD ball screws:

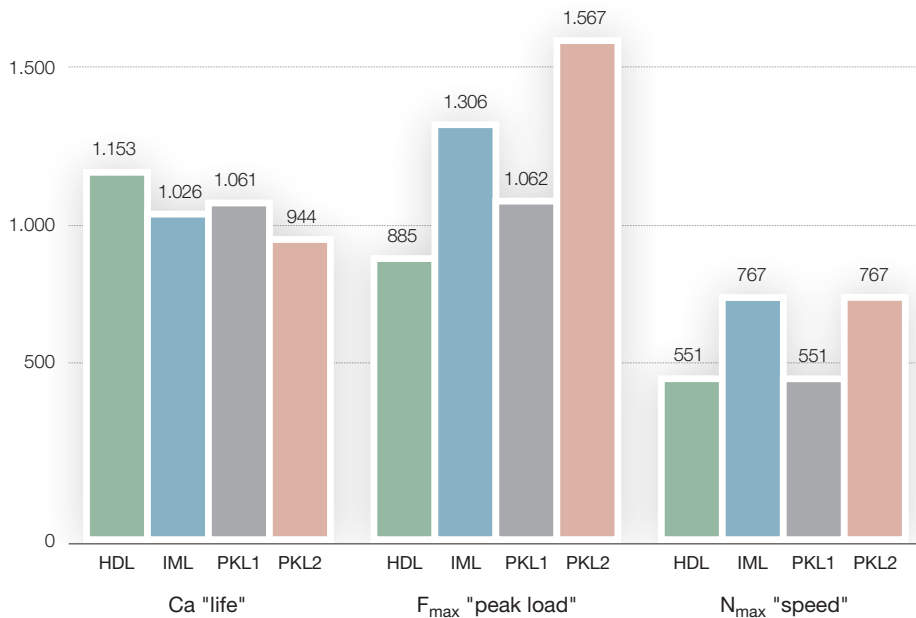

It is very important to design the ball screw according the singularities of each application. Apart from optimum combination of shaft diameter, lead and ball diameter, SHUTON·IPIRANGA Engineering Service studies most appropriate:

- Most suitable loading ball screw technology
- Shaft and nut thread geometry
- Ball circuit distribution and position
- Number of thread starts

Load distribution in Loading ball screws

Also, for taking the most of the features, in Loading ball screws it is essential to take into account the deformations of the shaft and the nut, since, being the forces high, these deformations are not negligible.

The following diagram shows how the nut and the shaft axis are deformed according to the position of the flange with respect to the support and according to the direction of application of the load.

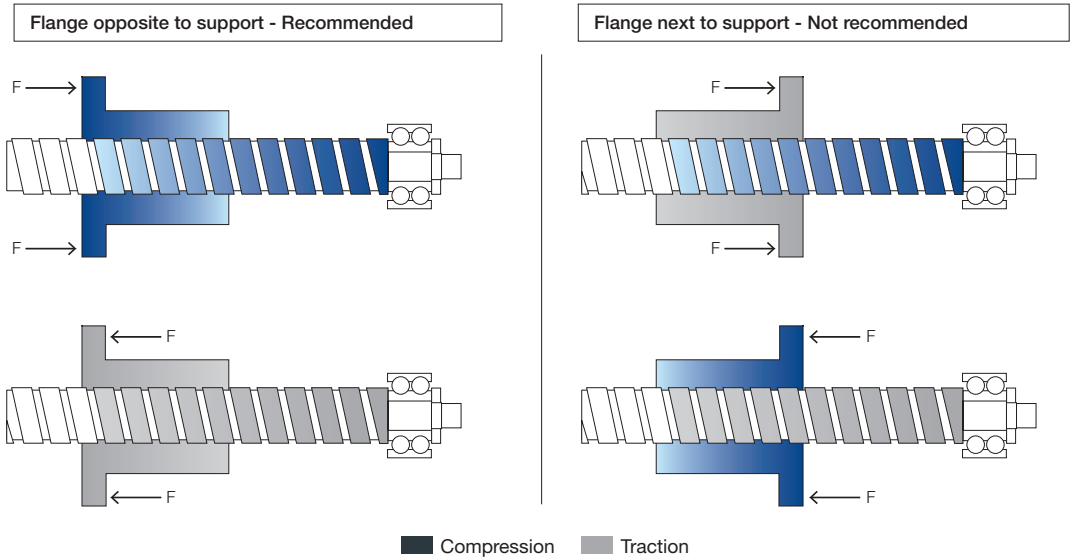

Flange opposite to support:

- When the flange of the nut is positioned at the opposite end to the support where the bearing package is, the shaft and nut are subjected to the SAME type of load:
 - Shaft is in compression and Nut is in compression, if the external load is directed towards the support.
 - Shaft is in traction and nut is in traction, if the external load is directed towards the free end.

As both nut and shaft deform in the same direction, the load distribution between the balls is quite uniform, although if there are many circuits, it is advisable to take into account the magnitude of these deformations to calculate as accurately as possible the actual load that the different balls bear.

Flange next to support:

- When the flange of the nut is positioned in the nut side next to the support where the bearing package is, the shaft and nut are subjected to DIFFERENT type of load:
 - Shaft is in compression and Nut is in traction, if the external load is directed towards the support.
 - Shaft is in traction and nut is in compression, if the external load is directed towards the free end.

The deformation of both elements is in the opposite direction, so the distribution of the external load between the balls is not uniform. In extreme cases with many circuits and very long nuts, the balls in the first circuit can support a much higher load than the balls in the last circuit. The ideal would be to change the position of the flange where the nut is tied to the machine, and put it towards the free end. If it is not possible to change the position of the flange, it is necessary to oversize the nut or take into account the actual load of the balls that bear the greatest load. Another option is to act on the geometry of the nut to improve the load distribution.

Therefore, the recommendation for the position of the flange in Loading ball screws to guarantee uniform load distribution, is always to try to ensure that the clamping flange of the nut to the table is facing the free end, on the opposite side to the support where the bearings that support the load are located.

Tying method

In reference to the tying method of Loading nuts, the most common standard tie is with an 8-hole flange, without cut 'form A', with two cuts 'form B' or with only one cut 'form C'. A direct tie to the side of the nut is also common, with holes inside the flange body. The nut length is greater than indicated in the tables, depending on the depth of the clamping screws.

Loading nut, 8 hole flange design

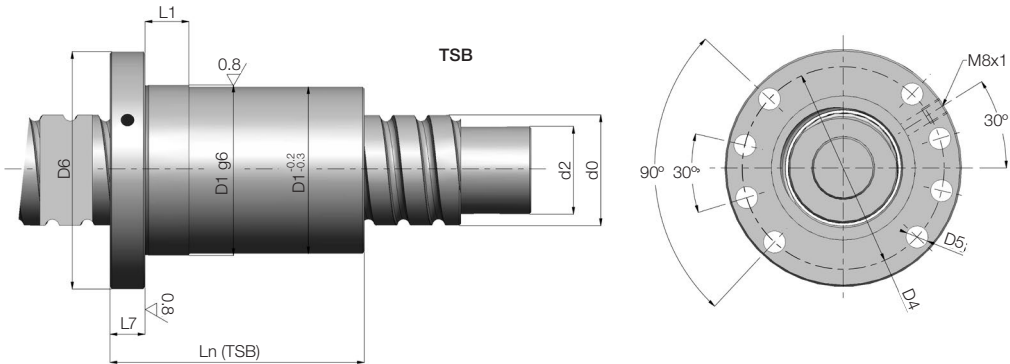

Another possibility, for the ball screws with greater expected external loads, the clamping screws can be very large, or with less commercial non-standard measures, for example M18 or M22. If it is required to reduce the dimensions of the flange or put smaller commercial screws, a solution with 12 clamping holes and offset flange is possible so as not to lengthen the total length of the nut. Of course, 12 clamping holes with side flange and a longer nut length are also possible. For more information consult SHUTON-IPIRANGA.

Loading Nut, 12 hole flange design

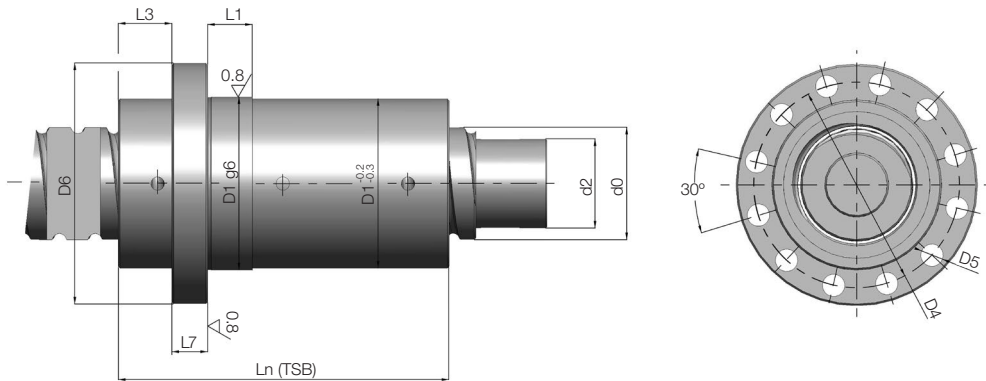

Flange dimensioning example in nut reference IML-TS-B12025-19-12:

Tying method	D4	D6	M	D5	L3
8 hole flange design	227	259	M20	22	No
12 hole flange design	221	247	M16	17,5	45

Lubrication

Another key aspect for the correct performance of the ball screw is the lubrication. In Loading ball screws the most common lubrication option is to use grease. It is important the grease to have good anti-wear and anti-corrosion additives to protect the raceways correctly. The recommended grease quantity is the following:

- IML: $Q_{grease} = \frac{2}{3} V_{int} \text{ [cm}^3\text{]}$
- HDL/PKL: $Q_{grease} \cong V_{int} \text{ [cm}^3\text{]}$

In HDL & PKL technologies, it is recommended to fill the inside of the nut with grease. They are usually very long nuts and for a correct greasing reaching to the end of the nut correctly, several radial holes are made in the body of the nut, every 100mm or so, so it is usual to design a nut of more than 500mm with 5 lubrication holes.

Another lubrication possibility is the oil bath or fluid grease lubrication. If it is required shaft and nut temperature to be kept as stable as possible, the ideal is to immerse the ball screw in an oil bath, or in a fluid grease bath if it is required a greater layer of film for when it works with low speeds, thus better protecting the raceways.

It is especially interesting in cases where a considerable heat generation is expected, due to a high average speed; especially if the load that the ball screw has to bear is so high that it is necessary to put a large number of circuits, with very long nuts where any temperature variation between the nut and the shaft can cause the load not to be distributed evenly between the different circuits. A clear example is plastic injection. For more information on lubrication, please consult pages 52-55 of the Technical description catalogue, or consult SHUTON-IPIRANGA Engineering Department.

TS, Loading Non Preloaded Single Nut

TS, Loading Non Preloaded Single Nut, B-type recirculation



F_{ext} →

← F_{ext}

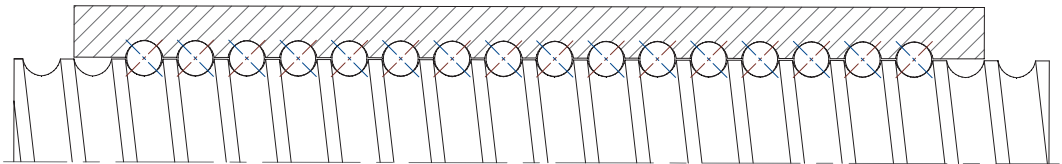

Loading Nut, contact points

Technology	Sectors	Features	Preload	Nut type	Recirc.	Starts	Diameter	Pitch	Ball size	Application
HDL	<ul style="list-style-type: none"> · Injection machine · Presses · Elevators · Actuators · Boarding bridges · Energy · Hexapods · Seismic dampers · Construction 	High dynamics and high load DN up to 170.000. → For applications operated by electric servo drive in extreme condition	NO	TS Single nut	U	1s	80-120	20-50	12	Very high load and moderate rotation speed applications, DN up to 140.000
					B	1s	63-160	16-32	12-25	Very high load and moderate rotation speed applications, DN up to 110.000
2s						63-140	32-50	12-19	Very high load & high linear speed DN up to 110.000	
IML					U	1s	80-120	20-50	12	High load and very high rotation speed applications, DN up to 210.000
					B	1s	50-160	12,7-25	9-19	High load and high rotation speed applications, DN up to 170.000
						2s	63-140	25-50	9-19	High load and very high linear speed applications, DN up to 170.000
PKL	B	1s	63-160	20-32	15-25	Momentary especially extreme peak loads. DN up to 170.000				

For more technical information on the ball screw technology, see *Technical description catalogue*.

For detailed ball screw load and dimensional information, see pages 28-139 in this catalogue.

Customised solutions

Depending on the specific requirements of each application, a ball screw, independently of its technology, can have different customizations in order to optimize its results. Customized solutions include the following:

SPECIAL WIPERS

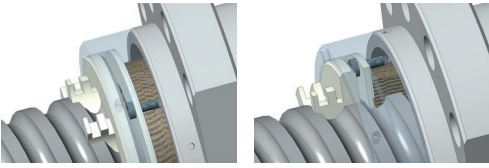

SPECIAL NUTS

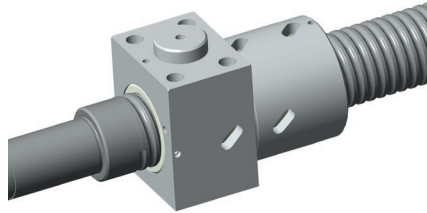

SPECIAL SPINDLE END MACHINING

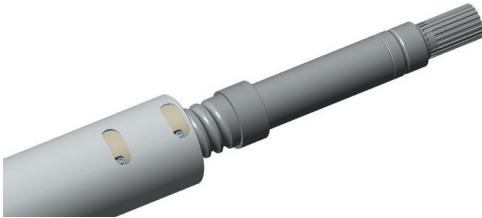

REFRIGERATED SHAFT

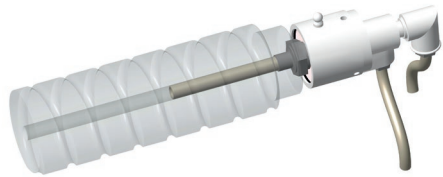

SAFETY NUT

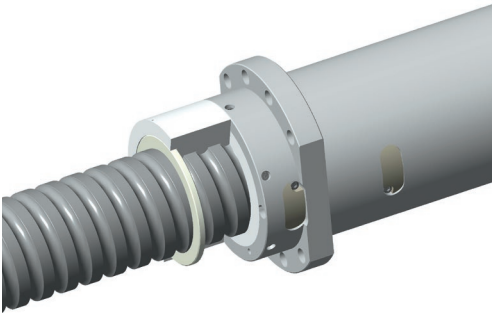

REFRIGERATED NUT

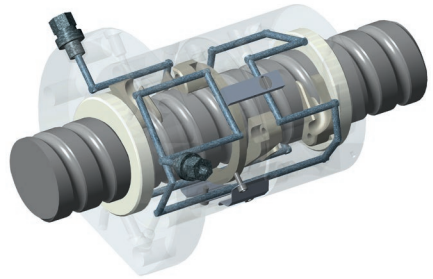

COATING



W-TYPE RECIRCULATION SYSTEM

Engineering Service

SHUTON-IPIRANGA Applied Engineering Department offers its customers comprehensive advice for the selection of the most appropriate ball screw and optimal use for each application, studying the different solutions.

There are two possibilities to carry out the studies:

- Calculate the performance of a specific ball screw with a given set of bearings, motor and transmission system, getting result for:
 - Ball screw fatigue life
 - Table or head feed speed
 - Ball screw critical rotation speed and speed limit
 - Deflections or radial deformations, and advice on rests
 - Estimated noise level [dB]
 - Expected temperature increase
 - Necessary pretensioning force in the event of a pretensioned shaft
 - Grease amount or oil and recommended lubrication
 - Maximum supported force and recommended limit
 - Approximate drive natural frequency and estimated gains of position k_v and speed k_p links
 - Required table acceleration and motor torque
 - Relationship between inertias and servo control response
 - Ball screw force and preload torque
 - Rigidity of nut and entire ball screw
- Calculate which drive (ball screw, motor, transmission system, etc.) is best suited to achieve desired speed, acceleration, rigidity and fatigue life.

One of the most innovative and important aspects of the ball screw study is its provision of approximate motor control values, that is, closed control loop position k_v and speed k_p gains. These values are extremely important for getting an idea of a machine's dynamics. Two or more potential drives can be compared during the design phase of the machine, revealing the drive component that limits the machine's dynamic behaviour* (ball screw, bearings, pulleys, etc.).

SHUTON-IPIRANGA Engineering Service team has broad experience in the study of different applications keeping close collaboration with leading manufacturers in different application fields.

Technical application forms can be requested at <https://www.shuton.com/en/engineering-service> or through your closest Shuton-Ipiranga contact.

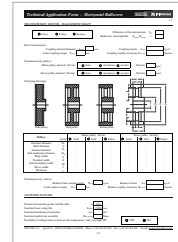
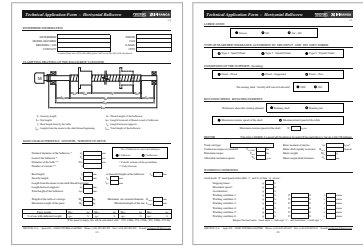

'Technical Form'

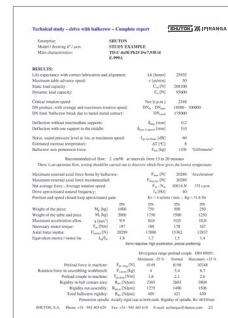

'Study report'

* The programme cannot know if it really is the drive that limits machine dynamics, as it has not data about the structure. If it is the structure that is the limiting factor, improvements to any of the drive elements will have no effect.

BALL SCREW ORDERING INFORMATION

Simplified application form for ball screw configuration:

Required information for ball screw order



Enterprise: _____ Drawing: _____ Date: _____

The indispensable data for the manufacturing a Ballscrew are the following:

- Type of nut: Double TD Compact TC Single TS
- Tying type: Lateral Flange Centred Flange Cylindrical Nut
- Flange shape: A Shape B Shape C Shape
- Nominal diameter, d_θ : _____
- Lead, P_h : _____
- Ball diameter, D_B : _____ and material: Steel Ceramics
- Quantity of circuits, i : _____
- Threaded length, L_{hr} : _____
- Ball recirculation system: External 'U' Internal 'S'
- Manufacturing tolerance: ISO1 ISO3 ISO5 ISO7 ISO10

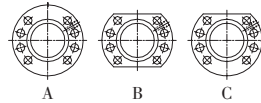

The following data is necessary if it is required to have the proper preload and to put the wipers and recirculation systems in the suitable position according to machine requirements and SHUTON to check if there is any problem of loads or speed:

- Nut position assembled in machine, oiling angle with the vertical, τ : _____ 'see drawing'
- Ballscrew rotation speed N : _____ r.p.m. or table feed speed v : _____ m/min
- Stroke l_1 : _____ and security lengths l_{e1} : _____ and l_{e2} : _____ between the final position of the nut in each end and the end of thread of the shaft

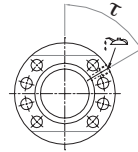

- Distances between end of thread and each support l_{ap1} : _____ y l_{ap2} : _____ o l_{ap} : _____ si $l_{ap1}=l_{ap2}$

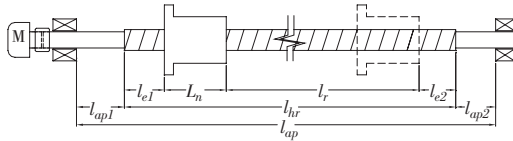

- Disposition: Horizontal Vertical without counterweight Vertical with balanced counterweight
- Lubrication system: Grease Oil Air-Oil
- Rotating element: Rotary shaft Rotary nut
- Fixed-Fixed Fixed-Supported Fixed-Free Supported-Supported
- Pretensed shaft Non pretensed tied shaft Axially free shaft in one of the supports
- Maximum machining force $F_{max.mec}$: _____ N
- Maximum inertia force $F_{max.inertia}$: _____ N, or combination that gives the highest result of total weight to move M : _____ kg multiplied by acceleration of the table a : _____ m/s²

If it is required SHUTON to check the life expectancy, is necessary to fill in with as real data as possible the duty cycle with percentages of time, machining forces and table feed speeds:

Stopping Times: q : _____ %
 Maximum Speed: q : _____ %
 Acceleration: q : _____ %

Working Condition 1:	q : _____ %	F : _____ N	v : _____ m/min
Working Condition 2:	q : _____ %	F : _____ N	v : _____ m/min
Working Condition 3:	q : _____ %	F : _____ N	v : _____ m/min
Working Condition 4:	q : _____ %	F : _____ N	v : _____ m/min
Working Condition 5:	q : _____ %	F : _____ N	v : _____ m/min
Working Condition 6:	q : _____ %	F : _____ N	v : _____ m/min

Is important the customer to facilitate all these data when doing the order, so as the operation is good and the Ballscrew is well dimensioned.

The aim is to perform a basic study to detect if the ball screw will suffer speed, load, life, rigidity, noise or temperature issues. Where operation can be improved, SHUTON-IPIRANGA will contact the customer to inform them of the problem and propose an alternative.

Information about machine nut position can assist our designers in achieving the optimum distribution of internal components, for smoother and longer-lasting operation.

Technical study - drive with ball screw - Basic report



Enterprise: **SHUTON**
 Model / drawing n° / axis: **study example**
 Main characteristics: **TD-U do50 Ph25 Dw7,938 i4**
 Date [D/M/Y]: **07/07/2008**
 Study code, "put on drawing": **E-999**

Double fixed nut with external recirculation 'U'

Nominal diameter:	d_0 [mm]	50
Lead:	P_h [mm]	25
Diameter of the balls:	D_w [mm]	7,938
Number of circuits with balls inside nut:	i	4
Real length done by the table (useful travel):	l_r [mm]	1800
Length between supports of end of the ballscrew:	l_{sup} [mm]	2110
External diameter of the nut:	D_j [mm]	82
Length of the nut:	L_n [mm]	260
Total maximum mass to be moved by ballscrew:	M [kg]	2000
Maximum rotation speed:	N [r.p.m.]	2000

Condition of ballscrew end supports:
 Fixed-Fixed - Pretensed spindle

Class of tolerance:
 ISO 3

Nut lubrication:
 Oil - Air

	Time	Machining force [N]	Speed [m/min]	Rotation speed [r.p.m.]
Duty cycle [%]	20	0	0	0
Stopping times:	10	0	50	2000
Maximum speed:	10	20196	25	1000
Acceleration: $a: 10m/s^2$:	15	3750	10	400
Working condition 1:	15	7500	7,5	300
Working condition 2:	15	11250	5	200
Working condition 3:	15	15000	2,5	100
Working condition 4:				

RESULTS:

Basic study: horizontal shaft, or vertical shaft without counterweight

Life expectancy with correct lubrication and alignment:	L_h [hours]	24917
Maximum table advance speed:	v [m/min]	50
Static load capacity:	C_{0a} [N]	208100
Dynamic load capacity:	C_a [N]	95600
Maximum external axial force borne by ballscrew:	F_{max} [N]	20196 'Acceleration'
Maximum external axial force recommended:	$F_{max,rec}$ [N]	21037
Critical rotation speed	N_{cr} [r.p.m.]	2891
DN product, with average and maximum rotation speed:	$DN_m - DN_{max}$	22500 - 100000
DN limit 'ballscrew break due to metal-metal contact':	DN_{crash}	200000
Deflection without intermediate supports:	δ_{max} [mm]	0,2
Deflection with one support in the middle:	$\delta_{max,1support}$ [mm]	0,0
Noise, sound pressure level at 1m, at maximum speed:	$L_{p,1m,Nmax}$ [dB]	69
Ballscrew without refrigeration, estimated increase temperature:	ΔT [°C]	8

Oil-air' lubrication, an oil flow of 0,1 - 0,2 cm³ each 5 minutes is recommended

Continuous air flow 2 - 4 bar. If oil is not reaching the nut, either increase the flow or reduce the time

Divergence range preload couple DIN 69051: Minimum: -25 % Normal Maximum: +25 %

Preload force:	F_{pr} [N]	6375	8500	10625
Rotation force:	F_r [kg]	4	5,4	6,7
Preload couple:	T_{pr} [Nm]	1,6	2,2	2,7
Rigidity in ball contact area:	$R_{b/t}$ [N/μm]	2394	2635	2838
Rigidity nut assembly:	$R_{nut,ar}$ [N/μm]	1290	1417	1524
Total ballscrew rigidity:	R_{tot} [N/μm]	436	450	460

Pretension spindle. Axially rigid seat at both ends. Rigidity of spindle, R_s : 658N/um

Quick selection of a ball screw

Essential drive design starting data is:

- Mass M to be moved with the drive, 'table+part'
- The travel l_r or distance the table is moved
- Feed speed v
- Acceleration a
- Duty cycle

First of all, it is necessary to select the family of the ball screw:

· **With Preload: Positioning ball screws, Technologies COMPLEX or PRIME**

Now find out the maximum force to be applied to the ball screw, this may be the inertia force, or machining force:

$$F_{max} \approx MAX (M a ; F_{max,machining})$$

The preload force should be at least: $F_{pr} \geq \frac{F_{max}}{2,83}$

Ball screw fatigue life depends on the entire duty cycle, although initially, a ball screw with a preload of 8% of dynamic load can be chosen, and therefore:

$$C_a \approx \frac{F_{pr}}{0,08} \longrightarrow C_a \geq \frac{F_{max}}{2,83 \times 0,08} \longrightarrow C_a \geq 4,5 F_{max}$$

In the Load and Dimension tables, two or three combinations can be selected that meet this condition.

$$\text{From the tables} \Rightarrow d_0 ; D_w ; i$$

The shaft lead must comply with: $P_h \geq \frac{v}{N_{advised}}$

From the DN table on page 50 maximum rotation speed is obtained in order to keep temperature under control, according to lubrication type and ball recirculation system. It is recommended not to work over 75% of limit speed:

$$N_{advised} = 0,75 \times N_{lim} = 0,75 \frac{DN}{d_0}$$

· **Without Preload: Loading and transport ball screws, Technologies IML, HDL, PKL, TMBS**

The first thing is to choose the lead (P_h) according to $N_{advised}$, and then in the tables choose a combination ($d_0; D_w; i$) so that $C_{oa} > 5 * F_{max}$, and calculate life with the cycle to verify that it is sufficient.

If it is required a shorter lead or a higher rotation speed, it is recommended to refer the case to SHUTON-IPIRANGA for a detailed study.

The greater P_h , the lower the temperature and noise and longer the life.

Fatigue life and rigidity can be calculated with d_0, P_h, D_w, i . (see pages 39-42)

If fatigue life is low, N can be reduced with a greater P_h value, or if not choose a ball screw with a higher dynamic load C_a , increasing d_0, D_w or i . Also F_{pr} can be reduced at the expense of less rigidity.

If ball screw rigidity is low, check which is most important, shaft rigidity or nut rigidity. If it is the shaft then it can be pretensioned or the nominal diameter d_0 increased. If it is the nut increase d_0 or i , or also increase F_{pr} , at the expense of reducing fatigue life.

Lastly, check static load, bending, critical rotation speed and deflection or radial deformation; in case it is necessary to carry out one of the following actions:

- Increase the nominal diameter d_0
- Use a rotating nut
- Change the support mounting method
- Insert a rest or intermediate support

*e.g. $M:2000kg, v:50m/min, a:5m/s^2, F_{mec,max}:15000N$ without axial play
Preload & high speed →
COMPLEX family
Inertia force:*

$$F_{in} \approx M a = 2000 \times 5 = 10000 N$$

$$F_{max} = 15000 N$$

$$F_{pr} \geq \frac{15000}{2,83} = 67500 N$$

$$C_a \geq 4,5 \times 15000 = 67500 N$$

Can be:

$$A/ d_0:40 - D_w:6,35 - i:5$$

$$B/ d_0:50 - D_w:6,35 - i:4$$

$$C/ d_0:50 - D_w:7,938 - i:3$$

Speed is high, and therefore we will use external 'U' recirculation and oil lubrication. $DN: 180000$

For the nut to be as short as possible, we start with option C, $d_0:50 - D_w:7,938 - i:3$

$$N_{advised} = 0,75 \times \frac{180000}{50} = 2700$$

$$P_h \geq \frac{50 \times 1000}{2700} = 18,5$$

With $P_h:20$ it is sufficient, although if we use $P_h:25$, fatigue life, temperature and noise will improve.

Reference definition (nomenclature)

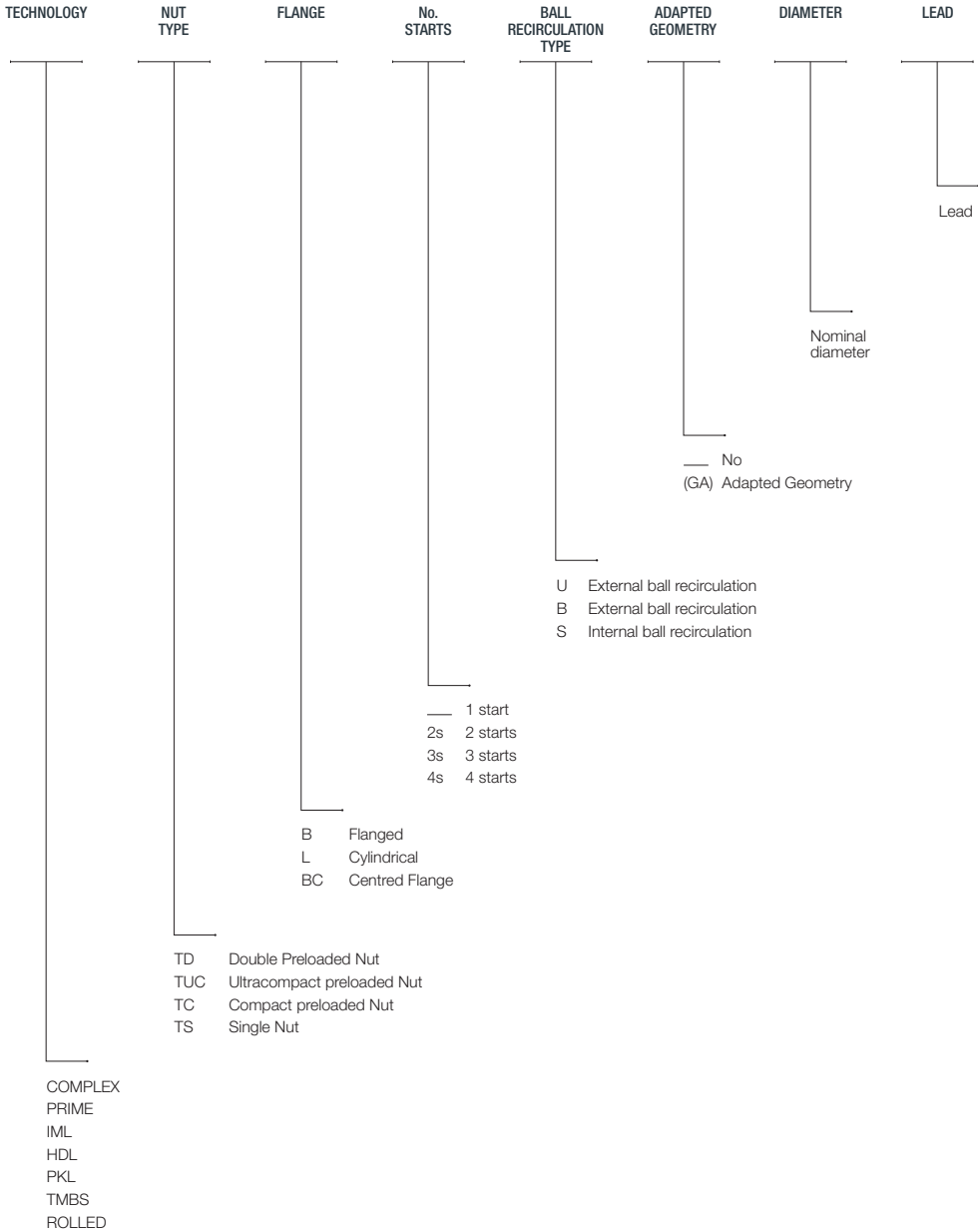

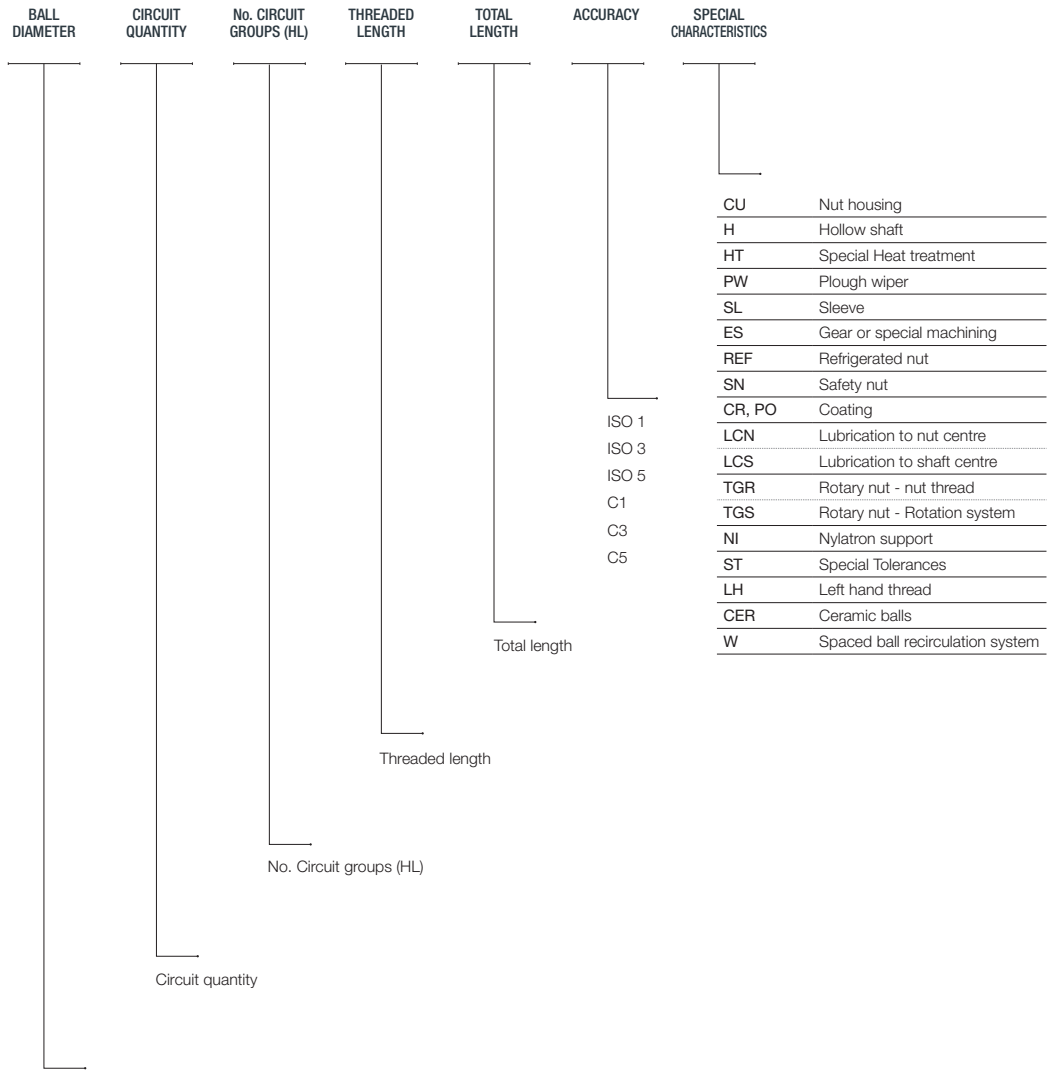

D _w	3,175	3,969	4,762	6,35	7,144	7,938	9,525	11,11	12,7	15,875	19,05	25,4
Abbreviation	3	4	5	6	7	8	9	11	12	15	19	25

Ball screws according fastening method

In most cases, ball screws are fastened to the table via a lateral flange.

This flange can be a customer's design, although it is recommended that one of the 3 standard forms defined by standards DIN69051 and ISO3408 is chosen:

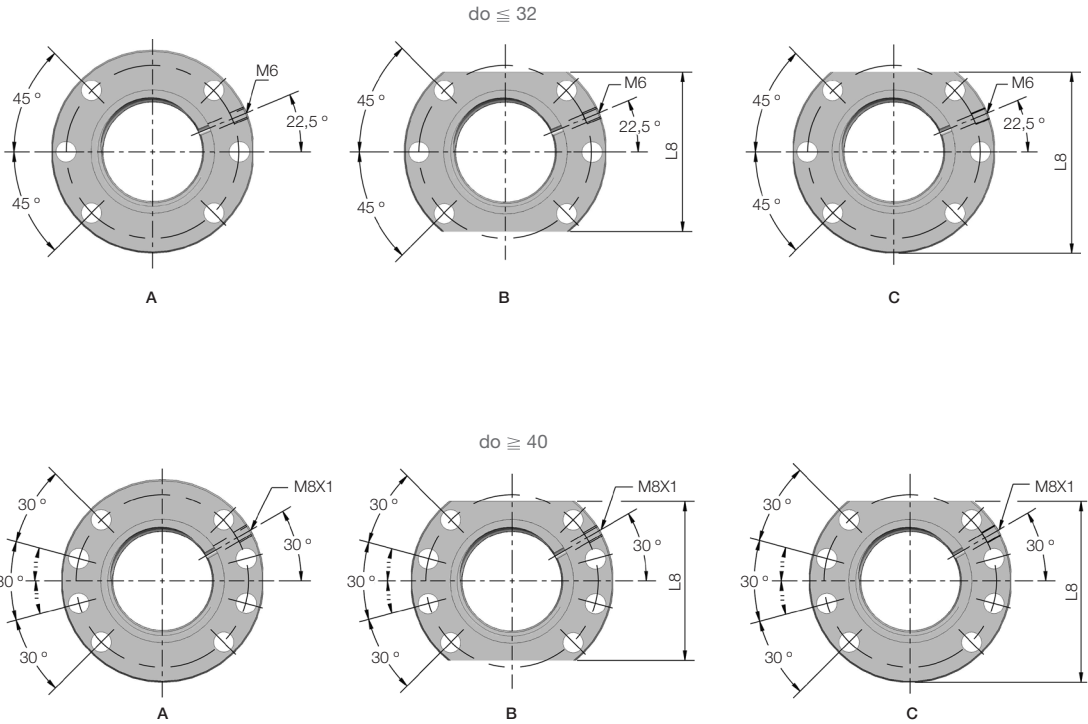

Wherever possible, a type A flange is recommended, above all if the assembly involves a rotating nut, so that the nut is balanced. SHUTON-IPIRANGA recommends a centred flange when radial forces cannot be entirely eliminated from the nut. Sometimes there is no other option but to use a cylindrical nut and fasten to the table with a keyway.

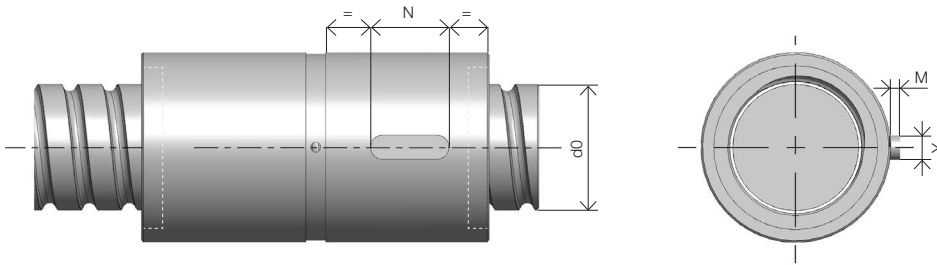

The standard dimensions for this keyway are a function of the nominal diameter of the ball screw and the dynamic load according to the following tables:

d_0	Y	M
20-25	6	2
32-40	8	3
50-63	10	4
80-100	12	4
120-160	14	6

C_a	N
< 25000	15
< 50000	20
< 100000	30
< 150000	40
< 250000	50
≥ 250000	60

IML, HDL, PKL TECHNOLOGIES

High dynamics and HIGH LOAD ball screws for injection molding machines, presses and other heavy duty applications operated by electric servo drive in extreme conditions.

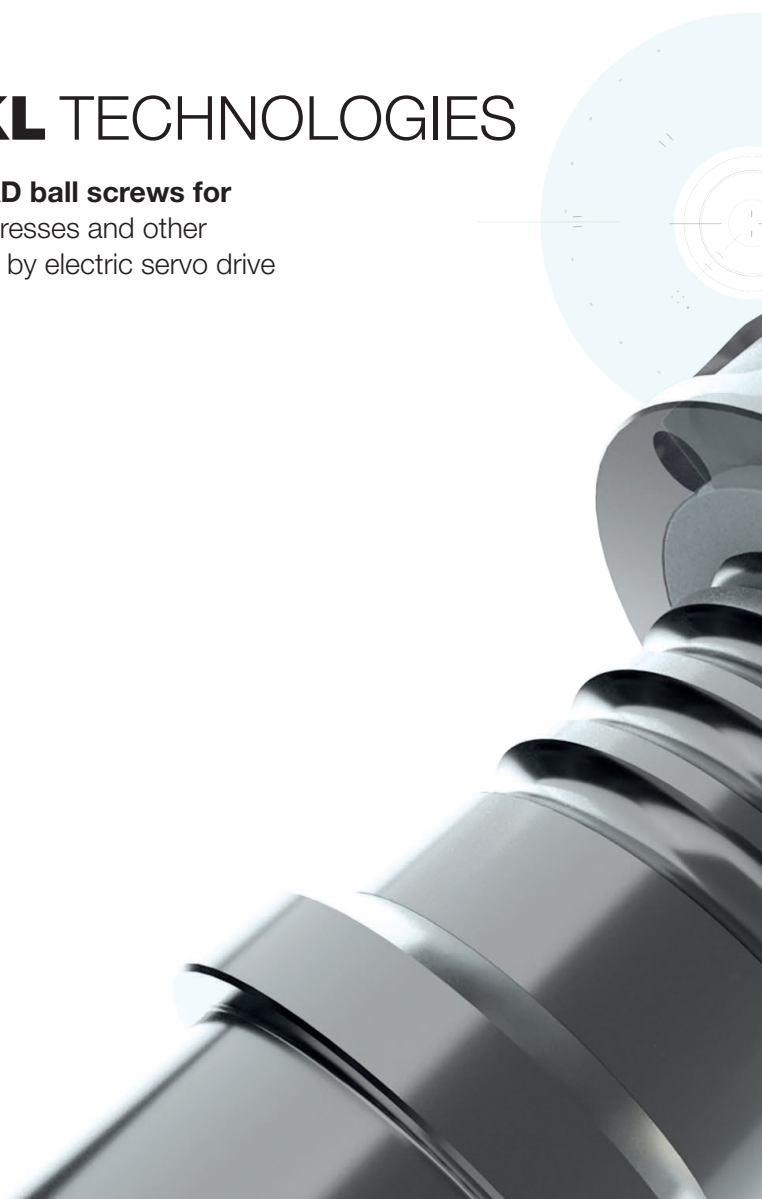



IML, HDL, PKL TECHNOLOGIES

U-type recirculation system

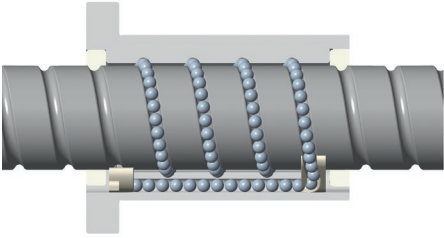

B-type recirculation system

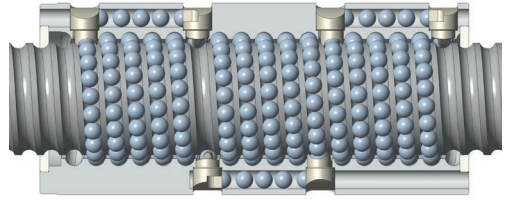

HIGH LOADS Single Nut

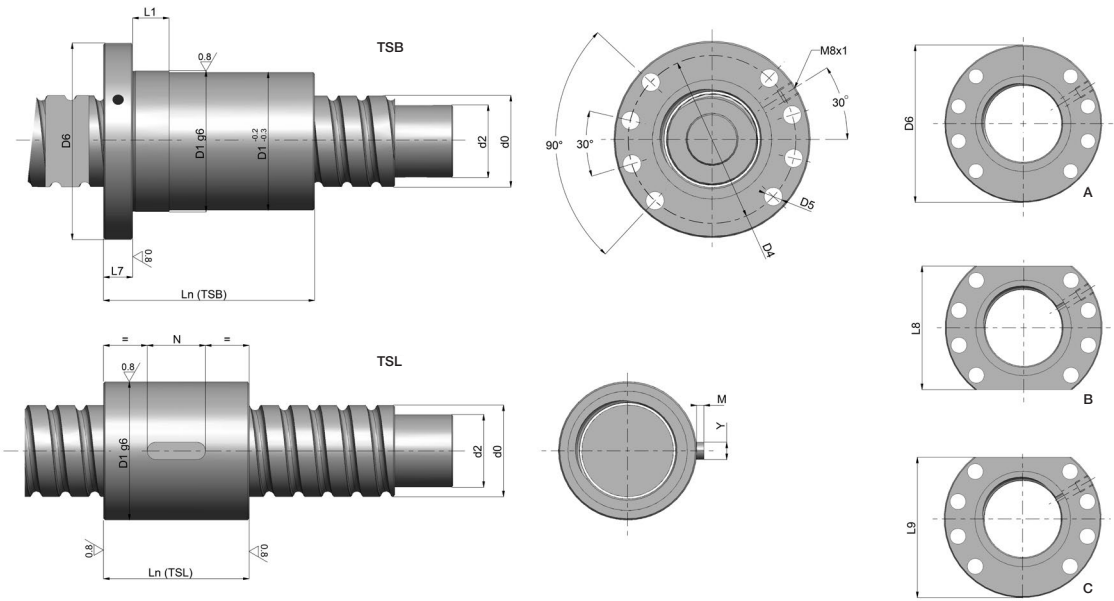

Types of HIGH LOADS nuts depending on application:

Technology	Sectors	Features	Preload	Nut type	Recirc.	Starts	Diameter	Pitch	Ball size	Application
IML	<ul style="list-style-type: none"> · Injection machine · Presses · Elevators · Actuators 	High dynamics and high load DN up to 170.000. → For applications operated by electric servo drive in extreme condition	NO	TS Single nut	U	1s	80-120	20-50	12	High load and very high rotation speed applications, DN up to 210.000
					B	1s	50-160	12,7-25	9-19	High load and high rotation speed applications, DN up to 170.000
						2s	63-140	25-50	9-19	High load and very high linear speed applications, DN up to 170.000
HDL	<ul style="list-style-type: none"> · Boarding bridges · Energy · Hexapods · Seismic dampers · Construction 	→ For applications operated by electric servo drive in extreme condition	NO	TS Single nut	U	1s	80-120	20-50	12	Very high load and moderate rotation speed applications, DN up to 140.000
					B	1s	63-160	16-32	12-25	Very high load and moderate rotation speed applications, DN up to 110.000
						2s	63-140	32-50	12-19	Very high load & high linear speed DN up to 110.000
PKL					B	1s	63-160	20-32	15-25	Momentary especially extreme peak loads. DN up to 170.000

Loading ball screw technologies

Depending on the application requirement of load capacity and speed, and in order to obtain the optimum life results in each case, SHUTON-IPIRANGA has developed three different Loading ball screw technologies:

Depending on the application's requirement of load capacity and speed, and in order to obtain the optimum life results in each case, SHUTON-IPIRANGA high load ball screws range has been optimized in three types of technology: IML, HDL and PKL, specially adapted to different types of application.

IML HIGH LOAD TECHNOLOGY

- It is designed for high load and high speed applications with DN up to 170.000.
- It is indicated when there is a high load resulting in high average force and at the same time medium and high speeds, resulting in a medium to high average speed.
- IML technology enables working temperature to be kept controlled.

HDL HIGH LOAD TECHNOLOGY

- It is designed for very high load and moderate speed applications with DN up to 110.000.
- It is indicated when there is a high load, resulting in high average force, and at the same time low speeds, resulting in a low average speed.
- It is the option that gives a greatest dynamic, static load and rigidity.

PKL HIGH LOAD TECHNOLOGY

- It is designed for applications with momentary extreme peak loads, where the average force does not have to be particularly high.
- Possibility of high speed, both in peak speed as in average speeds.

High Load IML TS Single nut, DN up to 170.000

Ball screw reference	Number of starts	Nominal diameter (mm)	Lead (mm)	Ball Diameter (mm)	Root diameter (mm)	Circuits	Dynamic load capacity	Static load capacity	Peak load CO-CO TR-TR 'TS'	Nut length
	$l/2$	d_0	P_h	D_w	d_2	i	C_a [kN]	C_{oa} [kN]	F_{max} [kN]	L_{nstd} [mm]
IML TSB(2S)-U 40-20-6-2	2	40	20	6,35	34,5	2	48,7	91,1	44	75
IML TSB(2S)-U 40-20-6-3	2	40	20	6,35	34,5	3	67,8	143,1	70	95
IML TSB(2S)-U 40-20-6-4	2	40	20	6,35	34,5	4	87,8	197,7	95	115
IML TSB(2S)-U 40-20-6-5	2	40	20	6,35	34,5	5	106,5	249,8	120	135
IML TSB(2S)-U 40-25-8-2	2	40	25	7,938	33,3	2	66,1	116,1	40	92
IML TSB(2S)-U 40-25-8-3	2	40	25	7,938	33,3	3	94,3	189,2	65	117
IML TSB(2S)-U 40-25-8-4	2	40	25	7,938	33,3	4	121	258	90	142
IML TSB(2S)-U 40-30-8-2	2	40	30	7,938	33,3	2	65,4	115,2	40	99
IML TSB(2S)-U 40-30-8-3	2	40	30	7,938	33,3	3	93,4	187,8	65	129
IML TSB(2S)-U 40-40-8-2	2	40	40	7,938	33,3	2	65,4	117,2	40	113
IML TSB(2S)-U 40-50-8-2	2	40	50	7,938	33,3	2	64,9	118,6	40	125
IML TSB(2S)-U 40-60-8-2	2	40	60	7,938	33,3	2	64,1	119,3	39	142
IML TSB-B 50-12,7-9-2	1	50	12,7	9,525	42,2	2	62,3	107,9	35	65
IML TSB-B 50-12,7-9-3	1	50	12,7	9,525	42,2	3	88,1	173,3	55	78
IML TSB-B 50-12,7-9-4	1	50	12,7	9,525	42,2	4	113,8	238,8	75	91
IML TSB-B 50-12,7-9-5	1	50	12,7	9,525	42,2	5	140	308,2	100	103
IML TSB-B 50-12,7-9-6	1	50	12,7	9,525	42,2	6	164,5	373,6	120	116
IML TSB-B 50-12,7-9-7	1	50	12,7	9,525	42,2	7	188,5	439,1	130	129
IML TSB-B 50-12,7-9-8	1	50	12,7	9,525	42,2	8	204,5	477,6	150	148
IML TSB-B 50-12,7-9-9	1	50	12,7	9,525	42,2	9	228,9	547	170	161
IML TSB-B 50-12,7-9-10	1	50	12,7	9,525	42,2	10	252,8	616,3	190	173
IML TSB-B 50-12,7-9-11	1	50	12,7	9,525	42,2	11	274,4	677,9	210	182
IML TSB-B 50-15-9-2	1	50	15	9,525	42,2	2	62,2	107,7	35	70
IML TSB-B 50-15-9-3	1	50	15	9,525	42,2	3	87,9	173,1	55	85
IML TSB-B 50-15-9-4	1	50	15	9,525	42,2	4	113,6	238,5	75	100
IML TSB-B 50-15-9-5	1	50	15	9,525	42,2	5	139,8	307,8	95	115
IML TSB-B 50-15-9-6	1	50	15	9,525	42,2	6	164,3	373,2	120	130
IML TSB-B 50-15-9-7	1	50	15	9,525	42,2	7	188,3	438,6	130	145
IML TSB-B 50-15-9-8	1	50	15	9,525	42,2	8	204,2	477,1	150	167
IML TSB-B 50-15-9-9	1	50	15	9,525	42,2	9	228,5	546,3	170	182
IML TSB-B 50-16-9-2	1	50	16	9,525	42,2	2	62,2	107,7	35	72
IML TSB-B 50-16-9-3	1	50	16	9,525	42,2	3	87,9	173	55	88
IML TSB-B 50-16-9-4	1	50	16	9,525	42,2	4	113,5	238,4	75	104
IML TSB-B 50-16-9-5	1	50	16	9,525	42,2	5	139,7	307,6	95	120
IML TSB-B 50-16-9-6	1	50	16	9,525	42,2	6	164,2	373	120	136
IML TSB-B 50-16-9-7	1	50	16	9,525	42,2	7	188,1	438,4	130	152

- C_a and C_{oa} : Modified static and dynamic load capacities, calculated according to DIN 69051/4 standard and ISO3408/5. See Technical description catalogue.

- Check with SHUTON-IPIRANGA in case higher loads or more adjusted nut dimensions are required.

- Check external maximum axial force in the two senses.

For the indicated leads, in case C_a and C_{oa} requirements is lower, there is possibility of smaller size balls.

Maximum force (Peak load CO-CO and TR-TR) calculated with the flange/nut clamping in opposite position to the main support of the shaft, with same load type (traction or compression) in both nut and shaft. For same-side clamping, so different type of load, contact SHUTON-IPIRANGA as peak load is lower.

Nut dimensions									Grease quantity TS
$D_{1, std}$	$D_{1, min}$	D_4	D_6	D_5	L_7	L_1	L_8	L_9	$Q_{Gr} [cm^3]$
65	(63)	78	93	9	18	20	70	81,5	full=10
65	(63)	78	93	9	18	20	70	81,5	full=13
65	(63)	78	93	9	18	20	70	81,5	full=16
65	(63)	78	93	9	18	20	70	81,5	full=19
70		85	100	9	18	25	75	87,5	full=16
70		85	100	9	18	25	75	87,5	full=21
70		85	100	9	18	25	75	87,5	full=25
70		85	100	9	18	25	75	87,5	full=17
70		85	100	9	18	25	75	87,5	full=22
70		85	100	9	18	25	75	87,5	full=18
70		85	100	9	18	25	75	87,5	full=18
70		85	100	9	18	25	75	87,5	full=20
85		105	125	13,5	35	25	90	107,5	full=25
85		105	125	13,5	35	25	90	107,5	full=29
85		105	125	13,5	35	25	90	107,5	full=33
85		105	125	13,5	35	25	90	107,5	full=36
85		105	125	13,5	35	25	90	107,5	full=40
85		105	125	13,5	35	25	90	107,5	full=45
85		105	125	13,5	35	25	90	107,5	full=54
85		105	125	13,5	35	25	90	107,5	full=58
85		105	125	13,5	35	25	90	107,5	full=61
85		105	125	13,5	35	25	90	107,5	full=63
85		105	125	13,5	35	25	90	107,5	full=25
85		105	125	13,5	35	25	90	107,5	full=29
85		105	125	13,5	35	25	90	107,5	full=33
85		105	125	13,5	35	25	90	107,5	full=37
85		105	125	13,5	35	25	90	107,5	full=42
85		105	125	13,5	35	25	90	107,5	full=47
85		105	125	13,5	35	25	90	107,5	full=56
85		105	125	13,5	35	25	90	107,5	full=61
85		105	125	13,5	35	25	90	107,5	full=24
85		105	125	13,5	35	25	90	107,5	full=29
85		105	125	13,5	35	25	90	107,5	full=34
85		105	125	13,5	35	25	90	107,5	full=38
85		105	125	13,5	35	25	90	107,5	full=43
85		105	125	13,5	35	25	90	107,5	full=48

SHUTON-IPIRANGA advises to use the dimensions of the tables, although it is possible to manufacture ball screw with other dimensions. In brackets () second options.

Smaller nut diameters than the first option of the table can reduce the rigidity of the assembly between 5 and 10%. Please consult SHUTON-IPIRANGA.

High Load IML TS Single nut, DN up to 170.000

Ball screw reference	Number of starts	Nominal diameter (mm)	Lead (mm)	Ball Diameter (mm)	Root diameter (mm)	Circuits	Dynamic load capacity	Static load capacity	Peak load CO-CO TR-TR 'TS'	Nut length
	$1/2$	d_0	P_h	D_w	d_2	i	C_a [kN]	C_{oa} [kN]	F_{max} [kN]	$L_{n, std}$ [mm]
IML TSB-B 50-16-9-8	1	50	16	9,525	42,2	8	204	476,8	150	176
IML TSB-B 50-16-9-9	1	50	16	9,525	42,2	9	228,3	546	170	187
IML TSB(2S)-U 50-20-6-2	2	50	20	6,35	44,5	2	54,6	116,4	55	75
IML TSB(2S)-U 50-20-6-3	2	50	20	6,35	44,5	3	76,7	185,2	90	95
IML TSB(2S)-U 50-20-6-4	2	50	20	6,35	44,5	4	98,1	251,3	120	115
IML TSB(2S)-U 50-20-6-5	2	50	20	6,35	44,5	5	119,8	320,1	150	135
IML TSB(2S)-U 50-20-6-6	2	50	20	6,35	44,5	6	140,3	386,2	180	155
IML TSB(2S)-U 50-20-6-7	2	50	20	6,35	44,5	7	161	455	210	175
IML TSB-B 50-20-9-2	1	50	20	9,525	42,2	2	61,9	107,4	35	80
IML TSB-B 50-20-9-3	1	50	20	9,525	42,2	3	87,6	172,6	55	100
IML TSB-B 50-20-9-4	1	50	20	9,525	42,2	4	114,3	241,6	75	120
IML TSB-B 50-20-9-5	1	50	20	9,525	42,2	5	139,2	306,8	95	140
IML TSB-B 50-20-9-6	1	50	20	9,525	42,2	6	163,6	372	120	160
IML TSB-B 50-20-9-7	1	50	20	9,525	42,2	7	187,5	437,2	130	180
IML TSB(2S)-U 50-25-8-2	2	50	25	7,938	43,3	2	76,5	153,7	55	89
IML TSB(2S)-U 50-25-8-3	2	50	25	7,938	43,3	3	106,6	241,5	85	114
IML TSB(2S)-U 50-25-8-4	2	50	25	7,938	43,3	4	137,9	333,8	110	139
IML TSB(2S)-U 50-25-8-5	2	50	25	7,938	43,3	5	168,6	426	140	164
IML TSB(2S)-U 50-25-8-6	2	50	25	7,938	43,3	6	197,4	513,8	170	189
IML TSB(2S)-U 50-25-9-2	2	50	25	9,525	42,2	2	95,6	178,2	55	98
IML TSB(2S)-U 50-25-9-3	2	50	25	9,525	42,2	3	137,2	292,8	95	123
IML TSB(2S)-U 50-25-9-4	2	50	25	9,525	42,2	4	176,4	401	130	148
IML TSB(2S)-U 50-25-9-5	2	50	25	9,525	42,2	5	214,9	509,2	160	173
IML TSB(2S)-U 50-25-9-6	2	50	25	9,525	42,2	6	254,2	623,8	190	198
IML TSB(2S)-U 50-30-9-2	2	50	30	9,525	42,2	2	95	177,3	55	103
IML TSB(2S)-U 50-30-9-3	2	50	30	9,525	42,2	3	136,3	291,3	95	133
IML TSB(2S)-U 50-30-9-4	2	50	30	9,525	42,2	4	175,3	399	130	163
IML TSB(2S)-U 50-30-9-5	2	50	30	9,525	42,2	5	215,3	513	160	193
IML TSB(2S)-U 50-40-9-2	2	50	40	9,525	42,2	2	95,6	181,4	55	114
IML TSB(2S)-U 50-40-9-3	2	50	40	9,525	42,2	3	134,1	287,7	90	154
IML TSB(2S)-U 50-40-9-4	2	50	40	9,525	42,2	4	174,3	400,3	120	194
IML TSB(2S)-U 50-50-9-2	2	50	50	9,525	42,2	2	93,7	178,6	55	125
IML TSB(2S)-U 50-50-9-3	2	50	50	9,525	42,2	3	133,3	289,4	90	175
IML TSB(2S)-U 50-60-9-2	2	50	60	9,525	42,2	2	93,6	181,3	55	142
IML TSB-B 63-12,7-9-2	1	63	12,7	9,525	55,2	2	71	140,8	46	65
IML TSB-B 63-12,7-9-3	1	63	12,7	9,525	55,2	3	100,5	226,9	75	78

- C_a and C_{oa} : Modified static and dynamic load capacities, calculated according to DIN 69051/4 standard and ISO3408/5. See Technical description catalogue.

- Check with SHUTON-IPIRANGA in case higher loads or more adjusted nut dimensions are required.

- Check external maximum axial force in the two senses.

For the indicated leads, in case C_a and C_{oa} requirements is lower, there is possibility of smaller size balls.

Maximum force (Peak load CO-CO and TR-TR) calculated with the flange/nut clamping in opposite position to the main support of the shaft, with same load type (traction or compression) in both nut and shaft. For same-side clamping, so different type of load, contact SHUTON-IPIRANGA as peak load is lower.

Nut dimensions									Grease quantity TS
$D_{1, std}$	$D_{1, min}$	D_4	D_6	D_5	L_7	L_1	L_8	L_9	$Q_{Gr} [cm^3]$
85		105	125	13,5	35	25	90	107,5	full=58
85		105	125	13,5	35	25	90	107,5	full=59
75		93	110	11	18	25	85	97,5	full=13
75		93	110	11	18	25	85	97,5	full=16
75		93	110	11	18	25	85	97,5	full=20
75		93	110	11	18	25	85	97,5	full=23
75		93	110	11	18	25	85	97,5	full=27
75		93	110	11	18	25	85	97,5	full=31
85		105	125	13,5	35	25	90	107,5	full=25
85		105	125	13,5	35	25	90	107,5	full=30
85		105	125	13,5	35	25	90	107,5	full=35
85		105	125	13,5	35	25	90	107,5	full=41
85		105	125	13,5	35	25	90	107,5	full=46
85		105	125	13,5	35	25	90	107,5	full=53
82		100	118	11	18	25	92	105	full=19
82		100	118	11	18	25	92	105	full=26
82		100	118	11	18	25	92	105	full=31
82		100	118	11	18	25	92	105	full=37
82		100	118	11	18	25	92	105	full=43
90	(85)	108 (103)	125 (120)	11	20	25	95 (90)	110 (105)	full=22
90	(85)	108 (103)	125 (120)	11	20	25	95 (90)	110 (105)	full=29
90	(85)	108 (103)	125 (120)	11	20	25	95 (90)	110 (105)	full=36
90	(85)	108 (103)	125 (120)	11	20	25	95 (90)	110 (105)	full=44
90	(85)	108 (103)	125 (120)	11	20	25	95 (90)	110 (105)	full=52
90	(85)	108 (103)	125 (120)	11	20	25	95 (90)	110 (105)	full=22
90	(85)	108 (103)	125 (120)	11	20	25	95 (90)	110 (105)	full=30
90	(85)	108 (103)	125 (120)	11	20	25	95 (90)	110 (105)	full=39
90	(85)	108 (103)	125 (120)	11	20	25	95 (90)	110 (105)	full=48
90	(85)	108 (103)	125 (120)	11	20	25	95 (90)	110 (105)	full=25
90	(85)	108 (103)	125 (120)	11	20	25	95 (90)	110 (105)	full=36
90	(85)	108 (103)	125 (120)	11	20	25	95 (90)	110 (105)	full=46
90	(85)	108 (103)	125 (120)	11	20	25	95 (90)	110 (105)	full=28
90	(85)	108 (103)	125 (120)	11	20	25	95 (90)	110 (105)	full=41
90	(85)	108 (103)	125 (120)	11	20	25	95 (90)	110 (105)	full=31
100		120	140	13,5	35	25	105	122,5	full=31
100		120	140	13,5	35	25	105	122,5	full=36

SHUTON-IPIRANGA advises to use the dimensions of the tables, although it is possible to manufacture ball screw with other dimensions. In brackets () second options.

Smaller nut diameters than the first option of the table can reduce the rigidity of the assembly between 5 and 10%. Please consult SHUTON-IPIRANGA.

High Load IML TS Single nut, DN up to 170.000

Ball screw reference	Number of starts	Nominal diameter (mm)	Lead (mm)	Ball Diameter (mm)	Root diameter (mm)	Circuits	Dynamic load capacity	Static load capacity	Peak load CO-CO TR-TR 'TS'	Nut length
	$1/2$	d_0	P_h	D_w	d_2	i	C_a [kN]	C_{oa} [kN]	F_{max} [kN]	L_{nstd} [mm]
IML TSB-B 63-12,7-9-4	1	63	12,7	9,525	55,2	4	128,9	309	100	91
IML TSB-B 63-12,7-9-5	1	63	12,7	9,525	55,2	5	157,7	395,1	120	103
IML TSB-B 63-12,7-9-6	1	63	12,7	9,525	55,2	6	178,7	453,8	140	123
IML TSB-B 63-12,7-9-7	1	63	12,7	9,525	55,2	7	206,4	539,8	170	135
IML TSB-B 63-12,7-9-8	1	63	12,7	9,525	55,2	8	231,6	618,1	200	148
IML TSB-B 63-12,7-9-9	1	63	12,7	9,525	55,2	9	258,4	704,1	220	161
IML TSB-B 63-12,7-9-10	1	63	12,7	9,525	55,2	10	284,7	790,2	250	173
IML TSB-B 63-12,7-9-11	1	63	12,7	9,525	55,2	11	303,1	845	270	188
IML TSB-B 63-12,7-9-12	1	63	12,7	9,525	55,2	12	327,9	927,1	290	201
IML TSB-B 63-12,7-9-13	1	63	12,7	9,525	55,2	13	355,1	1021	310	214
IML TSB-B 63-12,7-9-14	1	63	12,7	9,525	55,2	14	379,3	1103,1	340	226
IML TSB-B 63-12,7-9-15	1	63	12,7	9,525	55,2	15	403,2	1185,3	360	239
IML TSB-B 63-12,7-9-16	1	63	12,7	9,525	55,2	16	419,8	1236,1	380	253
IML TSB-B 63-12,7-9-17	1	63	12,7	9,525	55,2	17	446	1330	410	265
IML TSB-B 63-12,7-9-18	1	63	12,7	9,525	55,2	18	468,5	1408,3	420	278
IML TSB-B 63-15-9-2	1	63	15	9,525	55,2	2	72,2	144,6	47	70
IML TSB-B 63-15-9-3	1	63	15	9,525	55,2	3	100,4	226,7	75	85
IML TSB-B 63-15-9-4	1	63	15	9,525	55,2	4	129,8	312,7	100	100
IML TSB-B 63-15-9-5	1	63	15	9,525	55,2	5	157,5	394,8	120	115
IML TSB-B 63-15-9-6	1	63	15	9,525	55,2	6	178,5	453,4	140	137
IML TSB-B 63-15-9-7	1	63	15	9,525	55,2	7	206,2	539,4	170	152
IML TSB-B 63-15-9-8	1	63	15	9,525	55,2	8	233,4	625,4	200	167
IML TSB-B 63-15-9-9	1	63	15	9,525	55,2	9	258,1	703,6	220	182
IML TSB-B 63-15-9-10	1	63	15	9,525	55,2	10	284,4	789,6	240	197
IML TSB-B 63-15-9-11	1	63	15	9,525	55,2	11	302,8	844,3	270	215
IML TSB-B 63-15-9-12	1	63	15	9,525	55,2	12	330,3	938,1	290	230
IML TSB-B 63-15-9-13	1	63	15	9,525	55,2	13	354,7	1020,2	310	245
IML TSB-B 63-15-9-14	1	63	15	9,525	55,2	14	378,9	1102,3	340	260
IML TSB-B 63-15-9-15	1	63	15	9,525	55,2	15	402,8	1184,4	350	270
IML TSB-B 63-16-12-2	1	63	16	12,7	54	2	105,3	192,1	35	75
IML TSB-B 63-16-12-3	1	63	16	12,7	54	3	148	305,9	55	91
IML TSB-B 63-16-12-4	1	63	16	12,7	54	4	192,8	426,8	80	107
IML TSB-B 63-16-12-5	1	63	16	12,7	54	5	236,5	547,7	100	123
IML TSB-B 63-16-12-6	1	63	16	12,7	54	6	277,1	661,5	120	139
IML TSB-B 63-16-12-7	1	63	16	12,7	54	7	318,9	782,4	140	155
IML TSB-B 63-16-12-8	1	63	16	12,7	54	8	346,5	853,6	150	179

- C_a and C_{oa} : Modified static and dynamic load capacities, calculated according to DIN 69051/4 standard and ISO3408/5. See Technical description catalogue.

- Check with SHUTON-IPIRANGA in case higher loads or more adjusted nut dimensions are required.

- Check external maximum axial force in the two senses.

For the indicated leads, in case C_a and C_{oa} requirements is lower, there is possibility of smaller size balls.

Maximum force (Peak load CO-CO and TR-TR) calculated with the flange/nut clamping in opposite position to the main support of the shaft, with same load type (traction or compression) in both nut and shaft. For same-side clamping, so different type of load, contact SHUTON-IPIRANGA as peak load is lower.

Nut dimensions									Grease quantity TS
$D_{1, std}$	$D_{1, min}$	D_4	D_6	D_5	L_7	L_1	L_8	L_9	$Q_{Gr} [cm^3]$
100		120	140	13,5	35	25	105	122,5	full=41
100		120	140	13,5	35	25	105	122,5	full=45
100		120	140	13,5	35	25	105	122,5	full=57
100		120	140	13,5	35	25	105	122,5	full=61
100		120	140	13,5	35	25	105	122,5	full=66
100		120	140	13,5	35	25	105	122,5	full=71
100		120	140	13,5	35	25	105	122,5	full=75
100		120	140	13,5	35	25	105	122,5	full=83
100		120	140	13,5	35	25	105	122,5	full=89
100		120	140	13,5	35	25	105	122,5	full=93
100		120	140	13,5	35	25	105	122,5	full=97
100		120	140	13,5	35	25	105	122,5	full=102
100		120	140	13,5	35	25	105	122,5	full=110
100		120	140	13,5	35	25	105	122,5	full=113
100		120	140	13,5	35	25	105	122,5	full=119
100		120	140	13,5	35	25	105	122,5	full=30
100		120	140	13,5	35	25	105	122,5	full=35
100		120	140	13,5	35	25	105	122,5	full=41
100		120	140	13,5	35	25	105	122,5	full=46
100		120	140	13,5	35	25	105	122,5	full=58
100		120	140	13,5	35	25	105	122,5	full=63
100		120	140	13,5	35	25	105	122,5	full=69
100		120	140	13,5	35	25	105	122,5	full=74
100		120	140	13,5	35	25	105	122,5	full=80
100		120	140	13,5	35	25	105	122,5	full=89
100		120	140	13,5	35	25	105	122,5	full=94
100		120	140	13,5	35	25	105	122,5	full=99
100		120	140	13,5	35	25	105	122,5	full=104
100		120	140	13,5	35	25	105	122,5	full=106
110		130	150	13,5	40	25	115	132,5	full=50
110		130	150	13,5	40	25	115	132,5	full=58
110		130	150	13,5	40	25	115	132,5	full=65
110		130	150	13,5	40	25	115	132,5	full=73
110		130	150	13,5	40	25	115	132,5	full=82
110		130	150	13,5	40	25	115	132,5	full=90
110		130	150	13,5	40	25	115	132,5	full=108

SHUTON-IPIRANGA advises to use the dimensions of the tables, although it is possible to manufacture ball screw with other dimensions. In brackets () second options.

Smaller nut diameters than the first option of the table can reduce the rigidity of the assembly between 5 and 10%. Please consult SHUTON-IPIRANGA.

High Load IML TS Single nut, DN up to 170.000

Ball screw reference	Number of starts	Nominal diameter (mm)	Lead (mm)	Ball Diameter (mm)	Root diameter (mm)	Circuits	Dynamic load capacity	Static load capacity	Peak load CO-CO TR-TR 'TS'	Nut length
	$l/2$	d_0	P_h	D_w	d_2	i	C_a [kN]	C_{oa} [kN]	F_{max} [kN]	$L_{n,std}$ [mm]
IML TSB-B 63-16-12-9	1	63	16	12,7	54	9	385,2	967,4	170	195
IML TSB-B 63-16-12-10	1	63	16	12,7	54	10	427	1095,4	190	211
IML TSB-B 63-16-12-11	1	63	16	12,7	54	11	464,4	1209,2	210	227
IML TSB-B 63-16-12-12	1	63	16	12,7	54	12	501,4	1323,1	220	243
IML TSB-B 63-16-12-13	1	63	16	12,7	54	13	541,5	1451,1	240	259
IML TSB-B 63-16-12-14	1	63	16	12,7	54	14	577,6	1564,9	260	271
IML TSB-B 63-20-12-2	1	63	20	12,7	54	2	105,1	191,7	35	83
IML TSB-B 63-20-12-3	1	63	20	12,7	54	3	147,7	305,4	55	103
IML TSB-B 63-20-12-4	1	63	20	12,7	54	4	192,4	426,1	75	123
IML TSB-B 63-20-12-5	1	63	20	12,7	54	5	236	546,8	100	143
IML TSB-B 63-20-12-6	1	63	20	12,7	54	6	276,6	660,5	120	163
IML TSB-B 63-20-12-7	1	63	20	12,7	54	7	318,3	781,2	130	183
IML TSB-B 63-20-12-8	1	63	20	12,7	54	8	345,8	852,2	150	213
IML TSB-B 63-20-12-9	1	63	20	12,7	54	9	384,4	965,8	170	233
IML TSB-B 63-20-12-10	1	63	20	12,7	54	10	426,1	1093,7	190	253
IML TSB-B 63-20-12-11	1	63	20	12,7	54	11	463,4	1207,3	200	268
IML TSB-B 63-20-15-2	1	63	20	15,875	50	2	136,2	226	85	89
IML TSB-B 63-20-15-3	1	63	20	15,875	50	3	196	372,9	140	109
IML TSB-B 63-20-15-4	1	63	20	15,875	50	4	255,1	519,8	180	129
IML TSB-B 63-20-15-5	1	63	20	15,875	50	5	312,8	666,7	240	149
IML TSB-B 63-20-15-6	1	63	20	15,875	50	6	372,6	824,9	290	169
IML TSB-B 63-20-15-7	1	63	20	15,875	50	7	427,6	971,8	330	189
IML TSB-B 63-20-15-8	1	63	20	15,875	50	8	481,6	1118,7	370	209
IML TSB-B 63-20-15-9	1	63	20	15,875	50	9	534,6	1265,6	400	229
IML TSB-B 63-20-15-10	1	63	20	15,875	50	10	586,9	1412,5	430	249
IML TSB-B 63-20-15-11	1	63	20	15,875	50	11	619,8	1491,6	500	274
IML TSB(2S)-U 63-25-9-2	2	63	25	9,525	55,2	2	111,4	239,9	80	97
IML TSB(2S)-U 63-25-9-3	2	63	25	9,525	55,2	3	154,9	376,1	120	122
IML TSB(2S)-U 63-25-9-4	2	63	25	9,525	55,2	4	200,2	518,7	160	147
IML TSB(2S)-U 63-25-9-5	2	63	25	9,525	55,2	5	244,5	661,4	210	172
IML TSB(2S)-U 63-25-9-6	2	63	25	9,525	55,2	6	286,3	797,5	240	197
IML TSB(2S)-U 63-25-9-7	2	63	25	9,525	55,2	7	328,7	940,2	270	222
IML TSB(2S)-U 63-25-9-8	2	63	25	9,525	55,2	8	368,8	1076,3	300	247
IML TSB-B 63-25-15-2	1	63	25	15,875	50	2	135,8	225,4	85	99
IML TSB-B 63-25-15-3	1	63	25	15,875	50	3	195,4	371,9	140	124
IML TSB-B 63-25-15-4	1	63	25	15,875	50	4	254,3	518,5	180	149

- C_a and C_{oa} : Modified static and dynamic load capacities, calculated according to DIN 69051/4 standard and ISO3408/5. See Technical description catalogue.

- Check with SHUTON-IPIRANGA in case higher loads or more adjusted nut dimensions are required.

- Check external maximum axial force in the two senses.

For the indicated leads, in case C_a and C_{oa} requirements is lower, there is possibility of smaller size balls.

Maximum force (Peak load CO-CO and TR-TR) calculated with the flange/nut clamping in opposite position to the main support of the shaft, with same load type (traction or compression) in both nut and shaft. For same-side clamping, so different type of load, contact SHUTON-IPIRANGA as peak load is lower.

Nut dimensions									Grease quantity TS
$D_{1, std}$	$D_{1, min}$	D_4	D_6	D_5	L_7	L_1	L_8	L_9	$Q_{Gr} [cm^3]$
110		130	150	13,5	40	25	115	132,5	full=117
110		130	150	13,5	40	25	115	132,5	full=124
110		130	150	13,5	40	25	115	132,5	full=133
110		130	150	13,5	40	25	115	132,5	full=142
110		130	150	13,5	40	25	115	132,5	full=150
110		130	150	13,5	40	25	115	132,5	full=154
110		130	150	13,5	40	25	115	132,5	full=51
110		130	150	13,5	40	25	115	132,5	full=60
110		130	150	13,5	40	25	115	132,5	full=69
110		130	150	13,5	40	25	115	132,5	full=79
110		130	150	13,5	40	25	115	132,5	full=90
110		130	150	13,5	40	25	115	132,5	full=101
110		130	150	13,5	40	25	115	132,5	full=121
110		130	150	13,5	40	25	115	132,5	full=132
110		130	150	13,5	40	25	115	132,5	full=141
110		130	150	13,5	40	25	115	132,5	full=147
120		140	160	13,5	45	25	125	142,5	full=81
120		140	160	13,5	45	25	125	142,5	full=94
120		140	160	13,5	45	25	125	142,5	full=108
120		140	160	13,5	45	25	125	142,5	full=121
120		140	160	13,5	45	25	125	142,5	full=133
120		140	160	13,5	45	25	125	142,5	full=149
120		140	160	13,5	45	25	125	142,5	full=164
120		140	160	13,5	45	25	125	142,5	full=181
120		140	160	13,5	45	25	125	142,5	full=200
120		140	160	13,5	45	25	125	142,5	full=213
105	(100)	125 (120)	145 (140)	13,5	20	25	110 (105)	127,5 (122,5)	full=36
105	(100)	125 (120)	145 (140)	13,5	20	25	110 (105)	127,5 (122,5)	full=45
105	(100)	125 (120)	145 (140)	13,5	20	25	110 (105)	127,5 (122,5)	full=55
105	(100)	125 (120)	145 (140)	13,5	20	25	110 (105)	127,5 (122,5)	full=64
105	(100)	125 (120)	145 (140)	13,5	20	25	110 (105)	127,5 (122,5)	full=75
105	(100)	125 (120)	145 (140)	13,5	20	25	110 (105)	127,5 (122,5)	full=85
105	(100)	125 (120)	145 (140)	13,5	20	25	110 (105)	127,5 (122,5)	full=97
120		140	160	13,5	45	25	125	142,5	full=79
120		140	160	13,5	45	25	125	142,5	full=94
120		140	160	13,5	45	25	125	142,5	full=111

SHUTON-IPIRANGA advises to use the dimensions of the tables, although it is possible to manufacture ball screw with other dimensions. In brackets () second options.

Smaller nut diameters than the first option of the table can reduce the rigidity of the assembly between 5 and 10%. Please consult SHUTON-IPIRANGA.

High Load IML TS Single nut, DN up to 170.000

Ball screw reference	Number of starts	Nominal diameter (mm)	Lead (mm)	Ball Diameter (mm)	Root diameter (mm)	Circuits	Dynamic load capacity	Static load capacity	Peak load CO-CO TR-TR 'TS'	Nut length
	$l/2$	d_0	P_h	D_w	d_2	i	C_a [kN]	C_{oa} [kN]	F_{max} [kN]	$L_{n,std}$ [mm]
IML TSB-B 63-25-15-5	1	63	25	15,875	50	5	315,3	676,2	240	174
IML TSB-B 63-25-15-6	1	63	25	15,875	50	6	371,3	822,8	280	199
IML TSB-B 63-25-15-7	1	63	25	15,875	50	7	426,2	969,3	320	224
IML TSB-B 63-25-15-8	1	63	25	15,875	50	8	480	1115,8	360	249
IML TSB(2S)-U 63-30-9-2	2	63	30	9,525	55,2	2	110,9	239,1	75	104
IML TSB(2S)-U 63-30-9-3	2	63	30	9,525	55,2	3	156	381,3	120	134
IML TSB(2S)-U 63-30-9-4	2	63	30	9,525	55,2	4	199,4	517	160	164
IML TSB(2S)-U 63-30-9-5	2	63	30	9,525	55,2	5	243,5	659,2	200	194
IML TSB(2S)-U 63-30-9-6	2	63	30	9,525	55,2	6	286,6	801,4	240	224
IML TSB(2S)-U 63-30-9-7	2	63	30	9,525	55,2	7	327,3	937,1	270	254
IML TSB-B 63-30-15-2	1	63	30	15,875	50	2	135,2	224,7	85	109
IML TSB-B 63-30-15-3	1	63	30	15,875	50	3	194,6	370,8	130	139
IML TSB-B 63-30-15-4	1	63	30	15,875	50	4	256,9	528,1	180	169
IML TSB-B 63-30-15-5	1	63	30	15,875	50	5	314	674,1	230	199
IML TSB-B 63-30-15-6	1	63	30	15,875	50	6	369,8	820,2	280	229
IML TSB-B 63-30-15-7	1	63	30	15,875	50	7	424,4	966,3	310	259
IML TSB(2S)-B 63-32-12-2	2	63	32	12,7	54	2	161,6	317,4	55	109
IML TSB(2S)-B 63-32-12-3	2	63	32	12,7	54	3	230,6	517,2	95	141
IML TSB(2S)-B 63-32-12-4	2	63	32	12,7	54	4	299,1	717	130	173
IML TSB(2S)-B 63-32-12-5	2	63	32	12,7	54	5	362,9	905,1	160	205
IML TSB(2S)-B 63-32-12-6	2	63	32	12,7	54	6	428,3	1104,9	190	237
IML TSB(2S)-B 63-32-12-7	2	63	32	12,7	54	7	471,4	1222,5	210	276
IML TSB(2S)-U 63-40-12-2	2	63	40	12,7	54	2	160,3	315,4	55	127
IML TSB(2S)-U 63-40-12-3	2	63	40	12,7	54	3	228,8	513,9	95	167
IML TSB(2S)-U 63-40-12-4	2	63	40	12,7	54	4	296,7	712,5	130	207
IML TSB(2S)-U 63-40-12-5	2	63	40	12,7	54	5	363	911,1	160	247
IML TSB(2S)-U 63-40-12-6	2	63	40	12,7	54	6	427,8	1109,6	180	287
IML TSB(2S)-B 63-40-15-2	2	63	40	15,875	50	2	207,7	371,6	140	131
IML TSB(2S)-B 63-40-15-3	2	63	40	15,875	50	3	304,8	631,7	230	171
IML TSB(2S)-B 63-40-15-4	2	63	40	15,875	50	4	394,6	873,2	300	211
IML TSB(2S)-B 63-40-15-5	2	63	40	15,875	50	5	482,3	1114,8	380	251
IML TSB(2S)-U 63-50-12-2	2	63	50	12,7	54	2	162,2	323,9	55	137
IML TSB(2S)-U 63-50-12-3	2	63	50	12,7	54	3	229,3	520,5	90	187
IML TSB(2S)-U 63-50-12-4	2	63	50	12,7	54	4	296,2	717,2	120	237
IML TSB(2S)-U 63-50-12-5	2	63	50	12,7	54	5	361,5	913,8	150	287
IML TSB(2S)-B 63-50-15-2	2	63	50	15,875	50	2	205	367,9	130	149

- C_a and C_{oa} : Modified static and dynamic load capacities, calculated according to DIN 69051/4 standard and ISO3408/5. See Technical description catalogue.

- Check with SHUTON-IPIRANGA in case higher loads or more adjusted nut dimensions are required.

- Check external maximum axial force in the two senses.

For the indicated leads, in case C_a and C_{oa} requirements is lower, there is possibility of smaller size balls.

Maximum force (Peak load CO-CO and TR-TR) calculated with the flange/nut clamping in opposite position to the main support of the shaft, with same load type (traction or compression) in both nut and shaft. For same-side clamping, so different type of load, contact SHUTON-IPIRANGA as peak load is lower.

Nut dimensions									Grease quantity TS
$D_{1, std}$	$D_{1, min}$	D_4	D_6	D_5	L_7	L_1	L_8	L_9	$Q_{Gr} [cm^3]$
120		140	160	13,5	45	25	125	142,5	full=124
120		140	160	13,5	45	25	125	142,5	full=141
120		140	160	13,5	45	25	125	142,5	full=158
120		140	160	13,5	45	25	125	142,5	full=176
105	(100)	125 (120)	145 (140)	13,5	20	25	110 (105)	127,5 (122,5)	full=36
105	(100)	125 (120)	145 (140)	13,5	20	25	110 (105)	127,5 (122,5)	full=47
105	(100)	125 (120)	145 (140)	13,5	20	25	110 (105)	127,5 (122,5)	full=58
105	(100)	125 (120)	145 (140)	13,5	20	25	110 (105)	127,5 (122,5)	full=68
105	(100)	125 (120)	145 (140)	13,5	20	25	110 (105)	127,5 (122,5)	full=80
105	(100)	125 (120)	145 (140)	13,5	20	25	110 (105)	127,5 (122,5)	full=93
120		140	160	13,5	45	25	125	142,5	full=79
120		140	160	13,5	45	25	125	142,5	full=97
120		140	160	13,5	45	25	125	142,5	full=114
120		140	160	13,5	45	25	125	142,5	full=131
120		140	160	13,5	45	25	125	142,5	full=150
120		140	160	13,5	45	25	125	142,5	full=170
110		130	150	13,5	40	25	115	132,5	full=70
110		130	150	13,5	40	25	115	132,5	full=84
110		130	150	13,5	40	25	115	132,5	full=98
110		130	150	13,5	40	25	115	132,5	full=115
110		130	150	13,5	40	25	115	132,5	full=133
110		130	150	13,5	40	25	115	132,5	full=162
110		130	150	13,5	25	25	115	132,5	full=50
110		130	150	13,5	25	25	115	132,5	full=68
110		130	150	13,5	25	25	115	132,5	full=86
110		130	150	13,5	25	25	115	132,5	full=106
110		130	150	13,5	25	25	115	132,5	full=127
120		140	160	13,5	45	25	125	142,5	full=115
120		140	160	13,5	45	25	125	142,5	full=138
120		140	160	13,5	45	25	125	142,5	full=167
120		140	160	13,5	45	25	125	142,5	full=193
110		130	150	13,5	25	25	115	132,5	full=54
110		130	150	13,5	25	25	115	132,5	full=78
110		130	150	13,5	25	25	115	132,5	full=101
110		130	150	13,5	25	25	115	132,5	full=126
120		140	160	13,5	45	25	125	142,5	full=118

SHUTON-IPIRANGA advises to use the dimensions of the tables, although it is possible to manufacture ball screw with other dimensions. In brackets () second options.

Smaller nut diameters than the first option of the table can reduce the rigidity of the assembly between 5 and 10%. Please consult SHUTON-IPIRANGA.

High Load IML TS Single nut, DN up to 170.000

Ball screw reference	Number of starts	Nominal diameter (mm)	Lead (mm)	Ball Diameter (mm)	Root diameter (mm)	Circuits	Dynamic load capacity	Static load capacity	Peak load CO-CO TR-TR 'TS'	Nut length
	$l/2$	d_0	P_h	D_w	d_2	i	C_a [kN]	C_{oa} [kN]	F_{max} [kN]	L_{nstd} [mm]
IML TSB(2S)-B 63-50-15-3	2	63	50	15,875	50	3	300,9	625,5	220	199
IML TSB(2S)-B 63-50-15-4	2	63	50	15,875	50	4	389,5	864,6	290	249
IML TSB-B 70-12,7-9-2	1	70	12,7	9,525	62,2	2	75,9	161,3	55	65
IML TSB-B 70-12,7-9-3	1	70	12,7	9,525	62,2	3	106,3	255,8	85	78
IML TSB-B 70-12,7-9-4	1	70	12,7	9,525	62,2	4	136,7	350,2	110	91
IML TSB-B 70-12,7-9-5	1	70	12,7	9,525	62,2	5	159,5	417,1	140	110
IML TSB-B 70-12,7-9-6	1	70	12,7	9,525	62,2	6	188,9	511,5	160	123
IML TSB-B 70-12,7-9-7	1	70	12,7	9,525	62,2	7	217,6	605,9	190	135
IML TSB-B 70-12,7-9-8	1	70	12,7	9,525	62,2	8	245,7	700,4	220	148
IML TSB-B 70-12,7-9-9	1	70	12,7	9,525	62,2	9	267	767,3	250	163
IML TSB-B 70-12,7-9-10	1	70	12,7	9,525	62,2	10	294,3	861,7	270	175
IML TSB-B 70-12,7-9-11	1	70	12,7	9,525	62,2	11	321,3	956,1	300	188
IML TSB-B 70-12,7-9-12	1	70	12,7	9,525	62,2	12	347,8	1050,6	330	201
IML TSB-B 70-12,7-9-13	1	70	12,7	9,525	62,2	13	368	1117,5	350	215
IML TSB-B 70-12,7-9-14	1	70	12,7	9,525	62,2	14	394,1	1211,9	380	227
IML TSB-B 70-12,7-9-15	1	70	12,7	9,525	62,2	15	419,8	1306,3	400	240
IML TSB-B 70-12,7-9-16	1	70	12,7	9,525	62,2	16	445,3	1400,8	430	253
IML TSB-B 70-15-9-2	1	70	15	9,525	62,2	2	75,8	161,2	55	70
IML TSB-B 70-15-9-3	1	70	15	9,525	62,2	3	106,2	255,6	85	85
IML TSB-B 70-15-9-4	1	70	15	9,525	62,2	4	136,6	350	110	100
IML TSB-B 70-15-9-5	1	70	15	9,525	62,2	5	159,4	416,8	140	122
IML TSB-B 70-15-9-6	1	70	15	9,525	62,2	6	188,7	511,2	160	137
IML TSB-B 70-15-9-7	1	70	15	9,525	62,2	7	217,4	605,6	190	152
IML TSB-B 70-15-9-8	1	70	15	9,525	62,2	8	245,5	699,9	220	167
IML TSB-B 70-15-9-9	1	70	15	9,525	62,2	9	266,8	766,8	240	185
IML TSB-B 70-15-9-10	1	70	15	9,525	62,2	10	294,1	861,2	270	200
IML TSB-B 70-15-9-11	1	70	15	9,525	62,2	11	321	955,5	300	215
IML TSB-B 70-15-9-12	1	70	15	9,525	62,2	12	347,5	1049,9	330	230
IML TSB-B 70-15-9-13	1	70	15	9,525	62,2	13	367,7	1116,8	350	246
IML TSB-B 70-15-9-14	1	70	15	9,525	62,2	14	393,7	1211,1	370	261
IML TSB-B 70-15-9-15	1	70	15	9,525	62,2	15	419,5	1305,5	390	276
IML TSB-B 70-16-12-2	1	70	16	12,7	61	2	111,3	215	40	75
IML TSB-B 70-16-12-3	1	70	16	12,7	61	3	159,1	351,1	65	91
IML TSB-B 70-16-12-4	1	70	16	12,7	61	4	204,4	480,1	85	107
IML TSB-B 70-16-12-5	1	70	16	12,7	61	5	248,9	609,1	110	123
IML TSB-B 70-16-12-6	1	70	16	12,7	61	6	294,2	745,2	130	139

- C_a and C_{oa} : Modified static and dynamic load capacities, calculated according to DIN 69051/4 standard and ISO3408/5. See Technical description catalogue.

- Check with SHUTON-IPIRANGA in case higher loads or more adjusted nut dimensions are required.

- Check external maximum axial force in the two senses.

For the indicated leads, in case C_a and C_{oa} requirements is lower, there is possibility of smaller size balls.

Maximum force (Peak load CO-CO and TR-TR) calculated with the flange/nut clamping in opposite position to the main support of the shaft, with same load type (traction or compression) in both nut and shaft. For same-side clamping, so different type of load, contact SHUTON-IPIRANGA as peak load is lower.

Nut dimensions									Grease quantity TS
$D_{1, std}$	$D_{1, min}$	D_4	D_6	D_5	L_7	L_1	L_8	L_9	$Q_{Gr} [cm^3]$
120		140	160	13,5	45	25	125	142,5	full=147
120		140	160	13,5	45	25	125	142,5	full=180
110		130	150	13,5	35	25	115	132,5	full=34
110		130	150	13,5	35	25	115	132,5	full=39
110		130	150	13,5	35	25	115	132,5	full=44
110		130	150	13,5	35	25	115	132,5	full=57
110		130	150	13,5	35	25	115	132,5	full=62
110		130	150	13,5	35	25	115	132,5	full=67
110		130	150	13,5	35	25	115	132,5	full=72
110		130	150	13,5	35	25	115	132,5	full=81
110		130	150	13,5	35	25	115	132,5	full=86
110		130	150	13,5	35	25	115	132,5	full=91
110		130	150	13,5	35	25	115	132,5	full=96
110		130	150	13,5	35	25	115	132,5	full=105
110		130	150	13,5	35	25	115	132,5	full=109
110		130	150	13,5	35	25	115	132,5	full=115
110		130	150	13,5	35	25	115	132,5	full=119
110		130	150	13,5	35	25	115	132,5	full=33
110		130	150	13,5	35	25	115	132,5	full=39
110		130	150	13,5	35	25	115	132,5	full=45
110		130	150	13,5	35	25	115	132,5	full=58
110		130	150	13,5	35	25	115	132,5	full=64
110		130	150	13,5	35	25	115	132,5	full=70
110		130	150	13,5	35	25	115	132,5	full=75
110		130	150	13,5	35	25	115	132,5	full=85
110		130	150	13,5	35	25	115	132,5	full=91
110		130	150	13,5	35	25	115	132,5	full=97
110		130	150	13,5	35	25	115	132,5	full=103
110		130	150	13,5	35	25	115	132,5	full=111
110		130	150	13,5	35	25	115	132,5	full=117
110		130	150	13,5	35	25	115	132,5	full=123
120		140	160	13,5	40	25	125	142,5	full=55
120		140	160	13,5	40	25	125	142,5	full=63
120		140	160	13,5	40	25	125	142,5	full=72
120		140	160	13,5	40	25	125	142,5	full=81
120		140	160	13,5	40	25	125	142,5	full=90

SHUTON-IPIRANGA advises to use the dimensions of the tables, although it is possible to manufacture ball screw with other dimensions. In brackets () second options.

Smaller nut diameters than the first option of the table can reduce the rigidity of the assembly between 5 and 10%. Please consult SHUTON-IPIRANGA.

High Load IML TS Single nut, DN up to 170.000

Ball screw reference	Number of starts	Nominal diameter (mm)	Lead (mm)	Ball Diameter (mm)	Root diameter (mm)	Circuits	Dynamic load capacity	Static load capacity	Peak load CO-CO TR-TR 'TS'	Nut length
	$l/2$	d_0	P_h	D_w	d_2	i	C_a [kN]	C_{oa} [kN]	F_{max} [kN]	$L_{n,std}$ [mm]
IML TSB-B 70-16-12-7	1	70	16	12,7	61	7	336,7	874,2	150	155
IML TSB-B 70-16-12-8	1	70	16	12,7	61	8	367,5	960,2	170	179
IML TSB-B 70-16-12-9	1	70	16	12,7	61	9	408,7	1089,2	190	195
IML TSB-B 70-16-12-10	1	70	16	12,7	61	10	449,3	1218,2	210	211
IML TSB-B 70-16-12-11	1	70	16	12,7	61	11	489,3	1347,1	230	227
IML TSB-B 70-16-12-12	1	70	16	12,7	61	12	532,2	1490,4	250	243
IML TSB-B 70-16-12-13	1	70	16	12,7	61	13	571,2	1619,4	270	255
IML TSB-B 70-16-12-14	1	70	16	12,7	61	14	609,7	1748,4	290	271
IML TSB-B 70-20-12-2	1	70	20	12,7	61	2	111,1	214,7	39	83
IML TSB-B 70-20-12-3	1	70	20	12,7	61	3	158,8	350,7	65	103
IML TSB-B 70-20-12-4	1	70	20	12,7	61	4	204,1	479,5	85	123
IML TSB-B 70-20-12-5	1	70	20	12,7	61	5	248,4	608,3	110	143
IML TSB-B 70-20-12-6	1	70	20	12,7	61	6	293,7	744,2	130	163
IML TSB-B 70-20-12-7	1	70	20	12,7	61	7	336,1	873	150	183
IML TSB-B 70-20-12-8	1	70	20	12,7	61	8	366,8	958,9	170	213
IML TSB-B 70-20-12-9	1	70	20	12,7	61	9	408	1087,7	190	233
IML TSB-B 70-20-12-10	1	70	20	12,7	61	10	448,5	1216,5	210	253
IML TSB-B 70-20-12-11	1	70	20	12,7	61	11	491,9	1359,7	230	273
IML TSB-B 70-20-15-2	1	70	20	15,875	57	2	148,5	262,5	95	89
IML TSB-B 70-20-15-3	1	70	20	15,875	57	3	210,1	422,3	150	109
IML TSB-B 70-20-15-4	1	70	20	15,875	57	4	275	593,5	210	129
IML TSB-B 70-20-15-5	1	70	20	15,875	57	5	334,8	753,3	260	149
IML TSB-B 70-20-15-6	1	70	20	15,875	57	6	396,6	924,5	320	169
IML TSB-B 70-20-15-7	1	70	20	15,875	57	7	453,8	1084,3	360	189
IML TSB-B 70-20-15-8	1	70	20	15,875	57	8	513,1	1255,5	410	209
IML TSB-B 70-20-15-9	1	70	20	15,875	57	9	568,3	1415,3	450	229
IML TSB-B 70-20-15-10	1	70	20	15,875	57	10	604,5	1506,6	510	259
IML TSB-B 70-20-15-11	1	70	20	15,875	57	11	664,4	1689,2	560	274
IML TSB(2S)-U 70-25-9-2	2	70	25	9,525	62,2	2	117	267,7	90	97
IML TSB(2S)-U 70-25-9-3	2	70	25	9,525	62,2	3	164	424,3	140	122
IML TSB(2S)-U 70-25-9-4	2	70	25	9,525	62,2	4	210,9	581	180	147
IML TSB(2S)-U 70-25-9-5	2	70	25	9,525	62,2	5	256,8	737,7	230	172
IML TSB(2S)-U 70-25-9-6	2	70	25	9,525	62,2	6	301,7	894,4	270	197
IML TSB(2S)-U 70-25-9-7	2	70	25	9,525	62,2	7	345,7	1051,1	310	222
IML TSB-B 70-25-15-2	1	70	25	15,875	57	2	148,1	262	95	99
IML TSB-B 70-25-15-3	1	70	25	15,875	57	3	209,5	421,4	150	124

- C_a and C_{oa} : Modified static and dynamic load capacities, calculated according to DIN 69051/4 standard and ISO3408/5. See Technical description catalogue.

- Check with SHUTON-IPIRANGA in case higher loads or more adjusted nut dimensions are required.

- Check external maximum axial force in the two senses.

For the indicated leads, in case C_a and C_{oa} requirements is lower, there is possibility of smaller size balls.

Maximum force (Peak load CO-CO and TR-TR) calculated with the flange/nut clamping in opposite position to the main support of the shaft, with same load type (traction or compression) in both nut and shaft. For same-side clamping, so different type of load, contact SHUTON-IPIRANGA as peak load is lower.

Nut dimensions									Grease quantity TS
$D_{1, std}$	$D_{1, min}$	D_4	D_6	D_5	L_7	L_1	L_8	L_9	$Q_{Gr} [cm^3]$
120		140	160	13,5	40	25	125	142,5	full=100
120		140	160	13,5	40	25	125	142,5	full=119
120		140	160	13,5	40	25	125	142,5	full=128
120		140	160	13,5	40	25	125	142,5	full=137
120		140	160	13,5	40	25	125	142,5	full=148
120		140	160	13,5	40	25	125	142,5	full=155
120		140	160	13,5	40	25	125	142,5	full=160
120		140	160	13,5	40	25	125	142,5	full=171
120		140	160	13,5	40	25	125	142,5	full=56
120		140	160	13,5	40	25	125	142,5	full=65
120		140	160	13,5	40	25	125	142,5	full=76
120		140	160	13,5	40	25	125	142,5	full=88
120		140	160	13,5	40	25	125	142,5	full=99
120		140	160	13,5	40	25	125	142,5	full=111
120		140	160	13,5	40	25	125	142,5	full=134
120		140	160	13,5	40	25	125	142,5	full=145
120		140	160	13,5	40	25	125	142,5	full=156
120		140	160	13,5	40	25	125	142,5	full=167
130		150	170	13,5	45	25	135	152,5	full=88
130		150	170	13,5	45	25	135	152,5	full=104
130		150	170	13,5	45	25	135	152,5	full=117
130		150	170	13,5	45	25	135	152,5	full=133
130		150	170	13,5	45	25	135	152,5	full=147
130		150	170	13,5	45	25	135	152,5	full=165
130		150	170	13,5	45	25	135	152,5	full=180
130		150	170	13,5	45	25	135	152,5	full=200
130		150	170	13,5	45	25	135	152,5	full=228
130		153	176	15,5	45	25	135	155,5	full=233
110		130	150	13,5	25	25	115	132,5	full=40
110		130	150	13,5	25	25	115	132,5	full=51
110		130	150	13,5	25	25	115	132,5	full=61
110		130	150	13,5	25	25	115	132,5	full=72
110		130	150	13,5	25	25	115	132,5	full=83
110		130	150	13,5	25	25	115	132,5	full=95
130		150	170	13,5	45	25	135	152,5	full=86
130		150	170	13,5	45	25	135	152,5	full=104

SHUTON-IPIRANGA advises to use the dimensions of the tables, although it is possible to manufacture ball screw with other dimensions. In brackets () second options.

Smaller nut diameters than the first option of the table can reduce the rigidity of the assembly between 5 and 10%. Please consult SHUTON-IPIRANGA.

High Load IML TS Single nut, DN up to 170.000

Ball screw reference	Number of starts	Nominal diameter (mm)	Lead (mm)	Ball Diameter (mm)	Root diameter (mm)	Circuits	Dynamic load capacity	Static load capacity	Peak load CO-CO TR-TR 'TS'	Nut length
	$l/2$	d_0	P_h	D_w	d_2	i	C_a [kN]	C_{oa} [kN]	F_{max} [kN]	$L_{n,std}$ [mm]
IML TSB-B 70-25-15-4	1	70	25	15,875	57	4	274,2	592,3	210	149
IML TSB-B 70-25-15-5	1	70	25	15,875	57	5	333,9	751,7	260	174
IML TSB-B 70-25-15-6	1	70	25	15,875	57	6	395,5	922,6	310	199
IML TSB-B 70-25-15-7	1	70	25	15,875	57	7	455,8	1093,4	360	224
IML TSB-B 70-25-15-8	1	70	25	15,875	57	8	511,7	1252,9	400	249
IML TSB(2S)-U 70-30-9-2	2	70	30	9,525	62,2	2	116,6	267	90	103
IML TSB(2S)-U 70-30-9-3	2	70	30	9,525	62,2	3	163,4	423,2	140	133
IML TSB(2S)-U 70-30-9-4	2	70	30	9,525	62,2	4	210,1	579,5	180	163
IML TSB(2S)-U 70-30-9-5	2	70	30	9,525	62,2	5	255,9	735,8	230	193
IML TSB(2S)-U 70-30-9-6	2	70	30	9,525	62,2	6	300,7	892	270	223
IML TSB(2S)-U 70-30-9-7	2	70	30	9,525	62,2	7	344,5	1048,3	300	253
IML TSB-B 70-30-15-2	1	70	30	15,875	57	2	147,6	261,3	95	109
IML TSB-B 70-30-15-3	1	70	30	15,875	57	3	208,8	420,3	150	139
IML TSB-B 70-30-15-4	1	70	30	15,875	57	4	273,3	590,8	210	169
IML TSB-B 70-30-15-5	1	70	30	15,875	57	5	336,2	761,2	260	199
IML TSB-B 70-30-15-6	1	70	30	15,875	57	6	394,2	920,2	310	229
IML TSB-B 70-30-15-7	1	70	30	15,875	57	7	454,2	1090,6	350	259
IML TSB(2S)-B 70-32-12-2	2	70	32	12,7	61	2	171,1	355,8	65	109
IML TSB(2S)-B 70-32-12-3	2	70	32	12,7	61	3	244,6	581,1	110	141
IML TSB(2S)-B 70-32-12-4	2	70	32	12,7	61	4	314,3	794,6	140	173
IML TSB(2S)-B 70-32-12-5	2	70	32	12,7	61	5	385,6	1019,9	180	205
IML TSB(2S)-B 70-32-12-6	2	70	32	12,7	61	6	452,3	1233,3	210	237
IML TSB(2S)-B 70-32-12-7	2	70	32	12,7	61	7	500,5	1375,7	240	276
IML TSB(2S)-U 70-40-12-2	2	70	40	12,7	61	2	173,8	365,7	65	126
IML TSB(2S)-U 70-40-12-3	2	70	40	12,7	61	3	243	578,1	100	166
IML TSB(2S)-U 70-40-12-4	2	70	40	12,7	61	4	315,3	802,2	140	206
IML TSB(2S)-U 70-40-12-5	2	70	40	12,7	61	5	383	1014,6	170	246
IML TSB(2S)-B 70-40-15-2	2	70	40	15,875	57	2	227,1	432,7	160	131
IML TSB(2S)-B 70-40-15-3	2	70	40	15,875	57	3	327,1	714,9	250	171
IML TSB(2S)-B 70-40-15-4	2	70	40	15,875	57	4	420,6	978,2	340	211
IML TSB(2S)-B 70-40-15-5	2	70	40	15,875	57	5	517,2	1260,4	420	251
IML TSB(2S)-U 70-50-12-2	2	70	50	12,7	61	2	172	362,8	65	136
IML TSB(2S)-U 70-50-12-3	2	70	50	12,7	61	3	243,7	585,2	100	186
IML TSB(2S)-U 70-50-12-4	2	70	50	12,7	61	4	312	795,8	140	236
IML TSB(2S)-U 70-50-15-2	2	70	50	15,875	57	2	224,7	429,2	150	145
IML TSB(2S)-U 70-50-15-3	2	70	50	15,875	57	3	323,6	709	240	195

- C_a and C_{oa} : Modified static and dynamic load capacities, calculated according to DIN 69051/4 standard and ISO3408/5. See Technical description catalogue.

- Check with SHUTON-IPIRANGA in case higher loads or more adjusted nut dimensions are required.

- Check external maximum axial force in the two senses.

For the indicated leads, in case C_a and C_{oa} requirements is lower, there is possibility of smaller size balls.

Maximum force (Peak load CO-CO and TR-TR) calculated with the flange/nut clamping in opposite position to the main support of the shaft, with same load type (traction or compression) in both nut and shaft. For same-side clamping, so different type of load, contact SHUTON-IPIRANGA as peak load is lower.

Nut dimensions									Grease quantity TS
$D_{1, std}$	$D_{1, min}$	D_4	D_6	D_5	L_7	L_1	L_8	L_9	$Q_{Gr} [cm^3]$
130		150	170	13,5	45	25	135	152,5	full=120
130		150	170	13,5	45	25	135	152,5	full=138
130		150	170	13,5	45	25	135	152,5	full=155
130		150	170	13,5	45	25	135	152,5	full=174
130		150	170	13,5	45	25	135	152,5	full=193
110		130	150	13,5	25	25	115	132,5	full=40
110		130	150	13,5	25	25	115	132,5	full=52
110		130	150	13,5	25	25	115	132,5	full=63
110		130	150	13,5	25	25	115	132,5	full=76
110		130	150	13,5	25	25	115	132,5	full=89
110		130	150	13,5	25	25	115	132,5	full=102
130		150	170	13,5	45	25	135	152,5	full=86
130		150	170	13,5	45	25	135	152,5	full=107
130		150	170	13,5	45	25	135	152,5	full=125
130		150	170	13,5	45	25	135	152,5	full=145
130		150	170	13,5	45	25	135	152,5	full=166
130		150	170	13,5	45	25	135	152,5	full=186
120		140	160	13,5	40	25	125	142,5	full=76
120		140	160	13,5	40	25	125	142,5	full=92
120		140	160	13,5	40	25	125	142,5	full=110
120		140	160	13,5	40	25	125	142,5	full=126
120		140	160	13,5	40	25	125	142,5	full=146
120		140	160	13,5	40	25	125	142,5	full=176
120		140	160	13,5	25	25	125	142,5	full=54
120		140	160	13,5	25	25	125	142,5	full=75
120		140	160	13,5	25	25	125	142,5	full=96
120		140	160	13,5	25	25	125	142,5	full=119
130		150	170	13,5	45	25	135	152,5	full=124
130		150	170	13,5	45	25	135	152,5	full=153
130		150	170	13,5	45	25	135	152,5	full=183
130		150	170	13,5	45	25	135	152,5	full=212
120		140	160	13,5	25	25	125	142,5	full=60
120		140	160	13,5	25	25	125	142,5	full=86
120		140	160	13,5	25	25	125	142,5	full=114
130		150	170	13,5	30	25	135	152,5	full=83
130		150	170	13,5	30	25	135	152,5	full=118

SHUTON-IPIRANGA advises to use the dimensions of the tables, although it is possible to manufacture ball screw with other dimensions. In brackets () second options.

Smaller nut diameters than the first option of the table can reduce the rigidity of the assembly between 5 and 10%. Please consult SHUTON-IPIRANGA.

High Load IML TS Single nut, DN up to 170.000

Ball screw reference	Number of starts	Nominal diameter (mm)	Lead (mm)	Ball Diameter (mm)	Root diameter (mm)	Circuits	Dynamic load capacity	Static load capacity	Peak load CO-CO TR-TR 'TS'	Nut length
	$l/2$	d_0	P_h	D_w	d_2	i	C_a [kN]	C_{oa} [kN]	F_{max} [kN]	L_{nstd} [mm]
IML TSB(2S)-U 70-50-15-4	2	70	50	15,875	57	4	421,4	988,9	330	245
IML TSB-B 80-12,7-9-8	1	80	12,7	9,525	72,2	8	261,5	807,9	260	148
IML TSB-B 80-12,7-9-9	1	80	12,7	9,525	72,2	9	285,4	891,1	280	163
IML TSB-B 80-12,7-9-10	1	80	12,7	9,525	72,2	10	314,1	998	310	175
IML TSB-B 80-12,7-9-11	1	80	12,7	9,525	72,2	11	342,3	1104,9	350	188
IML TSB-B 80-12,7-9-12	1	80	12,7	9,525	72,2	12	370,2	1211,8	380	201
IML TSB-B 80-12,7-9-13	1	80	12,7	9,525	72,2	13	393,7	1299	410	215
IML TSB-B 80-12,7-9-14	1	80	12,7	9,525	72,2	14	418,6	1394	430	227
IML TSB-B 80-12,7-9-15	1	80	12,7	9,525	72,2	15	446,4	1504,9	460	240
IML TSB-B 80-12,7-9-16	1	80	12,7	9,525	72,2	16	473,9	1615,8	490	253
IML TSB-B 80-15-9-8	1	80	15	9,525	72,2	8	261,3	807,5	260	167
IML TSB-B 80-15-9-9	1	80	15	9,525	72,2	9	285,3	890,6	280	185
IML TSB-B 80-15-9-10	1	80	15	9,525	72,2	10	313,9	997,5	310	200
IML TSB-B 80-15-9-11	1	80	15	9,525	72,2	11	342,1	1104,4	340	215
IML TSB-B 80-15-9-12	1	80	15	9,525	72,2	12	369,9	1211,3	370	230
IML TSB-B 80-15-9-13	1	80	15	9,525	72,2	13	393,5	1298,4	400	246
IML TSB-B 80-15-9-14	1	80	15	9,525	72,2	14	418,3	1393,4	430	261
IML TSB-B 80-15-9-15	1	80	15	9,525	72,2	15	446,1	1504,2	450	276
IML TSB-B 80-15-9-16	1	80	15	9,525	72,2	16	473,6	1615	480	291
IML TSB-B 80-16-12-2	1	80	16	12,7	71	2	120,6	252,9	46	75
IML TSB-B 80-16-12-3	1	80	16	12,7	71	3	170	404,6	75	91
IML TSB-B 80-16-12-4	1	80	16	12,7	71	4	219,3	556,3	100	107
IML TSB-B 80-16-12-5	1	80	16	12,7	71	5	267,5	708	130	123
IML TSB-B 80-16-12-6	1	80	16	12,7	71	6	312,9	852,5	150	139
IML TSB-B 80-16-12-7	1	80	16	12,7	71	7	346,9	953,6	170	163
IML TSB-B 80-16-12-8	1	80	16	12,7	71	8	394,2	1112,6	200	179
IML TSB-B 80-16-12-9	1	80	16	12,7	71	9	437,3	1257,1	220	195
IML TSB-B 80-16-12-10	1	80	16	12,7	71	10	483	1416	250	211
IML TSB-B 80-16-12-11	1	80	16	12,7	71	11	524,8	1560,5	270	227
IML TSB-B 80-16-12-12	1	80	16	12,7	71	12	566	1705	290	243
IML TSB-B 80-16-12-13	1	80	16	12,7	71	13	600,5	1820,6	310	262
IML TSB-B 80-16-12-14	1	80	16	12,7	71	14	642,5	1972,3	330	278
IML TSB-B 80-16-12-15	1	80	16	12,7	71	15	684	2124	360	294
IML TSB-B 80-16-12-16	1	80	16	12,7	71	16	725,2	2275,7	380	310
IML TSB-B 80-16-12-17	1	80	16	12,7	71	17	761,4	2405,8	390	326
IML TSB-B 80-16-12-18	1	80	16	12,7	71	18	801,9	2557,5	410	342

- C_a and C_{oa} : Modified static and dynamic load capacities, calculated according to DIN 69051/4 standard and ISO3408/5. See Technical description catalogue.

- Check with SHUTON-IPIRANGA in case higher loads or more adjusted nut dimensions are required.

- Check external maximum axial force in the two senses.

For the indicated leads, in case C_a and C_{oa} requirements is lower, there is possibility of smaller size balls.

Maximum force (Peak load CO-CO and TR-TR) calculated with the flange/nut clamping in opposite position to the main support of the shaft, with same load type (traction or compression) in both nut and shaft. For same-side clamping, so different type of load, contact SHUTON-IPIRANGA as peak load is lower.

Nut dimensions									Grease quantity TS
$D_{1, std}$	$D_{1, min}$	D_4	D_6	D_5	L_7	L_1	L_8	L_9	$Q_{Gr} [cm^3]$
130		150	170	13,5	30	25	135	152,5	full=150
120		140	160	13,5	35	25	125	142,5	full=82
120		140	160	13,5	35	25	125	142,5	full=92
120		140	160	13,5	35	25	125	142,5	full=97
120		140	160	13,5	35	25	125	142,5	full=103
120		140	160	13,5	35	25	125	142,5	full=109
120		140	160	13,5	35	25	125	142,5	full=117
120		140	160	13,5	35	25	125	142,5	full=124
120		140	160	13,5	35	25	125	142,5	full=130
120		140	160	13,5	35	25	125	142,5	full=135
120		140	160	13,5	35	25	125	142,5	full=86
120		140	160	13,5	35	25	125	142,5	full=97
120		140	160	13,5	35	25	125	142,5	full=103
120		140	160	13,5	35	25	125	142,5	full=110
120		140	160	13,5	35	25	125	142,5	full=116
120		140	160	13,5	35	25	125	142,5	full=125
120		140	160	13,5	35	25	125	142,5	full=133
120		140	160	13,5	35	25	125	142,5	full=140
120		140	160	13,5	35	25	125	142,5	full=146
130		150	170	13,5	40	25	135	152,5	full=62
130		150	170	13,5	40	25	135	152,5	full=71
130		150	170	13,5	40	25	135	152,5	full=81
130		150	170	13,5	40	25	135	152,5	full=91
130		150	170	13,5	40	25	135	152,5	full=102
130		150	170	13,5	40	25	135	152,5	full=126
130		150	170	13,5	40	25	135	152,5	full=134
130		150	170	13,5	40	25	135	152,5	full=145
130		150	170	13,5	40	25	135	152,5	full=154
130		150	170	13,5	40	25	135	152,5	full=165
130		150	170	13,5	40	25	135	152,5	full=176
130		150	170	13,5	40	25	135	152,5	full=189
130		150	170	13,5	40	25	135	152,5	full=199
130		150	170	13,5	40	25	135	152,5	full=209
130		150	170	13,5	40	25	135	152,5	full=220
130		150	170	13,5	40	25	135	152,5	full=232
130		150	170	13,5	40	25	135	152,5	full=242

SHUTON-IPIRANGA advises to use the dimensions of the tables, although it is possible to manufacture ball screw with other dimensions. In brackets () second options.

Smaller nut diameters than the first option of the table can reduce the rigidity of the assembly between 5 and 10%. Please consult SHUTON-IPIRANGA.

High Load IML TS Single nut, DN up to 170.000

Ball screw reference	Number of starts	Nominal diameter (mm)	Lead (mm)	Ball Diameter (mm)	Root diameter (mm)	Circuits	Dynamic load capacity	Static load capacity	Peak load CO-CO TR-TR 'TS'	Nut length
	$l/2$	d_0	P_h	D_w	d_2	i	C_a [kN]	C_{oa} [kN]	F_{max} [kN]	$L_{n,std}$ [mm]
IML TSB-B 80-16-12-19	1	80	16	12,7	71	19	831,5	2658,6	430	357
IML TSB-U 80-20-12-2	1	80	20	12,7	71	2	120,4	252,6	47	98
IML TSB-U 80-20-12-3	1	80	20	12,7	71	3	169,8	404,2	75	118
IML TSB-U 80-20-12-4	1	80	20	12,7	71	4	219	555,7	100	138
IML TSB-U 80-20-12-5	1	80	20	12,7	71	5	267,2	707,3	130	158
IML TSB-U 80-20-12-6	1	80	20	12,7	71	6	314,2	858,8	150	178
IML TSB-U 80-20-12-7	1	80	20	12,7	71	7	358,6	1003,2	170	198
IML TSB-U 80-20-12-8	1	80	20	12,7	71	8	403,8	1154,7	190	218
IML TSB-B 80-20-12-9	1	80	20	12,7	71	9	436,7	1255,8	220	233
IML TSB-B 80-20-12-10	1	80	20	12,7	71	10	482,3	1414,6	240	253
IML TSB-B 80-20-12-11	1	80	20	12,7	71	11	524,1	1558,9	260	273
IML TSB-B 80-20-12-12	1	80	20	12,7	71	12	568,5	1717,7	290	293
IML TSB-B 80-20-12-13	1	80	20	12,7	71	13	599,7	1818,7	300	317
IML TSB-B 80-20-12-14	1	80	20	12,7	71	14	641,6	1970,3	320	337
IML TSB-B 80-20-12-15	1	80	20	12,7	71	15	683,1	2121,8	340	355
IML TSB-B 80-20-12-16	1	80	20	12,7	71	16	724,2	2273,4	360	368
IML TSB-B 80-20-15-2	1	80	20	15,875	67	2	163	311,6	110	89
IML TSB-B 80-20-15-3	1	80	20	15,875	67	3	229	496,3	180	109
IML TSB-B 80-20-15-4	1	80	20	15,875	67	4	298,3	692,5	250	129
IML TSB-B 80-20-15-5	1	80	20	15,875	67	5	362,7	877,1	310	149
IML TSB-B 80-20-15-6	1	80	20	15,875	67	6	428,8	1073,3	370	169
IML TSB-B 80-20-15-7	1	80	20	15,875	67	7	490,5	1258	420	189
IML TSB-B 80-20-15-8	1	80	20	15,875	67	8	536,2	1384,9	480	219
IML TSB-B 80-20-15-9	1	80	20	15,875	67	9	596	1569,6	540	239
IML TSB-B 80-20-15-10	1	80	20	15,875	67	10	654,9	1754,3	590	259
IML TSB-B 80-20-15-11	1	80	20	15,875	67	11	712,9	1938,9	640	279
IML TSB-B 80-20-15-12	1	80	20	15,875	67	12	775,8	2146,7	700	299
IML TSB-B 80-20-15-13	1	80	20	15,875	67	13	832,3	2331,3	740	319
IML TSB-B 80-20-15-14	1	80	20	15,875	67	14	888,3	2516	780	339
IML TSB-B 80-20-15-15	1	80	20	15,875	67	15	927,5	2631,4	830	361
IML TSB(2S)-U 80-25-9-2	2	80	25	9,525	72,2	2	126,5	315,7	100	96
IML TSB(2S)-U 80-25-9-3	2	80	25	9,525	72,2	3	175,5	493,3	160	121
IML TSB(2S)-U 80-25-9-4	2	80	25	9,525	72,2	4	224,7	670,9	210	146
IML TSB(2S)-U 80-25-9-5	2	80	25	9,525	72,2	5	273	848,5	260	171
IML TSB(2S)-U 80-25-9-6	2	80	25	9,525	72,2	6	321,5	1032,7	310	196
IML TSB(2S)-U 80-25-9-7	2	80	25	9,525	72,2	7	367,7	1210,3	360	221

- C_a and C_{oa} : Modified static and dynamic load capacities, calculated according to DIN 69051/4 standard and ISO3408/5. See Technical description catalogue.

- Check with SHUTON-IPIRANGA in case higher loads or more adjusted nut dimensions are required.

- Check external maximum axial force in the two senses.

For the indicated leads, in case C_a and C_{oa} requirements is lower, there is possibility of smaller size balls.

Maximum force (Peak load CO-CO and TR-TR) calculated with the flange/nut clamping in opposite position to the main support of the shaft, with same load type (traction or compression) in both nut and shaft. For same-side clamping, so different type of load, contact SHUTON-IPIRANGA as peak load is lower.

Nut dimensions									Grease quantity TS
$D_{1, std}$	$D_{1, min}$	D_4	D_6	D_5	L_7	L_1	L_8	L_9	$Q_{Gr} [cm^3]$
130		150	170	13,5	40	25	135	152,5	full=251
135	(130)	155 (150)	175 (170)	13,5	25	25	140 (135)	157,5 (152,5)	full=61
135	(130)	155 (150)	175 (170)	13,5	25	25	140 (135)	157,5 (152,5)	full=73
135	(130)	155 (150)	175 (170)	13,5	25	25	140 (135)	157,5 (152,5)	full=85
135	(130)	155 (150)	175 (170)	13,5	25	25	140 (135)	157,5 (152,5)	full=97
135	(130)	155 (150)	175 (170)	13,5	25	25	140 (135)	157,5 (152,5)	full=110
135	(130)	155 (150)	175 (170)	13,5	25	25	140 (135)	157,5 (152,5)	full=124
135	(130)	155 (150)	175 (170)	13,5	25	25	140 (135)	157,5 (152,5)	full=138
130		150	170	13,5	40	25	135	152,5	full=164
130		150	170	13,5	40	25	135	152,5	full=175
130		150	170	13,5	40	25	135	152,5	full=189
130		150	170	13,5	40	25	135	152,5	full=200
130		150	170	13,5	40	25	135	152,5	full=218
130		150	170	13,5	40	25	135	152,5	full=231
130		150	170	13,5	40	25	135	152,5	full=241
130		150	170	13,5	40	25	135	152,5	full=245
140		166	192	17,5	45	25	145	168,5	full=100
140		166	192	17,5	45	25	145	168,5	full=116
140		166	192	17,5	45	25	145	168,5	full=131
140		166	192	17,5	45	25	145	168,5	full=148
140		166	192	17,5	45	25	145	168,5	full=166
140		166	192	17,5	45	25	145	168,5	full=185
140		166	192	17,5	45	25	145	168,5	full=219
140		166	192	17,5	45	25	145	168,5	full=237
140		166	192	17,5	45	25	145	168,5	full=254
140		166	192	17,5	45	25	145	168,5	full=274
140		166	192	17,5	45	25	145	168,5	full=289
140		166	192	17,5	45	25	145	168,5	full=309
140		166	192	17,5	45	25	145	168,5	full=327
140		166	192	17,5	45	25	145	168,5	full=345
125	(120)	145 (140)	165 (160)	13,5	25	25	130 (125)	147,5 (142,5)	full=47
125	(120)	145 (140)	165 (160)	13,5	25	25	130 (125)	147,5 (142,5)	full=58
125	(120)	145 (140)	165 (160)	13,5	25	25	130 (125)	147,5 (142,5)	full=70
125	(120)	145 (140)	165 (160)	13,5	25	25	130 (125)	147,5 (142,5)	full=83
125	(120)	145 (140)	165 (160)	13,5	25	25	130 (125)	147,5 (142,5)	full=95
125	(120)	145 (140)	165 (160)	13,5	25	25	130 (125)	147,5 (142,5)	full=108

SHUTON-IPIRANGA advises to use the dimensions of the tables, although it is possible to manufacture ball screw with other dimensions. In brackets () second options.

Smaller nut diameters than the first option of the table can reduce the rigidity of the assembly between 5 and 10%. Please consult SHUTON-IPIRANGA.

High Load IML TS Single nut, DN up to 170.000

Ball screw reference	Number of starts	Nominal diameter (mm)	Lead (mm)	Ball Diameter (mm)	Root diameter (mm)	Circuits	Dynamic load capacity	Static load capacity	Peak load CO-CO TR-TR 'TS'	Nut length
	$l/2$	d_0	P_h	D_w	d_2	i	C_a [kN]	C_{oa} [kN]	F_{max} [kN]	L_{nstd} [mm]
IML TSB-B 80-25-15-2	1	80	25	15,875	67	2	162,6	311,1	110	99
IML TSB-B 80-25-15-3	1	80	25	15,875	67	3	228,5	495,5	180	124
IML TSB-B 80-25-15-4	1	80	25	15,875	67	4	297,7	691,3	250	149
IML TSB-B 80-25-15-5	1	80	25	15,875	67	5	362	875,7	300	174
IML TSB-B 80-25-15-6	1	80	25	15,875	67	6	427,9	1071,6	360	199
IML TSB-B 80-25-15-7	1	80	25	15,875	67	7	489,4	1255,9	420	224
IML TSB-B 80-25-15-8	1	80	25	15,875	67	8	535	1382,7	470	262
IML TSB-B 80-25-15-9	1	80	25	15,875	67	9	594,7	1567	520	287
IML TSB-B 80-25-15-10	1	80	25	15,875	67	10	653,5	1751,4	570	312
IML TSB-B 80-25-15-11	1	80	25	15,875	67	11	717	1958,8	620	337
IML TSB-B 80-25-15-12	1	80	25	15,875	67	12	774,1	2143,2	660	360
IML TSB-B 80-25-19-2	1	80	25	19,05	64,1	2	194,7	343,5	150	105
IML TSB-B 80-25-19-3	1	80	25	19,05	64,1	3	282,1	572,5	240	130
IML TSB-B 80-25-19-4	1	80	25	19,05	64,1	4	368,2	801,6	320	155
IML TSB-B 80-25-19-5	1	80	25	19,05	64,1	5	452,2	1030,6	420	180
IML TSB-B 80-25-19-6	1	80	25	19,05	64,1	6	534,2	1259,6	490	205
IML TSB-B 80-25-19-7	1	80	25	19,05	64,1	7	609,8	1472,3	560	230
IML TSB-B 80-25-19-8	1	80	25	19,05	64,1	8	688,6	1701,3	630	255
IML TSB-B 80-25-19-9	1	80	25	19,05	64,1	9	739,8	1832,2	700	293
IML TSB-B 80-25-19-10	1	80	25	19,05	64,1	10	816,4	2061,2	780	318
IML TSB-B 80-25-19-11	1	80	25	19,05	64,1	11	891,9	2290,2	850	343
IML TSB-B 80-25-19-12	1	80	25	19,05	64,1	12	966,4	2519,2	900	366
IML TSB(2S)-U 80-30-9-2	2	80	30	9,525	72,2	2	126,1	315,1	100	103
IML TSB(2S)-U 80-30-9-3	2	80	30	9,525	72,2	3	175	492,3	160	133
IML TSB(2S)-U 80-30-9-4	2	80	30	9,525	72,2	4	224,1	669,5	210	163
IML TSB(2S)-U 80-30-9-5	2	80	30	9,525	72,2	5	273,6	853,3	260	193
IML TSB(2S)-U 80-30-9-6	2	80	30	9,525	72,2	6	320,7	1030,6	310	223
IML TSB(2S)-B 80-30-9-7	2	80	30	9,525	72,2	7	358,8	1168,4	350	265
IML TSB(2S)-B 80-30-9-8	2	80	30	9,525	72,2	8	402,9	1339,1	400	295
IML TSB(2S)-B 80-30-9-9	2	80	30	9,525	72,2	9	439,7	1476,9	430	330
IML TSB(2S)-B 80-30-9-10	2	80	30	9,525	72,2	10	483,9	1654,2	470	358
IML TSB-B 80-30-19-2	1	80	30	19,05	64,1	2	194,2	342,9	140	115
IML TSB-B 80-30-19-3	1	80	30	19,05	64,1	3	281,3	571,4	240	145
IML TSB-B 80-30-19-4	1	80	30	19,05	64,1	4	367,3	800	320	175
IML TSB-B 80-30-19-5	1	80	30	19,05	64,1	5	451	1028,6	410	205
IML TSB-B 80-30-19-6	1	80	30	19,05	64,1	6	532,8	1257,1	480	235

- C_a and C_{oa} : Modified static and dynamic load capacities, calculated according to DIN 69051/4 standard and ISO3408/5. See Technical description catalogue.

- Check with SHUTON-IPIRANGA in case higher loads or more adjusted nut dimensions are required.

- Check external maximum axial force in the two senses.

For the indicated leads, in case C_a and C_{oa} requirements is lower, there is possibility of smaller size balls.

Maximum force (Peak load CO-CO and TR-TR) calculated with the flange/nut clamping in opposite position to the main support of the shaft, with same load type (traction or compression) in both nut and shaft. For same-side clamping, so different type of load, contact SHUTON-IPIRANGA as peak load is lower.

Nut dimensions									Grease quantity TS
$D_{1, std}$	$D_{1, min}$	D_4	D_6	D_5	L_7	L_1	L_8	L_9	$Q_{Gr} [cm^3]$
140		166	192	17,5	45	25	145	168,5	full=98
140		166	192	17,5	45	25	145	168,5	full=116
140		166	192	17,5	45	25	145	168,5	full=134
140		166	192	17,5	45	25	145	168,5	full=154
140		166	192	17,5	45	25	145	168,5	full=175
140		166	192	17,5	45	25	145	168,5	full=196
140		166	192	17,5	45	25	145	168,5	full=236
140		166	192	17,5	45	25	145	168,5	full=256
140		166	192	17,5	45	25	145	168,5	full=277
140		166	192	17,5	45	25	145	168,5	full=297
140		166	192	17,5	45	25	145	168,5	full=314
150		176	202	17,5	50	40	155	178,5	full=143
150		176	202	17,5	50	40	155	178,5	full=166
150		176	202	17,5	50	40	155	178,5	full=190
150		176	202	17,5	50	40	155	178,5	full=213
150		176	202	17,5	50	40	155	178,5	full=240
150		176	202	17,5	50	40	155	178,5	full=267
150		176	202	17,5	50	40	155	178,5	full=297
150		176	202	17,5	50	40	155	178,5	full=350
150		176	202	17,5	50	40	155	178,5	full=370
150		176	202	17,5	50	40	155	178,5	full=395
150		176	202	17,5	50	40	155	178,5	full=420
125	(120)	145 (140)	165 (160)	13,5	25	25	130 (125)	147,5 (142,5)	full=47
125	(120)	145 (140)	165 (160)	13,5	25	25	130 (125)	147,5 (142,5)	full=60
125	(120)	145 (140)	165 (160)	13,5	25	25	130 (125)	147,5 (142,5)	full=74
125	(120)	145 (140)	165 (160)	13,5	25	25	130 (125)	147,5 (142,5)	full=88
125	(120)	145 (140)	165 (160)	13,5	25	25	130 (125)	147,5 (142,5)	full=102
120		140	160	13,5	35	25	125	142,5	full=136
120		140	160	13,5	35	25	125	142,5	full=150
120		140	160	13,5	35	25	125	142,5	full=171
120		140	160	13,5	35	25	125	142,5	full=183
150		176	202	17,5	50	40	155	178,5	full=140
150		176	202	17,5	50	40	155	178,5	full=165
150		176	202	17,5	50	40	155	178,5	full=193
150		176	202	17,5	50	40	155	178,5	full=219
150		176	202	17,5	50	40	155	178,5	full=249

SHUTON-IPIRANGA advises to use the dimensions of the tables, although it is possible to manufacture ball screw with other dimensions. In brackets () second options.

Smaller nut diameters than the first option of the table can reduce the rigidity of the assembly between 5 and 10%. Please consult SHUTON-IPIRANGA.

High Load IML TS Single nut, DN up to 170.000

Ball screw reference	Number of starts	Nominal diameter (mm)	Lead (mm)	Ball Diameter (mm)	Root diameter (mm)	Circuits	Dynamic load capacity	Static load capacity	Peak load CO-CO TR-TR 'TS'	Nut length
	$l/2$	d_0	P_h	D_w	d_2	i	C_a [kN]	C_{oa} [kN]	F_{max} [kN]	$L_{n,std}$ [mm]
IML TSB-B 80-30-19-7	1	80	30	19,05	64,1	7	612,8	1485,7	560	265
IML TSB-B 80-30-19-8	1	80	30	19,05	64,1	8	660,1	1600	610	310
IML TSB-B 80-30-19-9	1	80	30	19,05	64,1	9	737,9	1828,5	680	340
IML TSB-B 80-30-19-10	1	80	30	19,05	64,1	10	814,3	2057,1	750	361
IML TSB(2S)-U 80-32-12-2	2	80	32	12,7	71	2	185,8	419,1	80	116
IML TSB(2S)-U 80-32-12-3	2	80	32	12,7	71	3	262	670,6	120	148
IML TSB(2S)-U 80-32-12-4	2	80	32	12,7	71	4	337,9	922,1	160	180
IML TSB(2S)-U 80-32-12-5	2	80	32	12,7	71	5	412,1	1173,6	210	212
IML TSB(2S)-U 80-32-12-6	2	80	32	12,7	71	6	484,7	1425,1	240	244
IML TSB(2S)-U 80-32-12-7	2	80	32	12,7	71	7	555,8	1676,6	270	276
IML TSB(2S)-B 80-32-12-8	2	80	32	12,7	71	8	607,3	1844,2	300	317
IML TSB(2S)-B 80-32-12-9	2	80	32	12,7	71	9	678,8	2107,7	340	349
IML TSB(2S)-B 80-32-12-10	2	80	32	12,7	71	10	744,1	2347,2	370	369
IML TSB(2S)-U 80-40-12-2	2	80	40	12,7	71	2	188,3	429,4	80	126
IML TSB(2S)-U 80-40-12-3	2	80	40	12,7	71	3	263,7	679,8	120	166
IML TSB(2S)-U 80-40-12-4	2	80	40	12,7	71	4	339	930,3	160	206
IML TSB(2S)-U 80-40-12-5	2	80	40	12,7	71	5	412,8	1180,8	200	246
IML TSB(2S)-U 80-40-12-6	2	80	40	12,7	71	6	484,9	1431,2	230	286
IML TSB(2S)-B 80-40-12-7	2	80	40	12,7	71	7	537	1598,2	260	343
IML TSB(2S)-B 80-40-12-8	2	80	40	12,7	71	8	609,3	1860,6	290	368
IML TSB(2S)-B 80-40-15-2	2	80	40	15,875	67	2	250	514,9	180	131
IML TSB(2S)-B 80-40-15-3	2	80	40	15,875	67	3	356,8	839,1	290	171
IML TSB(2S)-B 80-40-15-4	2	80	40	15,875	67	4	457,7	1144,2	400	211
IML TSB(2S)-B 80-40-15-5	2	80	40	15,875	67	5	561,4	1468,4	490	251
IML TSB(2S)-B 80-40-15-6	2	80	40	15,875	67	6	634,1	1678,1	550	311
IML TSB(2S)-B 80-40-15-7	2	80	40	15,875	67	7	729,3	1983,3	640	351
IML TSB(2S)-U 80-50-15-2	2	80	50	15,875	67	2	248	511,6	180	147
IML TSB(2S)-U 80-50-15-3	2	80	50	15,875	67	3	353,9	833,7	290	197
IML TSB(2S)-U 80-50-15-4	2	80	50	15,875	67	4	458,9	1155,9	390	247
IML TSB(2S)-U 80-50-15-5	2	80	50	15,875	67	5	556,7	1459	480	297
IML TSB(2S)-B 80-50-15-6	2	80	50	15,875	67	6	628,9	1667,5	530	358
IML TSB(2S)-B 80-50-19-2	2	80	50	19,05	64,1	2	306,3	591,9	250	157
IML TSB(2S)-B 80-50-19-3	2	80	50	19,05	64,1	3	438,3	968,5	390	207
IML TSB(2S)-B 80-50-19-4	2	80	50	19,05	64,1	4	569,1	1345,2	520	257
IML TSB(2S)-B 80-50-19-5	2	80	50	19,05	64,1	5	652,6	1560,4	590	332
IML TSB(2S)-B 80-50-19-6	2	80	50	19,05	64,1	6	778,9	1937	720	368

- C_a and C_{oa} : Modified static and dynamic load capacities, calculated according to DIN 69051/4 standard and ISO3408/5. See Technical description catalogue.

- Check with SHUTON-IPIRANGA in case higher loads or more adjusted nut dimensions are required.

- Check external maximum axial force in the two senses.

For the indicated leads, in case C_a and C_{oa} requirements is lower, there is possibility of smaller size balls.

Maximum force (Peak load CO-CO and TR-TR) calculated with the flange/nut clamping in opposite position to the main support of the shaft, with same load type (traction or compression) in both nut and shaft. For same-side clamping, so different type of load, contact SHUTON-IPIRANGA as peak load is lower.

Nut dimensions									Grease quantity TS
$D_{1, std}$	$D_{1, min}$	D_4	D_6	D_5	L_7	L_1	L_8	L_9	$Q_{Gr} [cm^3]$
150		176	202	17,5	50	40	155	178,5	full=277
150		176	202	17,5	50	40	155	178,5	full=341
150		176	202	17,5	50	40	155	178,5	full=369
150		176	202	17,5	50	40	155	178,5	full=375
135	(130)	155 (150)	175 (170)	13,5	25	25	140 (135)	157,5 (152,5)	full=78
135	(130)	155 (150)	175 (170)	13,5	25	25	140 (135)	157,5 (152,5)	full=97
135	(130)	155 (150)	175 (170)	13,5	25	25	140 (135)	157,5 (152,5)	full=116
135	(130)	155 (150)	175 (170)	13,5	25	25	140 (135)	157,5 (152,5)	full=136
135	(130)	155 (150)	175 (170)	13,5	25	25	140 (135)	157,5 (152,5)	full=156
135	(130)	155 (150)	175 (170)	13,5	25	25	140 (135)	157,5 (152,5)	full=178
130		150	170	13,5	40	25	135	152,5	full=231
130		150	170	13,5	40	25	135	152,5	full=249
130		150	170	13,5	40	25	135	152,5	full=252
135	(130)	155 (150)	175 (170)	13,5	25	25	140 (135)	157,5 (152,5)	full=80
135	(130)	155 (150)	175 (170)	13,5	25	25	140 (135)	157,5 (152,5)	full=104
135	(130)	155 (150)	175 (170)	13,5	25	25	140 (135)	157,5 (152,5)	full=129
135	(130)	155 (150)	175 (170)	13,5	25	25	140 (135)	157,5 (152,5)	full=153
135	(130)	155 (150)	175 (170)	13,5	25	25	140 (135)	157,5 (152,5)	full=179
130		150	170	13,5	40	25	135	152,5	full=243
130		150	170	13,5	40	25	135	152,5	full=247
140		166	192	17,5	45	25	145	168,5	full=141
140		166	192	17,5	45	25	145	168,5	full=170
140		166	192	17,5	45	25	145	168,5	full=203
140		166	192	17,5	45	25	145	168,5	full=236
140		166	192	17,5	45	25	145	168,5	full=316
140		166	192	17,5	45	25	145	168,5	full=352
140		160	180	13,5	25	25	145	162,5	full=96
140		160	180	13,5	25	25	145	162,5	full=132
140		160	180	13,5	25	25	145	162,5	full=168
140		160	180	13,5	25	25	145	162,5	full=209
140		166	192	17,5	45	25	145	168,5	full=321
150		176	202	17,5	50	40	155	178,5	full=201
150		176	202	17,5	50	40	155	178,5	full=246
150		176	202	17,5	50	40	155	178,5	full=297
150		176	202	17,5	50	40	155	178,5	full=421
150		176	202	17,5	50	40	155	178,5	full=432

SHUTON-IPIRANGA advises to use the dimensions of the tables, although it is possible to manufacture ball screw with other dimensions. In brackets () second options.

Smaller nut diameters than the first option of the table can reduce the rigidity of the assembly between 5 and 10%. Please consult SHUTON-IPIRANGA.

High Load IML TS Single nut, DN up to 170.000

Ball screw reference	Number of starts	Nominal diameter (mm)	Lead (mm)	Ball Diameter (mm)	Root diameter (mm)	Circuits	Dynamic load capacity	Static load capacity	Peak load CO-CO TR-TR 'TS'	Nut length
	$l/2$	d_o	P_h	D_w	d_2	i	C_a [kN]	C_{oa} [kN]	F_{max} [kN]	$L_{n,std}$ [mm]
IML TSB-B 100-12,7-9-7	1	100	12,7	9,525	92,2	7	251,3	863,1	280	137
IML TSB-B 100-12,7-9-8	1	100	12,7	9,525	92,2	8	283,3	995	320	150
IML TSB-B 100-12,7-9-9	1	100	12,7	9,525	92,2	9	317	1138,8	360	163
IML TSB-B 100-12,7-9-10	1	100	12,7	9,525	92,2	10	343,5	1246,7	390	177
IML TSB-B 100-12,7-9-11	1	100	12,7	9,525	92,2	11	373,3	1374,6	430	189
IML TSB-B 100-12,7-9-12	1	100	12,7	9,525	92,2	12	405,6	1518,4	470	202
IML TSB-B 100-12,7-9-13	1	100	12,7	9,525	92,2	13	429,8	1618,3	500	215
IML TSB-B 100-12,7-9-14	1	100	12,7	9,525	92,2	14	460,7	1758,2	540	228
IML TSB-B 100-12,7-9-15	1	100	12,7	9,525	92,2	15	491,3	1898	580	241
IML TSB-B 100-15-9-6	1	100	15	9,525	92,2	6	224,1	759	240	137
IML TSB-B 100-15-9-7	1	100	15	9,525	92,2	7	251,2	862,8	280	155
IML TSB-B 100-15-9-8	1	100	15	9,525	92,2	8	283,2	994,7	310	170
IML TSB-B 100-15-9-9	1	100	15	9,525	92,2	9	316,8	1138,5	360	185
IML TSB-B 100-15-9-10	1	100	15	9,525	92,2	10	343,4	1246,3	390	201
IML TSB-B 100-15-9-11	1	100	15	9,525	92,2	11	373,2	1374,2	430	216
IML TSB-B 100-15-9-12	1	100	15	9,525	92,2	12	405,5	1518	470	231
IML TSB-B 100-15-9-13	1	100	15	9,525	92,2	13	429,6	1617,8	500	247
IML TSB-B 100-15-9-14	1	100	15	9,525	92,2	14	460,5	1757,6	540	262
IML TSB-B 100-15-9-15	1	100	15	9,525	92,2	15	491,1	1897,5	570	277
IML TSB-U 100-16-12-2	1	100	16	12,7	91	2	136,3	328,8	60	78
IML TSB-U 100-16-12-3	1	100	16	12,7	91	3	190,4	518,8	95	94
IML TSB-U 100-16-12-4	1	100	16	12,7	91	4	244,5	708,8	130	110
IML TSB-U 100-16-12-5	1	100	16	12,7	91	5	295,9	891,5	160	126
IML TSB-U 100-16-12-6	1	100	16	12,7	91	6	347,9	1081,4	190	142
IML TSB-U 100-16-12-7	1	100	16	12,7	91	7	398,7	1271,4	220	158
IML TSB-U 100-16-12-8	1	100	16	12,7	91	8	448,6	1461,4	250	174
IML TSB-B 100-16-12-9	1	100	16	12,7	91	9	478,3	1556,4	280	198
IML TSB-B 100-16-12-10	1	100	16	12,7	91	10	524	1731,8	310	214
IML TSB-B 100-16-12-11	1	100	16	12,7	91	11	573,5	1929,1	340	230
IML TSB-B 100-16-12-12	1	100	16	12,7	91	12	622,2	2126,4	370	246
IML TSB-B 100-16-12-13	1	100	16	12,7	91	13	656,2	2250,6	390	263
IML TSB-B 100-16-12-14	1	100	16	12,7	91	14	705,4	2455,2	420	279
IML TSB-B 100-16-12-15	1	100	16	12,7	91	15	748,5	2630,5	450	295
IML TSB-B 100-16-12-16	1	100	16	12,7	91	16	796,6	2835,1	470	311
IML TSB-B 100-16-12-17	1	100	16	12,7	91	17	829,3	2959,4	500	328
IML TSB-B 100-16-12-18	1	100	16	12,7	91	18	872,7	3142	520	344

- C_a and C_{oa} : Modified static and dynamic load capacities, calculated according to DIN 69051/4 standard and ISO3408/5. See Technical description catalogue.

- Check with SHUTON-IPIRANGA in case higher loads or more adjusted nut dimensions are required.

- Check external maximum axial force in the two senses.

For the indicated leads, in case C_a and C_{oa} requirements is lower, there is possibility of smaller size balls.

Maximum force (Peak load CO-CO and TR-TR) calculated with the flange/nut clamping in opposite position to the main support of the shaft, with same load type (traction or compression) in both nut and shaft. For same-side clamping, so different type of load, contact SHUTON-IPIRANGA as peak load is lower.

Nut dimensions									Grease quantity TS
$D_{1, std}$	$D_{1, min}$	D_4	D_6	D_5	L_7	L_1	L_8	L_9	$Q_{Gr} [cm^3]$
140		166	192	17,5	35	25	145	168,5	full=97
140		166	192	17,5	35	25	145	168,5	full=105
140		166	192	17,5	35	25	145	168,5	full=112
140		166	192	17,5	35	25	145	168,5	full=123
140		166	192	17,5	35	25	145	168,5	full=129
140		166	192	17,5	35	25	145	168,5	full=137
140		166	192	17,5	35	25	145	168,5	full=146
140		166	192	17,5	35	25	145	168,5	full=153
140		166	192	17,5	35	25	145	168,5	full=161
140		166	192	17,5	35	25	145	168,5	full=89
140		166	192	17,5	35	25	145	168,5	full=102
140		166	192	17,5	35	25	145	168,5	full=111
140		166	192	17,5	35	25	145	168,5	full=118
140		166	192	17,5	35	25	145	168,5	full=130
140		166	192	17,5	35	25	145	168,5	full=138
140		166	192	17,5	35	25	145	168,5	full=145
140		166	192	17,5	35	25	145	168,5	full=157
140		166	192	17,5	35	25	145	168,5	full=164
140		166	192	17,5	35	25	145	168,5	full=173
150		176	202	17,5	30	25	155	178,5	full=52
150		176	202	17,5	30	25	155	178,5	full=63
150		176	202	17,5	30	25	155	178,5	full=75
150		176	202	17,5	30	25	155	178,5	full=88
150		176	202	17,5	30	25	155	178,5	full=101
150		176	202	17,5	30	25	155	178,5	full=115
150		176	202	17,5	30	25	155	178,5	full=129
155	(150)	181 (176)	207 (202)	17,5	40	25	160 (155)	183,5 (178,5)	full=182
155	(150)	181 (176)	207 (202)	17,5	40	25	160 (155)	183,5 (178,5)	full=196
155	(150)	181 (176)	207 (202)	17,5	40	25	160 (155)	183,5 (178,5)	full=208
155	(150)	181 (176)	207 (202)	17,5	40	25	160 (155)	183,5 (178,5)	full=219
155	(150)	181 (176)	207 (202)	17,5	40	25	160 (155)	183,5 (178,5)	full=237
155	(150)	181 (176)	207 (202)	17,5	40	25	160 (155)	183,5 (178,5)	full=248
155	(150)	181 (176)	207 (202)	17,5	40	25	160 (155)	183,5 (178,5)	full=260
155	(150)	181 (176)	207 (202)	17,5	40	25	160 (155)	183,5 (178,5)	full=271
155	(150)	181 (176)	207 (202)	17,5	40	25	160 (155)	183,5 (178,5)	full=288
155	(150)	181 (176)	207 (202)	17,5	40	25	160 (155)	183,5 (178,5)	full=302

SHUTON-IPIRANGA advises to use the dimensions of the tables, although it is possible to manufacture ball screw with other dimensions. In brackets () second options.

Smaller nut diameters than the first option of the table can reduce the rigidity of the assembly between 5 and 10%. Please consult SHUTON-IPIRANGA.

High Load IML TS Single nut, DN up to 170.000

Ball screw reference	Number of starts	Nominal diameter (mm)	Lead (mm)	Ball Diameter (mm)	Root diameter (mm)	Circuits	Dynamic load capacity	Static load capacity	Peak load CO-CO TR-TR 'TS'	Nut length
	$l/2$	d_0	P_h	D_w	d_2	i	C_a [kN]	C_{oa} [kN]	F_{max} [kN]	L_{nstd} [mm]
IML TSB-B 100-16-12-19	1	100	16	12,7	91	19	915,7	3324,7	540	358
IML TSB-B 100-16-12-20	1	100	16	12,7	91	20	965	3543,9	570	374
IML TSB-U 100-20-12-2	1	100	20	12,7	91	2	136,2	328,6	60	99
IML TSB-U 100-20-12-3	1	100	20	12,7	91	3	190,2	518,5	95	119
IML TSB-U 100-20-12-4	1	100	20	12,7	91	4	244,3	708,3	130	139
IML TSB-U 100-20-12-5	1	100	20	12,7	91	5	295,7	890,9	160	159
IML TSB-U 100-20-12-6	1	100	20	12,7	91	6	347,5	1080,7	190	180
IML TSB-U 100-20-12-7	1	100	20	12,7	91	7	398,3	1270,6	210	199
IML TSB-U 100-20-12-8	1	100	20	12,7	91	8	448,2	1460,4	240	219
IML TSB-B 100-20-12-9	1	100	20	12,7	91	9	477,9	1555,4	270	237
IML TSB-B 100-20-12-10	1	100	20	12,7	91	10	523,6	1730,6	300	257
IML TSB-B 100-20-12-11	1	100	20	12,7	91	11	573	1927,8	330	277
IML TSB-B 100-20-12-12	1	100	20	12,7	91	12	621,7	2124,9	360	297
IML TSB-B 100-20-12-13	1	100	20	12,7	91	13	655,6	2249,1	380	318
IML TSB-B 100-20-12-14	1	100	20	12,7	91	14	704,8	2453,5	400	338
IML TSB-B 100-20-12-15	1	100	20	12,7	91	15	747,8	2628,8	430	356
IML TSB-B 100-20-12-16	1	100	20	12,7	91	16	795,9	2833,2	450	376
IML TSB-B 100-20-12-17	1	100	20	12,7	91	17	828,6	2957,4	470	397
IML TSB-B 100-20-12-18	1	100	20	12,7	91	18	871,9	3139,9	490	417
IML TSB-B 100-20-12-19	1	100	20	12,7	91	19	914,9	3322,5	500	437
IML TSB-B 100-20-12-20	1	100	20	12,7	91	20	964,2	3541,5	530	457
IML TSB-U 100-20-15-2	1	100	20	15,875	87	2	183,6	398,4	140	88
IML TSB-U 100-20-15-3	1	100	20	15,875	87	3	260,8	644,5	230	108
IML TSB-U 100-20-15-4	1	100	20	15,875	87	4	334,5	878,9	310	128
IML TSB-U 100-20-15-5	1	100	20	15,875	87	5	409,5	1125	390	148
IML TSB-U 100-20-15-6	1	100	20	15,875	87	6	480,1	1359,3	460	168
IML TSB-U 100-20-15-7	1	100	20	15,875	87	7	551,9	1605,4	530	188
IML TSB-U 100-20-15-8	1	100	20	15,875	87	8	619,7	1839,8	600	208
IML TSB-U 100-20-15-9	1	100	20	15,875	87	9	689	2085,9	660	228
IML TSB-U 100-20-15-10	1	100	20	15,875	87	10	754,7	2320,2	700	248
IML TSB-B 100-20-15-11	1	100	20	15,875	87	11	791,7	2425,7	810	283
IML TSB-B 100-20-15-12	1	100	20	15,875	87	12	851	2636,6	860	303
IML TSB-B 100-20-15-13	1	100	20	15,875	87	13	917,2	2882,7	940	323
IML TSB-B 100-20-15-14	1	100	20	15,875	87	14	982,5	3128,8	1000	343
IML TSB-B 100-20-15-15	1	100	20	15,875	87	15	1047,2	3374,9	1050	361
IML TSB-B 100-20-15-16	1	100	20	15,875	87	16	1089,5	3515,5	1100	382

- C_a and C_{oa} : Modified static and dynamic load capacities, calculated according to DIN 69051/4 standard and ISO3408/5. See Technical description catalogue.

- Check with SHUTON-IPIRANGA in case higher loads or more adjusted nut dimensions are required.

- Check external maximum axial force in the two senses.

For the indicated leads, in case C_a and C_{oa} requirements is lower, there is possibility of smaller size balls.

Maximum force (Peak load CO-CO and TR-TR) calculated with the flange/nut clamping in opposite position to the main support of the shaft, with same load type (traction or compression) in both nut and shaft. For same-side clamping, so different type of load, contact SHUTON-IPIRANGA as peak load is lower.

Nut dimensions									Grease quantity TS
$D_{1, std}$	$D_{1, min}$	D_4	D_6	D_5	L_7	L_1	L_8	L_9	$Q_{Gr} [cm^3]$
155	(150)	181 (176)	207 (202)	17,5	40	25	160 (155)	183,5 (178,5)	full=309
155	(150)	181 (176)	207 (202)	17,5	40	25	160 (155)	183,5 (178,5)	full=320
150		176	202	17,5	30	25	155	178,5	full=76
150		176	202	17,5	30	25	155	178,5	full=90
150		176	202	17,5	30	25	155	178,5	full=105
150		176	202	17,5	30	25	155	178,5	full=121
150		176	202	17,5	30	25	155	178,5	full=139
150		176	202	17,5	30	25	155	178,5	full=154
150		176	202	17,5	30	25	155	178,5	full=171
155	(150)	181 (176)	207 (202)	17,5	40	25	160 (155)	183,5 (178,5)	full=207
155	(150)	181 (176)	207 (202)	17,5	40	25	160 (155)	183,5 (178,5)	full=224
155	(150)	181 (176)	207 (202)	17,5	40	25	160 (155)	183,5 (178,5)	full=238
155	(150)	181 (176)	207 (202)	17,5	40	25	160 (155)	183,5 (178,5)	full=253
155	(150)	181 (176)	207 (202)	17,5	40	25	160 (155)	183,5 (178,5)	full=273
155	(150)	181 (176)	207 (202)	17,5	40	25	160 (155)	183,5 (178,5)	full=288
155	(150)	181 (176)	207 (202)	17,5	40	25	160 (155)	183,5 (178,5)	full=299
155	(150)	181 (176)	207 (202)	17,5	40	25	160 (155)	183,5 (178,5)	full=314
155	(150)	181 (176)	207 (202)	17,5	40	25	160 (155)	183,5 (178,5)	full=333
155	(150)	181 (176)	207 (202)	17,5	40	25	160 (155)	183,5 (178,5)	full=350
155	(150)	181 (176)	207 (202)	17,5	40	25	160 (155)	183,5 (178,5)	full=364
155	(150)	181 (176)	207 (202)	17,5	40	25	160 (155)	183,5 (178,5)	full=378
160		186	212	17,5	30	40	165	188,5	full=75
160		186	212	17,5	30	40	165	188,5	full=94
160		186	212	17,5	30	40	165	188,5	full=115
160		186	212	17,5	30	40	165	188,5	full=134
160		186	212	17,5	30	40	165	188,5	full=156
160		186	212	17,5	30	40	165	188,5	full=178
160		186	212	17,5	30	40	165	188,5	full=203
160		186	212	17,5	30	40	165	188,5	full=228
160		186	212	17,5	30	40	165	188,5	full=257
165	(160)	191 (186)	217 (212)	17,5	45	40	170 (165)	193,5 (188,5)	full=344
165	(160)	191 (186)	217 (212)	17,5	45	40	170 (165)	193,5 (188,5)	full=369
165	(160)	191 (186)	217 (212)	17,5	45	40	170 (165)	193,5 (188,5)	full=386
165	(160)	194 (189)	223 (218)	20	45	40	170 (165)	196,5 (191,5)	full=406
165	(160)	194 (189)	223 (218)	20	45	40	170 (165)	196,5 (191,5)	full=423
165	(160)	194 (189)	223 (218)	20	45	40	170 (165)	196,5 (191,5)	full=454

SHUTON-IPIRANGA advises to use the dimensions of the tables, although it is possible to manufacture ball screw with other dimensions. In brackets () second options.

Smaller nut diameters than the first option of the table can reduce the rigidity of the assembly between 5 and 10%. Please consult SHUTON-IPIRANGA.

High Load IML TS Single nut, DN up to 170.000

Ball screw reference	Number of starts	Nominal diameter (mm)	Lead (mm)	Ball Diameter (mm)	Root diameter (mm)	Circuits	Dynamic load capacity	Static load capacity	Peak load CO-CO TR-TR 'TS'	Nut length
	$l/2$	d_0	P_h	D_w	d_2	i	C_a [kN]	C_{oa} [kN]	F_{max} [kN]	$L_{n, std}$ [mm]
IML TSB-B 100-20-15-17	1	100	20	15,875	87	17	1160,4	3796,7	1150	402
IML TSB-B 100-20-15-18	1	100	20	15,875	87	18	1221	4031,1	1200	422
IML TSB-B 100-20-15-19	1	100	20	15,875	87	19	1281,2	4265,5	1250	442
IML TSB-B 100-20-15-20	1	100	20	15,875	87	20	1340,9	4499,9	1300	462
IML TSB(2S)-U 100-25-9-2	2	100	25	9,525	92,2	2	141	405,3	130	95
IML TSB(2S)-U 100-25-9-3	2	100	25	9,525	92,2	3	195,2	631,3	200	120
IML TSB(2S)-U 100-25-9-4	2	100	25	9,525	92,2	4	248,4	850,5	270	145
IML TSB(2S)-U 100-25-9-5	2	100	25	9,525	92,2	5	301,8	1076,5	330	170
IML TSB-U 100-25-15-2	1	100	25	15,875	87	2	183,4	398	140	97
IML TSB-U 100-25-15-3	1	100	25	15,875	87	3	260,4	643,8	230	122
IML TSB-U 100-25-15-4	1	100	25	15,875	87	4	334	877,9	310	147
IML TSB-U 100-25-15-5	1	100	25	15,875	87	5	409	1123,8	390	172
IML TSB-U 100-25-15-6	1	100	25	15,875	87	6	479,4	1357,9	460	197
IML TSB-U 100-25-15-7	1	100	25	15,875	87	7	551,2	1603,7	530	222
IML TSB-U 100-25-15-8	1	100	25	15,875	87	8	618,9	1837,8	580	247
IML TSB-U 100-25-15-9	1	100	25	15,875	87	9	688,1	2083,7	640	272
IML TSB-B 100-25-15-10	1	100	25	15,875	87	10	738,4	2247,5	730	312
IML TSB-B 100-25-15-11	1	100	25	15,875	87	11	790,6	2423,1	780	341
IML TSB-B 100-25-15-12	1	100	25	15,875	87	12	849,8	2633,8	830	364
IML TSB-B 100-25-15-13	1	100	25	15,875	87	13	915,9	2879,7	890	389
IML TSB-B 100-25-15-14	1	100	25	15,875	87	14	981,2	3125,5	940	414
IML TSB-B 100-25-15-15	1	100	25	15,875	87	15	1045,8	3371,3	980	439
IML TSB-B 100-25-15-16	1	100	25	15,875	87	16	1088	3511,8	1000	466
IML TSB-B 100-25-15-17	1	100	25	15,875	87	17	1158,8	3792,7	1050	485
IML TSB-B 100-25-19-2	1	100	25	19,05	84,1	2	230,5	466,8	190	105
IML TSB-B 100-25-19-3	1	100	25	19,05	84,1	3	325,9	750,2	310	130
IML TSB-B 100-25-19-4	1	100	25	19,05	84,1	4	421	1033,6	420	155
IML TSB-B 100-25-19-5	1	100	25	19,05	84,1	5	513,9	1317	520	180
IML TSB-B 100-25-19-6	1	100	25	19,05	84,1	6	604,7	1600,4	620	205
IML TSB-B 100-25-19-7	1	100	25	19,05	84,1	7	693,6	1883,8	710	230
IML TSB-B 100-25-19-8	1	100	25	19,05	84,1	8	756,7	2067,1	800	268
IML TSB-B 100-25-19-9	1	100	25	19,05	84,1	9	846,9	2367,2	900	293
IML TSB-B 100-25-19-10	1	100	25	19,05	84,1	10	927,8	2633,9	980	318
IML TSB-B 100-25-19-11	1	100	25	19,05	84,1	11	1015,3	2934	1050	343
IML TSB-B 100-25-19-12	1	100	25	19,05	84,1	12	1094	3200,7	1150	366
IML TSB-B 100-25-19-13	1	100	25	19,05	84,1	13	1179,3	3500,8	1200	391

- C_a and C_{oa} : Modified static and dynamic load capacities, calculated according to DIN 69051/4 standard and ISO3408/5. See Technical description catalogue.

- Check with SHUTON-IPIRANGA in case higher loads or more adjusted nut dimensions are required.

- Check external maximum axial force in the two senses.

For the indicated leads, in case C_a and C_{oa} requirements is lower, there is possibility of smaller size balls.

Maximum force (Peak load CO-CO and TR-TR) calculated with the flange/nut clamping in opposite position to the main support of the shaft, with same load type (traction or compression) in both nut and shaft. For same-side clamping, so different type of load, contact SHUTON-IPIRANGA as peak load is lower.

Nut dimensions									Grease quantity TS
$D_{1, std}$	$D_{1, min}$	D_4	D_6	D_5	L_7	L_1	L_8	L_9	$Q_{Gr} [cm^3]$
165	(160)	194 (189)	223 (218)	20	45	40	170 (165)	196,5 (191,5)	full=466
165	(160)	197 (192)	229 (224)	22	45	40	170 (165)	199,5 (194,5)	full=490
165	(160)	197 (192)	229 (224)	22	45	40	170 (165)	199,5 (194,5)	full=508
165	(160)	197 (192)	229 (224)	22	45	40	170 (165)	199,5 (194,5)	full=531
150	(140)	176 (166)	202 (192)	17,5	30	25	155 (145)	178,5 (168,5)	full=58
150	(140)	176 (166)	202 (192)	17,5	30	25	155 (145)	178,5 (168,5)	full=72
150	(140)	176 (166)	202 (192)	17,5	30	25	155 (145)	178,5 (168,5)	full=88
150	(140)	176 (166)	202 (192)	17,5	30	25	155 (145)	178,5 (168,5)	full=103
160		186	212	17,5	30	40	165	188,5	full=76
160		186	212	17,5	30	40	165	188,5	full=99
160		186	212	17,5	30	40	165	188,5	full=123
160		186	212	17,5	30	40	165	188,5	full=146
160		186	212	17,5	30	40	165	188,5	full=172
160		186	212	17,5	30	40	165	188,5	full=197
160		186	212	17,5	30	40	165	188,5	full=226
160		186	212	17,5	30	40	165	188,5	full=254
165	(160)	191 (186)	217 (212)	17,5	45	40	170 (165)	193,5 (188,5)	full=339
165	(160)	191 (186)	217 (212)	17,5	45	40	170 (165)	193,5 (188,5)	full=374
165	(160)	191 (186)	217 (212)	17,5	45	40	170 (165)	193,5 (188,5)	full=399
165	(160)	191 (186)	217 (212)	17,5	45	40	170 (165)	193,5 (188,5)	full=419
165	(160)	191 (186)	217 (212)	17,5	45	40	170 (165)	193,5 (188,5)	full=443
165	(160)	191 (186)	217 (212)	17,5	45	40	170 (165)	193,5 (188,5)	full=468
165	(160)	194 (189)	223 (218)	20	45	40	170 (165)	196,5 (191,5)	full=504
165	(160)	194 (189)	223 (218)	20	45	40	170 (165)	196,5 (191,5)	full=508
175	(170)	201 (196)	227 (222)	17,5	50	40	180 (175)	203,5 (198,5)	full=174
175	(170)	201 (196)	227 (222)	17,5	50	40	180 (175)	203,5 (198,5)	full=202
175	(170)	201 (196)	227 (222)	17,5	50	40	180 (175)	203,5 (198,5)	full=233
175	(170)	201 (196)	227 (222)	17,5	50	40	180 (175)	203,5 (198,5)	full=263
175	(170)	201 (196)	227 (222)	17,5	50	40	180 (175)	203,5 (198,5)	full=294
175	(170)	201 (196)	227 (222)	17,5	50	40	180 (175)	203,5 (198,5)	full=329
175	(170)	201 (196)	227 (222)	17,5	50	40	180 (175)	203,5 (198,5)	full=396
175	(170)	201 (196)	227 (222)	17,5	50	40	180 (175)	203,5 (198,5)	full=424
175	(170)	201 (196)	227 (222)	17,5	50	40	180 (175)	203,5 (198,5)	full=457
175	(170)	204 (199)	233 (228)	20	50	40	180 (175)	206,5 (201,5)	full=485
175	(170)	204 (199)	233 (228)	20	50	40	180 (175)	206,5 (201,5)	full=513
175	(170)	207 (202)	239 (234)	22	50	40	180 (175)	209,5 (204,5)	full=545

SHUTON-IPIRANGA advises to use the dimensions of the tables, although it is possible to manufacture ball screw with other dimensions. In brackets () second options.

Smaller nut diameters than the first option of the table can reduce the rigidity of the assembly between 5 and 10%. Please consult SHUTON-IPIRANGA.

High Load IML TS Single nut, DN up to 170.000

Ball screw reference	Number of starts	Nominal diameter (mm)	Lead (mm)	Ball Diameter (mm)	Root diameter (mm)	Circuits	Dynamic load capacity	Static load capacity	Peak load CO-CO TR-TR 'TS'	Nut length
	$l/2$	d_0	P_h	D_w	d_2	i	C_a [kN]	C_{oa} [kN]	F_{max} [kN]	L_{nstd} [mm]
IML TSB-B 100-25-19-14	1	100	25	19,05	84,1	14	1256,3	3767,5	1250	416
IML TSB-B 100-25-19-15	1	100	25	19,05	84,1	15	1314	3950,9	1300	445
IML TSB-B 100-25-19-16	1	100	25	19,05	84,1	16	1397	4251	1400	470
IML TSB(2S)-U 100-30-9-2	2	100	30	9,525	92,2	2	140,7	404,8	130	102
IML TSB(2S)-U 100-30-9-3	2	100	30	9,525	92,2	3	194,9	630,4	200	132
IML TSB(2S)-U 100-30-9-4	2	100	30	9,525	92,2	4	249,2	856	270	162
IML TSB(2S)-U 100-30-9-5	2	100	30	9,525	92,2	5	301,3	1075	330	192
IML TSB(2S)-B 100-30-9-6	2	100	30	9,525	92,2	6	346,3	1260,8	380	235
IML TSB(2S)-B 100-30-9-7	2	100	30	9,525	92,2	7	388,1	1433,4	440	270
IML TSB(2S)-B 100-30-9-8	2	100	30	9,525	92,2	8	441	1672,3	500	300
IML TSB(2S)-B 100-30-9-9	2	100	30	9,525	92,2	9	489,5	1891,3	550	330
IML TSB(2S)-B 100-30-9-10	2	100	30	9,525	92,2	10	530,5	2070,4	590	360
IML TSB(2S)-B 100-30-9-11	2	100	30	9,525	92,2	11	576,6	2282,8	630	390
IML TSB(2S)-B 100-30-9-12	2	100	30	9,525	92,2	12	626,5	2521,7	670	420
IML TSB-B 100-30-19-2	1	100	30	19,05	84,1	2	230,1	466,2	190	115
IML TSB-B 100-30-19-3	1	100	30	19,05	84,1	3	325,4	749,2	310	145
IML TSB-B 100-30-19-4	1	100	30	19,05	84,1	4	420,2	1032,2	410	175
IML TSB-B 100-30-19-5	1	100	30	19,05	84,1	5	513	1315,3	520	205
IML TSB-B 100-30-19-6	1	100	30	19,05	84,1	6	603,7	1598,3	620	235
IML TSB-B 100-30-19-7	1	100	30	19,05	84,1	7	696,5	1898	700	265
IML TSB-B 100-30-19-8	1	100	30	19,05	84,1	8	755,4	2064,5	780	310
IML TSB-B 100-30-19-9	1	100	30	19,05	84,1	9	845,5	2364,2	870	340
IML TSB-B 100-30-19-10	1	100	30	19,05	84,1	10	926,2	2630,5	950	368
IML TSB-B 100-30-19-11	1	100	30	19,05	84,1	11	1013,6	2930,2	1000	398
IML TSB-B 100-30-19-12	1	100	30	19,05	84,1	12	1092,2	3196,6	1100	428
IML TSB-B 100-30-19-13	1	100	30	19,05	84,1	13	1177,4	3496,3	1150	458
IML TSB-B 100-30-19-14	1	100	30	19,05	84,1	14	1261,5	3796	1150	480
IML TSB(2S)-U 100-32-12-2	2	100	32	12,7	91	2	210,6	546,1	100	117
IML TSB(2S)-U 100-32-12-3	2	100	32	12,7	91	3	294,1	861,6	150	149
IML TSB(2S)-U 100-32-12-4	2	100	32	12,7	91	4	377,7	1177,1	210	181
IML TSB(2S)-U 100-32-12-5	2	100	32	12,7	91	5	459,6	1492,6	260	213
IML TSB(2S)-U 100-32-12-6	2	100	32	12,7	91	6	539,7	1808,1	300	245
IML TSB(2S)-U 100-32-12-7	2	100	32	12,7	91	7	615,7	2111,5	350	277
IML TSB(2S)-B 100-32-12-8	2	100	32	12,7	91	8	678,9	2354,2	390	317
IML TSB(2S)-B 100-32-12-9	2	100	32	12,7	91	9	738,8	2584,7	430	355
IML TSB(2S)-B 100-32-12-10	2	100	32	12,7	91	10	816,2	2912,4	460	385

- C_a and C_{oa} : Modified static and dynamic load capacities, calculated according to DIN 69051/4 standard and ISO3408/5. See Technical description catalogue.

- Check with SHUTON-IPIRANGA in case higher loads or more adjusted nut dimensions are required.

- Check external maximum axial force in the two senses.

For the indicated leads, in case C_a and C_{oa} requirements is lower, there is possibility of smaller size balls.

Maximum force (Peak load CO-CO and TR-TR) calculated with the flange/nut clamping in opposite position to the main support of the shaft, with same load type (traction or compression) in both nut and shaft. For same-side clamping, so different type of load, contact SHUTON-IPIRANGA as peak load is lower.

Nut dimensions									Grease quantity TS
$D_{1, std}$	$D_{1, min}$	D_4	D_6	D_5	L_7	L_1	L_8	L_9	$Q_{Gr} [cm^3]$
175	(170)	207 (202)	239 (234)	22	50	40	180 (175)	209,5 (204,5)	full=583
175	(170)	207 (202)	239 (234)	22	50	40	180 (175)	209,5 (204,5)	full=622
175	(170)	207 (202)	239 (234)	22	50	40	180 (175)	209,5 (204,5)	full=652
150	(140)	176 (166)	202 (192)	17,5	30	25	155 (145)	178,5 (168,5)	full=58
150	(140)	176 (166)	202 (192)	17,5	30	25	155 (145)	178,5 (168,5)	full=75
150	(140)	176 (166)	202 (192)	17,5	30	25	155 (145)	178,5 (168,5)	full=91
150	(140)	176 (166)	202 (192)	17,5	30	25	155 (145)	178,5 (168,5)	full=109
140		166	192	17,5	35	25	145	168,5	full=151
140		166	192	17,5	35	25	145	168,5	full=176
140		166	192	17,5	35	25	145	168,5	full=192
140		166	192	17,5	35	25	145	168,5	full=209
140		166	192	17,5	35	25	145	168,5	full=229
140		166	192	17,5	35	25	145	168,5	full=245
140		166	192	17,5	35	25	145	168,5	full=261
175	(170)	201 (196)	227 (222)	17,5	50	40	180 (175)	203,5 (198,5)	full=170
175	(170)	201 (196)	227 (222)	17,5	50	40	180 (175)	203,5 (198,5)	full=202
175	(170)	201 (196)	227 (222)	17,5	50	40	180 (175)	203,5 (198,5)	full=236
175	(170)	201 (196)	227 (222)	17,5	50	40	180 (175)	203,5 (198,5)	full=270
175	(170)	201 (196)	227 (222)	17,5	50	40	180 (175)	203,5 (198,5)	full=304
175	(170)	201 (196)	227 (222)	17,5	50	40	180 (175)	203,5 (198,5)	full=341
175	(170)	201 (196)	227 (222)	17,5	50	40	180 (175)	203,5 (198,5)	full=415
175	(170)	201 (196)	227 (222)	17,5	50	40	180 (175)	203,5 (198,5)	full=447
175	(170)	201 (196)	227 (222)	17,5	50	40	180 (175)	203,5 (198,5)	full=479
175	(170)	204 (199)	233 (228)	20	50	40	180 (175)	206,5 (201,5)	full=511
175	(170)	204 (199)	233 (228)	20	50	40	180 (175)	206,5 (201,5)	full=548
175	(170)	204 (199)	233 (228)	20	50	40	180 (175)	206,5 (201,5)	full=584
175	(170)	204 (199)	233 (228)	20	50	40	180 (175)	206,5 (201,5)	full=602
150		176	202	17,5	30	25	155	178,5	full=98
150		176	202	17,5	30	25	155	178,5	full=120
150		176	202	17,5	30	25	155	178,5	full=144
150		176	202	17,5	30	25	155	178,5	full=169
150		176	202	17,5	30	25	155	178,5	full=195
150		176	202	17,5	30	25	155	178,5	full=224
155	(150)	181 (176)	207 (202)	17,5	40	25	160 (155)	183,5 (178,5)	full=280
155	(150)	181 (176)	207 (202)	17,5	40	25	160 (155)	183,5 (178,5)	full=318
155	(150)	181 (176)	207 (202)	17,5	40	25	160 (155)	183,5 (178,5)	full=337

SHUTON-IPIRANGA advises to use the dimensions of the tables, although it is possible to manufacture ball screw with other dimensions. In brackets () second options.

Smaller nut diameters than the first option of the table can reduce the rigidity of the assembly between 5 and 10%. Please consult SHUTON-IPIRANGA.

High Load IML TS Single nut, DN up to 170.000

Ball screw reference	Number of starts	Nominal diameter (mm)	Lead (mm)	Ball Diameter (mm)	Root diameter (mm)	Circuits	Dynamic load capacity	Static load capacity	Peak load CO-CO TR-TR 'TS'	Nut length
	$l/2$	d_0	P_h	D_w	d_2	i	C_a [kN]	C_{oa} [kN]	F_{max} [kN]	$L_{n, std}$ [mm]
IML TSB(2S)-B 100-32-12-11	2	100	32	12,7	91	11	885,7	3203,6	490	417
IML TSB(2S)-B 100-32-12-12	2	100	32	12,7	91	12	961	3531,3	520	449
IML TSB(2S)-B 100-32-12-13	2	100	32	12,7	91	13	1022,2	3786,1	550	483
IML TSB(2S)-B 100-32-12-14	2	100	32	12,7	91	14	1089,4	4077,3	570	515
IML TSB(2S)-B 100-32-12-15	2	100	32	12,7	91	15	1155,9	4368,6	580	539
IML TSB(2S)-U 100-40-12-2	2	100	40	12,7	91	2	209,8	544,6	95	127
IML TSB(2S)-U 100-40-12-3	2	100	40	12,7	91	3	293,1	859,3	150	167
IML TSB(2S)-U 100-40-12-4	2	100	40	12,7	91	4	376,4	1174	200	207
IML TSB(2S)-U 100-40-12-5	2	100	40	12,7	91	5	458	1488,6	250	247
IML TSB(2S)-U 100-40-12-6	2	100	40	12,7	91	6	537,8	1803,3	290	287
IML TSB(2S)-B 100-40-12-7	2	100	40	12,7	91	7	599,4	2033,2	330	343
IML TSB(2S)-B 100-40-12-8	2	100	40	12,7	91	8	676,5	2347,9	370	381
IML TSB(2S)-B 100-40-12-9	2	100	40	12,7	91	9	736,2	2577,9	400	428
IML TSB(2S)-B 100-40-12-10	2	100	40	12,7	91	10	813,3	2904,6	430	468
IML TSB(2S)-B 100-40-12-11	2	100	40	12,7	91	11	889,3	3231,4	450	508
IML TSB(2S)-B 100-40-12-12	2	100	40	12,7	91	12	957,6	3521,9	460	535
IML TSB(2S)-U 100-40-15-2	2	100	40	15,875	87	2	288,3	679,7	240	135
IML TSB(2S)-U 100-40-15-3	2	100	40	15,875	87	3	401,6	1068,1	370	175
IML TSB(2S)-U 100-40-15-4	2	100	40	15,875	87	4	519,7	1476	500	215
IML TSB(2S)-U 100-40-15-5	2	100	40	15,875	87	5	630,8	1864,4	620	255
IML TSB(2S)-U 100-40-15-6	2	100	40	15,875	87	6	743,7	2272,2	740	295
IML TSB(2S)-B 100-40-15-7	2	100	40	15,875	87	7	829,3	2563,5	830	351
IML TSB(2S)-B 100-40-15-8	2	100	40	15,875	87	8	934,2	2951,9	910	389
IML TSB(2S)-B 100-40-15-9	2	100	40	15,875	87	9	1037,3	3340,3	990	429
IML TSB(2S)-B 100-40-15-10	2	100	40	15,875	87	10	1138,9	3728,8	1050	469
IML TSB(2S)-B 100-40-15-11	2	100	40	15,875	87	11	1219,4	4020,1	1100	503
IML TSB(2S)-B 100-40-15-12	2	100	40	15,875	87	12	1322,4	4427,9	1150	543
IML TSB(2S)-U 100-50-15-2	2	100	50	15,875	87	2	286,8	676,9	240	149
IML TSB(2S)-U 100-50-15-3	2	100	50	15,875	87	3	404,3	1083	370	199
IML TSB(2S)-U 100-50-15-4	2	100	50	15,875	87	4	516,9	1469,8	490	249
IML TSB(2S)-U 100-50-15-5	2	100	50	15,875	87	5	631,7	1875,9	600	299
IML TSB(2S)-B 100-50-15-6	2	100	50	15,875	87	6	718,5	2166	680	372
IML TSB(2S)-B 100-50-15-7	2	100	50	15,875	87	7	824,8	2552,8	780	422
IML TSB(2S)-B 100-50-15-8	2	100	50	15,875	87	8	929,1	2939,6	830	472
IML TSB(2S)-B 100-50-15-9	2	100	50	15,875	87	9	1015,6	3249	860	514
IML TSB(2S)-B 100-50-19-2	2	100	50	19,05	84,1	2	353,6	771,2	310	157

- C_a and C_{oa} : Modified static and dynamic load capacities, calculated according to DIN 69051/4 standard and ISO3408/5. See Technical description catalogue.

- Check with SHUTON-IPIRANGA in case higher loads or more adjusted nut dimensions are required.

- Check external maximum axial force in the two senses.

For the indicated leads, in case C_a and C_{oa} requirements is lower, there is possibility of smaller size balls.

Maximum force (Peak load CO-CO and TR-TR) calculated with the flange/nut clamping in opposite position to the main support of the shaft, with same load type (traction or compression) in both nut and shaft. For same-side clamping, so different type of load, contact SHUTON-IPIRANGA as peak load is lower.

Nut dimensions									Grease quantity TS
$D_{1, std}$	$D_{1, min}$	D_4	D_6	D_5	L_7	L_1	L_8	L_9	$Q_{Gr} [cm^3]$
155	(150)	181 (176)	207 (202)	17,5	40	25	160 (155)	183,5 (178,5)	full=365
155	(150)	181 (176)	207 (202)	17,5	40	25	160 (155)	183,5 (178,5)	full=388
155	(150)	181 (176)	207 (202)	17,5	40	25	160 (155)	183,5 (178,5)	full=418
155	(150)	181 (176)	207 (202)	17,5	40	25	160 (155)	183,5 (178,5)	full=446
155	(150)	181 (176)	207 (202)	17,5	40	25	160 (155)	183,5 (178,5)	full=455
150		176	202	17,5	30	25	155	178,5	full=102
150		176	202	17,5	30	25	155	178,5	full=130
150		176	202	17,5	30	25	155	178,5	full=161
150		176	202	17,5	30	25	155	178,5	full=192
150		176	202	17,5	30	25	155	178,5	full=224
155	(150)	181 (176)	207 (202)	17,5	40	25	160 (155)	183,5 (178,5)	full=297
155	(150)	181 (176)	207 (202)	17,5	40	25	160 (155)	183,5 (178,5)	full=323
155	(150)	181 (176)	207 (202)	17,5	40	25	160 (155)	183,5 (178,5)	full=368
155	(150)	181 (176)	207 (202)	17,5	40	25	160 (155)	183,5 (178,5)	full=397
155	(150)	181 (176)	207 (202)	17,5	40	25	160 (155)	183,5 (178,5)	full=427
155	(150)	181 (176)	207 (202)	17,5	40	25	160 (155)	183,5 (178,5)	full=440
160		186	212	17,5	30	40	165	188,5	full=110
160		186	212	17,5	30	40	165	188,5	full=152
160		186	212	17,5	30	40	165	188,5	full=191
160		186	212	17,5	30	40	165	188,5	full=233
160		186	212	17,5	30	40	165	188,5	full=275
165	(160)	191 (186)	217 (212)	17,5	45	40	170 (165)	193,5 (188,5)	full=420
165	(160)	191 (186)	217 (212)	17,5	45	40	170 (165)	193,5 (188,5)	full=463
165	(160)	194 (189)	223 (218)	20	45	40	170 (165)	196,5 (191,5)	full=505
165	(160)	194 (189)	223 (218)	20	45	40	170 (165)	196,5 (191,5)	full=547
165	(160)	194 (189)	223 (218)	20	45	40	170 (165)	196,5 (191,5)	full=581
165	(160)	194 (189)	223 (218)	20	45	40	170 (165)	196,5 (191,5)	full=622
160		186	212	17,5	30	40	165	188,5	full=119
160		186	212	17,5	30	40	165	188,5	full=165
160		186	212	17,5	30	40	165	188,5	full=214
160		186	212	17,5	30	40	165	188,5	full=260
165	(160)	191 (186)	217 (212)	17,5	45	40	170 (165)	193,5 (188,5)	full=417
165	(160)	191 (186)	217 (212)	17,5	45	40	170 (165)	193,5 (188,5)	full=461
165	(160)	191 (186)	217 (212)	17,5	45	40	170 (165)	193,5 (188,5)	full=516
165	(160)	191 (186)	217 (212)	17,5	45	40	170 (165)	193,5 (188,5)	full=554
175	(170)	201 (196)	227 (222)	17,5	50	40	180 (175)	203,5 (198,5)	full=247

SHUTON-IPIRANGA advises to use the dimensions of the tables, although it is possible to manufacture ball screw with other dimensions. In brackets () second options.

Smaller nut diameters than the first option of the table can reduce the rigidity of the assembly between 5 and 10%. Please consult SHUTON-IPIRANGA.

High Load IML TS Single nut, DN up to 170.000

Ball screw reference	Number of starts	Nominal diameter (mm)	Lead (mm)	Ball Diameter (mm)	Root diameter (mm)	Circuits	Dynamic load capacity	Static load capacity	Peak load CO-CO TR-TR 'TS'	Nut length
	$l/2$	d_0	P_h	D_w	d_2	i	C_a [kN]	C_{oa} [kN]	F_{max} [kN]	L_{nstd} [mm]
IML TSB(2S)-B 100-50-19-3	2	100	50	19,05	84,1	3	500	1239,4	490	207
IML TSB(2S)-B 100-50-19-4	2	100	50	19,05	84,1	4	652,7	1735,2	670	257
IML TSB(2S)-B 100-50-19-5	2	100	50	19,05	84,1	5	754,7	2038,1	790	332
IML TSB(2S)-B 100-50-19-6	2	100	50	19,05	84,1	6	888,6	2478,8	910	380
IML TSB(2S)-B 100-50-19-7	2	100	50	19,05	84,1	7	1032,5	2974,6	1050	430
IML TSB(2S)-B 100-50-19-8	2	100	50	19,05	84,1	8	1173,2	3470,3	1150	480
IML TSB(2S)-B 100-50-19-9	2	100	50	19,05	84,1	9	1256,2	3718,2	1150	526
IML TSB-B 120-12,7-9-6	1	120	12,7	9,525	112,2	6	241,6	916,4	290	123
IML TSB-B 120-12,7-9-7	1	120	12,7	9,525	112,2	7	272,1	1049,1	340	137
IML TSB-B 120-12,7-9-8	1	120	12,7	9,525	112,2	8	308,2	1217,9	390	150
IML TSB-B 120-12,7-9-9	1	120	12,7	9,525	112,2	9	341,6	1374,6	430	163
IML TSB-B 120-12,7-9-10	1	120	12,7	9,525	112,2	10	371,2	1511,3	480	177
IML TSB-B 120-12,7-9-11	1	120	12,7	9,525	112,2	11	404,4	1672,1	530	189
IML TSB-B 120-12,7-9-12	1	120	12,7	9,525	112,2	12	437,2	1832,9	570	202
IML TSB-B 120-12,7-9-13	1	120	12,7	9,525	112,2	13	465,7	1969,5	610	215
IML TSB-B 120-12,7-9-14	1	120	12,7	9,525	112,2	14	497,8	2130,3	660	228
IML TSB-B 120-12,7-9-15	1	120	12,7	9,525	112,2	15	529,5	2291,1	710	241
IML TSB-B 120-15-9-5	1	120	15	9,525	112,2	5	205,6	755,5	240	122
IML TSB-B 120-15-9-6	1	120	15	9,525	112,2	6	241,6	916,2	290	137
IML TSB-B 120-15-9-7	1	120	15	9,525	112,2	7	272	1048,8	340	155
IML TSB-B 120-15-9-8	1	120	15	9,525	112,2	8	308,1	1217,6	380	170
IML TSB-B 120-15-9-9	1	120	15	9,525	112,2	9	341,5	1374,4	430	185
IML TSB-B 120-15-9-10	1	120	15	9,525	112,2	10	371,1	1511	480	201
IML TSB-B 120-15-9-11	1	120	15	9,525	112,2	11	404,3	1671,7	520	216
IML TSB-B 120-15-9-12	1	120	15	9,525	112,2	12	437,1	1832,5	570	231
IML TSB-B 120-15-9-13	1	120	15	9,525	112,2	13	465,6	1969,1	610	247
IML TSB-B 120-15-9-14	1	120	15	9,525	112,2	14	497,7	2129,8	650	262
IML TSB-B 120-15-9-15	1	120	15	9,525	112,2	15	529,4	2290,6	700	277
IML TSB-U 120-16-12-2	1	120	16	12,7	111	2	149,4	404,9	75	79
IML TSB-U 120-16-12-3	1	120	16	12,7	111	3	207,5	633,1	110	95
IML TSB-U 120-16-12-4	1	120	16	12,7	111	4	264,2	854	150	111
IML TSB-U 120-16-12-5	1	120	16	12,7	111	5	321,3	1082,2	190	127
IML TSB-U 120-16-12-6	1	120	16	12,7	111	6	377,2	1310,4	230	143
IML TSB-U 120-16-12-7	1	120	16	12,7	111	7	430,6	1531,3	260	159
IML TSB-B 120-16-12-8	1	120	16	12,7	111	8	465,3	1656,4	290	182
IML TSB-B 120-16-12-9	1	120	16	12,7	111	9	521,2	1899,4	340	198

- C_a and C_{oa} : Modified static and dynamic load capacities, calculated according to DIN 69051/4 standard and ISO3408/5. See Technical description catalogue.

- Check with SHUTON-IPIRANGA in case higher loads or more adjusted nut dimensions are required.

- Check external maximum axial force in the two senses.

For the indicated leads, in case C_a and C_{oa} requirements is lower, there is possibility of smaller size balls.

Maximum force (Peak load CO-CO and TR-TR) calculated with the flange/nut clamping in opposite position to the main support of the shaft, with same load type (traction or compression) in both nut and shaft. For same-side clamping, so different type of load, contact SHUTON-IPIRANGA as peak load is lower.

Nut dimensions									Grease quantity TS
$D_{1, std}$	$D_{1, min}$	D_4	D_6	D_5	L_7	L_1	L_8	L_9	$Q_{Gr} [cm^3]$
175	(170)	201 (196)	227 (222)	17,5	50	40	180 (175)	203,5 (198,5)	full=304
175	(170)	201 (196)	227 (222)	17,5	50	40	180 (175)	203,5 (198,5)	full=361
175	(170)	201 (196)	227 (222)	17,5	50	40	180 (175)	203,5 (198,5)	full=504
175	(170)	201 (196)	227 (222)	17,5	50	40	180 (175)	203,5 (198,5)	full=565
175	(170)	204 (199)	233 (228)	20	50	40	180 (175)	206,5 (201,5)	full=622
175	(170)	204 (199)	233 (228)	20	50	40	180 (175)	206,5 (201,5)	full=679
175	(170)	204 (199)	233 (228)	20	50	40	180 (175)	206,5 (201,5)	full=754
160		186	212	17,5	35	25	165	188,5	full=103
160		186	212	17,5	35	25	165	188,5	full=116
160		186	212	17,5	35	25	165	188,5	full=124
160		186	212	17,5	35	25	165	188,5	full=134
160		186	212	17,5	35	25	165	188,5	full=145
160		186	212	17,5	35	25	165	188,5	full=153
160		186	212	17,5	35	25	165	188,5	full=163
160		186	212	17,5	35	25	165	188,5	full=173
160		186	212	17,5	35	25	165	188,5	full=182
160		186	212	17,5	35	25	165	188,5	full=192
160		186	212	17,5	35	25	165	188,5	full=95
160		186	212	17,5	35	25	165	188,5	full=106
160		186	212	17,5	35	25	165	188,5	full=121
160		186	212	17,5	35	25	165	188,5	full=131
160		186	212	17,5	35	25	165	188,5	full=141
160		186	212	17,5	35	25	165	188,5	full=153
160		186	212	17,5	35	25	165	188,5	full=163
160		186	212	17,5	35	25	165	188,5	full=173
160		186	212	17,5	35	25	165	188,5	full=186
160		186	212	17,5	35	25	165	188,5	full=195
160		186	212	17,5	35	25	165	188,5	full=206
170		196	222	17,5	30	25	175	198,5	full=63
170		196	222	17,5	30	25	175	198,5	full=77
170		196	222	17,5	30	25	175	198,5	full=92
170		196	222	17,5	30	25	175	198,5	full=107
170		196	222	17,5	30	25	175	198,5	full=122
170		196	222	17,5	30	25	175	198,5	full=139
175	(170)	201 (196)	227 (222)	17,5	40	40	180 (175)	203,5 (198,5)	full=205
175	(170)	201 (196)	227 (222)	17,5	40	40	180 (175)	203,5 (198,5)	full=215

SHUTON-IPIRANGA advises to use the dimensions of the tables, although it is possible to manufacture ball screw with other dimensions. In brackets () second options.

Smaller nut diameters than the first option of the table can reduce the rigidity of the assembly between 5 and 10%. Please consult SHUTON-IPIRANGA.

High Load IML TS Single nut, DN up to 170.000

Ball screw reference	Number of starts	Nominal diameter (mm)	Lead (mm)	Ball Diameter (mm)	Root diameter (mm)	Circuits	Dynamic load capacity	Static load capacity	Peak load CO-CO TR-TR 'TS'	Nut length
	$l/2$	d_0	P_h	D_w	d_2	i	C_a [kN]	C_{oa} [kN]	F_{max} [kN]	$L_{n, std}$ [mm]
IML TSB-B 120-16-12-10	1	120	16	12,7	111	10	561,6	2061,3	370	215
IML TSB-B 120-16-12-11	1	120	16	12,7	111	11	614,7	2296,9	400	231
IML TSB-B 120-16-12-12	1	120	16	12,7	111	12	667,1	2532,5	440	247
IML TSB-B 120-16-12-13	1	120	16	12,7	111	13	704,7	2687,1	470	264
IML TSB-B 120-16-12-14	1	120	16	12,7	111	14	753,4	2908	500	280
IML TSB-B 120-16-12-15	1	120	16	12,7	111	15	808	3165,6	540	296
IML TSB-B 120-16-12-16	1	120	16	12,7	111	16	843,2	3312,9	560	313
IML TSB-B 120-16-12-17	1	120	16	12,7	111	17	890,7	3533,7	590	329
IML TSB-B 120-16-12-18	1	120	16	12,7	111	18	945	3798,8	630	345
IML TSB-U 120-20-12-2	1	120	20	12,7	111	2	149,4	404,7	75	100
IML TSB-U 120-20-12-3	1	120	20	12,7	111	3	207,3	632,8	110	120
IML TSB-U 120-20-12-4	1	120	20	12,7	111	4	264	853,6	150	140
IML TSB-U 120-20-12-5	1	120	20	12,7	111	5	321,1	1081,7	190	160
IML TSB-U 120-20-12-6	1	120	20	12,7	111	6	377	1309,8	230	180
IML TSB-B 120-20-12-7	1	120	20	12,7	111	7	412,2	1434,9	260	197
IML TSB-B 120-20-12-8	1	120	20	12,7	111	8	465	1655,7	290	217
IML TSB-B 120-20-12-9	1	120	20	12,7	111	9	520,9	1898,5	340	237
IML TSB-B 120-20-12-10	1	120	20	12,7	111	10	561,2	2060,4	360	258
IML TSB-B 120-20-12-11	1	120	20	12,7	111	11	614,3	2295,8	400	278
IML TSB-B 120-20-12-12	1	120	20	12,7	111	12	666,7	2531,3	430	298
IML TSB-B 120-20-12-13	1	120	20	12,7	111	13	704,3	2685,8	460	319
IML TSB-B 120-20-12-14	1	120	20	12,7	111	14	759,3	2943,4	490	339
IML TSB-B 120-20-12-15	1	120	20	12,7	111	15	807,5	3164,1	520	357
IML TSB-U 120-20-15-2	1	120	20	15,875	107	2	204	497,1	180	89
IML TSB-U 120-20-15-3	1	120	20	15,875	107	3	287	793	280	109
IML TSB-U 120-20-15-4	1	120	20	15,875	107	4	367,1	1077	380	129
IML TSB-U 120-20-15-5	1	120	20	15,875	107	5	448,3	1372,9	470	149
IML TSB-U 120-20-15-6	1	120	20	15,875	107	6	525,1	1657	560	169
IML TSB-U 120-20-15-7	1	120	20	15,875	107	7	600,3	1941	640	189
IML TSB-U 120-20-15-8	1	120	20	15,875	107	8	676,6	2236,9	720	209
IML TSB-B 120-20-15-9	1	120	20	15,875	107	9	732,8	2438,1	820	239
IML TSB-B 120-20-15-10	1	120	20	15,875	107	10	809,3	2745,8	910	259
IML TSB-B 120-20-15-11	1	120	20	15,875	107	11	863,9	2947	980	283
IML TSB-B 120-20-15-12	1	120	20	15,875	107	12	934	3231,1	1050	303
IML TSB-B 120-20-15-13	1	120	20	15,875	107	13	1003,3	3515,1	1150	323
IML TSB-B 120-20-15-14	1	120	20	15,875	107	14	1071,8	3799,2	1200	343

- C_a and C_{oa} : Modified static and dynamic load capacities, calculated according to DIN 69051/4 standard and ISO3408/5. See Technical description catalogue.

- Check with SHUTON-IPIRANGA in case higher loads or more adjusted nut dimensions are required.

- Check external maximum axial force in the two senses.

For the indicated leads, in case C_a and C_{oa} requirements is lower, there is possibility of smaller size balls.

Maximum force (Peak load CO-CO and TR-TR) calculated with the flange/nut clamping in opposite position to the main support of the shaft, with same load type (traction or compression) in both nut and shaft. For same-side clamping, so different type of load, contact SHUTON-IPIRANGA as peak load is lower.

Nut dimensions									Grease quantity TS
$D_{1, std}$	$D_{1, min}$	D_4	D_6	D_5	L_7	L_1	L_8	L_9	$Q_{Gr} [cm^3]$
175	(170)	201 (196)	227 (222)	17,5	40	40	180 (175)	203,5 (198,5)	full=237
175	(170)	201 (196)	227 (222)	17,5	40	40	180 (175)	203,5 (198,5)	full=251
175	(170)	201 (196)	227 (222)	17,5	40	40	180 (175)	203,5 (198,5)	full=262
175	(170)	201 (196)	227 (222)	17,5	40	40	180 (175)	203,5 (198,5)	full=283
175	(170)	201 (196)	227 (222)	17,5	40	40	180 (175)	203,5 (198,5)	full=300
175	(170)	201 (196)	227 (222)	17,5	40	40	180 (175)	203,5 (198,5)	full=309
175	(170)	201 (196)	227 (222)	17,5	40	40	180 (175)	203,5 (198,5)	full=334
175	(170)	201 (196)	227 (222)	17,5	40	40	180 (175)	203,5 (198,5)	full=347
175	(170)	201 (196)	227 (222)	17,5	40	40	180 (175)	203,5 (198,5)	full=356
170		196	222	17,5	30	25	175	198,5	full=91
170		196	222	17,5	30	25	175	198,5	full=109
170		196	222	17,5	30	25	175	198,5	full=127
170		196	222	17,5	30	25	175	198,5	full=146
170		196	222	17,5	30	25	175	198,5	full=165
175	(170)	201 (196)	227 (222)	17,5	40	40	180 (175)	203,5 (198,5)	full=211
175	(170)	201 (196)	227 (222)	17,5	40	40	180 (175)	203,5 (198,5)	full=230
175	(170)	201 (196)	227 (222)	17,5	40	40	180 (175)	203,5 (198,5)	full=244
175	(170)	201 (196)	227 (222)	17,5	40	40	180 (175)	203,5 (198,5)	full=269
175	(170)	201 (196)	227 (222)	17,5	40	40	180 (175)	203,5 (198,5)	full=287
175	(170)	201 (196)	227 (222)	17,5	40	40	180 (175)	203,5 (198,5)	full=302
175	(170)	201 (196)	227 (222)	17,5	40	40	180 (175)	203,5 (198,5)	full=326
175	(170)	201 (196)	227 (222)	17,5	40	40	180 (175)	203,5 (198,5)	full=343
175	(170)	201 (196)	227 (222)	17,5	40	40	180 (175)	203,5 (198,5)	full=355
180		206	232	17,5	30	40	185	208,5	full=89
180		206	232	17,5	30	40	185	208,5	full=112
180		206	232	17,5	30	40	185	208,5	full=137
180		206	232	17,5	30	40	185	208,5	full=161
180		206	232	17,5	30	40	185	208,5	full=187
180		206	232	17,5	30	40	185	208,5	full=215
180		206	232	17,5	30	40	185	208,5	full=243
185		211	237	17,5	45	40	190	213,5	full=345
185		211	237	17,5	45	40	190	213,5	full=369
185		211	237	17,5	45	40	190	213,5	full=408
185		214	243	20	45	40	190	216,5	full=434
185		214	243	20	45	40	190	216,5	full=455
185		217	249	22	45	40	190	219,5	full=480

SHUTON-IPIRANGA advises to use the dimensions of the tables, although it is possible to manufacture ball screw with other dimensions. In brackets () second options.

Smaller nut diameters than the first option of the table can reduce the rigidity of the assembly between 5 and 10%. Please consult SHUTON-IPIRANGA.

High Load IML TS Single nut, DN up to 170.000

Ball screw reference	Number of starts	Nominal diameter (mm)	Lead (mm)	Ball Diameter (mm)	Root diameter (mm)	Circuits	Dynamic load capacity	Static load capacity	Peak load CO-CO TR-TR 'TS'	Nut length
	$l/2$	d_0	P_h	D_w	d_2	i	C_a [kN]	C_{oa} [kN]	F_{max} [kN]	$L_{n, std}$ [mm]
IML TSB-B 120-20-15-15	1	120	20	15,875	107	15	1146,2	4118,7	1300	361
IML TSB-B 120-20-15-16	1	120	20	15,875	107	16	1195,8	4308,1	1350	382
IML TSB-B 120-20-15-17	1	120	20	15,875	107	17	1262,5	4592,1	1400	402
IML TSB-B 120-20-15-18	1	120	20	15,875	107	18	1328,6	4876,2	1450	422
IML TSB-B 120-20-15-19	1	120	20	15,875	107	19	1402,7	5207,6	1500	442
IML TSB-B 120-20-15-20	1	120	20	15,875	107	20	1467,7	5491,6	1550	462
IML TSB-U 120-25-15-2	1	120	25	15,875	107	2	203,8	496,7	180	98
IML TSB-U 120-25-15-3	1	120	25	15,875	107	3	286,7	792,4	280	123
IML TSB-U 120-25-15-4	1	120	25	15,875	107	4	366,7	1076,2	370	148
IML TSB-U 120-25-15-5	1	120	25	15,875	107	5	447,8	1371,9	470	173
IML TSB-U 120-25-15-6	1	120	25	15,875	107	6	524,6	1655,7	560	198
IML TSB-U 120-25-15-7	1	120	25	15,875	107	7	602,2	1951,4	640	223
IML TSB-U 120-25-15-8	1	120	25	15,875	107	8	676	2235,2	710	248
IML TSB-B 120-25-15-9	1	120	25	15,875	107	9	736,8	2459,9	810	287
IML TSB-B 120-25-15-10	1	120	25	15,875	107	10	808,5	2743,8	880	312
IML TSB-B 120-25-15-11	1	120	25	15,875	107	11	863,1	2944,8	950	341
IML TSB-B 120-25-15-12	1	120	25	15,875	107	12	933,1	3228,7	1000	364
IML TSB-B 120-25-15-13	1	120	25	15,875	107	13	1002,3	3512,5	1100	389
IML TSB-B 120-25-15-14	1	120	25	15,875	107	14	1077,4	3831,8	1150	414
IML TSB-B 120-25-15-15	1	120	25	15,875	107	15	1145,1	4115,7	1200	439
IML TSB-B 120-25-15-16	1	120	25	15,875	107	16	1194,7	4304,9	1200	466
IML TSB-B 120-25-15-17	1	120	25	15,875	107	17	1261,3	4588,7	1250	485
IML TSB-U 120-25-19-2	1	120	25	19,05	104,1	2	254,9	573,8	230	100
IML TSB-U 120-25-19-3	1	120	25	19,05	104,1	3	361,9	928,2	370	125
IML TSB-U 120-25-19-4	1	120	25	19,05	104,1	4	464,2	1265,7	510	150
IML TSB-U 120-25-19-5	1	120	25	19,05	104,1	5	568,4	1620,1	640	175
IML TSB-U 120-25-19-6	1	120	25	19,05	104,1	6	666,4	1957,6	760	200
IML TSB-U 120-25-19-7	1	120	25	19,05	104,1	7	762,3	2295,1	860	225
IML TSB-U 120-25-19-8	1	120	25	19,05	104,1	8	860,2	2649,5	970	250
IML TSB-U 120-25-19-9	1	120	25	19,05	104,1	9	952,8	2987	1050	275
IML TSB-U 120-25-19-10	1	120	25	19,05	104,1	10	1047,5	3341,4	1100	300
IML TSB-B 120-25-19-11	1	120	25	19,05	104,1	11	1116,5	3577,7	1300	343
IML TSB-B 120-25-19-12	1	120	25	19,05	104,1	12	1205,6	3915,2	1400	366
IML TSB-B 120-25-19-13	1	120	25	19,05	104,1	13	1273	4151,5	1500	395
IML TSB-B 120-25-19-14	1	120	25	19,05	104,1	14	1363,7	4505,9	1550	420
IML TSB-B 120-25-19-15	1	120	25	19,05	104,1	15	1453,5	4860,3	1600	445

- C_a and C_{oa} : Modified static and dynamic load capacities, calculated according to DIN 69051/4 standard and ISO3408/5. See Technical description catalogue.

- Check with SHUTON-IPIRANGA in case higher loads or more adjusted nut dimensions are required.

- Check external maximum axial force in the two senses.

For the indicated leads, in case C_a and C_{oa} requirements is lower, there is possibility of smaller size balls.

Maximum force (Peak load CO-CO and TR-TR) calculated with the flange/nut clamping in opposite position to the main support of the shaft, with same load type (traction or compression) in both nut and shaft. For same-side clamping, so different type of load, contact SHUTON-IPIRANGA as peak load is lower.

Nut dimensions									Grease quantity TS
$D_{1, std}$	$D_{1, min}$	D_4	D_6	D_5	L_7	L_1	L_8	L_9	$Q_{Gr} [cm^3]$
185		217	249	22	45	40	190	219,5	full=500
185		217	249	22	45	40	190	219,5	full=532
185		217	249	22	45	40	190	219,5	full=554
185		217	249	22	45	40	190	219,5	full=581
185		217	249	22	45	40	190	219,5	full=602
185		220	255	24	45	40	190	222,5	full=629
180		206	232	17,5	30	40	185	208,5	full=90
180		206	232	17,5	30	40	185	208,5	full=117
180		206	232	17,5	30	40	185	208,5	full=147
180		206	232	17,5	30	40	185	208,5	full=175
180		206	232	17,5	30	40	185	208,5	full=205
180		206	232	17,5	30	40	185	208,5	full=236
180		206	232	17,5	30	40	185	208,5	full=270
185		211	237	17,5	45	40	190	213,5	full=371
185		211	237	17,5	45	40	190	213,5	full=402
185		211	237	17,5	45	40	190	213,5	full=444
185		214	243	20	45	40	190	216,5	full=469
185		214	243	20	45	40	190	216,5	full=494
185		214	243	20	45	40	190	216,5	full=520
185		217	249	22	45	40	190	219,5	full=554
185		217	249	22	45	40	190	219,5	full=592
185		217	249	22	45	40	190	219,5	full=603
190		216	242	17,5	40	40	195	218,5	full=240
190		216	242	17,5	40	40	195	218,5	full=274
190		216	242	17,5	40	40	195	218,5	full=308
190		216	242	17,5	40	40	195	218,5	full=344
190		216	242	17,5	40	40	195	218,5	full=382
190		216	242	17,5	40	40	195	218,5	full=423
190		216	242	17,5	40	40	195	218,5	full=464
190		216	242	17,5	40	40	195	218,5	full=509
190		216	242	17,5	40	40	195	218,5	full=557
195	(190)	227 (222)	259 (254)	22	50	40	200 (195)	229,5 (224,5)	full=571
195	(190)	227 (222)	259 (254)	22	50	40	200 (195)	229,5 (224,5)	full=605
195	(190)	227 (222)	259 (254)	22	50	40	200 (195)	229,5 (224,5)	full=654
195	(190)	230 (225)	265 (260)	24	50	40	200 (195)	232,5 (227,5)	full=690
195	(190)	230 (225)	265 (260)	24	50	40	200 (195)	232,5 (227,5)	full=726

SHUTON-IPIRANGA advises to use the dimensions of the tables, although it is possible to manufacture ball screw with other dimensions. In brackets () second options.

Smaller nut diameters than the first option of the table can reduce the rigidity of the assembly between 5 and 10%. Please consult SHUTON-IPIRANGA.

High Load IML TS Single nut, DN up to 170.000

Ball screw reference	Number of starts	Nominal diameter (mm)	Lead (mm)	Ball Diameter (mm)	Root diameter (mm)	Circuits	Dynamic load capacity	Static load capacity	Peak load CO-CO TR-TR 'TS'	Nut length
	$l/2$	d_0	P_h	D_w	d_2	i	C_a [kN]	C_{oa} [kN]	F_{max} [kN]	$L_{n, std}$ [mm]
IML TSB-B 120-25-19-16	1	120	25	19,05	104,1	16	1532,4	5164	1650	470
IML TSB-B 120-25-19-17	1	120	25	19,05	104,1	17	1620,5	5518,4	1700	487
IML TSB-U 120-30-19-2	1	120	30	19,05	104,1	2	254,6	573,3	230	109
IML TSB-U 120-30-19-3	1	120	30	19,05	104,1	3	361,5	927,3	370	139
IML TSB-U 120-30-19-4	1	120	30	19,05	104,1	4	463,7	1264,5	510	169
IML TSB-U 120-30-19-5	1	120	30	19,05	104,1	5	567,8	1618,6	630	199
IML TSB-U 120-30-19-6	1	120	30	19,05	104,1	6	665,6	1955,8	750	229
IML TSB-U 120-30-19-7	1	120	30	19,05	104,1	7	765,2	2309,9	860	259
IML TSB-U 120-30-19-8	1	120	30	19,05	104,1	8	859,2	2647,1	940	289
IML TSB-B 120-30-19-9	1	120	30	19,05	104,1	9	926,4	2866,3	1050	340
IML TSB-B 120-30-19-10	1	120	30	19,05	104,1	10	1025	3237,2	1150	368
IML TSB-B 120-30-19-11	1	120	30	19,05	104,1	11	1115,2	3574,5	1250	398
IML TSB-B 120-30-19-12	1	120	30	19,05	104,1	12	1204,1	3911,7	1300	428
IML TSB-B 120-30-19-13	1	120	30	19,05	104,1	13	1271,5	4147,7	1400	463
IML TSB-B 120-30-19-14	1	120	30	19,05	104,1	14	1362,1	4501,8	1450	483
IML TSB(2S)-U 120-32-12-2	2	120	32	12,7	111	2	231,1	673,1	120	117
IML TSB(2S)-U 120-32-12-3	2	120	32	12,7	111	3	320,9	1052,6	190	149
IML TSB(2S)-U 120-32-12-4	2	120	32	12,7	111	4	410,9	1432	250	181
IML TSB(2S)-U 120-32-12-5	2	120	32	12,7	111	5	497	1799,1	310	213
IML TSB(2S)-U 120-32-12-6	2	120	32	12,7	111	6	583,4	2178,5	370	245
IML TSB(2S)-B 120-32-12-7	2	120	32	12,7	111	7	637,9	2386,6	410	291
IML TSB(2S)-B 120-32-12-8	2	120	32	12,7	111	8	726	2790,5	470	323
IML TSB(2S)-B 120-32-12-9	2	120	32	12,7	111	9	806,1	3157,7	520	355
IML TSB(2S)-B 120-32-12-10	2	120	32	12,7	111	10	868,5	3426,9	550	387
IML TSB(2S)-B 120-32-12-11	2	120	32	12,7	111	11	950,7	3818,6	600	419
IML TSB(2S)-B 120-32-12-12	2	120	32	12,7	111	12	1031,7	4210,2	640	451
IML TSB(2S)-B 120-32-12-13	2	120	32	12,7	111	13	1099,8	4528,4	660	485
IML TSB(2S)-B 120-32-12-14	2	120	32	12,7	111	14	1175,1	4895,6	680	517
IML TSB(2S)-B 120-32-12-15	2	120	32	12,7	111	15	1249,6	5262,8	700	539
IML TSB(2S)-U 120-40-12-2	2	120	40	12,7	111	2	230,6	671,9	120	128
IML TSB(2S)-U 120-40-12-3	2	120	40	12,7	111	3	320,1	1050,6	190	168
IML TSB(2S)-U 120-40-12-4	2	120	40	12,7	111	4	409,9	1429,3	250	208
IML TSB(2S)-U 120-40-12-5	2	120	40	12,7	111	5	498	1808	310	248
IML TSB(2S)-B 120-40-12-6	2	120	40	12,7	111	6	568,8	2101,2	360	303
IML TSB(2S)-B 120-40-12-7	2	120	40	12,7	111	7	636,4	2382,1	390	350
IML TSB(2S)-B 120-40-12-8	2	120	40	12,7	111	8	724,2	2785,3	440	371

- C_a and C_{oa} : Modified static and dynamic load capacities, calculated according to DIN 69051/4 standard and ISO3408/5. See Technical description catalogue.

- Check with SHUTON-IPIRANGA in case higher loads or more adjusted nut dimensions are required.

- Check external maximum axial force in the two senses.

For the indicated leads, in case C_a and C_{oa} requirements is lower, there is possibility of smaller size balls.

Maximum force (Peak load CO-CO and TR-TR) calculated with the flange/nut clamping in opposite position to the main support of the shaft, with same load type (traction or compression) in both nut and shaft. For same-side clamping, so different type of load, contact SHUTON-IPIRANGA as peak load is lower.

Nut dimensions									Grease quantity TS
$D_{1, std}$	$D_{1, min}$	D_4	D_6	D_5	L_7	L_1	L_8	L_9	$Q_{Gr} [cm^3]$
195	(190)	230 (225)	265 (260)	24	50	40	200 (195)	232,5 (227,5)	full=769
195	(190)	230 (225)	265 (260)	24	50	40	200 (195)	232,5 (227,5)	full=780
190		216	242	17,5	40	40	195	218,5	full=228
190		216	242	17,5	40	40	195	218,5	full=266
190		216	242	17,5	40	40	195	218,5	full=304
190		216	242	17,5	40	40	195	218,5	full=345
190		216	242	17,5	40	40	195	218,5	full=388
190		216	242	17,5	40	40	195	218,5	full=431
190		216	242	17,5	40	40	195	218,5	full=479
195	(190)	224 (219)	253 (248)	20	50	40	200 (195)	226,5 (221,5)	full=531
195	(190)	224 (219)	253 (248)	20	50	40	200 (195)	226,5 (221,5)	full=561
195	(190)	227 (222)	259 (254)	22	50	40	200 (195)	229,5 (224,5)	full=601
195	(190)	227 (222)	259 (254)	22	50	40	200 (195)	229,5 (224,5)	full=647
195	(190)	227 (222)	259 (254)	22	50	40	200 (195)	229,5 (224,5)	full=701
195	(190)	227 (222)	259 (254)	22	50	40	200 (195)	229,5 (224,5)	full=714
170		196	222	17,5	30	25	175	198,5	full=116
170		196	222	17,5	30	25	175	198,5	full=143
170		196	222	17,5	30	25	175	198,5	full=172
170		196	222	17,5	30	25	175	198,5	full=203
170		196	222	17,5	30	25	175	198,5	full=234
175	(170)	201 (196)	227 (222)	17,5	40	40	180 (175)	203,5 (198,5)	full=323
175	(170)	201 (196)	227 (222)	17,5	40	40	180 (175)	203,5 (198,5)	full=348
175	(170)	201 (196)	227 (222)	17,5	40	40	180 (175)	203,5 (198,5)	full=374
175	(170)	201 (196)	227 (222)	17,5	40	40	180 (175)	203,5 (198,5)	full=412
175	(170)	201 (196)	227 (222)	17,5	40	40	180 (175)	203,5 (198,5)	full=441
175	(170)	201 (196)	227 (222)	17,5	40	40	180 (175)	203,5 (198,5)	full=463
175	(170)	201 (196)	227 (222)	17,5	40	40	180 (175)	203,5 (198,5)	full=499
175	(170)	201 (196)	227 (222)	17,5	40	40	180 (175)	203,5 (198,5)	full=532
175	(170)	201 (196)	227 (222)	17,5	40	40	180 (175)	203,5 (198,5)	full=536
170		196	222	17,5	30	25	175	198,5	full=123
170		196	222	17,5	30	25	175	198,5	full=157
170		196	222	17,5	30	25	175	198,5	full=193
170		196	222	17,5	30	25	175	198,5	full=230
175	(170)	201 (196)	227 (222)	17,5	40	40	180 (175)	203,5 (198,5)	full=312
175	(170)	201 (196)	227 (222)	17,5	40	40	180 (175)	203,5 (198,5)	full=371
175	(170)	201 (196)	227 (222)	17,5	40	40	180 (175)	203,5 (198,5)	full=368

SHUTON-IPIRANGA advises to use the dimensions of the tables, although it is possible to manufacture ball screw with other dimensions. In brackets () second options.

Smaller nut diameters than the first option of the table can reduce the rigidity of the assembly between 5 and 10%. Please consult SHUTON-IPIRANGA.

High Load IML TS Single nut, DN up to 170.000

Ball screw reference	Number of starts	Nominal diameter (mm)	Lead (mm)	Ball Diameter (mm)	Root diameter (mm)	Circuits	Dynamic load capacity	Static load capacity	Peak load CO-CO TR-TR 'TS'	Nut length
	$l/2$	d_o	P_h	D_w	d_2	i	C_a [kN]	C_{oa} [kN]	F_{max} [kN]	L_{nstd} [mm]
IML TSB(2S)-B 120-40-12-9	2	120	40	12,7	111	9	804,1	3151,7	490	428
IML TSB(2S)-B 120-40-12-10	2	120	40	12,7	111	10	874,6	3469,3	520	471
IML TSB(2S)-B 120-40-12-11	2	120	40	12,7	111	11	948,3	3811,4	540	511
IML TSB(2S)-B 120-40-12-12	2	120	40	12,7	111	12	1029,1	4202,3	560	536
IML TSB(2S)-U 120-40-15-2	2	120	40	15,875	107	2	319,8	844,8	300	135
IML TSB(2S)-U 120-40-15-3	2	120	40	15,875	107	3	442,9	1316,4	460	175
IML TSB(2S)-U 120-40-15-4	2	120	40	15,875	107	4	570,8	1807,6	610	215
IML TSB(2S)-U 120-40-15-5	2	120	40	15,875	107	5	691,9	2279,1	750	255
IML TSB(2S)-U 120-40-15-6	2	120	40	15,875	107	6	814,4	2770,3	880	295
IML TSB(2S)-B 120-40-15-7	2	120	40	15,875	107	7	904	3104,3	1000	351
IML TSB(2S)-B 120-40-15-8	2	120	40	15,875	107	8	1026	3615,1	1100	389
IML TSB(2S)-B 120-40-15-9	2	120	40	15,875	107	9	1138,5	4086,7	1200	429
IML TSB(2S)-B 120-40-15-10	2	120	40	15,875	107	10	1249,2	4558,2	1300	469
IML TSB(2S)-B 120-40-15-11	2	120	40	15,875	107	11	1333,6	4892,2	1300	503
IML TSB(2S)-B 120-40-15-12	2	120	40	15,875	107	12	1452,3	5422,7	1400	543
IML TSB(2S)-U 120-50-15-2	2	120	50	15,875	107	2	318,6	842,3	300	149
IML TSB(2S)-U 120-50-15-3	2	120	50	15,875	107	3	441,2	1312,5	460	199
IML TSB(2S)-U 120-50-15-4	2	120	50	15,875	107	4	568,6	1802,2	600	249
IML TSB(2S)-U 120-50-15-5	2	120	50	15,875	107	5	689,3	2272,4	730	299
IML TSB(2S)-B 120-50-15-6	2	120	50	15,875	107	6	784,2	2625	830	372
IML TSB(2S)-B 120-50-15-7	2	120	50	15,875	107	7	908,1	3134,3	950	422
IML TSB(2S)-B 120-50-15-8	2	120	50	15,875	107	8	1022	3604,4	1000	472
IML TSB(2S)-B 120-50-15-9	2	120	50	15,875	107	9	1108,5	3937,5	1050	514
IML TSB(2S)-U 120-50-19-2	2	120	50	19,05	104,1	2	399,9	978,4	400	155
IML TSB(2S)-U 120-50-19-3	2	120	50	19,05	104,1	3	557,1	1537,5	600	205
IML TSB(2S)-U 120-50-19-4	2	120	50	19,05	104,1	4	720,9	2124,5	820	255
IML TSB(2S)-U 120-50-19-5	2	120	50	19,05	104,1	5	875	2683,6	990	305
IML TSB(2S)-B 120-50-19-6	2	120	50	19,05	104,1	6	990	3074,9	1100	380
IML TSB(2S)-B 120-50-19-7	2	120	50	19,05	104,1	7	1138,6	3634	1250	430
IML TSB(2S)-B 120-50-19-8	2	120	50	19,05	104,1	8	1295,8	4249	1400	480
IML TSB(2S)-B 120-50-19-9	2	120	50	19,05	104,1	9	1399,5	4612,4	1400	522
IML TSB-U 140-16-12-2	1	140	16	12,7	131	2	160,8	481,1	85	79
IML TSB-U 140-16-12-3	1	140	16	12,7	131	3	220,8	740,1	130	95
IML TSB-U 140-16-12-4	1	140	16	12,7	131	4	282,8	1006,5	180	111
IML TSB-U 140-16-12-5	1	140	16	12,7	131	5	343,5	1273	220	127
IML TSB-U 140-16-12-6	1	140	16	12,7	131	6	401,6	1532	270	143

- C_a and C_{oa} : Modified static and dynamic load capacities, calculated according to DIN 69051/4 standard and ISO3408/5. See Technical description catalogue.

- Check with SHUTON-IPIRANGA in case higher loads or more adjusted nut dimensions are required.

- Check external maximum axial force in the two senses.

For the indicated leads, in case C_a and C_{oa} requirements is lower, there is possibility of smaller size balls.

Maximum force (Peak load CO-CO and TR-TR) calculated with the flange/nut clamping in opposite position to the main support of the shaft, with same load type (traction or compression) in both nut and shaft. For same-side clamping, so different type of load, contact SHUTON-IPIRANGA as peak load is lower.

Nut dimensions									Grease quantity TS
$D_{1, std}$	$D_{1, min}$	D_4	D_6	D_5	L_7	L_1	L_8	L_9	$Q_{Gr} [cm^3]$
175	(170)	201 (196)	227 (222)	17,5	40	40	180 (175)	203,5 (198,5)	full=433
175	(170)	201 (196)	227 (222)	17,5	40	40	180 (175)	203,5 (198,5)	full=479
175	(170)	201 (196)	227 (222)	17,5	40	40	180 (175)	203,5 (198,5)	full=521
175	(170)	201 (196)	227 (222)	17,5	40	40	180 (175)	203,5 (198,5)	full=522
180		206	232	17,5	30	40	185	208,5	full=130
180		206	232	17,5	30	40	185	208,5	full=178
180		206	232	17,5	30	40	185	208,5	full=226
180		206	232	17,5	30	40	185	208,5	full=278
180		206	232	17,5	30	40	185	208,5	full=326
185		214	243	20	45	40	190	216,5	full=501
185		214	243	20	45	40	190	216,5	full=543
185		217	249	22	45	40	190	219,5	full=592
185		217	249	22	45	40	190	219,5	full=646
185		217	249	22	45	40	190	219,5	full=686
185		217	249	22	45	40	190	219,5	full=729
180		206	232	17,5	30	40	185	208,5	full=139
180		206	232	17,5	30	40	185	208,5	full=196
180		206	232	17,5	30	40	185	208,5	full=253
180		206	232	17,5	30	40	185	208,5	full=312
185		211	237	17,5	45	40	190	213,5	full=491
185		211	237	17,5	45	40	190	213,5	full=542
185		214	243	20	45	40	190	216,5	full=605
185		214	243	20	45	40	190	216,5	full=651
190		216	242	17,5	40	40	195	218,5	full=303
190		216	242	17,5	40	40	195	218,5	full=376
190		216	242	17,5	40	40	195	218,5	full=439
190		216	242	17,5	40	40	195	218,5	full=517
195	(190)	224 (219)	253 (248)	20	50	40	200 (195)	226,5 (221,5)	full=663
195	(190)	227 (222)	259 (254)	22	50	40	200 (195)	229,5 (224,5)	full=726
195	(190)	227 (222)	259 (254)	22	50	40	200 (195)	229,5 (224,5)	full=789
195	(190)	227 (222)	259 (254)	22	50	40	200 (195)	229,5 (224,5)	full=870
190		216	242	17,5	30	40	195	218,5	full=73
190		216	242	17,5	30	40	195	218,5	full=89
190		216	242	17,5	30	40	195	218,5	full=106
190		216	242	17,5	30	40	195	218,5	full=123
190		216	242	17,5	30	40	195	218,5	full=141

SHUTON-IPIRANGA advises to use the dimensions of the tables, although it is possible to manufacture ball screw with other dimensions. In brackets () second options.

Smaller nut diameters than the first option of the table can reduce the rigidity of the assembly between 5 and 10%. Please consult SHUTON-IPIRANGA.

High Load IML TS Single nut, DN up to 170.000

Ball screw reference	Number of starts	Nominal diameter (mm)	Lead (mm)	Ball Diameter (mm)	Root diameter (mm)	Circuits	Dynamic load capacity	Static load capacity	Peak load CO-CO TR-TR 'TS'	Nut length
	$l/2$	d_0	P_h	D_w	d_2	i	C_a [kN]	C_{oa} [kN]	F_{max} [kN]	$L_{n,std}$ [mm]
IML TSB-B 140-16-12-7	1	140	16	12,7	131	7	444,5	1709,7	310	166
IML TSB-B 140-16-12-8	1	140	16	12,7	131	8	502	1976,1	350	182
IML TSB-B 140-16-12-9	1	140	16	12,7	131	9	554,8	2220,3	390	198
IML TSB-B 140-16-12-10	1	140	16	12,7	131	10	605,6	2457,2	440	215
IML TSB-B 140-16-12-11	1	140	16	12,7	131	11	660,5	2723,6	480	231
IML TSB-B 140-16-12-12	1	140	16	12,7	131	12	710	2960,4	520	247
IML TSB-B 140-16-12-13	1	140	16	12,7	131	13	756,6	3182,5	560	264
IML TSB-B 140-16-12-14	1	140	16	12,7	131	14	808,6	3441,5	590	280
IML TSB-B 140-16-12-15	1	140	16	12,7	131	15	860	3700,5	630	296
IML TSB-U 140-20-12-2	1	140	20	12,7	131	2	160,7	480,9	85	87
IML TSB-U 140-20-12-3	1	140	20	12,7	131	3	220,7	739,8	130	107
IML TSB-U 140-20-12-4	1	140	20	12,7	131	4	282,6	1006,2	180	127
IML TSB-U 140-20-12-5	1	140	20	12,7	131	5	343,3	1272,5	230	147
IML TSB-B 140-20-12-6	1	140	20	12,7	131	6	392,3	1479,7	270	173
IML TSB-B 140-20-12-7	1	140	20	12,7	131	7	444,3	1709,1	310	197
IML TSB-B 140-20-12-8	1	140	20	12,7	131	8	501,8	1975,4	350	217
IML TSB-B 140-20-12-9	1	140	20	12,7	131	9	554,5	2219,5	390	237
IML TSB-B 140-20-12-10	1	140	20	12,7	131	10	605,3	2456,3	430	258
IML TSB-B 140-20-12-11	1	140	20	12,7	131	11	660,2	2722,6	470	278
IML TSB-B 140-20-12-12	1	140	20	12,7	131	12	709,7	2959,4	510	298
IML TSB-B 140-20-12-13	1	140	20	12,7	131	13	756,3	3181,4	540	319
IML TSB-B 140-20-12-14	1	140	20	12,7	131	14	808,2	3440,3	570	339
IML TSB-B 140-20-12-15	1	140	20	12,7	131	15	859,6	3699,2	610	357
IML TSB-U 140-20-15-2	1	140	20	15,875	127	2	221,4	595,9	210	90
IML TSB-U 140-20-15-3	1	140	20	15,875	127	3	309,5	941,6	330	110
IML TSB-U 140-20-15-4	1	140	20	15,875	127	4	395,1	1275,3	440	130
IML TSB-U 140-20-15-5	1	140	20	15,875	127	5	479,2	1609	550	150
IML TSB-U 140-20-15-6	1	140	20	15,875	127	6	563,8	1954,6	660	170
IML TSB-U 140-20-15-7	1	140	20	15,875	127	7	644,4	2288,4	760	190
IML TSB-B 140-20-15-8	1	140	20	15,875	127	8	710,2	2550,6	870	219
IML TSB-B 140-20-15-9	1	140	20	15,875	127	9	777,4	2824,7	970	243
IML TSB-B 140-20-15-10	1	140	20	15,875	127	10	852,3	3146,5	1050	263
IML TSB-B 140-20-15-11	1	140	20	15,875	127	11	932,5	3504	1150	283
IML TSB-B 140-20-15-12	1	140	20	15,875	127	12	1005,4	3825,8	1250	303
IML TSB-B 140-20-15-13	1	140	20	15,875	127	13	1069,2	4100	1350	324
IML TSB-B 140-20-15-14	1	140	20	15,875	127	14	1142,6	4433,7	1450	344

- C_a and C_{oa} : Modified static and dynamic load capacities, calculated according to DIN 69051/4 standard and ISO3408/5. See Technical description catalogue.

- Check with SHUTON-IPIRANGA in case higher loads or more adjusted nut dimensions are required.

- Check external maximum axial force in the two senses.

For the indicated leads, in case C_a and C_{oa} requirements is lower, there is possibility of smaller size balls.

Maximum force (Peak load CO-CO and TR-TR) calculated with the flange/nut clamping in opposite position to the main support of the shaft, with same load type (traction or compression) in both nut and shaft. For same-side clamping, so different type of load, contact SHUTON-IPIRANGA as peak load is lower.

Nut dimensions									Grease quantity TS
$D_{1, std}$	$D_{1, min}$	D_4	D_6	D_5	L_7	L_1	L_8	L_9	$Q_{Gr} [cm^3]$
195	(190)	221 (216)	247 (242)	17,5	40	40	200 (195)	223,5 (218,5)	full=216
195	(190)	221 (216)	247 (242)	17,5	40	40	200 (195)	223,5 (218,5)	full=232
195	(190)	221 (216)	247 (242)	17,5	40	40	200 (195)	223,5 (218,5)	full=250
195	(190)	221 (216)	247 (242)	17,5	40	40	200 (195)	223,5 (218,5)	full=271
195	(190)	221 (216)	247 (242)	17,5	40	40	200 (195)	223,5 (218,5)	full=285
195	(190)	221 (216)	247 (242)	17,5	40	40	200 (195)	223,5 (218,5)	full=305
195	(190)	221 (216)	247 (242)	17,5	40	40	200 (195)	223,5 (218,5)	full=326
195	(190)	221 (216)	247 (242)	17,5	40	40	200 (195)	223,5 (218,5)	full=344
195	(190)	221 (216)	247 (242)	17,5	40	40	200 (195)	223,5 (218,5)	full=359
190		216	242	17,5	30	40	195	218,5	full=77
190		216	242	17,5	30	40	195	218,5	full=98
190		216	242	17,5	30	40	195	218,5	full=119
190		216	242	17,5	30	40	195	218,5	full=140
195	(190)	221 (216)	247 (242)	17,5	40	40	200 (195)	223,5 (218,5)	full=210
195	(190)	221 (216)	247 (242)	17,5	40	40	200 (195)	223,5 (218,5)	full=241
195	(190)	221 (216)	247 (242)	17,5	40	40	200 (195)	223,5 (218,5)	full=261
195	(190)	221 (216)	247 (242)	17,5	40	40	200 (195)	223,5 (218,5)	full=284
195	(190)	221 (216)	247 (242)	17,5	40	40	200 (195)	223,5 (218,5)	full=309
195	(190)	221 (216)	247 (242)	17,5	40	40	200 (195)	223,5 (218,5)	full=327
195	(190)	221 (216)	247 (242)	17,5	40	40	200 (195)	223,5 (218,5)	full=351
195	(190)	221 (216)	247 (242)	17,5	40	40	200 (195)	223,5 (218,5)	full=376
195	(190)	221 (216)	247 (242)	17,5	40	40	200 (195)	223,5 (218,5)	full=398
195	(190)	221 (216)	247 (242)	17,5	40	40	200 (195)	223,5 (218,5)	full=413
200		226	252	17,5	30	40	205	228,5	full=106
200		226	252	17,5	30	40	205	228,5	full=132
200		226	252	17,5	30	40	205	228,5	full=161
200		226	252	17,5	30	40	205	228,5	full=189
200		226	252	17,5	30	40	205	228,5	full=218
200		226	252	17,5	30	40	205	228,5	full=251
210	(205)	236 (231)	262 (257)	17,5	45	40	215 (210)	238,5 (233,5)	full=369
210	(205)	236 (231)	262 (257)	17,5	45	40	215 (210)	238,5 (233,5)	full=412
210	(205)	239 (234)	268 (263)	20	45	40	215 (210)	241,5 (236,5)	full=442
210	(205)	239 (234)	268 (263)	20	45	40	215 (210)	241,5 (236,5)	full=468
210	(205)	242 (237)	274 (269)	22	45	40	215 (210)	244,5 (239,5)	full=498
210	(205)	242 (237)	274 (269)	22	45	40	215 (210)	244,5 (239,5)	full=533
210	(205)	242 (237)	274 (269)	22	45	40	215 (210)	244,5 (239,5)	full=557

SHUTON-IPIRANGA advises to use the dimensions of the tables, although it is possible to manufacture ball screw with other dimensions. In brackets () second options.

Smaller nut diameters than the first option of the table can reduce the rigidity of the assembly between 5 and 10%. Please consult SHUTON-IPIRANGA.

High Load IML TS Single nut, DN up to 170.000

Ball screw reference	Number of starts	Nominal diameter (mm)	Lead (mm)	Ball Diameter (mm)	Root diameter (mm)	Circuits	Dynamic load capacity	Static load capacity	Peak load CO-CO TR-TR 'TS'	Nut length
	$l/2$	d_0	P_h	D_w	d_2	i	C_a [kN]	C_{oa} [kN]	F_{max} [kN]	$L_{n,std}$ [mm]
IML TSB-B 140-20-15-15	1	140	20	15,875	127	15	1215,3	4767,4	1500	362
IML TSB-B 140-20-15-16	1	140	20	15,875	127	16	1287,2	5101,1	1550	382
IML TSB-B 140-20-15-17	1	140	20	15,875	127	17	1346,6	5363,3	1650	403
IML TSB-B 140-20-15-18	1	140	20	15,875	127	18	1421,4	5720,9	1700	423
IML TSB-B 140-20-15-19	1	140	20	15,875	127	19	1485,7	6018,9	1750	443
IML TSB-B 140-20-15-20	1	140	20	15,875	127	20	1559,3	6376,4	1800	463
IML TSB-U 140-25-15-2	1	140	25	15,875	127	2	221,2	595,6	210	99
IML TSB-U 140-25-15-3	1	140	25	15,875	127	3	309,2	941	330	124
IML TSB-U 140-25-15-4	1	140	25	15,875	127	4	394,9	1274,6	440	149
IML TSB-U 140-25-15-5	1	140	25	15,875	127	5	478,9	1608,1	550	174
IML TSB-U 140-25-15-6	1	140	25	15,875	127	6	563,4	1953,6	660	199
IML TSB-U 140-25-15-7	1	140	25	15,875	127	7	643,9	2287,1	750	224
IML TSB-B 140-25-15-8	1	140	25	15,875	127	8	709,7	2549,2	850	262
IML TSB-B 140-25-15-9	1	140	25	15,875	127	9	776,8	2823,1	940	291
IML TSB-B 140-25-15-10	1	140	25	15,875	127	10	851,7	3144,7	1050	316
IML TSB-B 140-25-15-11	1	140	25	15,875	127	11	931,9	3502,1	1100	341
IML TSB-B 140-25-15-12	1	140	25	15,875	127	12	1004,7	3823,7	1200	364
IML TSB-B 140-25-15-13	1	140	25	15,875	127	13	1068,4	4097,7	1250	391
IML TSB-B 140-25-15-14	1	140	25	15,875	127	14	1141,8	4431,2	1350	416
IML TSB-B 140-25-15-15	1	140	25	15,875	127	15	1214,4	4764,8	1400	441
IML TSB-B 140-25-15-16	1	140	25	15,875	127	16	1286,3	5098,3	1450	466
IML TSB-U 140-25-19-2	1	140	25	19,05	124,1	2	280,2	697,9	290	101
IML TSB-U 140-25-19-3	1	140	25	19,05	124,1	3	392,6	1106,4	450	126
IML TSB-U 140-25-19-4	1	140	25	19,05	124,1	4	501,2	1497,9	600	151
IML TSB-U 140-25-19-5	1	140	25	19,05	124,1	5	611,3	1906,4	750	176
IML TSB-U 140-25-19-6	1	140	25	19,05	124,1	6	719	2314,9	890	201
IML TSB-U 140-25-19-7	1	140	25	19,05	124,1	7	821	2706,4	1000	226
IML TSB-U 140-25-19-8	1	140	25	19,05	124,1	8	924,6	3114,9	1150	251
IML TSB-B 140-25-19-9	1	140	25	19,05	124,1	9	1003,1	3404,3	1300	293
IML TSB-B 140-25-19-10	1	140	25	19,05	124,1	10	1103,7	3812,8	1400	318
IML TSB-B 140-25-19-11	1	140	25	19,05	124,1	11	1176,9	4085,2	1500	347
IML TSB-B 140-25-19-12	1	140	25	19,05	124,1	12	1275,2	4493,7	1650	362
IML TSB-B 140-25-19-13	1	140	25	19,05	124,1	13	1372,2	4902,2	1750	395
IML TSB-B 140-25-19-14	1	140	25	19,05	124,1	14	1468,2	5310,7	1800	420
IML TSB-B 140-25-19-15	1	140	25	19,05	124,1	15	1563,2	5719,2	1900	445
IML TSB-B 140-25-19-16	1	140	25	19,05	124,1	16	1632,6	5991,6	1950	472

- C_a and C_{oa} : Modified static and dynamic load capacities, calculated according to DIN 69051/4 standard and ISO3408/5. See Technical description catalogue.

- Check with SHUTON-IPIRANGA in case higher loads or more adjusted nut dimensions are required.

- Check external maximum axial force in the two senses.

For the indicated leads, in case C_a and C_{oa} requirements is lower, there is possibility of smaller size balls.

Maximum force (Peak load CO-CO and TR-TR) calculated with the flange/nut clamping in opposite position to the main support of the shaft, with same load type (traction or compression) in both nut and shaft. For same-side clamping, so different type of load, contact SHUTON-IPIRANGA as peak load is lower.

Nut dimensions									Grease quantity TS
$D_{1, std}$	$D_{1, min}$	D_4	D_6	D_5	L_7	L_1	L_8	L_9	$Q_{Gr} [cm^3]$
210	(205)	242 (237)	274 (269)	22	45	40	215 (210)	244,5 (239,5)	full=581
210	(205)	245 (240)	280 (275)	24	45	40	215 (210)	247,5 (242,5)	full=611
210	(205)	245 (240)	280 (275)	24	45	40	215 (210)	247,5 (242,5)	full=644
210	(205)	245 (240)	280 (275)	24	45	40	215 (210)	247,5 (242,5)	full=666
210	(205)	245 (240)	280 (275)	24	45	40	215 (210)	247,5 (242,5)	full=702
210	(205)	245 (240)	280 (275)	24	45	40	215 (210)	247,5 (242,5)	full=730
200		226	252	17,5	30	40	205	228,5	full=107
200		226	252	17,5	30	40	205	228,5	full=138
200		226	252	17,5	30	40	205	228,5	full=171
200		226	252	17,5	30	40	205	228,5	full=205
200		226	252	17,5	30	40	205	228,5	full=239
200		226	252	17,5	30	40	205	228,5	full=276
210	(205)	236 (231)	262 (257)	17,5	45	40	215 (210)	238,5 (233,5)	full=398
210	(205)	236 (231)	262 (257)	17,5	45	40	215 (210)	238,5 (233,5)	full=444
210	(205)	239 (234)	268 (263)	20	45	40	215 (210)	241,5 (236,5)	full=479
210	(205)	239 (234)	268 (263)	20	45	40	215 (210)	241,5 (236,5)	full=509
210	(205)	242 (237)	274 (269)	22	45	40	215 (210)	244,5 (239,5)	full=539
210	(205)	242 (237)	274 (269)	22	45	40	215 (210)	244,5 (239,5)	full=581
210	(205)	242 (237)	274 (269)	22	45	40	215 (210)	244,5 (239,5)	full=610
210	(205)	242 (237)	274 (269)	22	45	40	215 (210)	244,5 (239,5)	full=645
210	(205)	242 (237)	274 (269)	22	45	40	215 (210)	244,5 (239,5)	full=680
210		236	262	17,5	30	40	215	238,5	full=279
210		236	262	17,5	30	40	215	238,5	full=318
210		236	262	17,5	30	40	215	238,5	full=359
210		236	262	17,5	30	40	215	238,5	full=401
210		236	262	17,5	30	40	215	238,5	full=445
210		236	262	17,5	30	40	215	238,5	full=494
210		236	262	17,5	30	40	215	238,5	full=540
220	(215)	252 (247)	284 (279)	22	50	40	225 (220)	254,5 (249,5)	full=578
220	(215)	252 (247)	284 (279)	22	50	40	225 (220)	254,5 (249,5)	full=617
220	(215)	252 (247)	284 (279)	22	50	40	225 (220)	254,5 (249,5)	full=686
220	(215)	255 (250)	290 (285)	24	50	40	225 (220)	257,5 (252,5)	full=683
220	(215)	255 (250)	290 (285)	24	50	40	225 (220)	257,5 (252,5)	full=754
220	(215)	255 (250)	290 (285)	24	50	40	225 (220)	257,5 (252,5)	full=796
220	(215)	255 (250)	290 (285)	24	50	40	225 (220)	257,5 (252,5)	full=837
220	(215)	258 (253)	296 (291)	26	50	40	225 (220)	260,5 (255,5)	full=891

SHUTON-IPIRANGA advises to use the dimensions of the tables, although it is possible to manufacture ball screw with other dimensions. In brackets () second options.

Smaller nut diameters than the first option of the table can reduce the rigidity of the assembly between 5 and 10%. Please consult SHUTON-IPIRANGA.

High Load IML TS Single nut, DN up to 170.000

Ball screw reference	Number of starts	Nominal diameter (mm)	Lead (mm)	Ball Diameter (mm)	Root diameter (mm)	Circuits	Dynamic load capacity	Static load capacity	Peak load CO-CO TR-TR 'TS'	Nut length
	$l/2$	d_0	P_h	D_w	d_2	i	C_a [kN]	C_{oa} [kN]	F_{max} [kN]	$L_{n, std}$ [mm]
IML TSB-U 140-30-19-2	1	140	30	19,05	124,1	2	280	697,4	290	110
IML TSB-U 140-30-19-3	1	140	30	19,05	124,1	3	392,3	1105,7	450	140
IML TSB-U 140-30-19-4	1	140	30	19,05	124,1	4	500,7	1496,9	600	170
IML TSB-U 140-30-19-5	1	140	30	19,05	124,1	5	610,8	1905,1	740	200
IML TSB-U 140-30-19-6	1	140	30	19,05	124,1	6	718,4	2313,4	880	230
IML TSB-U 140-30-19-7	1	140	30	19,05	124,1	7	823,7	2721,6	1000	260
IML TSB-U 140-30-19-8	1	140	30	19,05	124,1	8	923,7	3112,8	1100	290
IML TSB-B 140-30-19-9	1	140	30	19,05	124,1	9	1002,2	3402	1250	340
IML TSB-B 140-30-19-10	1	140	30	19,05	124,1	10	1102,7	3810,2	1350	368
IML TSB-B 140-30-19-11	1	140	30	19,05	124,1	11	1175,9	4082,4	1450	403
IML TSB-B 140-30-19-12	1	140	30	19,05	124,1	12	1274,1	4490,6	1550	433
IML TSB-B 140-30-19-13	1	140	30	19,05	124,1	13	1371	4898,9	1600	463
IML TSB-B 140-30-19-14	1	140	30	19,05	124,1	14	1466,9	5307,1	1700	483
IML TSB(2S)-U 140-32-12-2	2	140	32	12,7	131	2	248,9	800,3	140	117
IML TSB(2S)-U 140-32-12-3	2	140	32	12,7	131	3	344,1	1243,5	220	149
IML TSB(2S)-U 140-32-12-4	2	140	32	12,7	131	4	437,7	1674,4	290	181
IML TSB(2S)-U 140-32-12-5	2	140	32	12,7	131	5	531,6	2117,7	360	213
IML TSB(2S)-B 140-32-12-6	2	140	32	12,7	131	6	611,5	2487	430	253
IML TSB(2S)-B 140-32-12-7	2	140	32	12,7	131	7	688,1	2844,1	490	291
IML TSB(2S)-B 140-32-12-8	2	140	32	12,7	131	8	777	3287,3	550	323
IML TSB(2S)-B 140-32-12-9	2	140	32	12,7	131	9	864,4	3730,6	610	355
IML TSB(2S)-B 140-32-12-10	2	140	32	12,7	131	10	937,4	4087,6	660	387
IML TSB(2S)-B 140-32-12-11	2	140	32	12,7	131	11	1022,4	4530,9	700	419
IML TSB(2S)-B 140-32-12-12	2	140	32	12,7	131	12	1106,3	4974,1	740	451
IML TSB(2S)-B 140-32-12-13	2	140	32	12,7	131	13	1171,2	5294,2	770	485
IML TSB(2S)-B 140-32-12-14	2	140	32	12,7	131	14	1251,6	5725,1	800	517
IML TSB(2S)-B 140-32-12-15	2	140	32	12,7	131	15	1340	6217,6	820	539
IML TSB(2S)-U 140-40-12-2	2	140	40	12,7	131	2	248,4	799,2	140	128
IML TSB(2S)-U 140-40-12-3	2	140	40	12,7	131	3	343,5	1241,8	220	168
IML TSB(2S)-U 140-40-12-4	2	140	40	12,7	131	4	439	1684,4	290	208
IML TSB(2S)-U 140-40-12-5	2	140	40	12,7	131	5	530,7	2114,7	360	248
IML TSB(2S)-B 140-40-12-6	2	140	40	12,7	131	6	610,4	2483,6	420	303
IML TSB(2S)-B 140-40-12-7	2	140	40	12,7	131	7	686,8	2840,1	480	350
IML TSB(2S)-B 140-40-12-8	2	140	40	12,7	131	8	775,6	3282,7	530	388
IML TSB(2S)-B 140-40-12-9	2	140	40	12,7	131	9	862,9	3725,4	570	428
IML TSB(2S)-B 140-40-12-10	2	140	40	12,7	131	10	935,7	4081,9	610	471

- C_a and C_{oa} : Modified static and dynamic load capacities, calculated according to DIN 69051/4 standard and ISO3408/5. See Technical description catalogue.

- Check with SHUTON-IPIRANGA in case higher loads or more adjusted nut dimensions are required.

- Check external maximum axial force in the two senses.

For the indicated leads, in case C_a and C_{oa} requirements is lower, there is possibility of smaller size balls.

Maximum force (Peak load CO-CO and TR-TR) calculated with the flange/nut clamping in opposite position to the main support of the shaft, with same load type (traction or compression) in both nut and shaft. For same-side clamping, so different type of load, contact SHUTON-IPIRANGA as peak load is lower.

Nut dimensions									Grease quantity TS
$D_{1, std}$	$D_{1, min}$	D_4	D_6	D_5	L_7	L_1	L_8	L_9	$Q_{Gr} [cm^3]$
210		236	262	17,5	30	40	215	238,5	full=264
210		236	262	17,5	30	40	215	238,5	full=308
210		236	262	17,5	30	40	215	238,5	full=355
210		236	262	17,5	30	40	215	238,5	full=402
210		236	262	17,5	30	40	215	238,5	full=451
210		236	262	17,5	30	40	215	238,5	full=503
210		236	262	17,5	30	40	215	238,5	full=557
220	(215)	252 (247)	284 (279)	22	50	40	225 (220)	254,5 (249,5)	full=610
220	(215)	252 (247)	284 (279)	22	50	40	225 (220)	254,5 (249,5)	full=647
220	(215)	252 (247)	284 (279)	22	50	40	225 (220)	254,5 (249,5)	full=723
220	(215)	255 (250)	290 (285)	24	50	40	225 (220)	257,5 (252,5)	full=762
220	(215)	255 (250)	290 (285)	24	50	40	225 (220)	257,5 (252,5)	full=809
220	(215)	255 (250)	290 (285)	24	50	40	225 (220)	257,5 (252,5)	full=824
190		216	242	17,5	30	40	195	218,5	full=102
190		216	242	17,5	30	40	195	218,5	full=133
190		216	242	17,5	30	40	195	218,5	full=168
190		216	242	17,5	30	40	195	218,5	full=201
195	(190)	221 (216)	247 (242)	17,5	40	40	200 (195)	223,5 (218,5)	full=312
195	(190)	221 (216)	247 (242)	17,5	40	40	200 (195)	223,5 (218,5)	full=365
195	(190)	221 (216)	247 (242)	17,5	40	40	200 (195)	223,5 (218,5)	full=398
195	(190)	221 (216)	247 (242)	17,5	40	40	200 (195)	223,5 (218,5)	full=430
195	(190)	221 (216)	247 (242)	17,5	40	40	200 (195)	223,5 (218,5)	full=471
195	(190)	221 (216)	247 (242)	17,5	40	40	200 (195)	223,5 (218,5)	full=499
195	(190)	221 (216)	247 (242)	17,5	40	40	200 (195)	223,5 (218,5)	full=533
195	(190)	221 (216)	247 (242)	17,5	40	40	200 (195)	223,5 (218,5)	full=581
195	(190)	221 (216)	247 (242)	17,5	40	40	200 (195)	223,5 (218,5)	full=618
195	(190)	221 (216)	247 (242)	17,5	40	40	200 (195)	223,5 (218,5)	full=615
190		216	242	17,5	30	40	195	218,5	full=113
190		216	242	17,5	30	40	195	218,5	full=152
190		216	242	17,5	30	40	195	218,5	full=195
190		216	242	17,5	30	40	195	218,5	full=238
195	(190)	221 (216)	247 (242)	17,5	40	40	200 (195)	223,5 (218,5)	full=360
195	(190)	221 (216)	247 (242)	17,5	40	40	200 (195)	223,5 (218,5)	full=422
195	(190)	221 (216)	247 (242)	17,5	40	40	200 (195)	223,5 (218,5)	full=458
195	(190)	221 (216)	247 (242)	17,5	40	40	200 (195)	223,5 (218,5)	full=499
195	(190)	221 (216)	247 (242)	17,5	40	40	200 (195)	223,5 (218,5)	full=555

SHUTON-IPIRANGA advises to use the dimensions of the tables, although it is possible to manufacture ball screw with other dimensions. In brackets () second options.

Smaller nut diameters than the first option of the table can reduce the rigidity of the assembly between 5 and 10%. Please consult SHUTON-IPIRANGA.

High Load IML TS Single nut, DN up to 170.000

Ball screw reference	Number of starts	Nominal diameter (mm)	Lead (mm)	Ball Diameter (mm)	Root diameter (mm)	Circuits	Dynamic load capacity	Static load capacity	Peak load CO-CO TR-TR 'TS'	Nut length
	$l/2$	d_0	P_h	D_w	d_2	i	C_a [kN]	C_{oa} [kN]	F_{max} [kN]	$L_{n, std}$ [mm]
IML TSB(2S)-B 140-40-12-11	2	140	40	12,7	131	11	1020,6	4524,5	640	511
IML TSB(2S)-B 140-40-12-12	2	140	40	12,7	131	12	1104,3	4967,1	650	536
IML TSB(2S)-U 140-40-15-2	2	140	40	15,875	127	2	342,2	990,3	350	135
IML TSB(2S)-U 140-40-15-3	2	140	40	15,875	127	3	478,3	1564,7	540	175
IML TSB(2S)-U 140-40-15-4	2	140	40	15,875	127	4	610,8	2119,2	720	215
IML TSB(2S)-U 140-40-15-5	2	140	40	15,875	127	5	744,4	2693,6	890	255
IML TSB(2S)-U 140-40-15-6	2	140	40	15,875	127	6	871,4	3248,1	1050	295
IML TSB(2S)-B 140-40-15-7	2	140	40	15,875	127	7	975,1	3683,9	1200	351
IML TSB(2S)-B 140-40-15-8	2	140	40	15,875	127	8	1097,8	4238,4	1300	389
IML TSB(2S)-B 140-40-15-9	2	140	40	15,875	127	9	1201,6	4694	1400	436
IML TSB(2S)-B 140-40-15-10	2	140	40	15,875	127	10	1317,4	5228,7	1500	476
IML TSB(2S)-B 140-40-15-11	2	140	40	15,875	127	11	1441,4	5822,9	1550	516
IML TSB(2S)-B 140-40-15-12	2	140	40	15,875	127	12	1554,1	6357,6	1600	539
IML TSB(2S)-U 140-50-15-2	2	140	50	15,875	127	2	345,7	1007,9	350	149
IML TSB(2S)-U 140-50-15-3	2	140	50	15,875	127	3	477	1561,2	540	199
IML TSB(2S)-U 140-50-15-4	2	140	50	15,875	127	4	612,8	2134,3	710	249
IML TSB(2S)-U 140-50-15-5	2	140	50	15,875	127	5	742,2	2687,7	870	299
IML TSB(2S)-B 140-50-15-6	2	140	50	15,875	127	6	847,6	3122,4	990	354
IML TSB(2S)-B 140-50-15-7	2	140	50	15,875	127	7	972,3	3675,8	1100	422
IML TSB(2S)-B 140-50-15-8	2	140	50	15,875	127	8	1101,5	4268,6	1200	472
IML TSB(2S)-B 140-50-15-9	2	140	50	15,875	127	9	1198,2	4683,6	1250	510
IML TSB(2S)-U 140-50-19-2	2	140	50	19,05	124,1	2	432,2	1157,8	470	156
IML TSB(2S)-U 140-50-19-3	2	140	50	19,05	124,1	3	605,6	1835,6	720	206
IML TSB(2S)-U 140-50-19-4	2	140	50	19,05	124,1	4	778,8	2513,3	970	256
IML TSB(2S)-U 140-50-19-5	2	140	50	19,05	124,1	5	948,5	3191,1	1150	306
IML TSB(2S)-B 140-50-19-6	2	140	50	19,05	124,1	6	1076,2	3671,1	1350	364
IML TSB(2S)-B 140-50-19-7	2	140	50	19,05	124,1	7	1239,7	4348,9	1500	430
IML TSB(2S)-B 140-50-19-8	2	140	50	19,05	124,1	8	1400	5026,6	1650	480
IML TSB(2S)-B 140-50-19-9	2	140	50	19,05	124,1	9	1521,3	5506,7	1700	522
IML TSB-U 160-20-15-2	1	160	20	15,875	147	2	236,7	694,9	250	90
IML TSB-U 160-20-15-3	1	160	20	15,875	147	3	329,3	1090,2	380	110
IML TSB-U 160-20-15-4	1	160	20	15,875	147	4	419,9	1473,6	510	130
IML TSB-U 160-20-15-5	1	160	20	15,875	147	5	508,9	1857	640	150
IML TSB-U 160-20-15-6	1	160	20	15,875	147	6	598	2252,3	760	170
IML TSB-B 160-20-15-7	1	160	20	15,875	147	7	656,1	2480	860	203
IML TSB-B 160-20-15-8	1	160	20	15,875	147	8	742,5	2875,3	980	223

- C_a and C_{oa} : Modified static and dynamic load capacities, calculated according to DIN 69051/4 standard and ISO3408/5. See Technical description catalogue.

- Check with SHUTON-IPIRANGA in case higher loads or more adjusted nut dimensions are required.

- Check external maximum axial force in the two senses.

For the indicated leads, in case C_a and C_{oa} requirements is lower, there is possibility of smaller size balls.

Maximum force (Peak load CO-CO and TR-TR) calculated with the flange/nut clamping in opposite position to the main support of the shaft, with same load type (traction or compression) in both nut and shaft. For same-side clamping, so different type of load, contact SHUTON-IPIRANGA as peak load is lower.

Nut dimensions									Grease quantity TS
$D_{1, std}$	$D_{1, min}$	D_4	D_6	D_5	L_7	L_1	L_8	L_9	$Q_{Gr} [cm^3]$
195	(190)	221 (216)	247 (242)	17,5	40	40	200 (195)	223,5 (218,5)	full=591
195	(190)	221 (216)	247 (242)	17,5	40	40	200 (195)	223,5 (218,5)	full=601
200		226	252	17,5	30	40	205	228,5	full=156
200		226	252	17,5	30	40	205	228,5	full=208
200		226	252	17,5	30	40	205	228,5	full=265
200		226	252	17,5	30	40	205	228,5	full=320
200		226	252	17,5	30	40	205	228,5	full=381
210	(205)	242 (237)	274 (269)	22	45	40	215 (210)	244,5 (239,5)	full=575
210	(205)	242 (237)	274 (269)	22	45	40	215 (210)	244,5 (239,5)	full=629
210	(205)	242 (237)	274 (269)	22	45	40	215 (210)	244,5 (239,5)	full=712
210	(205)	242 (237)	274 (269)	22	45	40	215 (210)	244,5 (239,5)	full=772
210	(205)	245 (240)	280 (275)	24	45	40	215 (210)	247,5 (242,5)	full=825
210	(205)	245 (240)	280 (275)	24	45	40	215 (210)	247,5 (242,5)	full=831
200		226	252	17,5	30	40	205	228,5	full=163
200		226	252	17,5	30	40	205	228,5	full=228
200		226	252	17,5	30	40	205	228,5	full=292
200		226	252	17,5	30	40	205	228,5	full=360
210	(205)	239 (234)	268 (263)	20	45	40	215 (210)	241,5 (236,5)	full=516
210	(205)	239 (234)	268 (263)	20	45	40	215 (210)	241,5 (236,5)	full=630
210	(205)	242 (237)	274 (269)	22	45	40	215 (210)	244,5 (239,5)	full=695
210	(205)	242 (237)	274 (269)	22	45	40	215 (210)	244,5 (239,5)	full=738
210		236	262	17,5	30	40	215	238,5	full=356
210		236	262	17,5	30	40	215	238,5	full=435
210		236	262	17,5	30	40	215	238,5	full=514
210		236	262	17,5	30	40	215	238,5	full=598
220	(215)	252 (247)	284 (279)	22	50	40	225 (220)	254,5 (249,5)	full=692
220	(215)	252 (247)	284 (279)	22	50	40	225 (220)	254,5 (249,5)	full=830
220	(215)	255 (250)	290 (285)	24	50	40	225 (220)	257,5 (252,5)	full=909
220	(215)	255 (250)	290 (285)	24	50	40	225 (220)	257,5 (252,5)	full=983
220		246	272	17,5	30	40	225	248,5	full=119
220		246	272	17,5	30	40	225	248,5	full=149
220		246	272	17,5	30	40	225	248,5	full=181
220		246	272	17,5	30	40	225	248,5	full=215
220		246	272	17,5	30	40	225	248,5	full=248
230		256	282	17,5	45	40	235	258,5	full=405
230		256	282	17,5	45	40	235	258,5	full=436

SHUTON-IPIRANGA advises to use the dimensions of the tables, although it is possible to manufacture ball screw with other dimensions. In brackets () second options.

Smaller nut diameters than the first option of the table can reduce the rigidity of the assembly between 5 and 10%. Please consult SHUTON-IPIRANGA.

High Load IML TS Single nut, DN up to 170.000

Ball screw reference	Number of starts	Nominal diameter (mm)	Lead (mm)	Ball Diameter (mm)	Root diameter (mm)	Circuits	Dynamic load capacity	Static load capacity	Peak load CO-CO TR-TR 'TS'	Nut length
	$l/2$	d_0	P_h	D_w	d_2	i	C_a [kN]	C_{oa} [kN]	F_{max} [kN]	$L_{n,std}$ [mm]
IML TSB-B 160-20-15-9	1	160	20	15,875	147	9	827,3	3270,7	1100	243
IML TSB-B 160-20-15-10	1	160	20	15,875	147	10	890,8	3546,2	1200	264
IML TSB-B 160-20-15-11	1	160	20	15,875	147	11	971,5	3929,6	1300	284
IML TSB-B 160-20-15-12	1	160	20	15,875	147	12	1058,8	4360,9	1450	304
IML TSB-B 160-20-15-13	1	160	20	15,875	147	13	1125,8	4672,4	1500	325
IML TSB-B 160-20-15-14	1	160	20	15,875	147	14	1199,8	5031,8	1600	345
IML TSB-B 160-20-15-15	1	160	20	15,875	147	15	1282,5	5451,1	1700	363
IML TSB-U 160-25-15-2	1	160	25	15,875	147	2	236,5	694,6	250	99
IML TSB-U 160-25-15-3	1	160	25	15,875	147	3	329,1	1089,8	380	124
IML TSB-U 160-25-15-4	1	160	25	15,875	147	4	419,7	1473	510	149
IML TSB-U 160-25-15-5	1	160	25	15,875	147	5	508,6	1856,2	630	174
IML TSB-U 160-25-15-6	1	160	25	15,875	147	6	597,7	2251,4	750	199
IML TSB-B 160-25-15-7	1	160	25	15,875	147	7	655,8	2478,9	850	241
IML TSB-B 160-25-15-8	1	160	25	15,875	147	8	742,1	2874,1	970	266
IML TSB-B 160-25-15-9	1	160	25	15,875	147	9	826,9	3269,3	1100	291
IML TSB-B 160-25-15-10	1	160	25	15,875	147	10	890,3	3544,7	1150	318
IML TSB-B 160-25-15-11	1	160	25	15,875	147	11	970,9	3927,9	1250	343
IML TSB-B 160-25-15-12	1	160	25	15,875	147	12	1058,2	4359,1	1350	366
IML TSB-B 160-25-15-13	1	160	25	15,875	147	13	1125,2	4670,4	1450	392
IML TSB-B 160-25-15-14	1	160	25	15,875	147	14	1199,1	5029,7	1550	417
IML TSB-B 160-25-15-15	1	160	25	15,875	147	15	1281,7	5448,8	1600	442
IML TSB-U 160-25-19-2	1	160	25	19,05	144,1	2	298,1	805,1	330	102
IML TSB-U 160-25-19-3	1	160	25	19,05	144,1	3	415,8	1267,6	510	127
IML TSB-U 160-25-19-4	1	160	25	19,05	144,1	4	533,6	1730,1	690	152
IML TSB-U 160-25-19-5	1	160	25	19,05	144,1	5	649,1	2192,6	860	177
IML TSB-U 160-25-19-6	1	160	25	19,05	144,1	6	762	2655,1	1000	202
IML TSB-U 160-25-19-7	1	160	25	19,05	144,1	7	872,6	3117,6	1150	227
IML TSB-B 160-25-19-8	1	160	25	19,05	144,1	8	959,1	3460,2	1350	268
IML TSB-B 160-25-19-9	1	160	25	19,05	144,1	9	1044,5	3802,8	1450	297
IML TSB-B 160-25-19-10	1	160	25	19,05	144,1	10	1150,4	4265,3	1600	322
IML TSB-B 160-25-19-11	1	160	25	19,05	144,1	11	1254,7	4727,8	1750	347
IML TSB-B 160-25-19-12	1	160	25	19,05	144,1	12	1357,7	5190,3	1850	362
IML TSB-B 160-25-19-13	1	160	25	19,05	144,1	13	1441,7	5550,1	2000	397
IML TSB-B 160-25-19-14	1	160	25	19,05	144,1	14	1545,5	6029,7	2100	422
IML TSB-B 160-25-19-15	1	160	25	19,05	144,1	15	1648,1	6509,3	2200	447
IML TSB-B 160-25-19-16	1	160	25	19,05	144,1	16	1738,3	6920,5	2250	472

- C_a and C_{oa} : Modified static and dynamic load capacities, calculated according to DIN 69051/4 standard and ISO3408/5. See Technical description catalogue.

- Check with SHUTON-IPIRANGA in case higher loads or more adjusted nut dimensions are required.

- Check external maximum axial force in the two senses.

For the indicated leads, in case C_a and C_{oa} requirements is lower, there is possibility of smaller size balls.

Maximum force (Peak load CO-CO and TR-TR) calculated with the flange/nut clamping in opposite position to the main support of the shaft, with same load type (traction or compression) in both nut and shaft. For same-side clamping, so different type of load, contact SHUTON-IPIRANGA as peak load is lower.

Nut dimensions									Grease quantity TS
$D_{1, std}$	$D_{1, min}$	D_4	D_6	D_5	L_7	L_1	L_8	L_9	$Q_{Gr} [cm^3]$
230		259	288	20	45	40	235	261,5	full=466
230		262	294	22	45	40	235	264,5	full=508
230		262	294	22	45	40	235	264,5	full=541
230		262	294	22	45	40	235	264,5	full=569
230		262	294	22	45	40	235	264,5	full=610
230		265	300	24	45	40	235	267,5	full=641
230		265	300	24	45	40	235	267,5	full=664
220		246	272	17,5	30	40	225	248,5	full=120
220		246	272	17,5	30	40	225	248,5	full=156
220		246	272	17,5	30	40	225	248,5	full=194
220		246	272	17,5	30	40	225	248,5	full=233
220		246	272	17,5	30	40	225	248,5	full=271
230		256	282	17,5	45	40	235	258,5	full=430
230		256	282	17,5	45	40	235	258,5	full=466
230		259	288	20	45	40	235	261,5	full=502
230		259	288	20	45	40	235	261,5	full=552
230		262	294	22	45	40	235	264,5	full=591
230		262	294	22	45	40	235	264,5	full=618
230		262	294	22	45	40	235	264,5	full=664
230		265	300	24	45	40	235	267,5	full=700
230		265	300	24	45	40	235	267,5	full=736
230		256	282	17,5	30	40	235	258,5	full=323
230		256	282	17,5	30	40	235	258,5	full=367
230		256	282	17,5	30	40	235	258,5	full=412
230		256	282	17,5	30	40	235	258,5	full=462
230		256	282	17,5	30	40	235	258,5	full=511
230		256	282	17,5	30	40	235	258,5	full=563
240	(235)	272 (267)	304 (299)	22	50	40	245 (240)	274,5 (269,5)	full=606
240	(235)	272 (267)	304 (299)	22	50	40	245 (240)	274,5 (269,5)	full=682
240	(235)	275 (270)	310 (305)	24	50	40	245 (240)	277,5 (272,5)	full=721
240	(235)	275 (270)	310 (305)	24	50	40	245 (240)	277,5 (272,5)	full=769
240	(235)	275 (270)	310 (305)	24	50	40	245 (240)	277,5 (272,5)	full=774
240	(235)	278 (273)	316 (311)	26	50	40	245 (240)	280,5 (275,5)	full=868
240	(235)	278 (273)	316 (311)	26	50	40	245 (240)	280,5 (275,5)	full=915
240	(235)	278 (273)	316 (311)	26	50	40	245 (240)	280,5 (275,5)	full=962
240	(235)	282 (277)	324 (319)	29	50	40	245 (240)	284,5 (279,5)	full=1009

SHUTON-IPIRANGA advises to use the dimensions of the tables, although it is possible to manufacture ball screw with other dimensions. In brackets () second options.

Smaller nut diameters than the first option of the table can reduce the rigidity of the assembly between 5 and 10%. Please consult SHUTON-IPIRANGA.

High Load IML TS Single nut, DN up to 170.000

Ball screw reference	Number of starts	Nominal diameter (mm)	Lead (mm)	Ball Diameter (mm)	Root diameter (mm)	Circuits	Dynamic load capacity	Static load capacity	Peak load CO-CO TR-TR 'TS'	Nut length
	$l/2$	d_0	P_h	D_w	d_2	i	C_a [kN]	C_{oa} [kN]	F_{max} [kN]	$L_{n, std}$ [mm]
IML TSB-U 160-30-19-2	1	160	30	19,05	144,1	2	302,1	821,8	330	111
IML TSB-U 160-30-19-3	1	160	30	19,05	144,1	3	419,2	1284,1	510	141
IML TSB-U 160-30-19-4	1	160	30	19,05	144,1	4	536,8	1746,3	690	171
IML TSB-U 160-30-19-5	1	160	30	19,05	144,1	5	652	2208,6	850	201
IML TSB-U 160-30-19-6	1	160	30	19,05	144,1	6	764,7	2670,9	1000	231
IML TSB-U 160-30-19-7	1	160	30	19,05	144,1	7	875,2	3133,1	1150	261
IML TSB-B 160-30-19-8	1	160	30	19,05	144,1	8	964,8	3492,7	1300	310
IML TSB-B 160-30-19-9	1	160	30	19,05	144,1	9	1053,2	3852,2	1450	345
IML TSB-B 160-30-19-10	1	160	30	19,05	144,1	10	1158,8	4314,5	1550	363
IML TSB-B 160-30-19-11	1	160	30	19,05	144,1	11	1263	4776,7	1700	403
IML TSB-B 160-30-19-12	1	160	30	19,05	144,1	12	1365,8	5239	1800	433
IML TSB-B 160-30-19-13	1	160	30	19,05	144,1	13	1440,8	5547,2	1850	466
IML TSB-B 160-30-19-14	1	160	30	19,05	144,1	14	1544,5	6026,6	1900	488

- C_a and C_{oa} : Modified static and dynamic load capacities, calculated according to DIN 69051/4 standard and ISO3048/5. See Technical description catalogue.
- Check with SHUTON-IPIRANGA in case higher loads or more adjusted nut dimensions are required.
- Check external maximum axial force in the two senses.

For the indicated leads, in case C_a and C_{oa} requirements is lower, there is possibility of smaller size balls.

Maximum force (Peak load CO-CO and TR-TR) calculated with the flange/nut clamping in opposite position to the main support of the shaft, with same load type (traction or compression) in both nut and shaft. For same-side clamping, so different type of load, contact SHUTON-IPIRANGA as peak load is lower.

Nut dimensions									Grease quantity TS
$D_{1, std}$	$D_{1, min}$	D_4	D_6	D_5	L_7	L_1	L_8	L_9	$Q_G [cm^3]$
230		256	282	17,5	30	40	235	258,5	full=303
230		256	282	17,5	30	40	235	258,5	full=353
230		256	282	17,5	30	40	235	258,5	full=404
230		256	282	17,5	30	40	235	258,5	full=460
230		256	282	17,5	30	40	235	258,5	full=515
230		256	282	17,5	30	40	235	258,5	full=573
240	(235)	272 (267)	304 (299)	22	50	40	245 (240)	274,5 (269,5)	full=630
240	(235)	272 (267)	304 (299)	22	50	40	245 (240)	274,5 (269,5)	full=712
240	(235)	275 (270)	310 (305)	24	50	40	245 (240)	277,5 (272,5)	full=713
240	(235)	275 (270)	310 (305)	24	50	40	245 (240)	277,5 (272,5)	full=803
240	(235)	275 (270)	310 (305)	24	50	40	245 (240)	277,5 (272,5)	full=857
240	(235)	275 (270)	310 (305)	24	50	40	245 (240)	277,5 (272,5)	full=933
240	(235)	275 (270)	310 (305)	24	50	40	245 (240)	277,5 (272,5)	full=957

SHUTON-IPIRANGA advises to use the dimensions of the tables, although it is possible to manufacture ball screw with other dimensions. In brackets () second options.

Smaller nut diameters than the first option of the table can reduce the rigidity of the assembly between 5 and 10%. Please consult SHUTON-IPIRANGA.

High Load HDL TS Single nut, DN up to 110.000

Ball screw reference	Number of starts	Nominal diameter (mm)	Lead (mm)	Ball Diameter (mm)	Root diameter (mm)	Circuits	Dynamic load capacity	Static load capacity	Peak load CO-CO TR-TR 'TS'	Nut length
	$1/2$	d_0	P_h	D_w	d_2	i	C_a [kN]	C_{oa} [kN]	F_{max} [kN]	$L_{n, std}$ [mm]
HDL TSB-B 63-16-12-2	1	63	16	12,7	53	2	112,8	206	45	75
HDL TSB-B 63-16-12-3	1	63	16	12,7	53	3	162,6	340,7	75	91
HDL TSB-B 63-16-12-4	1	63	16	12,7	53	4	209,4	467,5	100	107
HDL TSB-B 63-16-12-5	1	63	16	12,7	53	5	255,2	594,3	130	123
HDL TSB-B 63-16-12-6	1	63	16	12,7	53	6	302,2	729	150	139
HDL TSB-B 63-16-12-7	1	63	16	12,7	53	7	346	855,7	180	155
HDL TSB-B 63-16-12-8	1	63	16	12,7	53	8	376,3	935	200	179
HDL TSB-B 63-16-12-9	1	63	16	12,7	53	9	418,9	1061,7	230	195
HDL TSB-B 63-16-12-10	1	63	16	12,7	53	10	460,7	1188,5	250	211
HDL TSB-B 63-16-12-11	1	63	16	12,7	53	11	506	1331,1	270	227
HDL TSB-B 63-16-12-12	1	63	16	12,7	53	12	546,7	1457,9	300	243
HDL TSB-B 63-16-12-13	1	63	16	12,7	53	13	586,9	1584,7	320	259
HDL TSB-B 63-16-12-14	1	63	16	12,7	53	14	626,6	1711,5	340	271
HDL TSB-B 63-20-12-2	1	63	20	12,7	53	2	112,5	205,7	45	83
HDL TSB-B 63-20-12-3	1	63	20	12,7	53	3	162,2	340,1	75	103
HDL TSB-B 63-20-12-4	1	63	20	12,7	53	4	208,9	466,7	100	123
HDL TSB-B 63-20-12-5	1	63	20	12,7	53	5	256,9	601,2	130	143
HDL TSB-B 63-20-12-6	1	63	20	12,7	53	6	301,5	727,7	150	163
HDL TSB-B 63-20-12-7	1	63	20	12,7	53	7	345,2	854,3	180	183
HDL TSB-B 63-20-12-8	1	63	20	12,7	53	8	375,5	933,4	200	213
HDL TSB-B 63-20-12-9	1	63	20	12,7	53	9	418	1060	220	233
HDL TSB-B 63-20-12-10	1	63	20	12,7	53	10	463,8	1202,4	250	253
HDL TSB-B 63-20-12-11	1	63	20	12,7	53	11	504,9	1328,9	270	268
HDL TSB-B 63-20-15-2	1	63	20	15,875	50,1	2	149,6	253,8	60	89
HDL TSB-B 63-20-15-3	1	63	20	15,875	50,1	3	215,2	418,8	100	109
HDL TSB-B 63-20-15-4	1	63	20	15,875	50,1	4	280,2	583,9	140	129
HDL TSB-B 63-20-15-5	1	63	20	15,875	50,1	5	343,5	748,9	170	149
HDL TSB-B 63-20-15-6	1	63	20	15,875	50,1	6	409,1	926,5	210	169
HDL TSB-B 63-20-15-7	1	63	20	15,875	50,1	7	469,5	1091,5	240	189
HDL TSB-B 63-20-15-8	1	63	20	15,875	50,1	8	528,8	1256,5	270	209
HDL TSB-B 63-20-15-9	1	63	20	15,875	50,1	9	587,1	1421,6	300	229
HDL TSB-B 63-20-15-10	1	63	20	15,875	50,1	10	644,5	1586,6	320	249
HDL TSB-B 63-20-15-11	1	63	20	15,875	50,1	11	680,6	1675,4	370	274
HDL TSB-B 63-25-12-2	1	63	25	12,7	53	2	112,2	205,1	45	93
HDL TSB-B 63-25-12-3	1	63	25	12,7	53	3	161,7	339,3	75	118
HDL TSB-B 63-25-12-4	1	63	25	12,7	53	4	208,2	465,5	100	143

- C_a and C_{oa} : Modified static and dynamic load capacities, calculated according to DIN 69051/4 standard and ISO3408/5. See Technical description catalogue.

- Check with SHUTON-IPIRANGA in case higher loads or more adjusted nut dimensions are required.

- Check external maximum axial force in the two senses.

For the indicated leads, in case C_a and C_{oa} requirements is lower, there is possibility of smaller size balls.

Maximum force (Peak load CO-CO and TR-TR) calculated with the flange/nut clamping in opposite position to the main support of the shaft, with same load type (traction or compression) in both nut and shaft. For same-side clamping, so different type of load, contact SHUTON-IPIRANGA as peak load is lower.

Nut dimensions									Grease quantity TS
$D_{1, std}$	$D_{1, min}$	D_4	D_6	D_5	L_7	L_1	L_8	L_9	$Q_{Gr} [cm^3]$
110		130	150	13,5	40	25	115	132,5	full=79
110		130	150	13,5	40	25	115	132,5	full=90
110		130	150	13,5	40	25	115	132,5	full=102
110		130	150	13,5	40	25	115	132,5	full=116
110		130	150	13,5	40	25	115	132,5	full=129
110		130	150	13,5	40	25	115	132,5	full=143
110		130	150	13,5	40	25	115	132,5	full=171
110		130	150	13,5	40	25	115	132,5	full=184
110		130	150	13,5	40	25	115	132,5	full=198
110		130	150	13,5	40	25	115	132,5	full=211
110		130	150	13,5	40	25	115	132,5	full=225
110		130	150	13,5	40	25	115	132,5	full=238
110		130	150	13,5	40	25	115	132,5	full=246
110		130	150	13,5	40	25	115	132,5	full=77
110		130	150	13,5	40	25	115	132,5	full=91
110		130	150	13,5	40	25	115	132,5	full=106
110		130	150	13,5	40	25	115	132,5	full=121
110		130	150	13,5	40	25	115	132,5	full=138
110		130	150	13,5	40	25	115	132,5	full=155
110		130	150	13,5	40	25	115	132,5	full=186
110		130	150	13,5	40	25	115	132,5	full=202
110		130	150	13,5	40	25	115	132,5	full=216
110		130	150	13,5	40	25	115	132,5	full=226
120		140	160	13,5	45	25	125	142,5	full=121
120		140	160	13,5	45	25	125	142,5	full=140
120		140	160	13,5	45	25	125	142,5	full=161
120		140	160	13,5	45	25	125	142,5	full=180
120		140	160	13,5	45	25	125	142,5	full=199
120		140	160	13,5	45	25	125	142,5	full=222
120		140	160	13,5	45	25	125	142,5	full=246
120		140	160	13,5	45	25	125	142,5	full=271
120		140	160	13,5	45	25	125	142,5	full=298
120		140	160	13,5	45	25	125	142,5	full=318
110		130	150	13,5	40	25	115	132,5	full=79
110		130	150	13,5	40	25	115	132,5	full=96
110		130	150	13,5	40	25	115	132,5	full=114

SHUTON-IPIRANGA advises to use the dimensions of the tables, although it is possible to manufacture ball screw with other dimensions. In brackets () second options.

Smaller nut diameters than the first option of the table can reduce the rigidity of the assembly between 5 and 10%. Please consult SHUTON-IPIRANGA.

High Load HDL TS Single nut, DN up to 110.000

Ball screw reference	Number of starts	Nominal diameter (mm)	Lead (mm)	Ball Diameter (mm)	Root diameter (mm)	Circuits	Dynamic load capacity	Static load capacity	Peak load CO-CO TR-TR 'TS'	Nut length
	$l/2$	d_0	P_h	D_w	d_2	i	C_a [kN]	C_{oa} [kN]	F_{max} [kN]	L_{nstd} [mm]
HDL TSB-B 63-25-12-5	1	63	25	12,7	53	5	256	599,6	130	168
HDL TSB-B 63-25-12-6	1	63	25	12,7	53	6	300,5	725,9	150	193
HDL TSB-B 63-25-12-7	1	63	25	12,7	53	7	346,2	860	170	218
HDL TSB-B 63-25-12-8	1	63	25	12,7	53	8	374,3	931	200	256
HDL TSB-B 63-25-12-9	1	63	25	12,7	53	9	420,7	1073	220	274
HDL TSB-B 63-25-15-2	1	63	25	15,875	50,1	2	149,1	253,2	60	99
HDL TSB-B 63-25-15-3	1	63	25	15,875	50,1	3	214,5	417,8	100	124
HDL TSB-B 63-25-15-4	1	63	25	15,875	50,1	4	279,2	582,4	130	149
HDL TSB-B 63-25-15-5	1	63	25	15,875	50,1	5	346,2	759,6	170	174
HDL TSB-B 63-25-15-6	1	63	25	15,875	50,1	6	407,7	924,2	210	199
HDL TSB-B 63-25-15-7	1	63	25	15,875	50,1	7	468	1088,7	240	224
HDL TSB-B 63-25-15-8	1	63	25	15,875	50,1	8	527	1253,3	260	249
HDL TSB-B 63-30-12-2	1	63	30	12,7	53	2	111,7	204,5	45	103
HDL TSB-B 63-30-12-3	1	63	30	12,7	53	3	161	338,2	75	133
HDL TSB-B 63-30-12-4	1	63	30	12,7	53	4	207,4	464	100	163
HDL TSB-B 63-30-12-5	1	63	30	12,7	53	5	255	597,7	130	193
HDL TSB-B 63-30-12-6	1	63	30	12,7	53	6	299,3	723,6	150	223
HDL TSB-B 63-30-12-7	1	63	30	12,7	53	7	344,8	857,3	170	253
HDL TSB-B 63-30-15-2	1	63	30	15,875	50,1	2	148,5	252,4	60	109
HDL TSB-B 63-30-15-3	1	63	30	15,875	50,1	3	213,7	416,5	100	139
HDL TSB-B 63-30-15-4	1	63	30	15,875	50,1	4	282,1	593,2	140	169
HDL TSB-B 63-30-15-5	1	63	30	15,875	50,1	5	344,8	757,2	170	199
HDL TSB-B 63-30-15-6	1	63	30	15,875	50,1	6	406,1	921,3	200	229
HDL TSB-B 63-30-15-7	1	63	30	15,875	50,1	7	466,1	1085,4	230	259
HDL TSB(2S)-B 63-32-12-2	2	63	32	12,7	53	2	177,4	353,4	75	109
HDL TSB(2S)-B 63-32-12-3	2	63	32	12,7	53	3	249,4	562,9	120	141
HDL TSB(2S)-B 63-32-12-4	2	63	32	12,7	53	4	324,8	785,4	170	173
HDL TSB(2S)-B 63-32-12-5	2	63	32	12,7	53	5	394,9	994,8	210	205
HDL TSB(2S)-B 63-32-12-6	2	63	32	12,7	53	6	466,9	1217,4	250	237
HDL TSB(2S)-B 63-32-12-7	2	63	32	12,7	53	7	510,9	1335,2	270	276
HDL TSB(2S)-U 63-40-12-2	2	63	40	12,7	53	2	175,9	351,1	75	127
HDL TSB(2S)-U 63-40-12-3	2	63	40	12,7	53	3	247,3	559,2	120	167
HDL TSB(2S)-U 63-40-12-4	2	63	40	12,7	53	4	322,1	780,3	160	207
HDL TSB(2S)-U 63-40-12-5	2	63	40	12,7	53	5	395	1001,4	210	247
HDL TSB(2S)-B 63-40-15-2	2	63	40	15,875	50,1	2	228	417,4	100	131
HDL TSB(2S)-B 63-40-15-3	2	63	40	15,875	50,1	3	334,7	709,6	170	171

- C_a and C_{oa} : Modified static and dynamic load capacities, calculated according to DIN 69051/4 standard and ISO3408/5. See Technical description catalogue.

- Check with SHUTON-IPIRANGA in case higher loads or more adjusted nut dimensions are required.

- Check external maximum axial force in the two senses.

For the indicated leads, in case C_a and C_{oa} requirements is lower, there is possibility of smaller size balls.

Maximum force (Peak load CO-CO and TR-TR) calculated with the flange/nut clamping in opposite position to the main support of the shaft, with same load type (traction or compression) in both nut and shaft. For same-side clamping, so different type of load, contact SHUTON-IPIRANGA as peak load is lower.

Nut dimensions									Grease quantity TS
$D_{1, std}$	$D_{1, min}$	D_4	D_6	D_5	L_7	L_1	L_8	L_9	$Q_G [cm^3]$
110		130	150	13,5	40	25	115	132,5	full=132
110		130	150	13,5	40	25	115	132,5	full=152
110		130	150	13,5	40	25	115	132,5	full=171
110		130	150	13,5	40	25	115	132,5	full=209
110		130	150	13,5	40	25	115	132,5	full=216
120		140	160	13,5	45	25	125	142,5	full=118
120		140	160	13,5	45	25	125	142,5	full=140
120		140	160	13,5	45	25	125	142,5	full=165
120		140	160	13,5	45	25	125	142,5	full=185
120		140	160	13,5	45	25	125	142,5	full=210
120		140	160	13,5	45	25	125	142,5	full=237
120		140	160	13,5	45	25	125	142,5	full=263
110		130	150	13,5	40	25	115	132,5	full=82
110		130	150	13,5	40	25	115	132,5	full=102
110		130	150	13,5	40	25	115	132,5	full=123
110		130	150	13,5	40	25	115	132,5	full=144
110		130	150	13,5	40	25	115	132,5	full=168
110		130	150	13,5	40	25	115	132,5	full=190
120		140	160	13,5	45	25	125	142,5	full=118
120		140	160	13,5	45	25	125	142,5	full=144
120		140	160	13,5	45	25	125	142,5	full=170
120		140	160	13,5	45	25	125	142,5	full=196
120		140	160	13,5	45	25	125	142,5	full=224
120		140	160	13,5	45	25	125	142,5	full=254
110		130	150	13,5	40	25	115	132,5	full=108
110		130	150	13,5	40	25	115	132,5	full=133
110		130	150	13,5	40	25	115	132,5	full=156
110		130	150	13,5	40	25	115	132,5	full=183
110		130	150	13,5	40	25	115	132,5	full=211
110		130	150	13,5	40	25	115	132,5	full=259
110		130	150	13,5	25	25	115	132,5	full=75
110		130	150	13,5	25	25	115	132,5	full=106
110		130	150	13,5	25	25	115	132,5	full=134
110		130	150	13,5	25	25	115	132,5	full=164
120		140	160	13,5	45	25	125	142,5	full=172
120		140	160	13,5	45	25	125	142,5	full=207

SHUTON-IPIRANGA advises to use the dimensions of the tables, although it is possible to manufacture ball screw with other dimensions. In brackets () second options.

Smaller nut diameters than the first option of the table can reduce the rigidity of the assembly between 5 and 10%. Please consult SHUTON-IPIRANGA.

High Load HDL TS Single nut, DN up to 110.000

Ball screw reference	Number of starts	Nominal diameter (mm)	Lead (mm)	Ball Diameter (mm)	Root diameter (mm)	Circuits	Dynamic load capacity	Static load capacity	Peak load CO-CO TR-TR 'TS'	Nut length
	$l/2$	d_0	P_h	D_w	d_2	i	C_a [kN]	C_{oa} [kN]	F_{max} [kN]	$L_{n, std}$ [mm]
HDL TSB(2S)-B 63-40-15-4	2	63	40	15,875	50,1	4	433,3	980,9	220	211
HDL TSB(2S)-B 63-40-15-5	2	63	40	15,875	50,1	5	529,6	1252,2	280	251
HDL TSB(2S)-U 63-50-12-2	2	63	50	12,7	53	2	173,7	347,6	75	137
HDL TSB(2S)-U 63-50-12-3	2	63	50	12,7	53	3	247,8	566,5	120	187
HDL TSB(2S)-U 63-50-12-4	2	63	50	12,7	53	4	321,4	785,4	160	237
HDL TSB(2S)-B 63-50-15-2	2	63	50	15,875	50,1	2	225,1	413,3	100	149
HDL TSB(2S)-B 63-50-15-3	2	63	50	15,875	50,1	3	330,5	702,6	160	199
HDL TSB(2S)-B 63-50-15-4	2	63	50	15,875	50,1	4	427,7	971,2	210	249
HDL TSB-B 70-16-12-2	1	70	16	12,7	60	2	122,3	239,5	50	75
HDL TSB-B 70-16-12-3	1	70	16	12,7	60	3	172,4	383,3	85	91
HDL TSB-B 70-16-12-4	1	70	16	12,7	60	4	222,4	527	110	107
HDL TSB-B 70-16-12-5	1	70	16	12,7	60	5	271,3	670,7	140	123
HDL TSB-B 70-16-12-6	1	70	16	12,7	60	6	319,1	814,4	170	139
HDL TSB-B 70-16-12-7	1	70	16	12,7	60	7	365,9	958,1	200	155
HDL TSB-B 70-16-12-8	1	70	16	12,7	60	8	399,7	1054	230	179
HDL TSB-B 70-16-12-9	1	70	16	12,7	60	9	445,1	1197,7	250	195
HDL TSB-B 70-16-12-10	1	70	16	12,7	60	10	489,8	1341,4	280	211
HDL TSB-B 70-16-12-11	1	70	16	12,7	60	11	533,8	1485,1	310	227
HDL TSB-B 70-16-12-12	1	70	16	12,7	60	12	577,2	1628,8	330	243
HDL TSB-B 70-16-12-13	1	70	16	12,7	60	13	620,2	1772,6	350	255
HDL TSB-B 70-16-12-14	1	70	16	12,7	60	14	662,6	1916,3	380	271
HDL TSB-B 70-20-12-2	1	70	20	12,7	60	2	122,1	239,2	50	83
HDL TSB-B 70-20-12-3	1	70	20	12,7	60	3	172,1	382,7	85	103
HDL TSB-B 70-20-12-4	1	70	20	12,7	60	4	222	526,3	110	123
HDL TSB-B 70-20-12-5	1	70	20	12,7	60	5	270,8	669,8	140	143
HDL TSB-B 70-20-12-6	1	70	20	12,7	60	6	318,5	813,3	170	163
HDL TSB-B 70-20-12-7	1	70	20	12,7	60	7	365,2	956,8	200	183
HDL TSB-B 70-20-12-8	1	70	20	12,7	60	8	399	1052,5	220	213
HDL TSB-B 70-20-12-9	1	70	20	12,7	60	9	444,3	1196	250	233
HDL TSB-B 70-20-12-10	1	70	20	12,7	60	10	488,9	1339,6	280	253
HDL TSB-B 70-20-12-11	1	70	20	12,7	60	11	532,8	1483,1	300	273
HDL TSB-B 70-20-15-2	1	70	20	15,875	57,1	2	163	294,8	70	89
HDL TSB-B 70-20-15-3	1	70	20	15,875	57,1	3	230,6	474,3	110	109
HDL TSB-B 70-20-15-4	1	70	20	15,875	57,1	4	301,8	666,6	160	129
HDL TSB-B 70-20-15-5	1	70	20	15,875	57,1	5	367,5	846	190	149
HDL TSB-B 70-20-15-6	1	70	20	15,875	57,1	6	435,3	1038,3	230	169

- C_a and C_{oa} : Modified static and dynamic load capacities, calculated according to DIN 69051/4 standard and ISO3408/5. See Technical description catalogue.

- Check with SHUTON-IPIRANGA in case higher loads or more adjusted nut dimensions are required.

- Check external maximum axial force in the two senses.

For the indicated leads, in case C_a and C_{oa} requirements is lower, there is possibility of smaller size balls.

Maximum force (Peak load CO-CO and TR-TR) calculated with the flange/nut clamping in opposite position to the main support of the shaft, with same load type (traction or compression) in both nut and shaft. For same-side clamping, so different type of load, contact SHUTON-IPIRANGA as peak load is lower.

Nut dimensions									Grease quantity TS
$D_{1, std}$	$D_{1, min}$	D_4	D_6	D_5	L_7	L_1	L_8	L_9	$Q_{Gr} [cm^3]$
120		140	160	13,5	45	25	125	142,5	full=250
120		140	160	13,5	45	25	125	142,5	full=289
110		130	150	13,5	25	25	115	132,5	full=82
110		130	150	13,5	25	25	115	132,5	full=117
110		130	150	13,5	25	25	115	132,5	full=152
120		140	160	13,5	45	25	125	142,5	full=177
120		140	160	13,5	45	25	125	142,5	full=219
120		140	160	13,5	45	25	125	142,5	full=269
120		140	160	13,5	40	25	125	142,5	full=85
120		140	160	13,5	40	25	125	142,5	full=99
120		140	160	13,5	40	25	125	142,5	full=113
120		140	160	13,5	40	25	125	142,5	full=127
120		140	160	13,5	40	25	125	142,5	full=142
120		140	160	13,5	40	25	125	142,5	full=158
120		140	160	13,5	40	25	125	142,5	full=189
120		140	160	13,5	40	25	125	142,5	full=203
120		140	160	13,5	40	25	125	142,5	full=217
120		140	160	13,5	40	25	125	142,5	full=232
120		140	160	13,5	40	25	125	142,5	full=248
120		140	160	13,5	40	25	125	142,5	full=256
120		140	160	13,5	40	25	125	142,5	full=271
120		140	160	13,5	40	25	125	142,5	full=84
120		140	160	13,5	40	25	125	142,5	full=100
120		140	160	13,5	40	25	125	142,5	full=117
120		140	160	13,5	40	25	125	142,5	full=134
120		140	160	13,5	40	25	125	142,5	full=152
120		140	160	13,5	40	25	125	142,5	full=170
120		140	160	13,5	40	25	125	142,5	full=206
120		140	160	13,5	40	25	125	142,5	full=223
120		140	160	13,5	40	25	125	142,5	full=240
120		140	160	13,5	40	25	125	142,5	full=257
130		150	170	13,5	45	25	135	152,5	full=132
130		150	170	13,5	45	25	135	152,5	full=155
130		150	170	13,5	45	25	135	152,5	full=175
130		150	170	13,5	45	25	135	152,5	full=198
130		150	170	13,5	45	25	135	152,5	full=220

SHUTON-IPIRANGA advises to use the dimensions of the tables, although it is possible to manufacture ball screw with other dimensions. In brackets () second options.

Smaller nut diameters than the first option of the table can reduce the rigidity of the assembly between 5 and 10%. Please consult SHUTON-IPIRANGA.

High Load HDL TS Single nut, DN up to 110.000

Ball screw reference	Number of starts	Nominal diameter (mm)	Lead (mm)	Ball Diameter (mm)	Root diameter (mm)	Circuits	Dynamic load capacity	Static load capacity	Peak load CO-CO TR-TR 'TS'	Nut length
	$l/2$	d_0	P_h	D_w	d_2	i	C_a [kN]	C_{oa} [kN]	F_{max} [kN]	L_{nstd} [mm]
HDL TSB-B 70-20-15-7	1	70	20	15,875	57,1	7	498,1	1217,8	270	189
HDL TSB-B 70-20-15-8	1	70	20	15,875	57,1	8	563,1	1410	300	209
HDL TSB-B 70-20-15-9	1	70	20	15,875	57,1	9	623,7	1589,5	330	229
HDL TSB-B 70-20-15-10	1	70	20	15,875	57,1	10	663,4	1692	370	259
HDL TSB-B 70-20-15-11	1	70	20	15,875	57,1	11	729,2	1897,1	410	274
HDL TSB-B 70-25-12-2	1	70	25	12,7	60	2	121,8	238,7	50	93
HDL TSB-B 70-25-12-3	1	70	25	12,7	60	3	171,6	381,9	85	118
HDL TSB-B 70-25-12-4	1	70	25	12,7	60	4	221,4	525,1	110	143
HDL TSB-B 70-25-12-5	1	70	25	12,7	60	5	270,1	668,4	140	168
HDL TSB-B 70-25-12-6	1	70	25	12,7	60	6	319,7	819,5	170	193
HDL TSB-B 70-25-12-7	1	70	25	12,7	60	7	352	907,1	190	231
HDL TSB-B 70-25-12-8	1	70	25	12,7	60	8	397,9	1050,3	220	256
HDL TSB-B 70-25-12-9	1	70	25	12,7	60	9	443,1	1193,5	240	274
HDL TSB-B 70-25-15-2	1	70	25	15,875	57,1	2	162,5	294,2	70	99
HDL TSB-B 70-25-15-3	1	70	25	15,875	57,1	3	230	473,3	110	124
HDL TSB-B 70-25-15-4	1	70	25	15,875	57,1	4	301	665,2	150	149
HDL TSB-B 70-25-15-5	1	70	25	15,875	57,1	5	366,5	844,2	190	174
HDL TSB-B 70-25-15-6	1	70	25	15,875	57,1	6	434,1	1036,1	230	199
HDL TSB-B 70-25-15-7	1	70	25	15,875	57,1	7	500,2	1228	260	224
HDL TSB-B 70-25-15-8	1	70	25	15,875	57,1	8	561,6	1407,1	300	249
HDL TSB-B 70-30-12-2	1	70	30	12,7	60	2	121,3	238,1	50	103
HDL TSB-B 70-30-12-3	1	70	30	12,7	60	3	171,1	380,9	85	133
HDL TSB-B 70-30-12-4	1	70	30	12,7	60	4	220,6	523,8	110	163
HDL TSB-B 70-30-12-5	1	70	30	12,7	60	5	271,3	674,6	140	193
HDL TSB-B 70-30-12-6	1	70	30	12,7	60	6	318,6	817,4	170	223
HDL TSB-B 70-30-12-7	1	70	30	12,7	60	7	350,8	904,7	190	268
HDL TSB-B 70-30-15-2	1	70	30	15,875	57,1	2	162	293,5	70	109
HDL TSB-B 70-30-15-3	1	70	30	15,875	57,1	3	229,2	472,1	110	139
HDL TSB-B 70-30-15-4	1	70	30	15,875	57,1	4	300	663,5	150	169
HDL TSB-B 70-30-15-5	1	70	30	15,875	57,1	5	368,9	854,8	190	199
HDL TSB-B 70-30-15-6	1	70	30	15,875	57,1	6	432,6	1033,5	230	229
HDL TSB-B 70-30-15-7	1	70	30	15,875	57,1	7	498,5	1224,9	260	259
HDL TSB(2S)-B 70-32-12-2	2	70	32	12,7	60	2	188	396,4	85	109
HDL TSB(2S)-B 70-32-12-3	2	70	32	12,7	60	3	265	634,2	140	141
HDL TSB(2S)-B 70-32-12-4	2	70	32	12,7	60	4	341,8	872	190	173
HDL TSB(2S)-B 70-32-12-5	2	70	32	12,7	60	5	420,3	1123	230	205

- C_a and C_{oa} : Modified static and dynamic load capacities, calculated according to DIN 69051/4 standard and ISO3408/5. See Technical description catalogue.

- Check with SHUTON-IPIRANGA in case higher loads or more adjusted nut dimensions are required.

- Check external maximum axial force in the two senses.

For the indicated leads, in case C_a and C_{oa} requirements is lower, there is possibility of smaller size balls.

Maximum force (Peak load CO-CO and TR-TR) calculated with the flange/nut clamping in opposite position to the main support of the shaft, with same load type (traction or compression) in both nut and shaft. For same-side clamping, so different type of load, contact SHUTON-IPIRANGA as peak load is lower.

Nut dimensions									Grease quantity TS
$D_{1, std}$	$D_{1, min}$	D_4	D_6	D_5	L_7	L_1	L_8	L_9	$Q_{Gr} [cm^3]$
130		150	170	13,5	45	25	135	152,5	full=246
130		150	170	13,5	45	25	135	152,5	full=270
130		150	170	13,5	45	25	135	152,5	full=300
130		150	170	13,5	45	25	135	152,5	full=341
130		150	170	13,5	45	25	135	152,5	full=349
120		140	160	13,5	40	25	125	142,5	full=86
120		140	160	13,5	40	25	125	142,5	full=105
120		140	160	13,5	40	25	125	142,5	full=126
120		140	160	13,5	40	25	125	142,5	full=146
120		140	160	13,5	40	25	125	142,5	full=167
120		140	160	13,5	40	25	125	142,5	full=210
120		140	160	13,5	40	25	125	142,5	full=230
120		140	160	13,5	40	25	125	142,5	full=240
130		150	170	13,5	45	25	135	152,5	full=128
130		150	170	13,5	45	25	135	152,5	full=156
130		150	170	13,5	45	25	135	152,5	full=179
130		150	170	13,5	45	25	135	152,5	full=206
130		150	170	13,5	45	25	135	152,5	full=232
130		150	170	13,5	45	25	135	152,5	full=259
130		150	170	13,5	45	25	135	152,5	full=289
120		140	160	13,5	40	25	125	142,5	full=89
120		140	160	13,5	40	25	125	142,5	full=112
120		140	160	13,5	40	25	125	142,5	full=136
120		140	160	13,5	40	25	125	142,5	full=159
120		140	160	13,5	40	25	125	142,5	full=184
120		140	160	13,5	40	25	125	142,5	full=232
130		150	170	13,5	45	25	135	152,5	full=128
130		150	170	13,5	45	25	135	152,5	full=160
130		150	170	13,5	45	25	135	152,5	full=187
130		150	170	13,5	45	25	135	152,5	full=216
130		150	170	13,5	45	25	135	152,5	full=247
130		150	170	13,5	45	25	135	152,5	full=279
120		140	160	13,5	40	25	125	142,5	full=119
120		140	160	13,5	40	25	125	142,5	full=146
120		140	160	13,5	40	25	125	142,5	full=174
120		140	160	13,5	40	25	125	142,5	full=201

SHUTON-IPIRANGA advises to use the dimensions of the tables, although it is possible to manufacture ball screw with other dimensions. In brackets () second options.

Smaller nut diameters than the first option of the table can reduce the rigidity of the assembly between 5 and 10%. Please consult SHUTON-IPIRANGA.

High Load HDL TS Single nut, DN up to 110.000

Ball screw reference	Number of starts	Nominal diameter (mm)	Lead (mm)	Ball Diameter (mm)	Root diameter (mm)	Circuits	Dynamic load capacity	Static load capacity	Peak load CO-CO TR-TR 'TS'	Nut length
	$1/2$	d_0	P_h	D_w	d_2	i	C_a [kN]	C_{oa} [kN]	F_{max} [kN]	$L_{n, std}$ [mm]
HDL TSB(2S)-B 70-32-12-6	2	70	32	12,7	60	6	493,6	1360,8	280	237
HDL TSB(2S)-B 70-32-12-7	2	70	32	12,7	60	7	543,5	1506,1	310	276
HDL TSB(2S)-U 70-40-12-2	2	70	40	12,7	60	2	186,7	394,2	85	126
HDL TSB(2S)-U 70-40-12-3	2	70	40	12,7	60	3	266,9	643,9	140	166
HDL TSB(2S)-U 70-40-12-4	2	70	40	12,7	60	4	342,9	880,5	180	206
HDL TSB(2S)-U 70-40-12-5	2	70	40	12,7	60	5	417,4	1117	230	246
HDL TSB(2S)-B 70-40-15-2	2	70	40	15,875	57,1	2	249,3	485,9	120	131
HDL TSB(2S)-B 70-40-15-3	2	70	40	15,875	57,1	3	359	802,9	180	171
HDL TSB(2S)-B 70-40-15-4	2	70	40	15,875	57,1	4	461,6	1098,7	250	211
HDL TSB(2S)-B 70-40-15-5	2	70	40	15,875	57,1	5	567,7	1415,6	310	251
HDL TSB(2S)-U 70-50-12-2	2	70	50	12,7	60	2	184,7	391	85	136
HDL TSB(2S)-U 70-50-12-3	2	70	50	12,7	60	3	264	638,6	140	186
HDL TSB(2S)-U 70-50-12-4	2	70	50	12,7	60	4	339,3	873,3	180	236
HDL TSB(2S)-U 70-50-15-2	2	70	50	15,875	57,1	2	246,6	482	110	145
HDL TSB(2S)-U 70-50-15-3	2	70	50	15,875	57,1	3	355,2	796,3	180	195
HDL TSB(2S)-U 70-50-15-4	2	70	50	15,875	57,1	4	462,5	1110,7	240	245
HDL TSB-B 80-16-12-2	1	80	16	12,7	70	2	132,6	281,9	65	75
HDL TSB-B 80-16-12-3	1	80	16	12,7	70	3	184,7	442,9	95	91
HDL TSB-B 80-16-12-4	1	80	16	12,7	70	4	239	612	130	107
HDL TSB-B 80-16-12-5	1	80	16	12,7	70	5	290	773,1	170	123
HDL TSB-B 80-16-12-6	1	80	16	12,7	70	6	342	942,2	200	139
HDL TSB-B 80-16-12-7	1	80	16	12,7	70	7	381,3	1063	230	163
HDL TSB-B 80-16-12-8	1	80	16	12,7	70	8	429,5	1224	260	179
HDL TSB-B 80-16-12-9	1	80	16	12,7	70	9	477	1385,1	290	195
HDL TSB-B 80-16-12-10	1	80	16	12,7	70	10	523,7	1546,2	320	211
HDL TSB-B 80-16-12-11	1	80	16	12,7	70	11	573,3	1723,3	350	227
HDL TSB-B 80-16-12-12	1	80	16	12,7	70	12	618,7	1884,4	380	243
HDL TSB-B 80-16-12-13	1	80	16	12,7	70	13	654,8	2005,2	410	262
HDL TSB-B 80-16-12-14	1	80	16	12,7	70	14	701,1	2174,3	440	278
HDL TSB-B 80-16-12-15	1	80	16	12,7	70	15	741,7	2319,2	470	294
HDL TSB-B 80-16-12-16	1	80	16	12,7	70	16	787	2488,4	490	310
HDL TSB-B 80-16-12-17	1	80	16	12,7	70	17	831,9	2657,5	510	326
HDL TSB-B 80-16-12-18	1	80	16	12,7	70	18	876,5	2826,6	540	342
HDL TSB-B 80-16-12-19	1	80	16	12,7	70	19	907,4	2931,3	560	357
HDL TSB-B 80-20-12-2	1	80	20	12,7	70	2	132,4	281,6	60	98
HDL TSB-U 80-20-12-3	1	80	20	12,7	70	3	184,4	442,4	95	118

- C_a and C_{oa} : Modified static and dynamic load capacities, calculated according to DIN 69051/4 standard and ISO3408/5. See Technical description catalogue.

- Check with SHUTON-IPIRANGA in case higher loads or more adjusted nut dimensions are required.

- Check external maximum axial force in the two senses.

For the indicated leads, in case C_a and C_{oa} requirements is lower, there is possibility of smaller size balls.

Maximum force (Peak load CO-CO and TR-TR) calculated with the flange/nut clamping in opposite position to the main support of the shaft, with same load type (traction or compression) in both nut and shaft. For same-side clamping, so different type of load, contact SHUTON-IPIRANGA as peak load is lower.

Nut dimensions									Grease quantity TS
$D_{1, std}$	$D_{1, min}$	D_4	D_6	D_5	L_7	L_1	L_8	L_9	$Q_{Gr} [cm^3]$
120		140	160	13,5	40	25	125	142,5	full=232
120		140	160	13,5	40	25	125	142,5	full=281
120		140	160	13,5	25	25	125	142,5	full=84
120		140	160	13,5	25	25	125	142,5	full=114
120		140	160	13,5	25	25	125	142,5	full=149
120		140	160	13,5	25	25	125	142,5	full=183
130		150	170	13,5	45	25	135	152,5	full=185
130		150	170	13,5	45	25	135	152,5	full=229
130		150	170	13,5	45	25	135	152,5	full=273
130		150	170	13,5	45	25	135	152,5	full=317
120		140	160	13,5	25	25	125	142,5	full=92
120		140	160	13,5	25	25	125	142,5	full=129
120		140	160	13,5	25	25	125	142,5	full=171
130		150	170	13,5	30	25	135	152,5	full=124
130		150	170	13,5	30	25	135	152,5	full=176
130		150	170	13,5	30	25	135	152,5	full=224
130		150	170	13,5	40	25	135	152,5	full=96
130		150	170	13,5	40	25	135	152,5	full=112
130		150	170	13,5	40	25	135	152,5	full=128
130		150	170	13,5	40	25	135	152,5	full=144
130		150	170	13,5	40	25	135	152,5	full=160
130		150	170	13,5	40	25	135	152,5	full=195
130		150	170	13,5	40	25	135	152,5	full=213
130		150	170	13,5	40	25	135	152,5	full=230
130		150	170	13,5	40	25	135	152,5	full=246
130		150	170	13,5	40	25	135	152,5	full=262
130		150	170	13,5	40	25	135	152,5	full=279
130		150	170	13,5	40	25	135	152,5	full=301
130		150	170	13,5	40	25	135	152,5	full=317
130		150	170	13,5	40	25	135	152,5	full=337
130		150	170	13,5	40	25	135	152,5	full=353
130		150	170	13,5	40	25	135	152,5	full=370
130		153	176	15,5	40	25	135	155,5	full=386
130		153	176	15,5	40	25	135	155,5	full=400
135	(130)	155 (150)	175 (170)	13,5	25	25	140 (135)	157,5 (152,5)	full=92
135	(130)	155 (150)	175 (170)	13,5	25	25	140 (135)	157,5 (152,5)	full=112

SHUTON-IPIRANGA advises to use the dimensions of the tables, although it is possible to manufacture ball screw with other dimensions. In brackets () second options.

Smaller nut diameters than the first option of the table can reduce the rigidity of the assembly between 5 and 10%. Please consult SHUTON-IPIRANGA.

High Load HDL TS Single nut, DN up to 110.000

Ball screw reference	Number of starts	Nominal diameter (mm)	Lead (mm)	Ball Diameter (mm)	Root diameter (mm)	Circuits	Dynamic load capacity	Static load capacity	Peak load CO-CO TR-TR 'TS'	Nut length
	$l/2$	d_0	P_h	D_w	d_2	i	C_{da} [kN]	C_{oa} [kN]	F_{max} [kN]	L_{nstd} [mm]
HDL TSB-U 80-20-12-4	1	80	20	12,7	70	4	238,6	611,4	130	138
HDL TSB-U 80-20-12-5	1	80	20	12,7	70	5	289,6	772,3	160	158
HDL TSB-U 80-20-12-6	1	80	20	12,7	70	6	341,5	941,2	200	178
HDL TSB-U 80-20-12-7	1	80	20	12,7	70	7	392,2	1110,1	230	198
HDL TSB-U 80-20-12-8	1	80	20	12,7	70	8	440,2	1271	250	218
HDL TSB-B 80-20-12-9	1	80	20	12,7	70	9	476,3	1383,6	290	233
HDL TSB-B 80-20-12-10	1	80	20	12,7	70	10	522,9	1544,5	320	253
HDL TSB-B 80-20-12-11	1	80	20	12,7	70	11	572,5	1721,5	340	273
HDL TSB-B 80-20-12-12	1	80	20	12,7	70	12	617,8	1882,4	370	293
HDL TSB-B 80-20-12-13	1	80	20	12,7	70	13	653,9	2003,1	400	317
HDL TSB-B 80-20-12-14	1	80	20	12,7	70	14	700,1	2172	430	337
HDL TSB-B 80-20-12-15	1	80	20	12,7	70	15	740,6	2316,8	450	355
HDL TSB-B 80-20-12-16	1	80	20	12,7	70	16	785,9	2485,7	460	368
HDL TSB-B 80-20-15-2	1	80	20	15,875	67,1	2	178,7	349,9	80	89
HDL TSB-B 80-20-15-3	1	80	20	15,875	67,1	3	251,2	557,3	130	109
HDL TSB-B 80-20-15-4	1	80	20	15,875	67,1	4	327,2	777,6	180	129
HDL TSB-B 80-20-15-5	1	80	20	15,875	67,1	5	397,9	984,9	230	149
HDL TSB-B 80-20-15-6	1	80	20	15,875	67,1	6	470,3	1205,2	270	169
HDL TSB-B 80-20-15-7	1	80	20	15,875	67,1	7	538	1412,6	310	189
HDL TSB-B 80-20-15-8	1	80	20	15,875	67,1	8	588,1	1555,1	350	219
HDL TSB-B 80-20-15-9	1	80	20	15,875	67,1	9	653,7	1762,5	400	239
HDL TSB-B 80-20-15-10	1	80	20	15,875	67,1	10	718,3	1969,9	440	259
HDL TSB-B 80-20-15-11	1	80	20	15,875	67,1	11	782	2177,2	470	279
HDL TSB-B 80-20-15-12	1	80	20	15,875	67,1	12	850,9	2410,5	510	299
HDL TSB-B 80-20-15-13	1	80	20	15,875	67,1	13	913	2617,8	540	319
HDL TSB-B 80-20-15-14	1	80	20	15,875	67,1	14	974,3	2825,2	580	339
HDL TSB-B 80-20-15-15	1	80	20	15,875	67,1	15	1017,3	2954,8	610	361
HDL TSB-B 80-25-15-2	1	80	25	15,875	67,1	2	178,4	349,3	80	99
HDL TSB-B 80-25-15-3	1	80	25	15,875	67,1	3	250,7	556,4	130	124
HDL TSB-B 80-25-15-4	1	80	25	15,875	67,1	4	326,5	776,3	180	149
HDL TSB-B 80-25-15-5	1	80	25	15,875	67,1	5	397	983,3	230	174
HDL TSB-B 80-25-15-6	1	80	25	15,875	67,1	6	469,3	1203,3	270	199
HDL TSB-B 80-25-15-7	1	80	25	15,875	67,1	7	536,8	1410,3	310	224
HDL TSB-B 80-25-15-8	1	80	25	15,875	67,1	8	586,9	1552,6	350	262
HDL TSB-B 80-25-15-9	1	80	25	15,875	67,1	9	652,3	1759,6	390	287
HDL TSB-B 80-25-15-10	1	80	25	15,875	67,1	10	716,8	1966,6	420	312

- C_a and C_{oa} : Modified static and dynamic load capacities, calculated according to DIN 69051/4 standard and ISO3408/5. See Technical description catalogue.

- Check with SHUTON-IPIRANGA in case higher loads or more adjusted nut dimensions are required.

- Check external maximum axial force in the two senses.

For the indicated leads, in case C_a and C_{oa} requirements is lower, there is possibility of smaller size balls.

Maximum force (Peak load CO-CO and TR-TR) calculated with the flange/nut clamping in opposite position to the main support of the shaft, with same load type (traction or compression) in both nut and shaft. For same-side clamping, so different type of load, contact SHUTON-IPIRANGA as peak load is lower.

Nut dimensions									Grease quantity TS
$D_{1, std}$	$D_{1, min}$	D_4	D_6	D_5	L_7	L_1	L_8	L_9	$Q_{Gr} [cm^3]$
135	(130)	155 (150)	175 (170)	13,5	25	25	140 (135)	157,5 (152,5)	full=130
135	(130)	155 (150)	175 (170)	13,5	25	25	140 (135)	157,5 (152,5)	full=150
135	(130)	155 (150)	175 (170)	13,5	25	25	140 (135)	157,5 (152,5)	full=170
135	(130)	155 (150)	175 (170)	13,5	25	25	140 (135)	157,5 (152,5)	full=190
135	(130)	155 (150)	175 (170)	13,5	25	25	140 (135)	157,5 (152,5)	full=213
130		150	170	13,5	40	25	135	152,5	full=252
130		150	170	13,5	40	25	135	152,5	full=271
130		150	170	13,5	40	25	135	152,5	full=291
130		150	170	13,5	40	25	135	152,5	full=310
130		150	170	13,5	40	25	135	152,5	full=337
130		150	170	13,5	40	25	135	152,5	full=356
130		150	170	13,5	40	25	135	152,5	full=375
130		150	170	13,5	40	25	135	152,5	full=381
140		166	192	17,5	45	25	145	168,5	full=150
140		166	192	17,5	45	25	145	168,5	full=174
140		166	192	17,5	45	25	145	168,5	full=196
140		166	192	17,5	45	25	145	168,5	full=222
140		166	192	17,5	45	25	145	168,5	full=248
140		166	192	17,5	45	25	145	168,5	full=276
140		166	192	17,5	45	25	145	168,5	full=328
140		166	192	17,5	45	25	145	168,5	full=354
140		166	192	17,5	45	25	145	168,5	full=380
140		166	192	17,5	45	25	145	168,5	full=410
140		166	192	17,5	45	25	145	168,5	full=432
140		166	192	17,5	45	25	145	168,5	full=463
140		166	192	17,5	45	25	145	168,5	full=489
140		166	192	17,5	45	25	145	168,5	full=516
140		166	192	17,5	45	25	145	168,5	full=146
140		166	192	17,5	45	25	145	168,5	full=174
140		166	192	17,5	45	25	145	168,5	full=200
140		166	192	17,5	45	25	145	168,5	full=231
140		166	192	17,5	45	25	145	168,5	full=261
140		166	192	17,5	45	25	145	168,5	full=294
140		166	192	17,5	45	25	145	168,5	full=353
140		166	192	17,5	45	25	145	168,5	full=383
140		166	192	17,5	45	25	145	168,5	full=414

SHUTON-IPIRANGA advises to use the dimensions of the tables, although it is possible to manufacture ball screw with other dimensions. In brackets () second options.

Smaller nut diameters than the first option of the table can reduce the rigidity of the assembly between 5 and 10%. Please consult SHUTON-IPIRANGA.

High Load HDL TS Single nut, DN up to 110.000

Ball screw reference	Number of starts	Nominal diameter (mm)	Lead (mm)	Ball Diameter (mm)	Root diameter (mm)	Circuits	Dynamic load capacity	Static load capacity	Peak load CO-CO TR-TR 'TS'	Nut length
	$l/2$	d_0	P_h	D_w	d_2	i	C_a [kN]	C_{oa} [kN]	F_{max} [kN]	$L_{n,std}$ [mm]
HDL TSB-B 80-25-15-11	1	80	25	15,875	67,1	11	786,5	2199,5	460	337
HDL TSB-B 80-25-15-12	1	80	25	15,875	67,1	12	849,1	2406,6	490	360
HDL TSB-B 80-25-19-2	1	80	25	19,05	64,1	2	219,3	398,4	100	105
HDL TSB-B 80-25-19-3	1	80	25	19,05	64,1	3	317,7	663,9	160	130
HDL TSB-B 80-25-19-4	1	80	25	19,05	64,1	4	414,7	929,5	220	155
HDL TSB-B 80-25-19-5	1	80	25	19,05	64,1	5	509,3	1195,1	280	180
HDL TSB-B 80-25-19-6	1	80	25	19,05	64,1	6	601,6	1460,6	340	205
HDL TSB-B 80-25-19-7	1	80	25	19,05	64,1	7	686,8	1707,2	390	230
HDL TSB-B 80-25-19-8	1	80	25	19,05	64,1	8	775,5	1972,8	430	255
HDL TSB-B 80-25-19-9	1	80	25	19,05	64,1	9	833,1	2124,5	470	293
HDL TSB-B 80-25-19-10	1	80	25	19,05	64,1	10	919,4	2390,1	540	318
HDL TSB-B 80-25-19-11	1	80	25	19,05	64,1	11	1004,5	2655,7	580	343
HDL TSB-B 80-25-19-12	1	80	25	19,05	64,1	12	1088,4	2921,2	610	366
HDL TSB-B 80-30-15-2	1	80	30	15,875	67,1	2	177,9	348,6	80	109
HDL TSB-B 80-30-15-3	1	80	30	15,875	67,1	3	250	555,2	130	139
HDL TSB-B 80-30-15-4	1	80	30	15,875	67,1	4	325,7	774,8	180	169
HDL TSB-B 80-30-15-5	1	80	30	15,875	67,1	5	396	981,4	220	199
HDL TSB-B 80-30-15-6	1	80	30	15,875	67,1	6	468,1	1200,9	260	229
HDL TSB-B 80-30-15-7	1	80	30	15,875	67,1	7	538,7	1420,4	300	259
HDL TSB-B 80-30-15-8	1	80	30	15,875	67,1	8	585,4	1549,5	340	304
HDL TSB-B 80-30-15-9	1	80	30	15,875	67,1	9	650,6	1756,1	370	334
HDL TSB-B 80-30-15-10	1	80	30	15,875	67,1	10	714,9	1962,7	410	362
HDL TSB-B 80-30-19-2	1	80	30	19,05	64,1	2	218,7	397,6	100	115
HDL TSB-B 80-30-19-3	1	80	30	19,05	64,1	3	316,9	662,6	160	145
HDL TSB-B 80-30-19-4	1	80	30	19,05	64,1	4	413,6	927,7	220	175
HDL TSB-B 80-30-19-5	1	80	30	19,05	64,1	5	508	1192,7	280	205
HDL TSB-B 80-30-19-6	1	80	30	19,05	64,1	6	600	1457,7	330	235
HDL TSB-B 80-30-19-7	1	80	30	19,05	64,1	7	690,1	1722,8	380	265
HDL TSB-B 80-30-19-8	1	80	30	19,05	64,1	8	743,5	1855,3	410	310
HDL TSB-B 80-30-19-9	1	80	30	19,05	64,1	9	831	2120,3	460	340
HDL TSB-B 80-30-19-10	1	80	30	19,05	64,1	10	917,1	2385,4	510	361
HDL TSB(2S)-U 80-32-12-2	2	80	32	12,7	70	2	204,2	467,1	100	116
HDL TSB(2S)-U 80-32-12-3	2	80	32	12,7	70	3	287,9	747,4	160	148
HDL TSB(2S)-U 80-32-12-4	2	80	32	12,7	70	4	368,1	1014,3	210	180
HDL TSB(2S)-U 80-32-12-5	2	80	32	12,7	70	5	449,9	1294,6	270	212
HDL TSB(2S)-U 80-32-12-6	2	80	32	12,7	70	6	529,8	1574,9	320	244

- C_a and C_{oa} : Modified static and dynamic load capacities, calculated according to DIN 69051/4 standard and ISO3408/5. See Technical description catalogue.

- Check with SHUTON-IPIRANGA in case higher loads or more adjusted nut dimensions are required.

- Check external maximum axial force in the two senses.

For the indicated leads, in case C_a and C_{oa} requirements is lower, there is possibility of smaller size balls.

Maximum force (Peak load CO-CO and TR-TR) calculated with the flange/nut clamping in opposite position to the main support of the shaft, with same load type (traction or compression) in both nut and shaft. For same-side clamping, so different type of load, contact SHUTON-IPIRANGA as peak load is lower.

Nut dimensions									Grease quantity TS
$D_{1, std}$	$D_{1, min}$	D_4	D_6	D_5	L_7	L_1	L_8	L_9	$Q_G [cm^3]$
140		166	192	17,5	45	25	145	168,5	full=444
140		166	192	17,5	45	25	145	168,5	full=470
150		176	202	17,5	50	40	155	178,5	full=214
150		176	202	17,5	50	40	155	178,5	full=247
150		176	202	17,5	50	40	155	178,5	full=285
150		176	202	17,5	50	40	155	178,5	full=318
150		176	202	17,5	50	40	155	178,5	full=359
150		176	202	17,5	50	40	155	178,5	full=400
150		176	202	17,5	50	40	155	178,5	full=444
150		176	202	17,5	50	40	155	178,5	full=523
150		176	202	17,5	50	40	155	178,5	full=553
150		176	202	17,5	50	40	155	178,5	full=590
150		176	202	17,5	50	40	155	178,5	full=628
140		166	192	17,5	45	25	145	168,5	full=146
140		166	192	17,5	45	25	145	168,5	full=179
140		166	192	17,5	45	25	145	168,5	full=209
140		166	192	17,5	45	25	145	168,5	full=244
140		166	192	17,5	45	25	145	168,5	full=279
140		166	192	17,5	45	25	145	168,5	full=313
140		166	192	17,5	45	25	145	168,5	full=380
140		166	192	17,5	45	25	145	168,5	full=415
140		166	192	17,5	45	25	145	168,5	full=445
150		176	202	17,5	50	40	155	178,5	full=209
150		176	202	17,5	50	40	155	178,5	full=247
150		176	202	17,5	50	40	155	178,5	full=289
150		176	202	17,5	50	40	155	178,5	full=327
150		176	202	17,5	50	40	155	178,5	full=372
150		176	202	17,5	50	40	155	178,5	full=414
150		176	202	17,5	50	40	155	178,5	full=509
150		176	202	17,5	50	40	155	178,5	full=551
150		176	202	17,5	50	40	155	178,5	full=560
135	(130)	155 (150)	175 (170)	13,5	25	25	140 (135)	157,5 (152,5)	full=121
135	(130)	155 (150)	175 (170)	13,5	25	25	140 (135)	157,5 (152,5)	full=152
135	(130)	155 (150)	175 (170)	13,5	25	25	140 (135)	157,5 (152,5)	full=185
135	(130)	155 (150)	175 (170)	13,5	25	25	140 (135)	157,5 (152,5)	full=216
135	(130)	155 (150)	175 (170)	13,5	25	25	140 (135)	157,5 (152,5)	full=249

SHUTON-IPIRANGA advises to use the dimensions of the tables, although it is possible to manufacture ball screw with other dimensions. In brackets () second options.

Smaller nut diameters than the first option of the table can reduce the rigidity of the assembly between 5 and 10%. Please consult SHUTON-IPIRANGA.

High Load HDL TS Single nut, DN up to 110.000

Ball screw reference	Number of starts	Nominal diameter (mm)	Lead (mm)	Ball Diameter (mm)	Root diameter (mm)	Circuits	Dynamic load capacity	Static load capacity	Peak load CO-CO TR-TR 'TS'	Nut length
	$1/2$	d_0	P_h	D_w	d_2	i	C_a [kN]	C_{oa} [kN]	F_{max} [kN]	L_{nstd} [mm]
HDL TSB(2S)-U 80-32-12-7	2	80	32	12,7	70	7	605	1841,8	360	276
HDL TSB(2S)-B 80-32-12-8	2	80	32	12,7	70	8	661,7	2028,7	410	317
HDL TSB(2S)-B 80-32-12-9	2	80	32	12,7	70	9	740,4	2322,3	450	349
HDL TSB(2S)-B 80-32-12-10	2	80	32	12,7	70	10	812,2	2589,3	490	369
HDL TSB(2S)-U 80-40-12-2	2	80	40	12,7	70	2	203,1	465,2	100	126
HDL TSB(2S)-U 80-40-12-3	2	80	40	12,7	70	3	286,4	744,3	160	166
HDL TSB(2S)-U 80-40-12-4	2	80	40	12,7	70	4	369,3	1023,4	210	206
HDL TSB(2S)-U 80-40-12-5	2	80	40	12,7	70	5	447,5	1289,3	260	246
HDL TSB(2S)-U 80-40-12-6	2	80	40	12,7	70	6	526,9	1568,4	310	286
HDL TSB(2S)-B 80-40-12-7	2	80	40	12,7	70	7	584,2	1754,5	350	343
HDL TSB(2S)-B 80-40-12-8	2	80	40	12,7	70	8	663,9	2046,9	390	368
HDL TSB(2S)-B 80-40-15-2	2	80	40	15,875	67,1	2	274,2	578,2	130	131
HDL TSB(2S)-B 80-40-15-3	2	80	40	15,875	67,1	3	391,4	942,2	220	171
HDL TSB(2S)-B 80-40-15-4	2	80	40	15,875	67,1	4	502	1284,8	290	211
HDL TSB(2S)-B 80-40-15-5	2	80	40	15,875	67,1	5	615,8	1648,8	360	251
HDL TSB(2S)-B 80-40-15-6	2	80	40	15,875	67,1	6	695,5	1884,4	410	311
HDL TSB(2S)-B 80-40-15-7	2	80	40	15,875	67,1	7	800	2227	470	351
HDL TSB(2S)-U 80-50-15-2	2	80	50	15,875	67,1	2	272	574,5	130	147
HDL TSB(2S)-U 80-50-15-3	2	80	50	15,875	67,1	3	388,1	936,2	210	197
HDL TSB(2S)-U 80-50-15-4	2	80	50	15,875	67,1	4	503,4	1297,9	290	247
HDL TSB(2S)-U 80-50-15-5	2	80	50	15,875	67,1	5	610,7	1638,3	350	297
HDL TSB(2S)-B 80-50-15-6	2	80	50	15,875	67,1	6	689,8	1872,4	390	358
HDL TSB(2S)-B 80-50-19-2	2	80	50	19,05	64,1	2	344,9	686,3	170	157
HDL TSB(2S)-B 80-50-19-3	2	80	50	19,05	64,1	3	493,6	1123,1	270	207
HDL TSB(2S)-B 80-50-19-4	2	80	50	19,05	64,1	4	641	1559,8	360	257
HDL TSB(2S)-B 80-50-19-5	2	80	50	19,05	64,1	5	735	1809,4	400	332
HDL TSB(2S)-B 80-50-19-6	2	80	50	19,05	64,1	6	877,3	2246,2	490	368
HDL TSB-U 100-16-12-2	1	100	16	12,7	90	2	149,9	366,7	80	78
HDL TSB-U 100-16-12-3	1	100	16	12,7	90	3	207,4	570,4	120	94
HDL TSB-U 100-16-12-4	1	100	16	12,7	90	4	267	782,2	170	110
HDL TSB-U 100-16-12-5	1	100	16	12,7	90	5	323,7	985,9	210	126
HDL TSB-U 100-16-12-6	1	100	16	12,7	90	6	380,8	1197,8	250	142
HDL TSB-U 100-16-12-7	1	100	16	12,7	90	7	435	1401,5	290	158
HDL TSB-U 100-16-12-8	1	100	16	12,7	90	8	490	1613,4	320	174
HDL TSB-B 100-16-12-9	1	100	16	12,7	90	9	521	1711,1	370	198
HDL TSB-B 100-16-12-10	1	100	16	12,7	90	10	576,2	1931,1	410	214

- C_a and C_{oa} : Modified static and dynamic load capacities, calculated according to DIN 69051/4 standard and ISO3408/5. See Technical description catalogue.

- Check with SHUTON-IPIRANGA in case higher loads or more adjusted nut dimensions are required.

- Check external maximum axial force in the two senses.

For the indicated leads, in case C_a and C_{oa} requirements is lower, there is possibility of smaller size balls.

Maximum force (Peak load CO-CO and TR-TR) calculated with the flange/nut clamping in opposite position to the main support of the shaft, with same load type (traction or compression) in both nut and shaft. For same-side clamping, so different type of load, contact SHUTON-IPIRANGA as peak load is lower.

Nut dimensions									Grease quantity TS
$D_{1, std}$	$D_{1, min}$	D_4	D_6	D_5	L_7	L_1	L_8	L_9	$Q_{Gr} [cm^3]$
135	(130)	155 (150)	175 (170)	13,5	25	25	140 (135)	157,5 (152,5)	full=287
130		150	170	13,5	40	25	135	152,5	full=369
130		150	170	13,5	40	25	135	152,5	full=398
130		150	170	13,5	40	25	135	152,5	full=404
135	(130)	155 (150)	175 (170)	13,5	25	25	140 (135)	157,5 (152,5)	full=124
135	(130)	155 (150)	175 (170)	13,5	25	25	140 (135)	157,5 (152,5)	full=161
135	(130)	155 (150)	175 (170)	13,5	25	25	140 (135)	157,5 (152,5)	full=199
135	(130)	155 (150)	175 (170)	13,5	25	25	140 (135)	157,5 (152,5)	full=238
135	(130)	155 (150)	175 (170)	13,5	25	25	140 (135)	157,5 (152,5)	full=278
130		150	170	13,5	40	25	135	152,5	full=372
130		150	170	13,5	40	25	135	152,5	full=383
140		166	192	17,5	45	25	145	168,5	full=210
140		166	192	17,5	45	25	145	168,5	full=255
140		166	192	17,5	45	25	145	168,5	full=303
140		166	192	17,5	45	25	145	168,5	full=352
140		166	192	17,5	45	25	145	168,5	full=473
140		166	192	17,5	45	25	145	168,5	full=526
140		160	180	13,5	25	25	145	162,5	full=143
140		160	180	13,5	25	25	145	162,5	full=197
140		160	180	13,5	25	25	145	162,5	full=250
140		160	180	13,5	25	25	145	162,5	full=312
140		166	192	17,5	45	25	145	168,5	full=481
150		176	202	17,5	50	40	155	178,5	full=300
150		176	202	17,5	50	40	155	178,5	full=368
150		176	202	17,5	50	40	155	178,5	full=444
150		176	202	17,5	50	40	155	178,5	full=630
150		176	202	17,5	50	40	155	178,5	full=646
150		176	202	17,5	30	25	155	178,5	full=82
150		176	202	17,5	30	25	155	178,5	full=100
150		176	202	17,5	30	25	155	178,5	full=120
150		176	202	17,5	30	25	155	178,5	full=141
150		176	202	17,5	30	25	155	178,5	full=161
150		176	202	17,5	30	25	155	178,5	full=184
150		176	202	17,5	30	25	155	178,5	full=207
155	(150)	181 (176)	207 (202)	17,5	40	25	160 (155)	183,5 (178,5)	full=291
155	(150)	181 (176)	207 (202)	17,5	40	25	160 (155)	183,5 (178,5)	full=310

SHUTON-IPIRANGA advises to use the dimensions of the tables, although it is possible to manufacture ball screw with other dimensions. In brackets () second options.

Smaller nut diameters than the first option of the table can reduce the rigidity of the assembly between 5 and 10%. Please consult SHUTON-IPIRANGA.

High Load HDL TS Single nut, DN up to 110.000

Ball screw reference	Number of starts	Nominal diameter (mm)	Lead (mm)	Ball Diameter (mm)	Root diameter (mm)	Circuits	Dynamic load capacity	Static load capacity	Peak load CO-CO TR-TR 'TS'	Nut length
	$l/2$	d_0	P_h	D_w	d_2	i	C_{da} [kN]	C_{oa} [kN]	F_{max} [kN]	L_{nstd} [mm]
HDL TSB-B 100-16-12-11	1	100	16	12,7	90	11	625,8	2126,7	450	230
HDL TSB-B 100-16-12-12	1	100	16	12,7	90	12	679,5	2346,7	490	246
HDL TSB-B 100-16-12-13	1	100	16	12,7	90	13	715,3	2477,1	510	263
HDL TSB-B 100-16-12-14	1	100	16	12,7	90	14	769,5	2705,2	550	279
HDL TSB-B 100-16-12-15	1	100	16	12,7	90	15	816,9	2900,8	590	295
HDL TSB-B 100-16-12-16	1	100	16	12,7	90	16	869,9	3128,9	630	311
HDL TSB-B 100-16-12-17	1	100	16	12,7	90	17	904,5	3259,3	650	328
HDL TSB-B 100-16-12-18	1	100	16	12,7	90	18	952,2	3463	680	344
HDL TSB-B 100-16-12-19	1	100	16	12,7	90	19	999,5	3666,7	710	358
HDL TSB-B 100-16-12-20	1	100	16	12,7	90	20	1053,9	3911,2	750	374
HDL TSB-U 100-20-12-2	1	100	20	12,7	90	2	149,8	366,4	80	99
HDL TSB-U 100-20-12-3	1	100	20	12,7	90	3	207,2	570	120	119
HDL TSB-U 100-20-12-4	1	100	20	12,7	90	4	266,8	781,7	170	139
HDL TSB-U 100-20-12-5	1	100	20	12,7	90	5	323,4	985,3	210	159
HDL TSB-U 100-20-12-6	1	100	20	12,7	90	6	380,4	1197	250	180
HDL TSB-U 100-20-12-7	1	100	20	12,7	90	7	434,6	1400,5	280	199
HDL TSB-U 100-20-12-8	1	100	20	12,7	90	8	489,5	1612,2	320	219
HDL TSB-B 100-20-12-9	1	100	20	12,7	90	9	520,6	1710	370	237
HDL TSB-B 100-20-12-10	1	100	20	12,7	90	10	575,7	1929,8	400	257
HDL TSB-B 100-20-12-11	1	100	20	12,7	90	11	625,3	2125,2	440	277
HDL TSB-B 100-20-12-12	1	100	20	12,7	90	12	678,9	2345,1	470	297
HDL TSB-B 100-20-12-13	1	100	20	12,7	90	13	714,7	2475,4	500	318
HDL TSB-B 100-20-12-14	1	100	20	12,7	90	14	768,8	2703,4	530	338
HDL TSB-B 100-20-12-15	1	100	20	12,7	90	15	816,2	2898,8	560	356
HDL TSB-B 100-20-12-16	1	100	20	12,7	90	16	869,2	3126,8	600	376
HDL TSB-B 100-20-12-17	1	100	20	12,7	90	17	903,6	3257,1	620	397
HDL TSB-B 100-20-12-18	1	100	20	12,7	90	18	951,3	3460,6	640	417
HDL TSB-B 100-20-12-19	1	100	20	12,7	90	19	1006	3704,9	670	437
HDL TSB-B 100-20-12-20	1	100	20	12,7	90	20	1052,9	3908,5	690	457
HDL TSB-U 100-20-15-2	1	100	20	15,875	87,1	2	201,3	447,3	100	88
HDL TSB-U 100-20-15-3	1	100	20	15,875	87,1	3	285,8	723,6	170	108
HDL TSB-U 100-20-15-4	1	100	20	15,875	87,1	4	366,6	986,7	230	128
HDL TSB-U 100-20-15-5	1	100	20	15,875	87,1	5	448,9	1262,9	290	148
HDL TSB-U 100-20-15-6	1	100	20	15,875	87,1	6	526,2	1526	340	168
HDL TSB-U 100-20-15-7	1	100	20	15,875	87,1	7	604,9	1802,3	390	188
HDL TSB-U 100-20-15-8	1	100	20	15,875	87,1	8	679,3	2065,4	440	208

- C_a and C_{oa} : Modified static and dynamic load capacities, calculated according to DIN 69051/4 standard and ISO3408/5. See Technical description catalogue.

- Check with SHUTON-IPIRANGA in case higher loads or more adjusted nut dimensions are required.

- Check external maximum axial force in the two senses.

For the indicated leads, in case C_a and C_{oa} requirements is lower, there is possibility of smaller size balls.

Maximum force (Peak load CO-CO and TR-TR) calculated with the flange/nut clamping in opposite position to the main support of the shaft, with same load type (traction or compression) in both nut and shaft. For same-side clamping, so different type of load, contact SHUTON-IPIRANGA as peak load is lower.

Nut dimensions									Grease quantity TS
$D_{1, std}$	$D_{1, min}$	D_4	D_6	D_5	L_7	L_1	L_8	L_9	$Q_{Gr} [cm^3]$
155	(150)	181 (176)	207 (202)	17,5	40	25	160 (155)	183,5 (178,5)	full=331
155	(150)	181 (176)	207 (202)	17,5	40	25	160 (155)	183,5 (178,5)	full=350
155	(150)	181 (176)	207 (202)	17,5	40	25	160 (155)	183,5 (178,5)	full=379
155	(150)	181 (176)	207 (202)	17,5	40	25	160 (155)	183,5 (178,5)	full=397
155	(150)	181 (176)	207 (202)	17,5	40	25	160 (155)	183,5 (178,5)	full=416
155	(150)	181 (176)	207 (202)	17,5	40	25	160 (155)	183,5 (178,5)	full=434
155	(150)	181 (176)	207 (202)	17,5	40	25	160 (155)	183,5 (178,5)	full=461
155	(150)	181 (176)	207 (202)	17,5	40	25	160 (155)	183,5 (178,5)	full=484
155	(150)	181 (176)	207 (202)	17,5	40	25	160 (155)	183,5 (178,5)	full=496
155	(150)	181 (176)	207 (202)	17,5	40	25	160 (155)	183,5 (178,5)	full=513
150		176	202	17,5	30	25	155	178,5	full=116
150		176	202	17,5	30	25	155	178,5	full=138
150		176	202	17,5	30	25	155	178,5	full=162
150		176	202	17,5	30	25	155	178,5	full=187
150		176	202	17,5	30	25	155	178,5	full=214
150		176	202	17,5	30	25	155	178,5	full=238
150		176	202	17,5	30	25	155	178,5	full=265
155	(150)	181 (176)	207 (202)	17,5	40	25	160 (155)	183,5 (178,5)	full=320
155	(150)	181 (176)	207 (202)	17,5	40	25	160 (155)	183,5 (178,5)	full=342
155	(150)	181 (176)	207 (202)	17,5	40	25	160 (155)	183,5 (178,5)	full=368
155	(150)	181 (176)	207 (202)	17,5	40	25	160 (155)	183,5 (178,5)	full=390
155	(150)	181 (176)	207 (202)	17,5	40	25	160 (155)	183,5 (178,5)	full=423
155	(150)	181 (176)	207 (202)	17,5	40	25	160 (155)	183,5 (178,5)	full=445
155	(150)	181 (176)	207 (202)	17,5	40	25	160 (155)	183,5 (178,5)	full=463
155	(150)	181 (176)	207 (202)	17,5	40	25	160 (155)	183,5 (178,5)	full=485
155	(150)	181 (176)	207 (202)	17,5	40	25	160 (155)	183,5 (178,5)	full=516
155	(150)	181 (176)	207 (202)	17,5	40	25	160 (155)	183,5 (178,5)	full=542
155	(150)	181 (176)	207 (202)	17,5	40	25	160 (155)	183,5 (178,5)	full=558
155	(150)	181 (176)	207 (202)	17,5	40	25	160 (155)	183,5 (178,5)	full=585
160		186	212	17,5	30	40	165	188,5	full=111
160		186	212	17,5	30	40	165	188,5	full=140
160		186	212	17,5	30	40	165	188,5	full=171
160		186	212	17,5	30	40	165	188,5	full=200
160		186	212	17,5	30	40	165	188,5	full=233
160		186	212	17,5	30	40	165	188,5	full=266
160		186	212	17,5	30	40	165	188,5	full=304

SHUTON-IPIRANGA advises to use the dimensions of the tables, although it is possible to manufacture ball screw with other dimensions. In brackets () second options.

Smaller nut diameters than the first option of the table can reduce the rigidity of the assembly between 5 and 10%. Please consult SHUTON-IPIRANGA.

High Load HDL TS Single nut, DN up to 110.000

Ball screw reference	Number of starts	Nominal diameter (mm)	Lead (mm)	Ball Diameter (mm)	Root diameter (mm)	Circuits	Dynamic load capacity	Static load capacity	Peak load CO-CO TR-TR 'TS'	Nut length
	$l/2$	d_0	P_h	D_w	d_2	i	C_a [kN]	C_{oa} [kN]	F_{max} [kN]	$L_{n,std}$ [mm]
HDL TSB-U 100-20-15-9	1	100	20	15,875	87,1	9	755,2	2341,7	480	228
HDL TSB-U 100-20-15-10	1	100	20	15,875	87,1	10	827,2	2604,8	510	248
HDL TSB-B 100-20-15-11	1	100	20	15,875	87,1	11	867,7	2723,2	590	283
HDL TSB-B 100-20-15-12	1	100	20	15,875	87,1	12	932,8	2960	630	303
HDL TSB-B 100-20-15-13	1	100	20	15,875	87,1	13	1005,3	3236,3	690	323
HDL TSB-B 100-20-15-14	1	100	20	15,875	87,1	14	1076,9	3512,5	740	343
HDL TSB-B 100-20-15-15	1	100	20	15,875	87,1	15	1147,8	3788,8	780	361
HDL TSB-B 100-20-15-16	1	100	20	15,875	87,1	16	1194,2	3946,6	790	382
HDL TSB-B 100-20-15-17	1	100	20	15,875	87,1	17	1271,8	4262,4	850	402
HDL TSB-B 100-20-15-18	1	100	20	15,875	87,1	18	1338,3	4525,5	880	422
HDL TSB-B 100-20-15-19	1	100	20	15,875	87,1	19	1404,3	4788,6	910	442
HDL TSB-B 100-20-15-20	1	100	20	15,875	87,1	20	1469,7	5051,7	940	462
HDL TSB-U 100-25-15-2	1	100	25	15,875	87,1	2	201	446,8	100	97
HDL TSB-U 100-25-15-3	1	100	25	15,875	87,1	3	285,4	722,8	170	122
HDL TSB-U 100-25-15-4	1	100	25	15,875	87,1	4	366,1	985,6	220	147
HDL TSB-U 100-25-15-5	1	100	25	15,875	87,1	5	448,3	1261,6	280	172
HDL TSB-U 100-25-15-6	1	100	25	15,875	87,1	6	525,5	1524,4	340	197
HDL TSB-U 100-25-15-7	1	100	25	15,875	87,1	7	604,1	1800,4	390	222
HDL TSB-U 100-25-15-8	1	100	25	15,875	87,1	8	678,3	2063,2	430	247
HDL TSB-U 100-25-15-9	1	100	25	15,875	87,1	9	754,2	2339,2	470	272
HDL TSB-B 100-25-15-10	1	100	25	15,875	87,1	10	809,3	2523,2	540	312
HDL TSB-B 100-25-15-11	1	100	25	15,875	87,1	11	866,5	2720,3	570	341
HDL TSB-B 100-25-15-12	1	100	25	15,875	87,1	12	931,5	2956,8	610	364
HDL TSB-B 100-25-15-13	1	100	25	15,875	87,1	13	1003,9	3232,8	660	389
HDL TSB-B 100-25-15-14	1	100	25	15,875	87,1	14	1075,4	3508,8	690	414
HDL TSB-B 100-25-15-15	1	100	25	15,875	87,1	15	1146,2	3784,8	720	439
HDL TSB-B 100-25-15-16	1	100	25	15,875	87,1	16	1192,6	3942,5	730	466
HDL TSB-B 100-25-15-17	1	100	25	15,875	87,1	17	1270,1	4257,8	770	485
HDL TSB-B 100-25-19-2	1	100	25	19,05	84,1	2	259,3	541,1	130	105
HDL TSB-B 100-25-19-3	1	100	25	19,05	84,1	3	366,6	869,6	210	130
HDL TSB-B 100-25-19-4	1	100	25	19,05	84,1	4	473,5	1198,1	280	155
HDL TSB-B 100-25-19-5	1	100	25	19,05	84,1	5	578	1526,6	350	180
HDL TSB-B 100-25-19-6	1	100	25	19,05	84,1	6	680,2	1855,1	420	205
HDL TSB-B 100-25-19-7	1	100	25	19,05	84,1	7	780,2	2183,6	480	230
HDL TSB-B 100-25-19-8	1	100	25	19,05	84,1	8	851,1	2396,2	540	268
HDL TSB-B 100-25-19-9	1	100	25	19,05	84,1	9	952,6	2744	610	293

- C_a and C_{oa} : Modified static and dynamic load capacities, calculated according to DIN 69051/4 standard and ISO3408/5. See Technical description catalogue.

- Check with SHUTON-IPIRANGA in case higher loads or more adjusted nut dimensions are required.

- Check external maximum axial force in the two senses.

For the indicated leads, in case C_a and C_{oa} requirements is lower, there is possibility of smaller size balls.

Maximum force (Peak load CO-CO and TR-TR) calculated with the flange/nut clamping in opposite position to the main support of the shaft, with same load type (traction or compression) in both nut and shaft. For same-side clamping, so different type of load, contact SHUTON-IPIRANGA as peak load is lower.

Nut dimensions									Grease quantity TS
$D_{1, std}$	$D_{1, min}$	D_4	D_6	D_5	L_7	L_1	L_8	L_9	$Q_{Gr} [cm^3]$
160		186	212	17,5	30	40	165	188,5	full=341
160		186	212	17,5	30	40	165	188,5	full=385
165	(160)	191 (186)	217 (212)	17,5	45	40	170 (165)	193,5 (188,5)	full=515
165	(160)	191 (186)	217 (212)	17,5	45	40	170 (165)	193,5 (188,5)	full=552
165	(160)	191 (186)	217 (212)	17,5	45	40	170 (165)	193,5 (188,5)	full=577
165	(160)	191 (186)	217 (212)	17,5	45	40	170 (165)	193,5 (188,5)	full=608
165	(160)	191 (186)	217 (212)	17,5	45	40	170 (165)	193,5 (188,5)	full=632
165	(160)	191 (186)	217 (212)	17,5	45	40	170 (165)	193,5 (188,5)	full=679
165	(160)	191 (186)	217 (212)	17,5	45	40	170 (165)	193,5 (188,5)	full=698
165	(160)	191 (186)	217 (212)	17,5	45	40	170 (165)	193,5 (188,5)	full=733
165	(160)	191 (186)	217 (212)	17,5	45	40	170 (165)	193,5 (188,5)	full=760
165	(160)	191 (186)	217 (212)	17,5	45	40	170 (165)	193,5 (188,5)	full=795
160		186	212	17,5	30	40	165	188,5	full=113
160		186	212	17,5	30	40	165	188,5	full=147
160		186	212	17,5	30	40	165	188,5	full=184
160		186	212	17,5	30	40	165	188,5	full=218
160		186	212	17,5	30	40	165	188,5	full=256
160		186	212	17,5	30	40	165	188,5	full=295
160		186	212	17,5	30	40	165	188,5	full=338
160		186	212	17,5	30	40	165	188,5	full=380
165	(160)	191 (186)	217 (212)	17,5	45	40	170 (165)	193,5 (188,5)	full=508
165	(160)	191 (186)	217 (212)	17,5	45	40	170 (165)	193,5 (188,5)	full=560
165	(160)	191 (186)	217 (212)	17,5	45	40	170 (165)	193,5 (188,5)	full=597
165	(160)	191 (186)	217 (212)	17,5	45	40	170 (165)	193,5 (188,5)	full=627
165	(160)	191 (186)	217 (212)	17,5	45	40	170 (165)	193,5 (188,5)	full=663
165	(160)	191 (186)	217 (212)	17,5	45	40	170 (165)	193,5 (188,5)	full=699
165	(160)	191 (186)	217 (212)	17,5	45	40	170 (165)	193,5 (188,5)	full=754
165	(160)	191 (186)	217 (212)	17,5	45	40	170 (165)	193,5 (188,5)	full=760
175	(170)	201 (196)	227 (222)	17,5	50	40	180 (175)	203,5 (198,5)	full=261
175	(170)	201 (196)	227 (222)	17,5	50	40	180 (175)	203,5 (198,5)	full=302
175	(170)	201 (196)	227 (222)	17,5	50	40	180 (175)	203,5 (198,5)	full=348
175	(170)	201 (196)	227 (222)	17,5	50	40	180 (175)	203,5 (198,5)	full=393
175	(170)	201 (196)	227 (222)	17,5	50	40	180 (175)	203,5 (198,5)	full=439
175	(170)	201 (196)	227 (222)	17,5	50	40	180 (175)	203,5 (198,5)	full=491
175	(170)	201 (196)	227 (222)	17,5	50	40	180 (175)	203,5 (198,5)	full=592
175	(170)	201 (196)	227 (222)	17,5	50	40	180 (175)	203,5 (198,5)	full=634

SHUTON-IPIRANGA advises to use the dimensions of the tables, although it is possible to manufacture ball screw with other dimensions. In brackets () second options.

Smaller nut diameters than the first option of the table can reduce the rigidity of the assembly between 5 and 10%. Please consult SHUTON-IPIRANGA.

High Load HDL TS Single nut, DN up to 110.000

Ball screw reference	Number of starts	Nominal diameter (mm)	Lead (mm)	Ball Diameter (mm)	Root diameter (mm)	Circuits	Dynamic load capacity	Static load capacity	Peak load CO-CO TR-TR 'TS'	Nut length
	$l/2$	d_0	P_h	D_w	d_2	i	C_a [kN]	C_{oa} [kN]	F_{max} [kN]	$L_{n, std}$ [mm]
HDL TSB-B 100-25-19-10	1	100	25	19,05	84,1	10	1043,6	3053,2	670	318
HDL TSB-B 100-25-19-11	1	100	25	19,05	84,1	11	1142	3401	730	343
HDL TSB-B 100-25-19-12	1	100	25	19,05	84,1	12	1230,6	3710,2	780	366
HDL TSB-B 100-25-19-13	1	100	25	19,05	84,1	13	1326,5	4058	820	391
HDL TSB-B 100-25-19-14	1	100	25	19,05	84,1	14	1413,1	4367,2	850	416
HDL TSB-B 100-25-19-15	1	100	25	19,05	84,1	15	1478	4579,7	900	445
HDL TSB-B 100-25-19-16	1	100	25	19,05	84,1	16	1571,4	4927,6	940	470
HDL TSB-B 100-30-19-2	1	100	30	19,05	84,1	2	258,9	540,4	130	115
HDL TSB-B 100-30-19-3	1	100	30	19,05	84,1	3	366	868,4	210	145
HDL TSB-B 100-30-19-4	1	100	30	19,05	84,1	4	472,7	1196,5	280	175
HDL TSB-B 100-30-19-5	1	100	30	19,05	84,1	5	577,1	1524,6	350	205
HDL TSB-B 100-30-19-6	1	100	30	19,05	84,1	6	679	1852,7	420	235
HDL TSB-B 100-30-19-7	1	100	30	19,05	84,1	7	783,5	2200,1	480	265
HDL TSB-B 100-30-19-8	1	100	30	19,05	84,1	8	849,7	2393,1	530	310
HDL TSB-B 100-30-19-9	1	100	30	19,05	84,1	9	951	2740,4	590	340
HDL TSB-B 100-30-19-10	1	100	30	19,05	84,1	10	1041,8	3049,2	640	368
HDL TSB-B 100-30-19-11	1	100	30	19,05	84,1	11	1140,1	3396,6	700	398
HDL TSB-B 100-30-19-12	1	100	30	19,05	84,1	12	1228,5	3705,4	740	428
HDL TSB-B 100-30-19-13	1	100	30	19,05	84,1	13	1324,3	4052,8	770	458
HDL TSB-B 100-30-19-14	1	100	30	19,05	84,1	14	1419	4400,1	800	480
HDL TSB-B 100-30-25-2	1	100	30	25,4	78,7	2	362,2	674,9	150	126
HDL TSB-B 100-30-25-3	1	100	30	25,4	78,7	3	528,4	1136,7	240	156
HDL TSB-B 100-30-25-4	1	100	30	25,4	78,7	4	691,8	1598,4	340	186
HDL TSB-B 100-30-25-5	1	100	30	25,4	78,7	5	851,1	2060,2	420	216
HDL TSB-B 100-30-25-6	1	100	30	25,4	78,7	6	1006,4	2521,9	500	246
HDL TSB-B 100-30-25-7	1	100	30	25,4	78,7	7	1102,4	2770,6	560	291
HDL TSB-B 100-30-25-8	1	100	30	25,4	78,7	8	1243,6	3196,8	640	321
HDL TSB-B 100-30-25-9	1	100	30	25,4	78,7	9	1400,3	3694,1	720	351
HDL TSB-B 100-30-25-10	1	100	30	25,4	78,7	10	1536,5	4120,4	770	379
HDL TSB-B 100-30-25-11	1	100	30	25,4	78,7	11	1688,2	4617,6	840	409
HDL TSB-B 100-30-25-12	1	100	30	25,4	78,7	12	1820,7	5043,9	880	439
HDL TSB-B 100-30-25-13	1	100	30	25,4	78,7	13	1917,7	5328,1	920	474
HDL TSB(2S)-U 100-32-12-2	2	100	32	12,7	90	2	231,5	608,9	130	117
HDL TSB(2S)-U 100-32-12-3	2	100	32	12,7	90	3	320,3	947,2	210	149
HDL TSB(2S)-U 100-32-12-4	2	100	32	12,7	90	4	412,4	1299	270	181
HDL TSB(2S)-U 100-32-12-5	2	100	32	12,7	90	5	502,6	1650,8	340	213

- C_a and C_{oa} : Modified static and dynamic load capacities, calculated according to DIN 69051/4 standard and ISO3408/5. See Technical description catalogue.

- Check with SHUTON-IPIRANGA in case higher loads or more adjusted nut dimensions are required.

- Check external maximum axial force in the two senses.

For the indicated leads, in case C_a and C_{oa} requirements is lower, there is possibility of smaller size balls.

Maximum force (Peak load CO-CO and TR-TR) calculated with the flange/nut clamping in opposite position to the main support of the shaft, with same load type (traction or compression) in both nut and shaft. For same-side clamping, so different type of load, contact SHUTON-IPIRANGA as peak load is lower.

Nut dimensions									Grease quantity TS
$D_{1, std}$	$D_{1, min}$	D_4	D_6	D_5	L_7	L_1	L_8	L_9	$Q_{Gr} [cm^3]$
175	(170)	201 (196)	227 (222)	17,5	50	40	180 (175)	203,5 (198,5)	full=683
175	(170)	201 (196)	227 (222)	17,5	50	40	180 (175)	203,5 (198,5)	full=725
175	(170)	201 (196)	227 (222)	17,5	50	40	180 (175)	203,5 (198,5)	full=766
175	(170)	201 (196)	227 (222)	17,5	50	40	180 (175)	203,5 (198,5)	full=815
175	(170)	201 (196)	227 (222)	17,5	50	40	180 (175)	203,5 (198,5)	full=872
175	(170)	201 (196)	227 (222)	17,5	50	40	180 (175)	203,5 (198,5)	full=930
175	(170)	201 (196)	227 (222)	17,5	50	40	180 (175)	203,5 (198,5)	full=975
175	(170)	201 (196)	227 (222)	17,5	50	40	180 (175)	203,5 (198,5)	full=254
175	(170)	201 (196)	227 (222)	17,5	50	40	180 (175)	203,5 (198,5)	full=301
175	(170)	201 (196)	227 (222)	17,5	50	40	180 (175)	203,5 (198,5)	full=353
175	(170)	201 (196)	227 (222)	17,5	50	40	180 (175)	203,5 (198,5)	full=404
175	(170)	201 (196)	227 (222)	17,5	50	40	180 (175)	203,5 (198,5)	full=455
175	(170)	201 (196)	227 (222)	17,5	50	40	180 (175)	203,5 (198,5)	full=510
175	(170)	201 (196)	227 (222)	17,5	50	40	180 (175)	203,5 (198,5)	full=621
175	(170)	201 (196)	227 (222)	17,5	50	40	180 (175)	203,5 (198,5)	full=669
175	(170)	201 (196)	227 (222)	17,5	50	40	180 (175)	203,5 (198,5)	full=717
175	(170)	201 (196)	227 (222)	17,5	50	40	180 (175)	203,5 (198,5)	full=764
175	(170)	201 (196)	227 (222)	17,5	50	40	180 (175)	203,5 (198,5)	full=819
175	(170)	201 (196)	227 (222)	17,5	50	40	180 (175)	203,5 (198,5)	full=874
175	(170)	201 (196)	227 (222)	17,5	50	40	180 (175)	203,5 (198,5)	full=901
190		223	255	22	60	40	195	225	full=482
190		223	255	22	60	40	195	225	full=553
190		223	255	22	60	40	195	225	full=624
190		223	255	22	60	40	195	225	full=703
190		223	255	22	60	40	195	225	full=783
190		223	255	22	60	40	195	225	full=975
190		223	255	22	60	40	195	225	full=1045
190		223	255	22	60	40	195	225	full=1116
190		223	255	22	60	40	195	225	full=1193
190		223	255	22	60	40	195	225	full=1263
190		223	255	22	60	40	195	225	full=1351
190		223	255	22	60	40	195	225	full=1468
150		176	202	17,5	30	25	155	178,5	full=154
150		176	202	17,5	30	25	155	178,5	full=191
150		176	202	17,5	30	25	155	178,5	full=230
150		176	202	17,5	30	25	155	178,5	full=270

SHUTON-IPIRANGA advises to use the dimensions of the tables, although it is possible to manufacture ball screw with other dimensions. In brackets () second options.

Smaller nut diameters than the first option of the table can reduce the rigidity of the assembly between 5 and 10%. Please consult SHUTON-IPIRANGA.

High Load HDL TS Single nut, DN up to 110.000

Ball screw reference	Number of starts	Nominal diameter (mm)	Lead (mm)	Ball Diameter (mm)	Root diameter (mm)	Circuits	Dynamic load capacity	Static load capacity	Peak load CO-CO TR-TR 'TS'	Nut length
	$1/2$	d_0	P_h	D_w	d_2	i	C_a [kN]	C_{oa} [kN]	F_{max} [kN]	$L_{n, std}$ [mm]
HDL TSB(2S)-U 100-32-12-6	2	100	32	12,7	90	6	588	1989,1	400	245
HDL TSB(2S)-U 100-32-12-7	2	100	32	12,7	90	7	674,4	2340,9	460	277
HDL TSB(2S)-B 100-32-12-8	2	100	32	12,7	90	8	741,3	2598	520	317
HDL TSB(2S)-B 100-32-12-9	2	100	32	12,7	90	9	804,7	2841,5	560	355
HDL TSB(2S)-B 100-32-12-10	2	100	32	12,7	90	10	889,9	3206,8	610	385
HDL TSB(2S)-B 100-32-12-11	2	100	32	12,7	90	11	966,4	3531,6	650	417
HDL TSB(2S)-B 100-32-12-12	2	100	32	12,7	90	12	1049,3	3896,9	690	449
HDL TSB(2S)-B 100-32-12-13	2	100	32	12,7	90	13	1114,4	4167,6	720	483
HDL TSB(2S)-B 100-32-12-14	2	100	32	12,7	90	14	1188,3	4492,3	740	515
HDL TSB(2S)-B 100-32-12-15	2	100	32	12,7	90	15	1271	4871,2	750	539
HDL TSB-B 100-32-25-2	1	100	32	25,4	78,7	2	362	674,5	150	130
HDL TSB-B 100-32-25-3	1	100	32	25,4	78,7	3	528	1136	240	162
HDL TSB-B 100-32-25-4	1	100	32	25,4	78,7	4	691,3	1597,5	340	194
HDL TSB-B 100-32-25-5	1	100	32	25,4	78,7	5	850,4	2059	420	226
HDL TSB-B 100-32-25-6	1	100	32	25,4	78,7	6	1005,6	2520,5	500	258
HDL TSB-B 100-32-25-7	1	100	32	25,4	78,7	7	1101,6	2769	550	306
HDL TSB-B 100-32-25-8	1	100	32	25,4	78,7	8	1242,6	3195	630	338
HDL TSB-B 100-32-25-9	1	100	32	25,4	78,7	9	1399,2	3692	710	370
HDL TSB-B 100-32-25-10	1	100	32	25,4	78,7	10	1535,4	4118	760	400
HDL TSB-B 100-32-25-11	1	100	32	25,4	78,7	11	1687	4615	820	432
HDL TSB-B 100-32-25-12	1	100	32	25,4	78,7	12	1819,3	5041	860	464
HDL TSB(2S)-U 100-40-12-2	2	100	40	12,7	90	2	230,7	607,2	130	127
HDL TSB(2S)-U 100-40-12-3	2	100	40	12,7	90	3	322,2	958,1	210	167
HDL TSB(2S)-U 100-40-12-4	2	100	40	12,7	90	4	411	1295,5	270	207
HDL TSB(2S)-U 100-40-12-5	2	100	40	12,7	90	5	500,8	1646,3	330	247
HDL TSB(2S)-U 100-40-12-6	2	100	40	12,7	90	6	588,6	1997,2	390	287
HDL TSB(2S)-B 100-40-12-7	2	100	40	12,7	90	7	653,8	2240,1	440	343
HDL TSB(2S)-B 100-40-12-8	2	100	40	12,7	90	8	738,7	2590,9	490	381
HDL TSB(2S)-B 100-40-12-9	2	100	40	12,7	90	9	809,4	2874,3	530	428
HDL TSB(2S)-B 100-40-12-10	2	100	40	12,7	90	10	886,8	3198,1	560	468
HDL TSB(2S)-B 100-40-12-11	2	100	40	12,7	90	11	970,4	3562,5	580	508
HDL TSB(2S)-B 100-40-12-12	2	100	40	12,7	90	12	1045,6	3886,4	590	535
HDL TSB(2S)-U 100-40-15-2	2	100	40	15,875	87,1	2	316	763,1	180	135
HDL TSB(2S)-U 100-40-15-3	2	100	40	15,875	87,1	3	440,2	1199,1	270	175
HDL TSB(2S)-U 100-40-15-4	2	100	40	15,875	87,1	4	569,7	1657	370	215
HDL TSB(2S)-U 100-40-15-5	2	100	40	15,875	87,1	5	691,4	2093	460	255

- C_a and C_{oa} : Modified static and dynamic load capacities, calculated according to DIN 69051/4 standard and ISO3408/5. See Technical description catalogue.

- Check with SHUTON-IPIRANGA in case higher loads or more adjusted nut dimensions are required.

- Check external maximum axial force in the two senses.

For the indicated leads, in case C_a and C_{oa} requirements is lower, there is possibility of smaller size balls.

Maximum force (Peak load CO-CO and TR-TR) calculated with the flange/nut clamping in opposite position to the main support of the shaft, with same load type (traction or compression) in both nut and shaft. For same-side clamping, so different type of load, contact SHUTON-IPIRANGA as peak load is lower.

Nut dimensions									Grease quantity TS
$D_{1, std}$	$D_{1, min}$	D_4	D_6	D_5	L_7	L_1	L_8	L_9	$Q_{Gr} [cm^3]$
150		176	202	17,5	30	25	155	178,5	full=314
150		176	202	17,5	30	25	155	178,5	full=357
155	(150)	181 (176)	207 (202)	17,5	40	25	160 (155)	183,5 (178,5)	full=447
155	(150)	181 (176)	207 (202)	17,5	40	25	160 (155)	183,5 (178,5)	full=510
155	(150)	181 (176)	207 (202)	17,5	40	25	160 (155)	183,5 (178,5)	full=542
155	(150)	181 (176)	207 (202)	17,5	40	25	160 (155)	183,5 (178,5)	full=586
155	(150)	181 (176)	207 (202)	17,5	40	25	160 (155)	183,5 (178,5)	full=623
155	(150)	181 (176)	207 (202)	17,5	40	25	160 (155)	183,5 (178,5)	full=672
155	(150)	181 (176)	207 (202)	17,5	40	25	160 (155)	183,5 (178,5)	full=718
155	(150)	181 (176)	207 (202)	17,5	40	25	160 (155)	183,5 (178,5)	full=725
190		223	255	22	60	40	195	225	full=475
190		223	255	22	60	40	195	225	full=549
190		223	255	22	60	40	195	225	full=623
190		223	255	22	60	40	195	225	full=705
190		223	255	22	60	40	195	225	full=787
190		223	255	22	60	40	195	225	full=984
190		223	255	22	60	40	195	225	full=1058
190		223	255	22	60	40	195	225	full=1132
190		223	255	22	60	40	195	225	full=1212
190		223	255	22	60	40	195	225	full=1285
190		223	255	22	60	40	195	225	full=1376
150		176	202	17,5	30	25	155	178,5	full=156
150		176	202	17,5	30	25	155	178,5	full=199
150		176	202	17,5	30	25	155	178,5	full=249
150		176	202	17,5	30	25	155	178,5	full=296
150		176	202	17,5	30	25	155	178,5	full=346
155	(150)	181 (176)	207 (202)	17,5	40	25	160 (155)	183,5 (178,5)	full=460
155	(150)	181 (176)	207 (202)	17,5	40	25	160 (155)	183,5 (178,5)	full=500
155	(150)	181 (176)	207 (202)	17,5	40	25	160 (155)	183,5 (178,5)	full=565
155	(150)	181 (176)	207 (202)	17,5	40	25	160 (155)	183,5 (178,5)	full=616
155	(150)	181 (176)	207 (202)	17,5	40	25	160 (155)	183,5 (178,5)	full=662
155	(150)	181 (176)	207 (202)	17,5	40	25	160 (155)	183,5 (178,5)	full=682
160		186	212	17,5	30	40	165	188,5	full=165
160		186	212	17,5	30	40	165	188,5	full=227
160		186	212	17,5	30	40	165	188,5	full=286
160		186	212	17,5	30	40	165	188,5	full=348

SHUTON-IPIRANGA advises to use the dimensions of the tables, although it is possible to manufacture ball screw with other dimensions. In brackets () second options.

Smaller nut diameters than the first option of the table can reduce the rigidity of the assembly between 5 and 10%. Please consult SHUTON-IPIRANGA.

High Load HDL TS Single nut, DN up to 110.000

Ball screw reference	Number of starts	Nominal diameter (mm)	Lead (mm)	Ball Diameter (mm)	Root diameter (mm)	Circuits	Dynamic load capacity	Static load capacity	Peak load CO-CO TR-TR 'TS'	Nut length
	$l/2$	d_0	P_h	D_w	d_2	i	C_a [kN]	C_{oa} [kN]	F_{max} [kN]	L_{nstd} [mm]
HDL TSB(2S)-U 100-40-15-6	2	100	40	15,875	87,1	6	815,2	2550,9	540	295
HDL TSB(2S)-B 100-40-15-7	2	100	40	15,875	87,1	7	909	2877,9	610	351
HDL TSB(2S)-B 100-40-15-8	2	100	40	15,875	87,1	8	1023,9	3314	670	389
HDL TSB(2S)-B 100-40-15-9	2	100	40	15,875	87,1	9	1137	3750	720	429
HDL TSB(2S)-B 100-40-15-10	2	100	40	15,875	87,1	10	1248,3	4186	780	469
HDL TSB(2S)-B 100-40-15-11	2	100	40	15,875	87,1	11	1336,6	4513,1	800	503
HDL TSB(2S)-B 100-40-15-12	2	100	40	15,875	87,1	12	1449,5	4970,9	830	543
HDL TSB(2S)-U 100-50-15-2	2	100	50	15,875	87,1	2	314,3	759,9	180	149
HDL TSB(2S)-U 100-50-15-3	2	100	50	15,875	87,1	3	443,1	1215,8	270	199
HDL TSB(2S)-U 100-50-15-4	2	100	50	15,875	87,1	4	566,6	1650	360	249
HDL TSB(2S)-U 100-50-15-5	2	100	50	15,875	87,1	5	692,4	2106	440	299
HDL TSB(2S)-B 100-50-15-6	2	100	50	15,875	87,1	6	787,5	2431,6	500	372
HDL TSB(2S)-B 100-50-15-7	2	100	50	15,875	87,1	7	904	2865,9	570	422
HDL TSB(2S)-B 100-50-15-8	2	100	50	15,875	87,1	8	1018,4	3300,1	610	472
HDL TSB(2S)-B 100-50-15-9	2	100	50	15,875	87,1	9	1113,2	3647,5	640	514
HDL TSB(2S)-B 100-50-19-2	2	100	50	19,05	84,1	2	397,8	893,9	210	157
HDL TSB(2S)-B 100-50-19-3	2	100	50	19,05	84,1	3	562,4	1436,7	340	207
HDL TSB(2S)-B 100-50-19-4	2	100	50	19,05	84,1	4	734,2	2011,3	460	257
HDL TSB(2S)-B 100-50-19-5	2	100	50	19,05	84,1	5	848,9	2362,5	530	332
HDL TSB(2S)-B 100-50-19-6	2	100	50	19,05	84,1	6	999,5	2873,4	620	380
HDL TSB(2S)-B 100-50-19-7	2	100	50	19,05	84,1	7	1161,3	3448	700	430
HDL TSB(2S)-B 100-50-19-8	2	100	50	19,05	84,1	8	1319,7	4022,7	770	480
HDL TSB(2S)-B 100-50-19-9	2	100	50	19,05	84,1	9	1412,9	4310	790	526
HDL TSB-U 120-16-12-2	1	120	16	12,7	110	2	162,3	443,4	95	79
HDL TSB-U 120-16-12-3	1	120	16	12,7	110	3	226,4	698	150	95
HDL TSB-U 120-16-12-4	1	120	16	12,7	110	4	288,9	944,3	200	111
HDL TSB-U 120-16-12-5	1	120	16	12,7	110	5	351,8	1198,9	250	127
HDL TSB-U 120-16-12-6	1	120	16	12,7	110	6	411,7	1445,2	300	143
HDL TSB-U 120-16-12-7	1	120	16	12,7	110	7	472	1699,8	350	159
HDL TSB-B 120-16-12-8	1	120	16	12,7	110	8	511,7	1847,6	400	182
HDL TSB-B 120-16-12-9	1	120	16	12,7	110	9	568,7	2093,9	450	198
HDL TSB-B 120-16-12-10	1	120	16	12,7	110	10	617,6	2299,2	490	215
HDL TSB-B 120-16-12-11	1	120	16	12,7	110	11	670,2	2529,1	530	231
HDL TSB-B 120-16-12-12	1	120	16	12,7	110	12	727,9	2791,9	580	247
HDL TSB-B 120-16-12-13	1	120	16	12,7	110	13	774,9	2997,2	630	264
HDL TSB-B 120-16-12-14	1	120	16	12,7	110	14	828,6	3243,5	670	280

- C_a and C_{oa} : Modified static and dynamic load capacities, calculated according to DIN 69051/4 standard and ISO3408/5. See Technical description catalogue.

- Check with SHUTON-IPIRANGA in case higher loads or more adjusted nut dimensions are required.

- Check external maximum axial force in the two senses.

For the indicated leads, in case C_a and C_{oa} requirements is lower, there is possibility of smaller size balls.

Maximum force (Peak load CO-CO and TR-TR) calculated with the flange/nut clamping in opposite position to the main support of the shaft, with same load type (traction or compression) in both nut and shaft. For same-side clamping, so different type of load, contact SHUTON-IPIRANGA as peak load is lower.

Nut dimensions									Grease quantity TS
$D_{1, std}$	$D_{1, min}$	D_4	D_6	D_5	L_7	L_1	L_8	L_9	$Q_{Gr} [cm^3]$
160		186	212	17,5	30	40	165	188,5	full=411
165	(160)	191 (186)	217 (212)	17,5	45	40	170 (165)	193,5 (188,5)	full=629
165	(160)	191 (186)	217 (212)	17,5	45	40	170 (165)	193,5 (188,5)	full=693
165	(160)	191 (186)	217 (212)	17,5	45	40	170 (165)	193,5 (188,5)	full=756
165	(160)	191 (186)	217 (212)	17,5	45	40	170 (165)	193,5 (188,5)	full=818
165	(160)	191 (186)	217 (212)	17,5	45	40	170 (165)	193,5 (188,5)	full=868
165	(160)	191 (186)	217 (212)	17,5	45	40	170 (165)	193,5 (188,5)	full=931
160		186	212	17,5	30	40	165	188,5	full=177
160		186	212	17,5	30	40	165	188,5	full=246
160		186	212	17,5	30	40	165	188,5	full=320
160		186	212	17,5	30	40	165	188,5	full=389
165	(160)	191 (186)	217 (212)	17,5	45	40	170 (165)	193,5 (188,5)	full=624
165	(160)	191 (186)	217 (212)	17,5	45	40	170 (165)	193,5 (188,5)	full=689
165	(160)	191 (186)	217 (212)	17,5	45	40	170 (165)	193,5 (188,5)	full=771
165	(160)	191 (186)	217 (212)	17,5	45	40	170 (165)	193,5 (188,5)	full=829
175	(170)	201 (196)	227 (222)	17,5	50	40	180 (175)	203,5 (198,5)	full=369
175	(170)	201 (196)	227 (222)	17,5	50	40	180 (175)	203,5 (198,5)	full=454
175	(170)	201 (196)	227 (222)	17,5	50	40	180 (175)	203,5 (198,5)	full=539
175	(170)	201 (196)	227 (222)	17,5	50	40	180 (175)	203,5 (198,5)	full=754
175	(170)	201 (196)	227 (222)	17,5	50	40	180 (175)	203,5 (198,5)	full=845
175	(170)	201 (196)	227 (222)	17,5	50	40	180 (175)	203,5 (198,5)	full=930
175	(170)	201 (196)	227 (222)	17,5	50	40	180 (175)	203,5 (198,5)	full=1015
175	(170)	201 (196)	227 (222)	17,5	50	40	180 (175)	203,5 (198,5)	full=1127
170		196	222	17,5	30	25	175	198,5	full=100
170		196	222	17,5	30	25	175	198,5	full=122
170		196	222	17,5	30	25	175	198,5	full=146
170		196	222	17,5	30	25	175	198,5	full=170
170		196	222	17,5	30	25	175	198,5	full=196
170		196	222	17,5	30	25	175	198,5	full=222
175	(170)	201 (196)	227 (222)	17,5	40	40	180 (175)	203,5 (198,5)	full=320
175	(170)	201 (196)	227 (222)	17,5	40	40	180 (175)	203,5 (198,5)	full=344
175	(170)	201 (196)	227 (222)	17,5	40	40	180 (175)	203,5 (198,5)	full=374
175	(170)	201 (196)	227 (222)	17,5	40	40	180 (175)	203,5 (198,5)	full=401
175	(170)	201 (196)	227 (222)	17,5	40	40	180 (175)	203,5 (198,5)	full=420
175	(170)	201 (196)	227 (222)	17,5	40	40	180 (175)	203,5 (198,5)	full=449
175	(170)	201 (196)	227 (222)	17,5	40	40	180 (175)	203,5 (198,5)	full=475

SHUTON-IPIRANGA advises to use the dimensions of the tables, although it is possible to manufacture ball screw with other dimensions. In brackets () second options.

Smaller nut diameters than the first option of the table can reduce the rigidity of the assembly between 5 and 10%. Please consult SHUTON-IPIRANGA.

High Load HDL TS Single nut, DN up to 110.000

Ball screw reference	Number of starts	Nominal diameter (mm)	Lead (mm)	Ball Diameter (mm)	Root diameter (mm)	Circuits	Dynamic load capacity	Static load capacity	Peak load CO-CO TR-TR 'TS'	Nut length
	$l/2$	d_0	P_h	D_w	d_2	i	C_a [kN]	C_{oa} [kN]	F_{max} [kN]	$L_{n,std}$ [mm]
HDL TSB-B 120-16-12-15	1	120	16	12,7	110	15	881,6	3489,9	720	296
HDL TSB-B 120-16-12-16	1	120	16	12,7	110	16	927,3	3695,1	750	313
HDL TSB-B 120-16-12-17	1	120	16	12,7	110	17	979,5	3941,5	790	329
HDL TSB-B 120-16-12-18	1	120	16	12,7	110	18	1031,2	4187,8	820	345
HDL TSB-U 120-20-12-2	1	120	20	12,7	110	2	162,2	443,2	95	100
HDL TSB-U 120-20-12-3	1	120	20	12,7	110	3	226,2	697,6	150	120
HDL TSB-U 120-20-12-4	1	120	20	12,7	110	4	288,7	943,9	200	140
HDL TSB-U 120-20-12-5	1	120	20	12,7	110	5	351,6	1198,3	250	160
HDL TSB-U 120-20-12-6	1	120	20	12,7	110	6	411,5	1444,5	300	180
HDL TSB-B 120-20-12-7	1	120	20	12,7	110	7	453,3	1600,5	340	197
HDL TSB-B 120-20-12-8	1	120	20	12,7	110	8	511,3	1846,7	400	217
HDL TSB-B 120-20-12-9	1	120	20	12,7	110	9	568,4	2092,9	440	237
HDL TSB-B 120-20-12-10	1	120	20	12,7	110	10	617,2	2298,1	480	258
HDL TSB-B 120-20-12-11	1	120	20	12,7	110	11	669,8	2527,9	520	278
HDL TSB-B 120-20-12-12	1	120	20	12,7	110	12	727,4	2790,5	570	298
HDL TSB-B 120-20-12-13	1	120	20	12,7	110	13	774,5	2995,7	610	319
HDL TSB-B 120-20-12-14	1	120	20	12,7	110	14	828	3242	640	339
HDL TSB-B 120-20-12-15	1	120	20	12,7	110	15	881,1	3488,2	680	357
HDL TSB-U 120-20-15-2	1	120	20	15,875	107,1	2	223,4	558	130	89
HDL TSB-U 120-20-15-3	1	120	20	15,875	107,1	3	314,4	890,1	210	109
HDL TSB-U 120-20-15-4	1	120	20	15,875	107,1	4	402,2	1208,9	280	129
HDL TSB-U 120-20-15-5	1	120	20	15,875	107,1	5	491,1	1541,1	350	149
HDL TSB-U 120-20-15-6	1	120	20	15,875	107,1	6	575,3	1859,9	410	169
HDL TSB-U 120-20-15-7	1	120	20	15,875	107,1	7	657,7	2178,7	470	189
HDL TSB-U 120-20-15-8	1	120	20	15,875	107,1	8	741,3	2510,9	520	209
HDL TSB-B 120-20-15-9	1	120	20	15,875	107,1	9	802,8	2736,7	610	239
HDL TSB-B 120-20-15-10	1	120	20	15,875	107,1	10	886,6	3082,1	670	259
HDL TSB-B 120-20-15-11	1	120	20	15,875	107,1	11	946,5	3308	720	283
HDL TSB-B 120-20-15-12	1	120	20	15,875	107,1	12	1023,3	3626,8	780	303
HDL TSB-B 120-20-15-13	1	120	20	15,875	107,1	13	1099,2	3945,6	840	323
HDL TSB-B 120-20-15-14	1	120	20	15,875	107,1	14	1174,2	4264,5	890	343
HDL TSB-B 120-20-15-15	1	120	20	15,875	107,1	15	1255,8	4623,2	940	361
HDL TSB-B 120-20-15-16	1	120	20	15,875	107,1	16	1310,1	4835,7	980	382
HDL TSB-B 120-20-15-17	1	120	20	15,875	107,1	17	1383,2	5154,6	1000	402
HDL TSB-B 120-20-15-18	1	120	20	15,875	107,1	18	1455,6	5473,4	1050	422
HDL TSB-B 120-20-15-19	1	120	20	15,875	107,1	19	1536,8	5845,4	1100	442

- C_a and C_{oa} : Modified static and dynamic load capacities, calculated according to DIN 69051/4 standard and ISO3408/5. See Technical description catalogue.

- Check with SHUTON-IPIRANGA in case higher loads or more adjusted nut dimensions are required.

- Check external maximum axial force in the two senses.

For the indicated leads, in case C_a and C_{oa} requirements is lower, there is possibility of smaller size balls.

Maximum force (Peak load CO-CO and TR-TR) calculated with the flange/nut clamping in opposite position to the main support of the shaft, with same load type (traction or compression) in both nut and shaft. For same-side clamping, so different type of load, contact SHUTON-IPIRANGA as peak load is lower.

Nut dimensions									Grease quantity TS
$D_{1, std}$	$D_{1, min}$	D_4	D_6	D_5	L_7	L_1	L_8	L_9	$Q_{Gr} [cm^3]$
175	(170)	201 (196)	227 (222)	17,5	40	40	180 (175)	203,5 (198,5)	full=496
175	(170)	201 (196)	227 (222)	17,5	40	40	180 (175)	203,5 (198,5)	full=524
175	(170)	201 (196)	227 (222)	17,5	40	40	180 (175)	203,5 (198,5)	full=552
175	(170)	201 (196)	227 (222)	17,5	40	40	180 (175)	203,5 (198,5)	full=572
170		196	222	17,5	30	25	175	198,5	full=140
170		196	222	17,5	30	25	175	198,5	full=167
170		196	222	17,5	30	25	175	198,5	full=195
170		196	222	17,5	30	25	175	198,5	full=224
170		196	222	17,5	30	25	175	198,5	full=255
175	(170)	201 (196)	227 (222)	17,5	40	40	180 (175)	203,5 (198,5)	full=324
175	(170)	201 (196)	227 (222)	17,5	40	40	180 (175)	203,5 (198,5)	full=349
175	(170)	201 (196)	227 (222)	17,5	40	40	180 (175)	203,5 (198,5)	full=378
175	(170)	201 (196)	227 (222)	17,5	40	40	180 (175)	203,5 (198,5)	full=413
175	(170)	201 (196)	227 (222)	17,5	40	40	180 (175)	203,5 (198,5)	full=444
175	(170)	201 (196)	227 (222)	17,5	40	40	180 (175)	203,5 (198,5)	full=468
175	(170)	201 (196)	227 (222)	17,5	40	40	180 (175)	203,5 (198,5)	full=501
175	(170)	201 (196)	227 (222)	17,5	40	40	180 (175)	203,5 (198,5)	full=532
175	(170)	201 (196)	227 (222)	17,5	40	40	180 (175)	203,5 (198,5)	full=552
180		206	232	17,5	30	40	185	208,5	full=133
180		206	232	17,5	30	40	185	208,5	full=167
180		206	232	17,5	30	40	185	208,5	full=205
180		206	232	17,5	30	40	185	208,5	full=241
180		206	232	17,5	30	40	185	208,5	full=279
180		206	232	17,5	30	40	185	208,5	full=321
180		206	232	17,5	30	40	185	208,5	full=363
185		211	237	17,5	45	40	190	213,5	full=516
185		211	237	17,5	45	40	190	213,5	full=552
185		211	237	17,5	45	40	190	213,5	full=610
185		211	237	17,5	45	40	190	213,5	full=648
185		211	237	17,5	45	40	190	213,5	full=680
185		211	237	17,5	45	40	190	213,5	full=718
185		211	237	17,5	45	40	190	213,5	full=748
185		211	237	17,5	45	40	190	213,5	full=796
185		214	243	20	45	40	190	216,5	full=828
185		214	243	20	45	40	190	216,5	full=868
185		214	243	20	45	40	190	216,5	full=900

SHUTON-IPIRANGA advises to use the dimensions of the tables, although it is possible to manufacture ball screw with other dimensions. In brackets () second options.

Smaller nut diameters than the first option of the table can reduce the rigidity of the assembly between 5 and 10%. Please consult SHUTON-IPIRANGA.

High Load HDL TS Single nut, DN up to 110.000

Ball screw reference	Number of starts	Nominal diameter (mm)	Lead (mm)	Ball Diameter (mm)	Root diameter (mm)	Circuits	Dynamic load capacity	Static load capacity	Peak load CO-CO TR-TR 'TS'	Nut length
	$l/2$	d_0	P_h	D_w	d_2	i	C_a [kN]	C_{oa} [kN]	F_{max} [kN]	$L_{n, std}$ [mm]
HDL TSB-B 120-20-15-20	1	120	20	15,875	107,1	20	1608	6164,2	1150	462
HDL TSB-U 120-25-15-2	1	120	25	15,875	107,1	2	223,2	557,6	130	98
HDL TSB-U 120-25-15-3	1	120	25	15,875	107,1	3	314,1	889,4	210	123
HDL TSB-U 120-25-15-4	1	120	25	15,875	107,1	4	401,8	1208	270	148
HDL TSB-U 120-25-15-5	1	120	25	15,875	107,1	5	490,6	1539,9	340	173
HDL TSB-U 120-25-15-6	1	120	25	15,875	107,1	6	574,7	1858,5	410	198
HDL TSB-U 120-25-15-7	1	120	25	15,875	107,1	7	659,8	2190,4	460	223
HDL TSB-U 120-25-15-8	1	120	25	15,875	107,1	8	740,6	2509	510	248
HDL TSB-B 120-25-15-9	1	120	25	15,875	107,1	9	807,2	2761,2	600	287
HDL TSB-B 120-25-15-10	1	120	25	15,875	107,1	10	885,8	3079,8	650	312
HDL TSB-B 120-25-15-11	1	120	25	15,875	107,1	11	945,6	3305,5	700	341
HDL TSB-B 120-25-15-12	1	120	25	15,875	107,1	12	1022,3	3624,1	740	364
HDL TSB-B 120-25-15-13	1	120	25	15,875	107,1	13	1098,1	3942,7	800	389
HDL TSB-B 120-25-15-14	1	120	25	15,875	107,1	14	1180,4	4301,1	840	414
HDL TSB-B 120-25-15-15	1	120	25	15,875	107,1	15	1254,5	4619,7	880	439
HDL TSB-B 120-25-15-16	1	120	25	15,875	107,1	16	1308,9	4832,1	900	466
HDL TSB-B 120-25-15-17	1	120	25	15,875	107,1	17	1381,8	5150,7	930	485
HDL TSB-U 120-25-19-2	1	120	25	19,05	104,1	2	286,4	665	160	100
HDL TSB-U 120-25-19-3	1	120	25	19,05	104,1	3	406,8	1075,7	250	125
HDL TSB-U 120-25-19-4	1	120	25	19,05	104,1	4	521,8	1466,8	350	150
HDL TSB-U 120-25-19-5	1	120	25	19,05	104,1	5	638,9	1877,5	440	175
HDL TSB-U 120-25-19-6	1	120	25	19,05	104,1	6	749	2268,7	520	200
HDL TSB-U 120-25-19-7	1	120	25	19,05	104,1	7	856,8	2659,8	590	225
HDL TSB-U 120-25-19-8	1	120	25	19,05	104,1	8	966,8	3070,5	660	250
HDL TSB-U 120-25-19-9	1	120	25	19,05	104,1	9	1070,9	3461,7	710	275
HDL TSB-U 120-25-19-10	1	120	25	19,05	104,1	10	1177,4	3872,4	770	300
HDL TSB-B 120-25-19-11	1	120	25	19,05	104,1	11	1254,9	4146,2	890	343
HDL TSB-B 120-25-19-12	1	120	25	19,05	104,1	12	1355	4537,3	940	366
HDL TSB-B 120-25-19-13	1	120	25	19,05	104,1	13	1430,8	4811,1	1000	395
HDL TSB-B 120-25-19-14	1	120	25	19,05	104,1	14	1532,8	5221,9	1050	420
HDL TSB-B 120-25-19-15	1	120	25	19,05	104,1	15	1633,7	5632,6	1100	445
HDL TSB-B 120-25-19-16	1	120	25	19,05	104,1	16	1722,3	5984,6	1150	470
HDL TSB-B 120-25-19-17	1	120	25	19,05	104,1	17	1821,4	6395,3	1150	487
HDL TSB-U 120-30-19-2	1	120	30	19,05	104,1	2	286,1	664,4	160	109
HDL TSB-U 120-30-19-3	1	120	30	19,05	104,1	3	406,3	1074,7	250	139
HDL TSB-U 120-30-19-4	1	120	30	19,05	104,1	4	521,2	1465,5	350	169

- C_a and C_{oa} : Modified static and dynamic load capacities, calculated according to DIN 69051/4 standard and ISO3408/5. See Technical description catalogue.

- Check with SHUTON-IPIRANGA in case higher loads or more adjusted nut dimensions are required.

- Check external maximum axial force in the two senses.

For the indicated leads, in case C_a and C_{oa} requirements is lower, there is possibility of smaller size balls.

Maximum force (Peak load CO-CO and TR-TR) calculated with the flange/nut clamping in opposite position to the main support of the shaft, with same load type (traction or compression) in both nut and shaft. For same-side clamping, so different type of load, contact SHUTON-IPIRANGA as peak load is lower.

Nut dimensions									Grease quantity TS
$D_{1, std}$	$D_{1, min}$	D_4	D_6	D_5	L_7	L_1	L_8	L_9	$Q_{Gr} [cm^3]$
185		214	243	20	45	40	190	216,5	full=940
180		206	232	17,5	30	40	185	208,5	full=135
180		206	232	17,5	30	40	185	208,5	full=175
180		206	232	17,5	30	40	185	208,5	full=219
180		206	232	17,5	30	40	185	208,5	full=262
180		206	232	17,5	30	40	185	208,5	full=306
180		206	232	17,5	30	40	185	208,5	full=352
180		206	232	17,5	30	40	185	208,5	full=403
185		211	237	17,5	45	40	190	213,5	full=555
185		211	237	17,5	45	40	190	213,5	full=601
185		211	237	17,5	45	40	190	213,5	full=664
185		211	237	17,5	45	40	190	213,5	full=701
185		211	237	17,5	45	40	190	213,5	full=739
185		211	237	17,5	45	40	190	213,5	full=778
185		211	237	17,5	45	40	190	213,5	full=828
185		211	237	17,5	45	40	190	213,5	full=886
185		211	237	17,5	45	40	190	213,5	full=903
190		216	242	17,5	40	40	195	218,5	full=360
190		216	242	17,5	40	40	195	218,5	full=410
190		216	242	17,5	40	40	195	218,5	full=460
190		216	242	17,5	40	40	195	218,5	full=514
190		216	242	17,5	40	40	195	218,5	full=571
190		216	242	17,5	40	40	195	218,5	full=632
190		216	242	17,5	40	40	195	218,5	full=693
190		216	242	17,5	40	40	195	218,5	full=762
190		216	242	17,5	40	40	195	218,5	full=833
195	(190)	221 (216)	247 (242)	17,5	50	40	200 (195)	223,5 (218,5)	full=853
195	(190)	221 (216)	247 (242)	17,5	50	40	200 (195)	223,5 (218,5)	full=905
195	(190)	224 (219)	253 (248)	20	50	40	200 (195)	226,5 (221,5)	full=978
195	(190)	224 (219)	253 (248)	20	50	40	200 (195)	226,5 (221,5)	full=1031
195	(190)	224 (219)	253 (248)	20	50	40	200 (195)	226,5 (221,5)	full=1085
195	(190)	224 (219)	253 (248)	20	50	40	200 (195)	226,5 (221,5)	full=1150
195	(190)	224 (219)	253 (248)	20	50	40	200 (195)	226,5 (221,5)	full=1166
190		216	242	17,5	40	40	195	218,5	full=341
190		216	242	17,5	40	40	195	218,5	full=398
190		216	242	17,5	40	40	195	218,5	full=455

SHUTON-IPIRANGA advises to use the dimensions of the tables, although it is possible to manufacture ball screw with other dimensions. In brackets () second options.

Smaller nut diameters than the first option of the table can reduce the rigidity of the assembly between 5 and 10%. Please consult SHUTON-IPIRANGA.

High Load HDL TS Single nut, DN up to 110.000

Ball screw reference	Number of starts	Nominal diameter (mm)	Lead (mm)	Ball Diameter (mm)	Root diameter (mm)	Circuits	Dynamic load capacity	Static load capacity	Peak load CO-CO TR-TR 'TS'	Nut length
	$1/2$	d_0	P_h	D_w	d_2	i	C_a [kN]	C_{oa} [kN]	F_{max} [kN]	$L_{n,std}$ [mm]
HDL TSB-U 120-30-19-5	1	120	30	19,05	104,1	5	638,1	1875,8	430	199
HDL TSB-U 120-30-19-6	1	120	30	19,05	104,1	6	748,1	2266,6	510	229
HDL TSB-U 120-30-19-7	1	120	30	19,05	104,1	7	860	2676,9	580	259
HDL TSB-U 120-30-19-8	1	120	30	19,05	104,1	8	965,7	3067,7	640	289
HDL TSB-B 120-30-19-9	1	120	30	19,05	104,1	9	1041,2	3321,8	720	340
HDL TSB-B 120-30-19-10	1	120	30	19,05	104,1	10	1152,1	3751,6	790	368
HDL TSB-B 120-30-19-11	1	120	30	19,05	104,1	11	1253,4	4142,4	850	398
HDL TSB-B 120-30-19-12	1	120	30	19,05	104,1	12	1353,4	4533,2	890	428
HDL TSB-B 120-30-19-13	1	120	30	19,05	104,1	13	1429,1	4806,8	940	463
HDL TSB-B 120-30-19-14	1	120	30	19,05	104,1	14	1531	5217,1	970	483
HDL TSB-B 120-30-25-2	1	120	30	25,4	98,7	2	416,6	866,4	180	126
HDL TSB-B 120-30-25-3	1	120	30	25,4	98,7	3	603,6	1444,1	300	156
HDL TSB-B 120-30-25-4	1	120	30	25,4	98,7	4	778,5	1985,6	410	186
HDL TSB-B 120-30-25-5	1	120	30	25,4	98,7	5	958,6	2563,2	520	216
HDL TSB-B 120-30-25-6	1	120	30	25,4	98,7	6	1125,6	3104,7	620	246
HDL TSB-B 120-30-25-7	1	120	30	25,4	98,7	7	1246,3	3465,7	700	291
HDL TSB-B 120-30-25-8	1	120	30	25,4	98,7	8	1399,3	3971,1	780	321
HDL TSB-B 120-30-25-9	1	120	30	25,4	98,7	9	1566,4	4548,8	870	351
HDL TSB-B 120-30-25-10	1	120	30	25,4	98,7	10	1730,7	5126,4	950	379
HDL TSB-B 120-30-25-11	1	120	30	25,4	98,7	11	1876,5	5631,8	1000	409
HDL TSB-B 120-30-25-12	1	120	30	25,4	98,7	12	2036,4	6209,4	1100	439
HDL TSB-B 120-30-25-13	1	120	30	25,4	98,7	13	2131,5	6498,2	1100	474
HDL TSB(2S)-U 120-32-12-2	2	120	32	12,7	110	2	254,2	750,8	160	117
HDL TSB(2S)-U 120-32-12-3	2	120	32	12,7	110	3	350,1	1160,3	250	149
HDL TSB(2S)-U 120-32-12-4	2	120	32	12,7	110	4	449,3	1583,5	330	181
HDL TSB(2S)-U 120-32-12-5	2	120	32	12,7	110	5	544	1993	410	213
HDL TSB(2S)-U 120-32-12-6	2	120	32	12,7	110	6	639,2	2416,2	490	245
HDL TSB(2S)-B 120-32-12-7	2	120	32	12,7	110	7	701,5	2661,9	550	291
HDL TSB(2S)-B 120-32-12-8	2	120	32	12,7	110	8	791,3	3071,4	630	323
HDL TSB(2S)-B 120-32-12-9	2	120	32	12,7	110	9	879,5	3480,9	680	355
HDL TSB(2S)-B 120-32-12-10	2	120	32	12,7	110	10	955,1	3822,2	740	387
HDL TSB(2S)-B 120-32-12-11	2	120	32	12,7	110	11	1036,4	4204,4	780	419
HDL TSB(2S)-B 120-32-12-12	2	120	32	12,7	110	12	1125,6	4641,2	840	451
HDL TSB(2S)-B 120-32-12-13	2	120	32	12,7	110	13	1198,4	4982,5	870	485
HDL TSB(2S)-B 120-32-12-14	2	120	32	12,7	110	14	1281,3	5392	900	517
HDL TSB(2S)-B 120-32-12-15	2	120	32	12,7	110	15	1363,4	5801,6	920	539

- C_a and C_{oa} : Modified static and dynamic load capacities, calculated according to DIN 69051/4 standard and ISO3408/5. See Technical description catalogue.

- Check with SHUTON-IPIRANGA in case higher loads or more adjusted nut dimensions are required.

- Check external maximum axial force in the two senses.

For the indicated leads, in case C_a and C_{oa} requirements is lower, there is possibility of smaller size balls.

Maximum force (Peak load CO-CO and TR-TR) calculated with the flange/nut clamping in opposite position to the main support of the shaft, with same load type (traction or compression) in both nut and shaft. For same-side clamping, so different type of load, contact SHUTON-IPIRANGA as peak load is lower.

Nut dimensions									Grease quantity TS
$D_{1, std}$	$D_{1, min}$	D_4	D_6	D_5	L_7	L_1	L_8	L_9	$Q_{Gr} [cm^3]$
190		216	242	17,5	40	40	195	218,5	full=516
190		216	242	17,5	40	40	195	218,5	full=580
190		216	242	17,5	40	40	195	218,5	full=644
190		216	242	17,5	40	40	195	218,5	full=716
195	(190)	221 (216)	247 (242)	17,5	50	40	200 (195)	223,5 (218,5)	full=794
195	(190)	221 (216)	247 (242)	17,5	50	40	200 (195)	223,5 (218,5)	full=839
195	(190)	221 (216)	247 (242)	17,5	50	40	200 (195)	223,5 (218,5)	full=899
195	(190)	221 (216)	247 (242)	17,5	50	40	200 (195)	223,5 (218,5)	full=967
195	(190)	221 (216)	247 (242)	17,5	50	40	200 (195)	223,5 (218,5)	full=1049
195	(190)	221 (216)	247 (242)	17,5	50	40	200 (195)	223,5 (218,5)	full=1068
210		243	275	22	60	40	215	245	full=569
210		243	275	22	60	40	215	245	full=647
210		243	275	22	60	40	215	245	full=734
210		243	275	22	60	40	215	245	full=821
210		243	275	22	60	40	215	245	full=916
210		243	275	22	60	40	215	245	full=1123
210		243	275	22	60	40	215	245	full=1227
210		243	275	22	60	40	215	245	full=1314
210		243	275	22	60	40	215	245	full=1387
210		243	275	22	60	40	215	245	full=1491
210		243	275	22	60	40	215	245	full=1577
210		243	275	22	60	40	215	245	full=1741
170		196	222	17,5	30	25	175	198,5	full=183
170		196	222	17,5	30	25	175	198,5	full=229
170		196	222	17,5	30	25	175	198,5	full=274
170		196	222	17,5	30	25	175	198,5	full=325
170		196	222	17,5	30	25	175	198,5	full=375
175	(170)	201 (196)	227 (222)	17,5	40	40	180 (175)	203,5 (198,5)	full=511
175	(170)	201 (196)	227 (222)	17,5	40	40	180 (175)	203,5 (198,5)	full=552
175	(170)	201 (196)	227 (222)	17,5	40	40	180 (175)	203,5 (198,5)	full=601
175	(170)	201 (196)	227 (222)	17,5	40	40	180 (175)	203,5 (198,5)	full=655
175	(170)	201 (196)	227 (222)	17,5	40	40	180 (175)	203,5 (198,5)	full=709
175	(170)	201 (196)	227 (222)	17,5	40	40	180 (175)	203,5 (198,5)	full=747
175	(170)	201 (196)	227 (222)	17,5	40	40	180 (175)	203,5 (198,5)	full=806
175	(170)	201 (196)	227 (222)	17,5	40	40	180 (175)	203,5 (198,5)	full=858
175	(170)	201 (196)	227 (222)	17,5	40	40	180 (175)	203,5 (198,5)	full=867

SHUTON-IPIRANGA advises to use the dimensions of the tables, although it is possible to manufacture ball screw with other dimensions. In brackets () second options.

Smaller nut diameters than the first option of the table can reduce the rigidity of the assembly between 5 and 10%. Please consult SHUTON-IPIRANGA.

High Load HDL TS Single nut, DN up to 110.000

Ball screw reference	Number of starts	Nominal diameter (mm)	Lead (mm)	Ball Diameter (mm)	Root diameter (mm)	Circuits	Dynamic load capacity	Static load capacity	Peak load CO-CO TR-TR 'TS'	Nut length
	$l/2$	d_0	P_h	D_w	d_2	i	C_a [kN]	C_{oa} [kN]	F_{max} [kN]	$L_{n,std}$ [mm]
HDL TSB-B 120-32-25-2	1	120	32	25,4	98,7	2	416,4	866,1	180	130
HDL TSB-B 120-32-25-3	1	120	32	25,4	98,7	3	603,2	1443,5	300	162
HDL TSB-B 120-32-25-4	1	120	32	25,4	98,7	4	778,1	1984,8	410	194
HDL TSB-B 120-32-25-5	1	120	32	25,4	98,7	5	958,1	2562,2	520	226
HDL TSB-B 120-32-25-6	1	120	32	25,4	98,7	6	1125	3103,5	610	258
HDL TSB-B 120-32-25-7	1	120	32	25,4	98,7	7	1245,6	3464,3	700	306
HDL TSB-B 120-32-25-8	1	120	32	25,4	98,7	8	1398,5	3969,5	770	338
HDL TSB-B 120-32-25-9	1	120	32	25,4	98,7	9	1565,6	4546,9	860	361
HDL TSB-B 120-32-25-10	1	120	32	25,4	98,7	10	1729,8	5124,3	930	400
HDL TSB-B 120-32-25-11	1	120	32	25,4	98,7	11	1875,5	5629,5	990	432
HDL TSB-B 120-32-25-12	1	120	32	25,4	98,7	12	2035,3	6206,9	1050	464
HDL TSB(2S)-U 120-40-12-2	2	120	40	12,7	110	2	253,5	749,4	160	128
HDL TSB(2S)-U 120-40-12-3	2	120	40	12,7	110	3	349,2	1158,1	250	168
HDL TSB(2S)-U 120-40-12-4	2	120	40	12,7	110	4	448,2	1580,5	330	208
HDL TSB(2S)-U 120-40-12-5	2	120	40	12,7	110	5	542,7	1989,2	400	248
HDL TSB(2S)-B 120-40-12-6	2	120	40	12,7	110	6	620,6	2316,2	470	303
HDL TSB(2S)-B 120-40-12-7	2	120	40	12,7	110	7	699,7	2656,8	530	350
HDL TSB(2S)-B 120-40-12-8	2	120	40	12,7	110	8	789,3	3065,5	590	371
HDL TSB(2S)-B 120-40-12-9	2	120	40	12,7	110	9	877,3	3474,3	640	428
HDL TSB(2S)-B 120-40-12-10	2	120	40	12,7	110	10	952,7	3814,9	670	471
HDL TSB(2S)-B 120-40-12-11	2	120	40	12,7	110	11	1042,8	4250,9	710	511
HDL TSB(2S)-B 120-40-12-12	2	120	40	12,7	110	12	1122,8	4632,4	730	536
HDL TSB(2S)-U 120-40-15-2	2	120	40	15,875	107,1	2	350,4	948,3	220	135
HDL TSB(2S)-U 120-40-15-3	2	120	40	15,875	107,1	3	485,3	1477,6	340	175
HDL TSB(2S)-U 120-40-15-4	2	120	40	15,875	107,1	4	625,4	2028,9	450	215
HDL TSB(2S)-U 120-40-15-5	2	120	40	15,875	107,1	5	758,1	2558,2	560	255
HDL TSB(2S)-U 120-40-15-6	2	120	40	15,875	107,1	6	892,2	3109,6	660	295
HDL TSB(2S)-B 120-40-15-7	2	120	40	15,875	107,1	7	990,4	3484,5	730	351
HDL TSB(2S)-B 120-40-15-8	2	120	40	15,875	107,1	8	1124,1	4057,9	820	389
HDL TSB(2S)-B 120-40-15-9	2	120	40	15,875	107,1	9	1247,3	4587,2	890	429
HDL TSB(2S)-B 120-40-15-10	2	120	40	15,875	107,1	10	1368,6	5116,5	940	469
HDL TSB(2S)-B 120-40-15-11	2	120	40	15,875	107,1	11	1461,1	5491,4	970	503
HDL TSB(2S)-B 120-40-15-12	2	120	40	15,875	107,1	12	1591,2	6086,8	1000	543
HDL TSB(2S)-U 120-50-15-2	2	120	50	15,875	107,1	2	349	945,5	220	149
HDL TSB(2S)-U 120-50-15-3	2	120	50	15,875	107,1	3	483,4	1473,2	340	199
HDL TSB(2S)-U 120-50-15-4	2	120	50	15,875	107,1	4	623	2022,9	440	249

- C_a and C_{oa} : Modified static and dynamic load capacities, calculated according to DIN 69051/4 standard and ISO3408/5. See Technical description catalogue.

- Check with SHUTON-IPIRANGA in case higher loads or more adjusted nut dimensions are required.

- Check external maximum axial force in the two senses.

For the indicated leads, in case C_a and C_{oa} requirements is lower, there is possibility of smaller size balls.

Maximum force (Peak load CO-CO and TR-TR) calculated with the flange/nut clamping in opposite position to the main support of the shaft, with same load type (traction or compression) in both nut and shaft. For same-side clamping, so different type of load, contact SHUTON-IPIRANGA as peak load is lower.

Nut dimensions									Grease quantity TS
$D_{1, std}$	$D_{1, min}$	D_4	D_6	D_5	L_7	L_1	L_8	L_9	$Q_{Gr} [cm^3]$
210		243	275	22	60	40	215	245	full=560
210		243	275	22	60	40	215	245	full=642
210		243	275	22	60	40	215	245	full=732
210		243	275	22	60	40	215	245	full=823
210		243	275	22	60	40	215	245	full=922
210		243	275	22	60	40	215	245	full=1134
210		243	275	22	60	40	215	245	full=1242
210		243	275	22	60	40	215	245	full=1273
210		243	275	22	60	40	215	245	full=1409
210		243	275	22	60	40	215	245	full=1517
210		243	275	22	60	40	215	245	full=1607
170		196	222	17,5	30	25	175	198,5	full=188
170		196	222	17,5	30	25	175	198,5	full=243
170		196	222	17,5	30	25	175	198,5	full=298
170		196	222	17,5	30	25	175	198,5	full=358
175	(170)	201 (196)	227 (222)	17,5	40	40	180 (175)	203,5 (198,5)	full=484
175	(170)	201 (196)	227 (222)	17,5	40	40	180 (175)	203,5 (198,5)	full=570
175	(170)	201 (196)	227 (222)	17,5	40	40	180 (175)	203,5 (198,5)	full=566
175	(170)	201 (196)	227 (222)	17,5	40	40	180 (175)	203,5 (198,5)	full=673
175	(170)	201 (196)	227 (222)	17,5	40	40	180 (175)	203,5 (198,5)	full=745
175	(170)	201 (196)	227 (222)	17,5	40	40	180 (175)	203,5 (198,5)	full=801
175	(170)	201 (196)	227 (222)	17,5	40	40	180 (175)	203,5 (198,5)	full=813
180		206	232	17,5	30	40	185	208,5	full=194
180		206	232	17,5	30	40	185	208,5	full=266
180		206	232	17,5	30	40	185	208,5	full=338
180		206	232	17,5	30	40	185	208,5	full=415
180		206	232	17,5	30	40	185	208,5	full=487
185		211	237	17,5	45	40	190	213,5	full=749
185		211	237	17,5	45	40	190	213,5	full=813
185		211	237	17,5	45	40	190	213,5	full=885
185		211	237	17,5	45	40	190	213,5	full=966
185		211	237	17,5	45	40	190	213,5	full=1026
185		214	243	20	45	40	190	216,5	full=1090
180		206	232	17,5	30	40	185	208,5	full=207
180		206	232	17,5	30	40	185	208,5	full=293
180		206	232	17,5	30	40	185	208,5	full=378

SHUTON-IPIRANGA advises to use the dimensions of the tables, although it is possible to manufacture ball screw with other dimensions. In brackets () second options.

Smaller nut diameters than the first option of the table can reduce the rigidity of the assembly between 5 and 10%. Please consult SHUTON-IPIRANGA.

High Load HDL TS Single nut, DN up to 110.000

Ball screw reference	Number of starts	Nominal diameter (mm)	Lead (mm)	Ball Diameter (mm)	Root diameter (mm)	Circuits	Dynamic load capacity	Static load capacity	Peak load CO-CO TR-TR 'TS'	Nut length
	$l/2$	d_0	P_h	D_w	d_2	i	C_a [kN]	C_{oa} [kN]	F_{max} [kN]	$L_{n,std}$ [mm]
HDL TSB(2S)-U 120-50-15-5	2	120	50	15,875	107,1	5	755,2	2550,7	540	299
HDL TSB(2S)-B 120-50-15-6	2	120	50	15,875	107,1	6	859,1	2946,5	620	372
HDL TSB(2S)-B 120-50-15-7	2	120	50	15,875	107,1	7	994,9	3518,2	700	422
HDL TSB(2S)-B 120-50-15-8	2	120	50	15,875	107,1	8	1119,7	4045,9	750	472
HDL TSB(2S)-B 120-50-15-9	2	120	50	15,875	107,1	9	1214,5	4419,7	780	514
HDL TSB(2S)-U 120-50-19-2	2	120	50	19,05	104,1	2	449,5	1133,8	270	155
HDL TSB(2S)-U 120-50-19-3	2	120	50	19,05	104,1	3	626,2	1781,8	410	205
HDL TSB(2S)-U 120-50-19-4	2	120	50	19,05	104,1	4	810,3	2462,1	550	255
HDL TSB(2S)-U 120-50-19-5	2	120	50	19,05	104,1	5	983,4	3110	680	305
HDL TSB(2S)-B 120-50-19-6	2	120	50	19,05	104,1	6	1112,8	3563,5	760	380
HDL TSB(2S)-B 120-50-19-7	2	120	50	19,05	104,1	7	1279,8	4211,4	860	430
HDL TSB(2S)-B 120-50-19-8	2	120	50	19,05	104,1	8	1456,4	4924,1	950	480
HDL TSB(2S)-B 120-50-19-9	2	120	50	19,05	104,1	9	1573	5345,3	970	522
HDL TSB-U 140-16-12-2	1	140	16	12,7	130	2	175	528,4	110	79
HDL TSB-U 140-16-12-3	1	140	16	12,7	130	3	242,8	825,6	180	95
HDL TSB-U 140-16-12-4	1	140	16	12,7	130	4	309,4	1114,6	240	111
HDL TSB-U 140-16-12-5	1	140	16	12,7	130	5	374,8	1403,6	300	127
HDL TSB-U 140-16-12-6	1	140	16	12,7	130	6	440,2	1700,8	360	143
HDL TSB-B 140-16-12-7	1	140	16	12,7	130	7	484,6	1882,5	410	166
HDL TSB-B 140-16-12-8	1	140	16	12,7	130	8	547,9	2179,7	470	182
HDL TSB-B 140-16-12-9	1	140	16	12,7	130	9	610,1	2476,9	530	198
HDL TSB-B 140-16-12-10	1	140	16	12,7	130	10	660,6	2708,1	580	215
HDL TSB-B 140-16-12-11	1	140	16	12,7	130	11	721,1	3005,3	640	231
HDL TSB-B 140-16-12-12	1	140	16	12,7	130	12	780,8	3302,5	690	247
HDL TSB-B 140-16-12-13	1	140	16	12,7	130	13	832	3550,2	740	264
HDL TSB-B 140-16-12-14	1	140	16	12,7	130	14	889,2	3839,2	780	280
HDL TSB-B 140-16-12-15	1	140	16	12,7	130	15	945,7	4128,2	840	296
HDL TSB-U 140-20-12-2	1	140	20	12,7	130	2	174,9	528,2	110	87
HDL TSB-U 140-20-12-3	1	140	20	12,7	130	3	242,7	825,3	180	107
HDL TSB-U 140-20-12-4	1	140	20	12,7	130	4	309,3	1114,2	240	127
HDL TSB-U 140-20-12-5	1	140	20	12,7	130	5	376,1	1411,3	300	147
HDL TSB-B 140-20-12-6	1	140	20	12,7	130	6	431,4	1650,7	350	173
HDL TSB-B 140-20-12-7	1	140	20	12,7	130	7	484,4	1881,8	410	197
HDL TSB-B 140-20-12-8	1	140	20	12,7	130	8	547,6	2178,9	470	217
HDL TSB-B 140-20-12-9	1	140	20	12,7	130	9	609,8	2476	520	237
HDL TSB-B 140-20-12-10	1	140	20	12,7	130	10	660,3	2707,1	570	258

- C_a and C_{oa} : Modified static and dynamic load capacities, calculated according to DIN 69051/4 standard and ISO3408/5. See Technical description catalogue.

- Check with SHUTON-IPIRANGA in case higher loads or more adjusted nut dimensions are required.

- Check external maximum axial force in the two senses.

For the indicated leads, in case C_a and C_{oa} requirements is lower, there is possibility of smaller size balls.

Maximum force (Peak load CO-CO and TR-TR) calculated with the flange/nut clamping in opposite position to the main support of the shaft, with same load type (traction or compression) in both nut and shaft. For same-side clamping, so different type of load, contact SHUTON-IPIRANGA as peak load is lower.

Nut dimensions									Grease quantity TS
$D_{1, std}$	$D_{1, min}$	D_4	D_6	D_5	L_7	L_1	L_8	L_9	$Q_{Gr} [cm^3]$
180		206	232	17,5	30	40	185	208,5	full=467
185		211	237	17,5	45	40	190	213,5	full=735
185		211	237	17,5	45	40	190	213,5	full=812
185		211	237	17,5	45	40	190	213,5	full=905
185		211	237	17,5	45	40	190	213,5	full=975
190		216	242	17,5	40	40	195	218,5	full=454
190		216	242	17,5	40	40	195	218,5	full=562
190		216	242	17,5	40	40	195	218,5	full=656
190		216	242	17,5	40	40	195	218,5	full=772
195	(190)	221 (216)	247 (242)	17,5	50	40	200 (195)	223,5 (218,5)	full=991
195	(190)	221 (216)	247 (242)	17,5	50	40	200 (195)	223,5 (218,5)	full=1085
195	(190)	221 (216)	247 (242)	17,5	50	40	200 (195)	223,5 (218,5)	full=1180
195	(190)	221 (216)	247 (242)	17,5	50	40	200 (195)	223,5 (218,5)	full=1301
190		216	242	17,5	30	40	195	218,5	full=116
190		216	242	17,5	30	40	195	218,5	full=141
190		216	242	17,5	30	40	195	218,5	full=169
190		216	242	17,5	30	40	195	218,5	full=197
190		216	242	17,5	30	40	195	218,5	full=225
195	(190)	221 (216)	247 (242)	17,5	40	40	200 (195)	223,5 (218,5)	full=344
195	(190)	221 (216)	247 (242)	17,5	40	40	200 (195)	223,5 (218,5)	full=370
195	(190)	221 (216)	247 (242)	17,5	40	40	200 (195)	223,5 (218,5)	full=396
195	(190)	221 (216)	247 (242)	17,5	40	40	200 (195)	223,5 (218,5)	full=434
195	(190)	221 (216)	247 (242)	17,5	40	40	200 (195)	223,5 (218,5)	full=457
195	(190)	221 (216)	247 (242)	17,5	40	40	200 (195)	223,5 (218,5)	full=484
195	(190)	221 (216)	247 (242)	17,5	40	40	200 (195)	223,5 (218,5)	full=518
195	(190)	221 (216)	247 (242)	17,5	40	40	200 (195)	223,5 (218,5)	full=547
195	(190)	221 (216)	247 (242)	17,5	40	40	200 (195)	223,5 (218,5)	full=571
190		216	242	17,5	30	40	195	218,5	full=119
190		216	242	17,5	30	40	195	218,5	full=150
190		216	242	17,5	30	40	195	218,5	full=183
190		216	242	17,5	30	40	195	218,5	full=216
195	(190)	221 (216)	247 (242)	17,5	40	40	200 (195)	223,5 (218,5)	full=323
195	(190)	221 (216)	247 (242)	17,5	40	40	200 (195)	223,5 (218,5)	full=373
195	(190)	221 (216)	247 (242)	17,5	40	40	200 (195)	223,5 (218,5)	full=405
195	(190)	221 (216)	247 (242)	17,5	40	40	200 (195)	223,5 (218,5)	full=436
195	(190)	221 (216)	247 (242)	17,5	40	40	200 (195)	223,5 (218,5)	full=478

SHUTON-IPIRANGA advises to use the dimensions of the tables, although it is possible to manufacture ball screw with other dimensions. In brackets () second options.

Smaller nut diameters than the first option of the table can reduce the rigidity of the assembly between 5 and 10%. Please consult SHUTON-IPIRANGA.

High Load HDL TS Single nut, DN up to 110.000

Ball screw reference	Number of starts	Nominal diameter (mm)	Lead (mm)	Ball Diameter (mm)	Root diameter (mm)	Circuits	Dynamic load capacity	Static load capacity	Peak load CO-CO TR-TR 'TS'	Nut length
	$l/2$	d_0	P_h	D_w	d_2	i	C_a [kN]	C_{oa} [kN]	F_{max} [kN]	$L_{n, std}$ [mm]
HDL TSB-B 140-20-12-11	1	140	20	12,7	130	11	720,8	3004,2	620	278
HDL TSB-B 140-20-12-12	1	140	20	12,7	130	12	780,4	3301,4	670	298
HDL TSB-B 140-20-12-13	1	140	20	12,7	130	13	831,6	3549	720	319
HDL TSB-B 140-20-12-14	1	140	20	12,7	130	14	888,8	3837,8	760	339
HDL TSB-B 140-20-12-15	1	140	20	12,7	130	15	945,3	4126,7	800	357
HDL TSB-U 140-20-15-2	1	140	20	15,875	127,1	2	242,4	668,8	160	90
HDL TSB-U 140-20-15-3	1	140	20	15,875	127,1	3	338,9	1056,8	240	110
HDL TSB-U 140-20-15-4	1	140	20	15,875	127,1	4	432,8	1431,3	330	130
HDL TSB-U 140-20-15-5	1	140	20	15,875	127,1	5	524,9	1805,9	410	150
HDL TSB-U 140-20-15-6	1	140	20	15,875	127,1	6	617,5	2193,8	480	170
HDL TSB-U 140-20-15-7	1	140	20	15,875	127,1	7	705,8	2568,4	560	190
HDL TSB-B 140-20-15-8	1	140	20	15,875	127,1	8	777,9	2862,7	630	219
HDL TSB-B 140-20-15-9	1	140	20	15,875	127,1	9	851,5	3170,3	710	243
HDL TSB-B 140-20-15-10	1	140	20	15,875	127,1	10	933,5	3531,5	780	263
HDL TSB-B 140-20-15-11	1	140	20	15,875	127,1	11	1021,4	3932,8	850	283
HDL TSB-B 140-20-15-12	1	140	20	15,875	127,1	12	1101,2	4294	920	303
HDL TSB-B 140-20-15-13	1	140	20	15,875	127,1	13	1171,1	4601,7	980	324
HDL TSB-B 140-20-15-14	1	140	20	15,875	127,1	14	1251,5	4976,2	1050	344
HDL TSB-B 140-20-15-15	1	140	20	15,875	127,1	15	1331	5350,8	1100	362
HDL TSB-B 140-20-15-16	1	140	20	15,875	127,1	16	1409,9	5725,3	1150	382
HDL TSB-B 140-20-15-17	1	140	20	15,875	127,1	17	1474,9	6019,6	1200	403
HDL TSB-B 140-20-15-18	1	140	20	15,875	127,1	18	1556,8	6420,9	1250	423
HDL TSB-B 140-20-15-19	1	140	20	15,875	127,1	19	1627,3	6755,3	1300	443
HDL TSB-B 140-20-15-20	1	140	20	15,875	127,1	20	1707,9	7156,6	1350	463
HDL TSB-U 140-25-15-2	1	140	25	15,875	127,1	2	242,3	668,5	150	99
HDL TSB-U 140-25-15-3	1	140	25	15,875	127,1	3	338,7	1056,2	240	124
HDL TSB-U 140-25-15-4	1	140	25	15,875	127,1	4	432,5	1430,5	320	149
HDL TSB-U 140-25-15-5	1	140	25	15,875	127,1	5	524,5	1804,9	400	174
HDL TSB-U 140-25-15-6	1	140	25	15,875	127,1	6	617,1	2192,6	480	199
HDL TSB-U 140-25-15-7	1	140	25	15,875	127,1	7	705,2	2566,9	550	224
HDL TSB-B 140-25-15-8	1	140	25	15,875	127,1	8	777,4	2861,1	620	262
HDL TSB-B 140-25-15-9	1	140	25	15,875	127,1	9	850,9	3168,6	700	291
HDL TSB-B 140-25-15-10	1	140	25	15,875	127,1	10	932,8	3529,5	750	316
HDL TSB-B 140-25-15-11	1	140	25	15,875	127,1	11	1020,7	3930,6	820	341
HDL TSB-B 140-25-15-12	1	140	25	15,875	127,1	12	1100,4	4291,6	880	364
HDL TSB-B 140-25-15-13	1	140	25	15,875	127,1	13	1170,2	4599,1	930	391

- C_a and C_{oa} : Modified static and dynamic load capacities, calculated according to DIN 69051/4 standard and ISO3408/5. See Technical description catalogue.

- Check with SHUTON-IPIRANGA in case higher loads or more adjusted nut dimensions are required.

- Check external maximum axial force in the two senses.

For the indicated leads, in case C_a and C_{oa} requirements is lower, there is possibility of smaller size balls.

Maximum force (Peak load CO-CO and TR-TR) calculated with the flange/nut clamping in opposite position to the main support of the shaft, with same load type (traction or compression) in both nut and shaft. For same-side clamping, so different type of load, contact SHUTON-IPIRANGA as peak load is lower.

Nut dimensions									Grease quantity TS
$D_{1, std}$	$D_{1, min}$	D_4	D_6	D_5	L_7	L_1	L_8	L_9	$Q_{Gr} [cm^3]$
195	(190)	221 (216)	247 (242)	17,5	40	40	200 (195)	223,5 (218,5)	full=507
195	(190)	221 (216)	247 (242)	17,5	40	40	200 (195)	223,5 (218,5)	full=539
195	(190)	221 (216)	247 (242)	17,5	40	40	200 (195)	223,5 (218,5)	full=578
195	(190)	221 (216)	247 (242)	17,5	40	40	200 (195)	223,5 (218,5)	full=613
195	(190)	221 (216)	247 (242)	17,5	40	40	200 (195)	223,5 (218,5)	full=636
200		226	252	17,5	30	40	205	228,5	full=158
200		226	252	17,5	30	40	205	228,5	full=197
200		226	252	17,5	30	40	205	228,5	full=240
200		226	252	17,5	30	40	205	228,5	full=283
200		226	252	17,5	30	40	205	228,5	full=326
200		226	252	17,5	30	40	205	228,5	full=375
210	(205)	236 (231)	262 (257)	17,5	45	40	215 (210)	238,5 (233,5)	full=552
210	(205)	236 (231)	262 (257)	17,5	45	40	215 (210)	238,5 (233,5)	full=616
210	(205)	236 (231)	262 (257)	17,5	45	40	215 (210)	238,5 (233,5)	full=661
210	(205)	236 (231)	262 (257)	17,5	45	40	215 (210)	238,5 (233,5)	full=700
210	(205)	236 (231)	262 (257)	17,5	45	40	215 (210)	238,5 (233,5)	full=745
210	(205)	236 (231)	262 (257)	17,5	45	40	215 (210)	238,5 (233,5)	full=797
210	(205)	239 (234)	268 (263)	20	45	40	215 (210)	241,5 (236,5)	full=833
210	(205)	239 (234)	268 (263)	20	45	40	215 (210)	241,5 (236,5)	full=869
210	(205)	239 (234)	268 (263)	20	45	40	215 (210)	241,5 (236,5)	full=914
210	(205)	242 (237)	274 (269)	22	45	40	215 (210)	244,5 (239,5)	full=964
210	(205)	242 (237)	274 (269)	22	45	40	215 (210)	244,5 (239,5)	full=996
210	(205)	242 (237)	274 (269)	22	45	40	215 (210)	244,5 (239,5)	full=1050
210	(205)	242 (237)	274 (269)	22	45	40	215 (210)	244,5 (239,5)	full=1092
200		226	252	17,5	30	40	205	228,5	full=160
200		226	252	17,5	30	40	205	228,5	full=206
200		226	252	17,5	30	40	205	228,5	full=256
200		226	252	17,5	30	40	205	228,5	full=306
200		226	252	17,5	30	40	205	228,5	full=357
200		226	252	17,5	30	40	205	228,5	full=413
210	(205)	236 (231)	262 (257)	17,5	45	40	215 (210)	238,5 (233,5)	full=595
210	(205)	236 (231)	262 (257)	17,5	45	40	215 (210)	238,5 (233,5)	full=664
210	(205)	236 (231)	262 (257)	17,5	45	40	215 (210)	238,5 (233,5)	full=716
210	(205)	236 (231)	262 (257)	17,5	45	40	215 (210)	238,5 (233,5)	full=762
210	(205)	236 (231)	262 (257)	17,5	45	40	215 (210)	238,5 (233,5)	full=806
210	(205)	236 (231)	262 (257)	17,5	45	40	215 (210)	238,5 (233,5)	full=869

SHUTON-IPIRANGA advises to use the dimensions of the tables, although it is possible to manufacture ball screw with other dimensions. In brackets () second options.

Smaller nut diameters than the first option of the table can reduce the rigidity of the assembly between 5 and 10%. Please consult SHUTON-IPIRANGA.

High Load HDL TS Single nut, DN up to 110.000

Ball screw reference	Number of starts	Nominal diameter (mm)	Lead (mm)	Ball Diameter (mm)	Root diameter (mm)	Circuits	Dynamic load capacity	Static load capacity	Peak load CO-CO TR-TR 'TS'	Nut length
	$l/2$	d_0	P_h	D_w	d_2	i	C_a [kN]	C_{oa} [kN]	F_{max} [kN]	L_{nstd} [mm]
HDL TSB-B 140-25-15-14	1	140	25	15,875	127,1	14	1250,6	4973,4	990	416
HDL TSB-B 140-25-15-15	1	140	25	15,875	127,1	15	1330,1	5347,8	1050	441
HDL TSB-B 140-25-15-16	1	140	25	15,875	127,1	16	1408,9	5722,1	1050	466
HDL TSB-U 140-25-19-2	1	140	25	19,05	124,1	2	314,8	808,6	190	101
HDL TSB-U 140-25-19-3	1	140	25	19,05	124,1	3	441,1	1282	300	126
HDL TSB-U 140-25-19-4	1	140	25	19,05	124,1	4	563	1735,6	410	151
HDL TSB-U 140-25-19-5	1	140	25	19,05	124,1	5	686,8	2209	510	176
HDL TSB-U 140-25-19-6	1	140	25	19,05	124,1	6	807,8	2682,3	610	201
HDL TSB-U 140-25-19-7	1	140	25	19,05	124,1	7	922,4	3135,9	680	226
HDL TSB-U 140-25-19-8	1	140	25	19,05	124,1	8	1038,7	3609,3	770	251
HDL TSB-B 140-25-19-9	1	140	25	19,05	124,1	9	1126,9	3944,6	870	293
HDL TSB-B 140-25-19-10	1	140	25	19,05	124,1	10	1239,9	4417,9	960	318
HDL TSB-B 140-25-19-11	1	140	25	19,05	124,1	11	1322,2	4733,5	1000	347
HDL TSB-B 140-25-19-12	1	140	25	19,05	124,1	12	1432,6	5206,9	1100	362
HDL TSB-B 140-25-19-13	1	140	25	19,05	124,1	13	1541,6	5680,2	1200	395
HDL TSB-B 140-25-19-14	1	140	25	19,05	124,1	14	1649,5	6153,6	1250	420
HDL TSB-B 140-25-19-15	1	140	25	19,05	124,1	15	1756,2	6626,9	1300	445
HDL TSB-B 140-25-19-16	1	140	25	19,05	124,1	16	1834,1	6942,5	1350	472
HDL TSB-U 140-30-19-2	1	140	30	19,05	124,1	2	314,5	808,1	190	110
HDL TSB-U 140-30-19-3	1	140	30	19,05	124,1	3	440,7	1281,1	300	140
HDL TSB-U 140-30-19-4	1	140	30	19,05	124,1	4	562,5	1734,4	410	170
HDL TSB-U 140-30-19-5	1	140	30	19,05	124,1	5	686,2	2207,5	510	200
HDL TSB-U 140-30-19-6	1	140	30	19,05	124,1	6	807,1	2680,5	600	230
HDL TSB-U 140-30-19-7	1	140	30	19,05	124,1	7	925,4	3153,5	680	260
HDL TSB-U 140-30-19-8	1	140	30	19,05	124,1	8	1037,8	3606,9	750	290
HDL TSB-B 140-30-19-9	1	140	30	19,05	124,1	9	1125,9	3941,9	850	340
HDL TSB-B 140-30-19-10	1	140	30	19,05	124,1	10	1238,9	4415	930	368
HDL TSB-B 140-30-19-11	1	140	30	19,05	124,1	11	1321	4730,3	970	403
HDL TSB-B 140-30-19-12	1	140	30	19,05	124,1	12	1431,3	5203,3	1050	433
HDL TSB-B 140-30-19-13	1	140	30	19,05	124,1	13	1540,3	5676,4	1100	463
HDL TSB-B 140-30-19-14	1	140	30	19,05	124,1	14	1648	6149,4	1150	483
HDL TSB-B 140-30-25-2	1	140	30	25,4	118,7	2	462,7	1058,9	220	126
HDL TSB-B 140-30-25-3	1	140	30	25,4	118,7	3	657,9	1716,1	360	156
HDL TSB-B 140-30-25-4	1	140	30	25,4	118,7	4	851,8	2373,3	490	186
HDL TSB-B 140-30-25-5	1	140	30	25,4	118,7	5	1041,4	3030,5	610	216
HDL TSB-B 140-30-25-6	1	140	30	25,4	118,7	6	1226,6	3687,8	720	246

- C_a and C_{oa} : Modified static and dynamic load capacities, calculated according to DIN 69051/4 standard and ISO3408/5. See Technical description catalogue.

- Check with SHUTON-IPIRANGA in case higher loads or more adjusted nut dimensions are required.

- Check external maximum axial force in the two senses.

For the indicated leads, in case C_a and C_{oa} requirements is lower, there is possibility of smaller size balls.

Maximum force (Peak load CO-CO and TR-TR) calculated with the flange/nut clamping in opposite position to the main support of the shaft, with same load type (traction or compression) in both nut and shaft. For same-side clamping, so different type of load, contact SHUTON-IPIRANGA as peak load is lower.

Nut dimensions									Grease quantity TS
$D_{1, std}$	$D_{1, min}$	D_4	D_6	D_5	L_7	L_1	L_8	L_9	$Q_{Gr} [cm^3]$
210	(205)	239 (234)	268 (263)	20	45	40	215 (210)	241,5 (236,5)	full=913
210	(205)	239 (234)	268 (263)	20	45	40	215 (210)	241,5 (236,5)	full=965
210	(205)	239 (234)	268 (263)	20	45	40	215 (210)	241,5 (236,5)	full=1018
210		236	262	17,5	30	40	215	238,5	full=417
210		236	262	17,5	30	40	215	238,5	full=475
210		236	262	17,5	30	40	215	238,5	full=537
210		236	262	17,5	30	40	215	238,5	full=599
210		236	262	17,5	30	40	215	238,5	full=665
210		236	262	17,5	30	40	215	238,5	full=738
210		236	262	17,5	30	40	215	238,5	full=808
220	(215)	246 (241)	272 (267)	17,5	50	40	225 (220)	248,5 (243,5)	full=864
220	(215)	246 (241)	272 (267)	17,5	50	40	225 (220)	248,5 (243,5)	full=923
220	(215)	249 (244)	278 (273)	20	50	40	225 (220)	251,5 (246,5)	full=1025
220	(215)	249 (244)	278 (273)	20	50	40	225 (220)	251,5 (246,5)	full=1021
220	(215)	252 (247)	284 (279)	22	50	40	225 (220)	254,5 (249,5)	full=1128
220	(215)	252 (247)	284 (279)	22	50	40	225 (220)	254,5 (249,5)	full=1190
220	(215)	252 (247)	284 (279)	22	50	40	225 (220)	254,5 (249,5)	full=1252
220	(215)	252 (247)	284 (279)	22	50	40	225 (220)	254,5 (249,5)	full=1333
210		236	262	17,5	30	40	215	238,5	full=394
210		236	262	17,5	30	40	215	238,5	full=461
210		236	262	17,5	30	40	215	238,5	full=531
210		236	262	17,5	30	40	215	238,5	full=601
210		236	262	17,5	30	40	215	238,5	full=675
210		236	262	17,5	30	40	215	238,5	full=752
210		236	262	17,5	30	40	215	238,5	full=833
220	(215)	246 (241)	272 (267)	17,5	50	40	225 (220)	248,5 (243,5)	full=912
220	(215)	246 (241)	272 (267)	17,5	50	40	225 (220)	248,5 (243,5)	full=968
220	(215)	246 (241)	272 (267)	17,5	50	40	225 (220)	248,5 (243,5)	full=1081
220	(215)	249 (244)	278 (273)	20	50	40	225 (220)	251,5 (246,5)	full=1140
220	(215)	249 (244)	278 (273)	20	50	40	225 (220)	251,5 (246,5)	full=1210
220	(215)	249 (244)	278 (273)	20	50	40	225 (220)	251,5 (246,5)	full=1232
235	(230)	268 (263)	300 (295)	22	60	40	240 (235)	270 (265)	full=648
235	(230)	268 (263)	300 (295)	22	60	40	240 (235)	270 (265)	full=742
235	(230)	268 (263)	300 (295)	22	60	40	240 (235)	270 (265)	full=844
235	(230)	268 (263)	300 (295)	22	60	40	240 (235)	270 (265)	full=947
235	(230)	268 (263)	300 (295)	22	60	40	240 (235)	270 (265)	full=1058

SHUTON-IPIRANGA advises to use the dimensions of the tables, although it is possible to manufacture ball screw with other dimensions. In brackets () second options.

Smaller nut diameters than the first option of the table can reduce the rigidity of the assembly between 5 and 10%. Please consult SHUTON-IPIRANGA.

High Load HDL TS Single nut, DN up to 110.000

Ball screw reference	Number of starts	Nominal diameter (mm)	Lead (mm)	Ball Diameter (mm)	Root diameter (mm)	Circuits	Dynamic load capacity	Static load capacity	Peak load CO-CO TR-TR 'TS'	Nut length
	$l/2$	d_0	P_h	D_w	d_2	i	C_a [kN]	C_{oa} [kN]	F_{max} [kN]	L_{nstd} [mm]
HDL TSB-B 140-30-25-7	1	140	30	25,4	118,7	7	1352,1	4089,4	810	291
HDL TSB-B 140-30-25-8	1	140	30	25,4	118,7	8	1531,2	4746,6	920	321
HDL TSB-B 140-30-25-9	1	140	30	25,4	118,7	9	1707,1	5403,8	1000	351
HDL TSB-B 140-30-25-10	1	140	30	25,4	118,7	10	1880,1	6061,1	1100	379
HDL TSB-B 140-30-25-11	1	140	30	25,4	118,7	11	2050,7	6718,3	1200	409
HDL TSB-B 140-30-25-12	1	140	30	25,4	118,7	12	2219	7375,5	1250	439
HDL TSB-B 140-30-25-13	1	140	30	25,4	118,7	13	2334,5	7777,2	1350	474
HDL TSB(2S)-U 140-32-12-2	2	140	32	12,7	130	2	270,9	879	190	117
HDL TSB(2S)-U 140-32-12-3	2	140	32	12,7	130	3	375,9	1373,5	300	149
HDL TSB(2S)-U 140-32-12-4	2	140	32	12,7	130	4	478,9	1854,2	390	181
HDL TSB(2S)-U 140-32-12-5	2	140	32	12,7	130	5	582,3	2348,6	480	213
HDL TSB(2S)-B 140-32-12-6	2	140	32	12,7	130	6	668	2746,9	570	253
HDL TSB(2S)-B 140-32-12-7	2	140	32	12,7	130	7	750	3131,5	650	291
HDL TSB(2S)-B 140-32-12-8	2	140	32	12,7	130	8	848	3625,9	740	323
HDL TSB(2S)-B 140-32-12-9	2	140	32	12,7	130	9	944,3	4120,4	800	355
HDL TSB(2S)-B 140-32-12-10	2	140	32	12,7	130	10	1022,5	4504,9	860	387
HDL TSB(2S)-B 140-32-12-11	2	140	32	12,7	130	11	1116,1	4999,4	940	419
HDL TSB(2S)-B 140-32-12-12	2	140	32	12,7	130	12	1208,5	5493,8	980	451
HDL TSB(2S)-B 140-32-12-13	2	140	32	12,7	130	13	1287,8	5905,8	1000	485
HDL TSB(2S)-B 140-32-12-14	2	140	32	12,7	130	14	1376,3	6386,6	1050	517
HDL TSB(2S)-B 140-32-12-15	2	140	32	12,7	130	15	1463,8	6867,3	1100	539
HDL TSB-B 140-32-25-2	1	140	32	25,4	118,7	2	462,5	1058,5	220	130
HDL TSB-B 140-32-25-3	1	140	32	25,4	118,7	3	657,7	1715,6	360	162
HDL TSB-B 140-32-25-4	1	140	32	25,4	118,7	4	851,5	2372,6	490	194
HDL TSB-B 140-32-25-5	1	140	32	25,4	118,7	5	1041	3029,6	610	226
HDL TSB-B 140-32-25-6	1	140	32	25,4	118,7	6	1226,1	3686,7	720	258
HDL TSB-B 140-32-25-7	1	140	32	25,4	118,7	7	1351,5	4088,2	800	306
HDL TSB-B 140-32-25-8	1	140	32	25,4	118,7	8	1530,6	4745,2	910	338
HDL TSB-B 140-32-25-9	1	140	32	25,4	118,7	9	1706,4	5402,2	1000	361
HDL TSB-B 140-32-25-10	1	140	32	25,4	118,7	10	1879,4	6059,3	1100	400
HDL TSB-B 140-32-25-11	1	140	32	25,4	118,7	11	2049,9	6716,3	1200	432
HDL TSB-B 140-32-25-12	1	140	32	25,4	118,7	12	2218,2	7373,3	1250	464
HDL TSB(2S)-U 140-40-12-2	2	140	40	12,7	130	2	273,2	891,5	190	128
HDL TSB(2S)-U 140-40-12-3	2	140	40	12,7	130	3	375,2	1371,5	290	168
HDL TSB(2S)-U 140-40-12-4	2	140	40	12,7	130	4	480,4	1865,3	390	208
HDL TSB(2S)-U 140-40-12-5	2	140	40	12,7	130	5	581,3	2345,3	480	248

- C_a and C_{oa} : Modified static and dynamic load capacities, calculated according to DIN 69051/4 standard and ISO3408/5. See Technical description catalogue.

- Check with SHUTON-IPIRANGA in case higher loads or more adjusted nut dimensions are required.

- Check external maximum axial force in the two senses.

For the indicated leads, in case C_a and C_{oa} requirements is lower, there is possibility of smaller size balls.

Maximum force (Peak load CO-CO and TR-TR) calculated with the flange/nut clamping in opposite position to the main support of the shaft, with same load type (traction or compression) in both nut and shaft. For same-side clamping, so different type of load, contact SHUTON-IPIRANGA as peak load is lower.

Nut dimensions									Grease quantity TS
$D_{1, std}$	$D_{1, min}$	D_4	D_6	D_5	L_7	L_1	L_8	L_9	$Q_{Gr} [cm^3]$
235	(230)	268 (263)	300 (295)	22	60	40	240 (235)	270 (265)	full=1307
235	(230)	268 (263)	300 (295)	22	60	40	240 (235)	270 (265)	full=1409
235	(230)	268 (263)	300 (295)	22	60	40	240 (235)	270 (265)	full=1512
235	(230)	268 (263)	300 (295)	22	60	40	240 (235)	270 (265)	full=1598
235	(230)	268 (263)	300 (295)	22	60	40	240 (235)	270 (265)	full=1701
235	(230)	268 (263)	300 (295)	22	60	40	240 (235)	270 (265)	full=1821
235	(230)	268 (263)	300 (295)	22	60	40	240 (235)	270 (265)	full=1964
190		216	242	17,5	30	40	195	218,5	full=163
190		216	242	17,5	30	40	195	218,5	full=213
190		216	242	17,5	30	40	195	218,5	full=270
190		216	242	17,5	30	40	195	218,5	full=324
195	(190)	221 (216)	247 (242)	17,5	40	40	200 (195)	223,5 (218,5)	full=500
195	(190)	221 (216)	247 (242)	17,5	40	40	200 (195)	223,5 (218,5)	full=586
195	(190)	221 (216)	247 (242)	17,5	40	40	200 (195)	223,5 (218,5)	full=639
195	(190)	221 (216)	247 (242)	17,5	40	40	200 (195)	223,5 (218,5)	full=691
195	(190)	221 (216)	247 (242)	17,5	40	40	200 (195)	223,5 (218,5)	full=758
195	(190)	221 (216)	247 (242)	17,5	40	40	200 (195)	223,5 (218,5)	full=804
195	(190)	221 (216)	247 (242)	17,5	40	40	200 (195)	223,5 (218,5)	full=859
195	(190)	224 (219)	253 (248)	20	40	40	200 (195)	226,5 (221,5)	full=927
195	(190)	224 (219)	253 (248)	20	40	40	200 (195)	226,5 (221,5)	full=986
195	(190)	224 (219)	253 (248)	20	40	40	200 (195)	226,5 (221,5)	full=996
235	(230)	268 (263)	300 (295)	22	60	40	240 (235)	270 (265)	full=637
235	(230)	268 (263)	300 (295)	22	60	40	240 (235)	270 (265)	full=736
235	(230)	268 (263)	300 (295)	22	60	40	240 (235)	270 (265)	full=842
235	(230)	268 (263)	300 (295)	22	60	40	240 (235)	270 (265)	full=949
235	(230)	268 (263)	300 (295)	22	60	40	240 (235)	270 (265)	full=1064
235	(230)	268 (263)	300 (295)	22	60	40	240 (235)	270 (265)	full=1319
235	(230)	268 (263)	300 (295)	22	60	40	240 (235)	270 (265)	full=1426
235	(230)	268 (263)	300 (295)	22	60	40	240 (235)	270 (265)	full=1464
235	(230)	268 (263)	300 (295)	22	60	40	240 (235)	270 (265)	full=1624
235	(230)	268 (263)	300 (295)	22	60	40	240 (235)	270 (265)	full=1731
235	(230)	268 (263)	300 (295)	22	60	40	240 (235)	270 (265)	full=1855
190		216	242	17,5	30	40	195	218,5	full=174
190		216	242	17,5	30	40	195	218,5	full=237
190		216	242	17,5	30	40	195	218,5	full=302
190		216	242	17,5	30	40	195	218,5	full=370

SHUTON-IPIRANGA advises to use the dimensions of the tables, although it is possible to manufacture ball screw with other dimensions. In brackets () second options.

Smaller nut diameters than the first option of the table can reduce the rigidity of the assembly between 5 and 10%. Please consult SHUTON-IPIRANGA.

High Load HDL TS Single nut, DN up to 110.000

Ball screw reference	Number of starts	Nominal diameter (mm)	Lead (mm)	Ball Diameter (mm)	Root diameter (mm)	Circuits	Dynamic load capacity	Static load capacity	Peak load CO-CO TR-TR 'TS'	Nut length
	$1/2$	d_0	P_h	D_w	d_2	i	C_a [kN]	C_{oa} [kN]	F_{max} [kN]	$L_{n, std}$ [mm]
HDL TSB(2S)-B 140-40-12-6	2	140	40	12,7	130	6	666,8	2743	550	303
HDL TSB(2S)-B 140-40-12-7	2	140	40	12,7	130	7	748,7	3127	630	350
HDL TSB(2S)-B 140-40-12-8	2	140	40	12,7	130	8	846,5	3620,8	700	388
HDL TSB(2S)-B 140-40-12-9	2	140	40	12,7	130	9	942,5	4114,5	750	428
HDL TSB(2S)-B 140-40-12-10	2	140	40	12,7	130	10	1020,6	4498,5	800	471
HDL TSB(2S)-B 140-40-12-11	2	140	40	12,7	130	11	1114,1	4992,3	840	511
HDL TSB(2S)-B 140-40-12-12	2	140	40	12,7	130	12	1206,3	5486	860	536
HDL TSB(2S)-U 140-40-15-2	2	140	40	15,875	127,1	2	374,8	1111,5	260	135
HDL TSB(2S)-U 140-40-15-3	2	140	40	15,875	127,1	3	523,9	1756,1	400	175
HDL TSB(2S)-U 140-40-15-4	2	140	40	15,875	127,1	4	669	2378,5	530	215
HDL TSB(2S)-U 140-40-15-5	2	140	40	15,875	127,1	5	815,3	3023,2	650	255
HDL TSB(2S)-U 140-40-15-6	2	140	40	15,875	127,1	6	954,5	3645,6	770	295
HDL TSB(2S)-B 140-40-15-7	2	140	40	15,875	127,1	7	1068	4134,6	870	351
HDL TSB(2S)-B 140-40-15-8	2	140	40	15,875	127,1	8	1202,4	4757	950	389
HDL TSB(2S)-B 140-40-15-9	2	140	40	15,875	127,1	9	1316,1	5268,3	1050	436
HDL TSB(2S)-B 140-40-15-10	2	140	40	15,875	127,1	10	1442,9	5868,5	1100	476
HDL TSB(2S)-B 140-40-15-11	2	140	40	15,875	127,1	11	1578,8	6535,4	1150	516
HDL TSB(2S)-B 140-40-15-12	2	140	40	15,875	127,1	12	1702,1	7135,6	1200	539
HDL TSB(2S)-U 140-50-15-2	2	140	50	15,875	127,1	2	378,6	1131,2	260	149
HDL TSB(2S)-U 140-50-15-3	2	140	50	15,875	127,1	3	522,4	1752,2	390	199
HDL TSB(2S)-U 140-50-15-4	2	140	50	15,875	127,1	4	671,2	2395,5	520	249
HDL TSB(2S)-U 140-50-15-5	2	140	50	15,875	127,1	5	813	3016,5	640	299
HDL TSB(2S)-B 140-50-15-6	2	140	50	15,875	127,1	6	928,4	3504,5	720	354
HDL TSB(2S)-B 140-50-15-7	2	140	50	15,875	127,1	7	1065	4125,5	810	422
HDL TSB(2S)-B 140-50-15-8	2	140	50	15,875	127,1	8	1206,5	4791	890	472
HDL TSB(2S)-B 140-50-15-9	2	140	50	15,875	127,1	9	1312,4	5256,7	920	510
HDL TSB(2S)-U 140-50-19-2	2	140	50	19,05	124,1	2	485,5	1341,6	320	156
HDL TSB(2S)-U 140-50-19-3	2	140	50	19,05	124,1	3	680,3	2126,9	490	206
HDL TSB(2S)-U 140-50-19-4	2	140	50	19,05	124,1	4	875	2912,2	650	256
HDL TSB(2S)-U 140-50-19-5	2	140	50	19,05	124,1	5	1065,6	3697,5	800	306
HDL TSB(2S)-B 140-50-19-6	2	140	50	19,05	124,1	6	1209	4253,8	910	364
HDL TSB(2S)-B 140-50-19-7	2	140	50	19,05	124,1	7	1392,7	5039,1	1050	430
HDL TSB(2S)-B 140-50-19-8	2	140	50	19,05	124,1	8	1572,8	5824,4	1100	480
HDL TSB(2S)-B 140-50-19-9	2	140	50	19,05	124,1	9	1709,1	6380,7	1150	522
HDL TSB-U 160-20-15-2	1	160	20	15,875	147,1	2	259,2	779,8	180	90
HDL TSB-U 160-20-15-3	1	160	20	15,875	147,1	3	360,6	1223,5	280	110
HDL TSB-U 160-20-15-4	1	160	20	15,875	147,1	4	459,9	1653,8	380	130
HDL TSB-U 160-20-15-5	1	160	20	15,875	147,1	5	557,2	2084	460	150

- C_a and C_{oa} : Modified static and dynamic load capacities, calculated according to DIN 69051/4 standard and ISO3408/5. See Technical description catalogue.
- Check with SHUTON-IPIRANGA in case higher loads or more adjusted nut dimensions are required.
- Check external maximum axial force in the two senses.

For the indicated leads, in case C_a and C_{oa} requirements is lower, there is possibility of smaller size balls.

Maximum force (Peak load CO-CO and TR-TR) calculated with the flange/nut clamping in opposite position to the main support of the shaft, with same load type (traction or compression) in both nut and shaft. For same-side clamping, so different type of load, contact SHUTON-IPIRANGA as peak load is lower.

Nut dimensions									Grease quantity TS
$D_{1, std}$	$D_{1, min}$	D_4	D_6	D_5	L_7	L_1	L_8	L_9	$Q_{Gr} [cm^3]$
195	(190)	221 (216)	247 (242)	17,5	40	40	200 (195)	223,5 (218,5)	full=558
195	(190)	221 (216)	247 (242)	17,5	40	40	200 (195)	223,5 (218,5)	full=655
195	(190)	221 (216)	247 (242)	17,5	40	40	200 (195)	223,5 (218,5)	full=712
195	(190)	221 (216)	247 (242)	17,5	40	40	200 (195)	223,5 (218,5)	full=775
195	(190)	221 (216)	247 (242)	17,5	40	40	200 (195)	223,5 (218,5)	full=863
195	(190)	221 (216)	247 (242)	17,5	40	40	200 (195)	223,5 (218,5)	full=920
195	(190)	221 (216)	247 (242)	17,5	40	40	200 (195)	223,5 (218,5)	full=935
200		226	252	17,5	30	40	205	228,5	full=232
200		226	252	17,5	30	40	205	228,5	full=310
200		226	252	17,5	30	40	205	228,5	full=396
200		226	252	17,5	30	40	205	228,5	full=478
200		226	252	17,5	30	40	205	228,5	full=569
210	(205)	236 (231)	262 (257)	17,5	45	40	215 (210)	238,5 (233,5)	full=860
210	(205)	236 (231)	262 (257)	17,5	45	40	215 (210)	238,5 (233,5)	full=941
210	(205)	239 (234)	268 (263)	20	45	40	215 (210)	241,5 (236,5)	full=1065
210	(205)	239 (234)	268 (263)	20	45	40	215 (210)	241,5 (236,5)	full=1156
210	(205)	239 (234)	268 (263)	20	45	40	215 (210)	241,5 (236,5)	full=1234
210	(205)	242 (237)	274 (269)	22	45	40	215 (210)	244,5 (239,5)	full=1243
200		226	252	17,5	30	40	205	228,5	full=243
200		226	252	17,5	30	40	205	228,5	full=340
200		226	252	17,5	30	40	205	228,5	full=437
200		226	252	17,5	30	40	205	228,5	full=538
210	(205)	236 (231)	262 (257)	17,5	45	40	215 (210)	238,5 (233,5)	full=771
210	(205)	236 (231)	262 (257)	17,5	45	40	215 (210)	238,5 (233,5)	full=942
210	(205)	236 (231)	262 (257)	17,5	45	40	215 (210)	238,5 (233,5)	full=1039
210	(205)	236 (231)	262 (257)	17,5	45	40	215 (210)	238,5 (233,5)	full=1104
210		236	262	17,5	30	40	215	238,5	full=532
210		236	262	17,5	30	40	215	238,5	full=650
210		236	262	17,5	30	40	215	238,5	full=768
210		236	262	17,5	30	40	215	238,5	full=893
220	(215)	246 (241)	272 (267)	17,5	50	40	225 (220)	248,5 (243,5)	full=1035
220	(215)	249 (244)	278 (273)	20	50	40	225 (220)	251,5 (246,5)	full=1242
220	(215)	249 (244)	278 (273)	20	50	40	225 (220)	251,5 (246,5)	full=1360
220	(215)	249 (244)	278 (273)	20	50	40	225 (220)	251,5 (246,5)	full=1469
220		246	272	17,5	30	40	225	248,5	full=177
220		246	272	17,5	30	40	225	248,5	full=223
220		246	272	17,5	30	40	225	248,5	full=271
220		246	272	17,5	30	40	225	248,5	full=321

SHUTON-IPIRANGA advises to use the dimensions of the tables, although it is possible to manufacture ball screw with other dimensions. In brackets () second options.

Smaller nut diameters than the first option of the table can reduce the rigidity of the assembly between 5 and 10%. Please consult SHUTON-IPIRANGA.

High Load HDL TS Single nut, DN up to 110.000

Ball screw reference	Number of starts	Nominal diameter (mm)	Lead (mm)	Ball Diameter (mm)	Root diameter (mm)	Circuits	Dynamic load capacity	Static load capacity	Peak load CO-CO TR-TR 'TS'	Nut length
	$l/2$	d_0	P_h	D_w	d_2	i	C_a [kN]	C_{oa} [kN]	F_{max} [kN]	$L_{n,std}$ [mm]
HDL TSB-U 160-20-15-6	1	160	20	15,875	147,1	6	654,9	2527,8	560	170
HDL TSB-B 160-20-15-7	1	160	20	15,875	147,1	7	718,5	2783,2	630	203
HDL TSB-B 160-20-15-8	1	160	20	15,875	147,1	8	813,1	3226,9	730	223
HDL TSB-B 160-20-15-9	1	160	20	15,875	147,1	9	906	3670,6	820	243
HDL TSB-B 160-20-15-10	1	160	20	15,875	147,1	10	975,5	3979,9	890	264
HDL TSB-B 160-20-15-11	1	160	20	15,875	147,1	11	1063,8	4410,1	970	284
HDL TSB-B 160-20-15-12	1	160	20	15,875	147,1	12	1159,5	4894,2	1050	304
HDL TSB-B 160-20-15-13	1	160	20	15,875	147,1	13	1232,9	5243,7	1100	325
HDL TSB-B 160-20-15-14	1	160	20	15,875	147,1	14	1313,9	5647,1	1200	345
HDL TSB-B 160-20-15-15	1	160	20	15,875	147,1	15	1404,4	6117,7	1250	363
HDL TSB-U 160-25-15-2	1	160	25	15,875	147,1	2	259	779,5	180	99
HDL TSB-U 160-25-15-3	1	160	25	15,875	147,1	3	360,4	1223	280	124
HDL TSB-U 160-25-15-4	1	160	25	15,875	147,1	4	459,6	1653,1	380	149
HDL TSB-U 160-25-15-5	1	160	25	15,875	147,1	5	556,9	2083,2	460	174
HDL TSB-U 160-25-15-6	1	160	25	15,875	147,1	6	654,5	2526,7	550	199
HDL TSB-B 160-25-15-7	1	160	25	15,875	147,1	7	718,1	2782	630	241
HDL TSB-B 160-25-15-8	1	160	25	15,875	147,1	8	812,6	3225,5	710	266
HDL TSB-B 160-25-15-9	1	160	25	15,875	147,1	9	905,5	3669,1	800	291
HDL TSB-B 160-25-15-10	1	160	25	15,875	147,1	10	975	3978,2	860	318
HDL TSB-B 160-25-15-11	1	160	25	15,875	147,1	11	1063,2	4408,2	930	343
HDL TSB-B 160-25-15-12	1	160	25	15,875	147,1	12	1158,8	4892,1	1000	366
HDL TSB-B 160-25-15-13	1	160	25	15,875	147,1	13	1232,2	5241,5	1050	392
HDL TSB-B 160-25-15-14	1	160	25	15,875	147,1	14	1313,1	5644,7	1150	417
HDL TSB-B 160-25-15-15	1	160	25	15,875	147,1	15	1403,6	6115,1	1200	442
HDL TSB-U 160-25-19-2	1	160	25	19,05	144,1	2	334,8	932,8	220	102
HDL TSB-U 160-25-19-3	1	160	25	19,05	144,1	3	466,9	1468,6	350	127
HDL TSB-U 160-25-19-4	1	160	25	19,05	144,1	4	599,3	2004,5	470	152
HDL TSB-U 160-25-19-5	1	160	25	19,05	144,1	5	728,9	2540,3	580	177
HDL TSB-U 160-25-19-6	1	160	25	19,05	144,1	6	855,8	3076,2	690	202
HDL TSB-U 160-25-19-7	1	160	25	19,05	144,1	7	980	3612	790	227
HDL TSB-B 160-25-19-8	1	160	25	19,05	144,1	8	1077,2	4008,9	900	268
HDL TSB-B 160-25-19-9	1	160	25	19,05	144,1	9	1173	4405,8	990	297
HDL TSB-B 160-25-19-10	1	160	25	19,05	144,1	10	1292	4941,7	1100	322
HDL TSB-B 160-25-19-11	1	160	25	19,05	144,1	11	1409,2	5477,5	1200	347
HDL TSB-B 160-25-19-12	1	160	25	19,05	144,1	12	1524,8	6013,4	1250	362
HDL TSB-B 160-25-19-13	1	160	25	19,05	144,1	13	1619,2	6430,1	1350	397
HDL TSB-B 160-25-19-14	1	160	25	19,05	144,1	14	1735,7	6985,8	1400	422
HDL TSB-B 160-25-19-15	1	160	25	19,05	144,1	15	1851	7541,5	1500	447

- C_a and C_{oa} : Modified static and dynamic load capacities, calculated according to DIN 69051/4 standard and ISO3408/5. See Technical description catalogue.
- Check with SHUTON-IPIRANGA in case higher loads or more adjusted nut dimensions are required.
- Check external maximum axial force in the two senses.

For the indicated leads, in case C_a and C_{oa} requirements is lower, there is possibility of smaller size balls.

Maximum force (Peak load CO-CO and TR-TR) calculated with the flange/nut clamping in opposite position to the main support of the shaft, with same load type (traction or compression) in both nut and shaft. For same-side clamping, so different type of load, contact SHUTON-IPIRANGA as peak load is lower.

Nut dimensions									Grease quantity TS
$D_{1, std}$	$D_{1, min}$	D_4	D_6	D_5	L_7	L_1	L_8	L_9	$Q_{Gr} [cm^3]$
220		246	272	17,5	30	40	225	248,5	full=371
230		256	282	17,5	45	40	235	258,5	full=606
230		256	282	17,5	45	40	235	258,5	full=652
230		256	282	17,5	45	40	235	258,5	full=698
230		256	282	17,5	45	40	235	258,5	full=759
230		256	282	17,5	45	40	235	258,5	full=809
230		259	288	20	45	40	235	261,5	full=851
230		259	288	20	45	40	235	261,5	full=913
230		262	294	22	45	40	235	264,5	full=958
230		262	294	22	45	40	235	264,5	full=993
220		246	272	17,5	30	40	225	248,5	full=179
220		246	272	17,5	30	40	225	248,5	full=233
220		246	272	17,5	30	40	225	248,5	full=289
220		246	272	17,5	30	40	225	248,5	full=348
220		246	272	17,5	30	40	225	248,5	full=406
230		256	282	17,5	45	40	235	258,5	full=644
230		256	282	17,5	45	40	235	258,5	full=698
230		256	282	17,5	45	40	235	258,5	full=752
230		256	282	17,5	45	40	235	258,5	full=826
230		256	282	17,5	45	40	235	258,5	full=884
230		259	288	20	45	40	235	261,5	full=925
230		259	288	20	45	40	235	261,5	full=994
230		259	288	20	45	40	235	261,5	full=1048
230		262	294	22	45	40	235	264,5	full=1102
230		256	282	17,5	30	40	235	258,5	full=482
230		256	282	17,5	30	40	235	258,5	full=549
230		256	282	17,5	30	40	235	258,5	full=616
230		256	282	17,5	30	40	235	258,5	full=690
230		256	282	17,5	30	40	235	258,5	full=764
230		256	282	17,5	30	40	235	258,5	full=842
240	(235)	266 (261)	292 (287)	17,5	50	40	245 (240)	268,5 (263,5)	full=906
240	(235)	269 (264)	298 (293)	20	50	40	245 (240)	271,5 (266,5)	full=1019
240	(235)	269 (264)	298 (293)	20	50	40	245 (240)	271,5 (266,5)	full=1079
240	(235)	272 (267)	304 (299)	22	50	40	245 (240)	274,5 (269,5)	full=1149
240	(235)	272 (267)	304 (299)	22	50	40	245 (240)	274,5 (269,5)	full=1157
240	(235)	272 (267)	304 (299)	22	50	40	245 (240)	274,5 (269,5)	full=1298
240	(235)	272 (267)	304 (299)	22	50	40	245 (240)	274,5 (269,5)	full=1368
240	(235)	272 (267)	304 (299)	22	50	40	245 (240)	274,5 (269,5)	full=1439

SHUTON-IPIRANGA advises to use the dimensions of the tables, although it is possible to manufacture ball screw with other dimensions. In brackets () second options.

Smaller nut diameters than the first option of the table can reduce the rigidity of the assembly between 5 and 10%. Please consult SHUTON-IPIRANGA.

High Load HDL TS Single nut, DN up to 110.000

Ball screw reference	Number of starts	Nominal diameter (mm)	Lead (mm)	Ball Diameter (mm)	Root diameter (mm)	Circuits	Dynamic load capacity	Static load capacity	Peak load CO-CO TR-TR 'TS'	Nut length
	$l/2$	d_0	P_h	D_w	d_2	i	C_a [kN]	C_{oa} [kN]	F_{max} [kN]	$L_{n, std}$ [mm]
HDL TSB-B 160-25-19-16	1	160	25	19,05	144,1	16	1952,2	8017,8	1550	472
HDL TSB-U 160-30-19-2	1	160	30	19,05	144,1	2	339,3	952,1	220	111
HDL TSB-U 160-30-19-3	1	160	30	19,05	144,1	3	470,8	1487,7	350	141
HDL TSB-U 160-30-19-4	1	160	30	19,05	144,1	4	602,8	2023,3	470	171
HDL TSB-U 160-30-19-5	1	160	30	19,05	144,1	5	732,2	2558,8	580	201
HDL TSB-U 160-30-19-6	1	160	30	19,05	144,1	6	858,9	3094,4	690	231
HDL TSB-U 160-30-19-7	1	160	30	19,05	144,1	7	982,9	3630	780	261
HDL TSB-B 160-30-19-8	1	160	30	19,05	144,1	8	1083,6	4046,5	890	310
HDL TSB-B 160-30-19-9	1	160	30	19,05	144,1	9	1182,8	4463,1	970	345
HDL TSB-B 160-30-19-10	1	160	30	19,05	144,1	10	1301,4	4998,6	1050	363
HDL TSB-B 160-30-19-11	1	160	30	19,05	144,1	11	1418,4	5534,2	1150	403
HDL TSB-B 160-30-19-12	1	160	30	19,05	144,1	12	1533,8	6069,8	1200	433
HDL TSB-B 160-30-19-13	1	160	30	19,05	144,1	13	1618,1	6426,8	1250	466
HDL TSB-B 160-30-19-14	1	160	30	19,05	144,1	14	1734,5	6982,2	1300	488
HDL TSB-B 160-30-25-2	1	160	30	25,4	138,7	2	502,7	1251,8	260	126
HDL TSB-B 160-30-25-3	1	160	30	25,4	138,7	3	713,9	2025	420	156
HDL TSB-B 160-30-25-4	1	160	30	25,4	138,7	4	915,7	2761,4	570	186
HDL TSB-B 160-30-25-5	1	160	30	25,4	138,7	5	1113,5	3497,8	700	216
HDL TSB-B 160-30-25-6	1	160	30	25,4	138,7	6	1314,5	4271	840	246
HDL TSB-B 160-30-25-7	1	160	30	25,4	138,7	7	1459,2	4786,4	960	291
HDL TSB-B 160-30-25-8	1	160	30	25,4	138,7	8	1646	5522,8	1100	321
HDL TSB-B 160-30-25-9	1	160	30	25,4	138,7	9	1829,6	6259,2	1200	351
HDL TSB-B 160-30-25-10	1	160	30	25,4	138,7	10	2010,3	6995,6	1300	379
HDL TSB-B 160-30-25-11	1	160	30	25,4	138,7	11	2202,4	7805,6	1400	409
HDL TSB-B 160-30-25-12	1	160	30	25,4	138,7	12	2378,1	8541,9	1450	439
HDL TSB-B 160-30-25-13	1	160	30	25,4	138,7	13	2511,1	9057,4	1550	474
HDL TSB-B 160-32-25-2	1	160	32	25,4	138,7	2	502,6	1251,5	260	130
HDL TSB-B 160-32-25-3	1	160	32	25,4	138,7	3	713,7	2024,6	420	162
HDL TSB-B 160-32-25-4	1	160	32	25,4	138,7	4	915,4	2760,8	570	194
HDL TSB-B 160-32-25-5	1	160	32	25,4	138,7	5	1113,1	3497	700	226
HDL TSB-B 160-32-25-6	1	160	32	25,4	138,7	6	1314,1	4270	830	258
HDL TSB-B 160-32-25-7	1	160	32	25,4	138,7	7	1458,8	4785,3	950	306
HDL TSB-B 160-32-25-8	1	160	32	25,4	138,7	8	1645,5	5521,5	1050	338
HDL TSB-B 160-32-25-9	1	160	32	25,4	138,7	9	1829	6257,7	1150	360
HDL TSB-B 160-32-25-10	1	160	32	25,4	138,7	10	2009,7	6993,9	1250	400
HDL TSB-B 160-32-25-11	1	160	32	25,4	138,7	11	2201,7	7803,8	1350	432
HDL TSB-B 160-32-25-12	1	160	32	25,4	138,7	12	2377,4	8540	1450	464

- C_a and C_{oa} : Modified static and dynamic load capacities, calculated according to DIN 69051/4 standard and ISO3408/5. See Technical description catalogue.

- Check with SHUTON-IPIRANGA in case higher loads or more adjusted nut dimensions are required.

- Check external maximum axial force in the two senses.

For the indicated leads, in case C_a and C_{oa} requirements is lower, there is possibility of smaller size balls.

Maximum force (Peak load CO-CO and TR-TR) calculated with the flange/nut clamping in opposite position to the main support of the shaft, with same load type (traction or compression) in both nut and shaft. For same-side clamping, so different type of load, contact SHUTON-IPIRANGA as peak load is lower.

Nut dimensions									Grease quantity TS
$D_{1, std}$	$D_{1, min}$	D_4	D_6	D_5	L_7	L_1	L_8	L_9	$Q_{Gr} [cm^3]$
240	(235)	275 (270)	310 (305)	24	50	40	245 (240)	277,5 (272,5)	full=1509
230		256	282	17,5	30	40	235	258,5	full=452
230		256	282	17,5	30	40	235	258,5	full=528
230		256	282	17,5	30	40	235	258,5	full=604
230		256	282	17,5	30	40	235	258,5	full=688
230		256	282	17,5	30	40	235	258,5	full=771
230		256	282	17,5	30	40	235	258,5	full=858
240	(235)	266 (261)	292 (287)	17,5	50	40	245 (240)	268,5 (263,5)	full=943
240	(235)	266 (261)	292 (287)	17,5	50	40	245 (240)	268,5 (263,5)	full=1065
240	(235)	269 (264)	298 (293)	20	50	40	245 (240)	271,5 (266,5)	full=1067
240	(235)	269 (264)	298 (293)	20	50	40	245 (240)	271,5 (266,5)	full=1202
240	(235)	272 (267)	304 (299)	22	50	40	245 (240)	274,5 (269,5)	full=1281
240	(235)	272 (267)	304 (299)	22	50	40	245 (240)	274,5 (269,5)	full=1396
240	(235)	272 (267)	304 (299)	22	50	40	245 (240)	274,5 (269,5)	full=1431
260	(250)	293 (283)	325 (315)	22	60	40	265 (255)	295 (285)	full=726
260	(250)	293 (283)	325 (315)	22	60	40	265 (255)	295 (285)	full=836
260	(250)	293 (283)	325 (315)	22	60	40	265 (255)	295 (285)	full=946
260	(250)	293 (283)	325 (315)	22	60	40	265 (255)	295 (285)	full=1073
260	(250)	293 (283)	325 (315)	22	60	40	265 (255)	295 (285)	full=1192
260	(250)	293 (283)	325 (315)	22	60	40	265 (255)	295 (285)	full=1456
260	(250)	293 (283)	325 (315)	22	60	40	265 (255)	295 (285)	full=1574
260	(250)	293 (283)	325 (315)	22	60	40	265 (255)	295 (285)	full=1710
260	(250)	293 (283)	325 (315)	22	60	40	265 (255)	295 (285)	full=1810
260	(250)	293 (283)	325 (315)	22	60	40	265 (255)	295 (285)	full=1912
260	(250)	293 (283)	325 (315)	22	60	40	265 (255)	295 (285)	full=2047
260	(250)	296 (286)	331 (321)	24	60	40	265 (255)	298 (288)	full=2212
260	(250)	293 (283)	325 (315)	22	60	40	265 (255)	295 (285)	full=714
260	(250)	293 (283)	325 (315)	22	60	40	265 (255)	295 (285)	full=829
260	(250)	293 (283)	325 (315)	22	60	40	265 (255)	295 (285)	full=944
260	(250)	293 (283)	325 (315)	22	60	40	265 (255)	295 (285)	full=1076
260	(250)	293 (283)	325 (315)	22	60	40	265 (255)	295 (285)	full=1199
260	(250)	293 (283)	325 (315)	22	60	40	265 (255)	295 (285)	full=1470
260	(250)	293 (283)	325 (315)	22	60	40	265 (255)	295 (285)	full=1593
260	(250)	293 (283)	325 (315)	22	60	40	265 (255)	295 (285)	full=1647
260	(250)	293 (283)	325 (315)	22	60	40	265 (255)	295 (285)	full=1839
260	(250)	293 (283)	325 (315)	22	60	40	265 (255)	295 (285)	full=1945
260	(250)	293 (283)	325 (315)	22	60	40	265 (255)	295 (285)	full=2086

SHUTON-IPIRANGA advises to use the dimensions of the tables, although it is possible to manufacture ball screw with other dimensions. In brackets () second options.

Smaller nut diameters than the first option of the table can reduce the rigidity of the assembly between 5 and 10%. Please consult SHUTON-IPIRANGA.

High load PKL TS Single nut, momentary extreme peak loads

Ball screw reference	Number of starts	Nominal diameter (mm)	Lead (mm)	Ball Diameter (mm)	Root diameter (mm)	Circuits	Dynamic load capacity	Static load capacity	Peak load CO-CO TR-TR 'TS'	Nut length
	$l/2$	d_0	P_h	D_w	d_2	i	C_a [kN]	C_{oa} [kN]	F_{max} [kN]	L_{nstd} [mm]
PKL TSB-B 63-20-15-2	1	63	20	15,875	49,1	2	128,6	205,1	110	89
PKL TSB-B 63-20-15-3	1	63	20	15,875	49,1	3	187,6	345,4	180	109
PKL TSB-B 63-20-15-4	1	63	20	15,875	49,1	4	245,7	485,7	250	129
PKL TSB-B 63-20-15-5	1	63	20	15,875	49,1	5	302,2	626	320	149
PKL TSB-B 63-20-15-6	1	63	20	15,875	49,1	6	357,4	766,3	380	169
PKL TSB-B 63-20-15-7	1	63	20	15,875	49,1	7	411,3	906,7	440	189
PKL TSB-B 63-20-15-8	1	63	20	15,875	49,1	8	464,2	1047	490	209
PKL TSB-B 63-20-15-9	1	63	20	15,875	49,1	9	516,2	1187,3	550	229
PKL TSB-B 63-20-15-10	1	63	20	15,875	49,1	10	567,3	1327,6	600	249
PKL TSB-B 63-20-15-11	1	63	20	15,875	49,1	11	599,5	1403,2	680	274
PKL TSB-B 80-25-19-2	1	80	25	19,05	63,1	2	191	328,6	180	105
PKL TSB-B 80-25-19-3	1	80	25	19,05	63,1	3	271,3	532	290	130
PKL TSB-B 80-25-19-4	1	80	25	19,05	63,1	4	356,2	751,1	400	155
PKL TSB-B 80-25-19-5	1	80	25	19,05	63,1	5	438,8	970,2	500	180
PKL TSB-B 80-25-19-6	1	80	25	19,05	63,1	6	514,8	1173,6	590	205
PKL TSB-B 80-25-19-7	1	80	25	19,05	63,1	7	593,7	1392,7	680	230
PKL TSB-B 80-25-19-8	1	80	25	19,05	63,1	8	671	1611,7	770	255
PKL TSB-B 80-25-19-9	1	80	25	19,05	63,1	9	716,9	1721,3	860	293
PKL TSB-B 80-25-19-10	1	80	25	19,05	63,1	10	792,2	1940,3	950	318
PKL TSB-B 80-25-19-11	1	80	25	19,05	63,1	11	866,4	2159,4	1050	343
PKL TSB-B 80-25-19-12	1	80	25	19,05	63,1	12	931,3	2347,2	1100	366
PKL TSB-B 100-25-19-2	1	100	25	19,05	83,1	2	223	432	230	105
PKL TSB-B 100-25-19-3	1	100	25	19,05	83,1	3	318,2	704	380	130
PKL TSB-B 100-25-19-4	1	100	25	19,05	83,1	4	412,7	976	510	155
PKL TSB-B 100-25-19-5	1	100	25	19,05	83,1	5	505	1247,9	640	180
PKL TSB-B 100-25-19-6	1	100	25	19,05	83,1	6	595,1	1519,9	770	205
PKL TSB-B 100-25-19-7	1	100	25	19,05	83,1	7	683,3	1791,9	880	230
PKL TSB-B 100-25-19-8	1	100	25	19,05	83,1	8	741,8	1951,9	990	268
PKL TSB-B 100-25-19-9	1	100	25	19,05	83,1	9	831,4	2239,9	1150	293
PKL TSB-B 100-25-19-10	1	100	25	19,05	83,1	10	911,7	2495,9	1200	318
PKL TSB-B 100-25-19-11	1	100	25	19,05	83,1	11	998,5	2783,9	1300	343
PKL TSB-B 100-25-19-12	1	100	25	19,05	83,1	12	1076,6	3039,9	1400	366
PKL TSB-B 100-25-19-13	1	100	25	19,05	83,1	13	1161,3	3327,9	1500	391
PKL TSB-B 100-25-19-14	1	100	25	19,05	83,1	14	1237,6	3583,8	1550	416
PKL TSB-B 100-25-19-15	1	100	25	19,05	83,1	15	1291,2	3743,8	1650	445
PKL TSB-B 100-25-19-16	1	100	25	19,05	83,1	16	1373,6	4031,8	1700	470
PKL TSB-U 120-25-19-2	1	120	25	19,05	103,1	2	254,1	551,8	310	100
PKL TSB-U 120-25-19-3	1	120	25	19,05	103,1	3	356,5	876,4	470	125
PKL TSB-U 120-25-19-4	1	120	25	19,05	103,1	4	458,7	1201	640	150
PKL TSB-U 120-25-19-5	1	120	25	19,05	103,1	5	562,8	1541,8	810	175
PKL TSB-U 120-25-19-6	1	120	25	19,05	103,1	6	660,6	1866,4	970	200

- C_a and C_{oa} : Modified static and dynamic load capacities, calculated according to DIN 69051/4 standard and ISO3408/5. See Technical description catalogue.

- Check with SHUTON-IPIRANGA in case higher loads or more adjusted nut dimensions are required.

- Check external maximum axial force in the two senses.

For the indicated leads, in case C_a and C_{oa} requirements is lower, there is possibility of smaller size balls.

Maximum force (Peak load CO-CO and TR-TR) calculated with the flange/nut clamping in opposite position to the main support of the shaft, with same load type (traction or compression) in both nut and shaft. For same-side clamping, so different type of load, contact SHUTON-IPIRANGA as peak load is lower.

Nut dimensions									Grease quantity TS
$D_{1, std}$	$D_{1, min}$	D_4	D_6	D_5	L_7	L_1	L_8	L_9	$Q_{Gr} [cm^3]$
120		140	160	13,5	45	25	125	142,5	full=80
120		140	160	13,5	45	25	125	142,5	full=92
120		140	160	13,5	45	25	125	142,5	full=103
120		140	160	13,5	45	25	125	142,5	full=117
120		140	160	13,5	45	25	125	142,5	full=130
120		140	160	13,5	45	25	125	142,5	full=145
120		140	160	13,5	45	25	125	142,5	full=160
120		143	166	15,5	45	25	125	145,5	full=176
120		143	166	15,5	45	25	125	145,5	full=192
120		143	166	15,5	45	25	125	145,5	full=205
150		176	202	17,5	50	40	155	178,5	full=138
150		176	202	17,5	50	40	155	178,5	full=162
150		176	202	17,5	50	40	155	178,5	full=185
150		176	202	17,5	50	40	155	178,5	full=206
150		176	202	17,5	50	40	155	178,5	full=232
150		176	202	17,5	50	40	155	178,5	full=258
150		176	202	17,5	50	40	155	178,5	full=284
150		176	202	17,5	50	40	155	178,5	full=335
150		176	202	17,5	50	40	155	178,5	full=358
150		179	208	20	50	40	155	181,5	full=382
150		179	208	20	50	40	155	181,5	full=406
175	(170)	201 (196)	227 (222)	17,5	50	40	180 (175)	203,5 (198,5)	full=171
175	(170)	201 (196)	227 (222)	17,5	50	40	180 (175)	203,5 (198,5)	full=198
175	(170)	201 (196)	227 (222)	17,5	50	40	180 (175)	203,5 (198,5)	full=227
175	(170)	201 (196)	227 (222)	17,5	50	40	180 (175)	203,5 (198,5)	full=256
175	(170)	201 (196)	227 (222)	17,5	50	40	180 (175)	203,5 (198,5)	full=284
175	(170)	201 (196)	227 (222)	17,5	50	40	180 (175)	203,5 (198,5)	full=318
175	(170)	204 (199)	233 (228)	20	50	40	180 (175)	206,5 (201,5)	full=386
175	(170)	204 (199)	233 (228)	20	50	40	180 (175)	206,5 (201,5)	full=412
175	(170)	207 (202)	239 (234)	22	50	40	180 (175)	209,5 (204,5)	full=444
175	(170)	207 (202)	239 (234)	22	50	40	180 (175)	209,5 (204,5)	full=470
175	(170)	207 (202)	239 (234)	22	50	40	180 (175)	209,5 (204,5)	full=496
175	(170)	207 (202)	239 (234)	22	50	40	180 (175)	209,5 (204,5)	full=527
175	(170)	210 (205)	245 (240)	24	50	40	180 (175)	212,5 (207,5)	full=564
175	(170)	210 (205)	245 (240)	24	50	40	180 (175)	212,5 (207,5)	full=603
175	(170)	210 (205)	245 (240)	24	50	40	180 (175)	212,5 (207,5)	full=624
190		216	242	17,5	40	40	195	218,5	full=234
190		216	242	17,5	40	40	195	218,5	full=268
190		216	242	17,5	40	40	195	218,5	full=300
190		216	242	17,5	40	40	195	218,5	full=334
190		216	242	17,5	40	40	195	218,5	full=371

SHUTON-IPIRANGA advises to use the dimensions of the tables, although it is possible to manufacture ball screw with other dimensions. In brackets () second options.

Smaller nut diameters than the first option of the table can reduce the rigidity of the assembly between 5 and 10%. Please consult SHUTON-IPIRANGA.

High load PKL TS Single nut, momentary extreme peak loads

Ball screw reference	Number of starts	Nominal diameter (mm)	Lead (mm)	Ball Diameter (mm)	Root diameter (mm)	Circuits	Dynamic load capacity	Static load capacity	Peak load CO-CO TR-TR 'TS'	Nut length
	$l/2$	d_0	P_h	D_w	d_2	i	C_{da} [kN]	C_{oa} [kN]	F_{max} [kN]	L_{nstd} [mm]
PKL TSB-U 120-25-19-7	1	120	25	19,05	103,1	7	756,3	2191	1150	225
PKL TSB-U 120-25-19-8	1	120	25	19,05	103,1	8	850,3	2515,6	1250	250
PKL TSB-U 120-25-19-9	1	120	25	19,05	103,1	9	946,4	2856,4	1350	275
PKL TSB-U 120-25-19-10	1	120	25	19,05	103,1	10	1037,4	3181	1500	300
PKL TSB-B 120-25-19-11	1	120	25	19,05	103,1	11	1106,1	3408,2	1650	343
PKL TSB-B 120-25-19-12	1	120	25	19,05	103,1	12	1195,1	3732,8	1750	366
PKL TSB-B 120-25-19-13	1	120	25	19,05	103,1	13	1258,9	3943,8	1900	395
PKL TSB-B 120-25-19-14	1	120	25	19,05	103,1	14	1349,5	4284,6	1950	420
PKL TSB-B 120-25-19-15	1	120	25	19,05	103,1	15	1439,1	4625,4	2100	445
PKL TSB-B 120-25-19-16	1	120	25	19,05	103,1	16	1517,8	4917,6	2100	470
PKL TSB-B 120-25-19-17	1	120	25	19,05	103,1	17	1605,8	5258,4	2200	487
PKL TSB-U 140-25-19-2	1	140	25	19,05	123,1	2	280,4	672,1	380	101
PKL TSB-U 140-25-19-3	1	140	25	19,05	123,1	3	388,9	1049,1	580	126
PKL TSB-U 140-25-19-4	1	140	25	19,05	123,1	4	501,6	1442,5	770	151
PKL TSB-U 140-25-19-5	1	140	25	19,05	123,1	5	608,2	1819,5	960	176
PKL TSB-U 140-25-19-6	1	140	25	19,05	123,1	6	716,1	2212,9	1150	201
PKL TSB-U 140-25-19-7	1	140	25	19,05	123,1	7	818,2	2590	1300	226
PKL TSB-U 140-25-19-8	1	140	25	19,05	123,1	8	921,9	2983,4	1500	251
PKL TSB-B 140-25-19-9	1	140	25	19,05	123,1	9	997,2	3245,6	1700	293
PKL TSB-B 140-25-19-10	1	140	25	19,05	123,1	10	1098	3639,1	1850	318
PKL TSB-B 140-25-19-11	1	140	25	19,05	123,1	11	1177,8	3934,1	2000	347
PKL TSB-B 140-25-19-12	1	140	25	19,05	123,1	12	1276,2	4327,5	2150	362
PKL TSB-B 140-25-19-13	1	140	25	19,05	123,1	13	1363,8	4671,8	2250	395
PKL TSB-B 140-25-19-14	1	140	25	19,05	123,1	14	1460	5065,2	2400	420
PKL TSB-B 140-25-19-15	1	140	25	19,05	123,1	15	1555,1	5458,6	2500	445
PKL TSB-B 140-25-19-16	1	140	25	19,05	123,1	16	1633,9	5770	2600	472
PKL TSB-U 160-25-19-2	1	160	25	19,05	143,1	2	299,1	776,1	440	102
PKL TSB-U 160-25-19-3	1	160	25	19,05	143,1	3	417,1	1222	700	127
PKL TSB-U 160-25-19-4	1	160	25	19,05	143,1	4	535,4	1667,8	930	152
PKL TSB-U 160-25-19-5	1	160	25	19,05	143,1	5	651,2	2113,6	1150	177
PKL TSB-U 160-25-19-6	1	160	25	19,05	143,1	6	761,2	2543	1350	202
PKL TSB-U 160-25-19-7	1	160	25	19,05	143,1	7	872,3	2988,8	1600	227
PKL TSB-B 160-25-19-8	1	160	25	19,05	143,1	8	962,3	3335,6	1800	268
PKL TSB-B 160-25-19-9	1	160	25	19,05	143,1	9	1047,9	3665,9	1950	297
PKL TSB-B 160-25-19-10	1	160	25	19,05	143,1	10	1154,2	4111,7	2150	322
PKL TSB-B 160-25-19-11	1	160	25	19,05	143,1	11	1258,9	4557,6	2350	347
PKL TSB-B 160-25-19-12	1	160	25	19,05	143,1	12	1362,2	5003,4	2550	362
PKL TSB-B 160-25-19-13	1	160	25	19,05	143,1	13	1446,5	5350,2	2700	397
PKL TSB-B 160-25-19-14	1	160	25	19,05	143,1	14	1538,8	5746,5	2800	422
PKL TSB-B 160-25-19-15	1	160	25	19,05	143,1	15	1642	6208,8	2900	447
PKL TSB-B 160-25-19-16	1	160	25	19,05	143,1	16	1744	6671,2	3050	472

- C_a and C_{oa} : Modified static and dynamic load capacities, calculated according to DIN 69051/4 standard and ISO3408/5. See Technical description catalogue.

- Check with SHUTON-IPIRANGA in case higher loads or more adjusted nut dimensions are required.

- Check external maximum axial force in the two senses.

For the indicated leads, in case C_a and C_{oa} requirements is lower, there is possibility of smaller size balls.

Maximum force (Peak load CO-CO and TR-TR) calculated with the flange/nut clamping in opposite position to the main support of the shaft, with same load type (traction or compression) in both nut and shaft. For same-side clamping, so different type of load, contact SHUTON-IPIRANGA as peak load is lower.

Nut dimensions									Grease quantity TS
$D_{1, std}$	$D_{1, min}$	D_4	D_6	D_5	L_7	L_1	L_8	L_9	$Q_{Gr} [cm^3]$
190		216	242	17,5	40	40	195	218,5	full=410
190		216	242	17,5	40	40	195	218,5	full=452
190		216	242	17,5	40	40	195	218,5	full=493
190		216	242	17,5	40	40	195	218,5	full=542
195	(190)	230 (225)	265 (260)	24	50	40	200 (195)	232,5 (227,5)	full=553
195	(190)	230 (225)	265 (260)	24	50	40	200 (195)	232,5 (227,5)	full=586
195	(190)	230 (225)	265 (260)	24	50	40	200 (195)	232,5 (227,5)	full=636
195	(190)	233 (228)	271 (266)	26	50	40	200 (195)	235,5 (230,5)	full=670
195	(190)	233 (228)	271 (266)	26	50	40	200 (195)	235,5 (230,5)	full=704
195	(190)	233 (228)	271 (266)	26	50	40	200 (195)	235,5 (230,5)	full=746
195	(190)	233 (228)	271 (266)	26	50	40	200 (195)	235,5 (230,5)	full=755
210		236	262	17,5	30	40	215	238,5	full=271
210		236	262	17,5	30	40	215	238,5	full=311
210		236	262	17,5	30	40	215	238,5	full=348
210		236	262	17,5	30	40	215	238,5	full=390
210		236	262	17,5	30	40	215	238,5	full=432
210		236	262	17,5	30	40	215	238,5	full=477
210		236	262	17,5	30	40	215	238,5	full=524
220	(215)	255 (250)	290 (285)	24	50	40	225 (220)	257,5 (252,5)	full=562
220	(215)	255 (250)	290 (285)	24	50	40	225 (220)	257,5 (252,5)	full=600
220	(215)	258 (253)	296 (291)	26	50	40	225 (220)	260,5 (255,5)	full=661
220	(215)	258 (253)	296 (291)	26	50	40	225 (220)	260,5 (255,5)	full=657
220	(215)	262 (257)	304 (299)	29	50	40	225 (220)	264,5 (259,5)	full=733
220	(215)	262 (257)	304 (299)	29	50	40	225 (220)	264,5 (259,5)	full=773
220	(215)	262 (257)	304 (299)	29	50	40	225 (220)	264,5 (259,5)	full=813
220	(215)	262 (257)	304 (299)	29	50	40	225 (220)	264,5 (259,5)	full=857
230		256	282	17,5	30	40	235	258,5	full=314
230		256	282	17,5	30	40	235	258,5	full=357
230		256	282	17,5	30	40	235	258,5	full=400
230		256	282	17,5	30	40	235	258,5	full=445
230		256	282	17,5	30	40	235	258,5	full=497
230		256	282	17,5	30	40	235	258,5	full=547
240	(235)	275 (270)	310 (305)	24	50	40	245 (240)	277,5 (272,5)	full=585
240	(235)	278 (273)	316 (311)	26	50	40	245 (240)	280,5 (275,5)	full=659
240	(235)	278 (273)	316 (311)	26	50	40	245 (240)	280,5 (275,5)	full=697
240	(235)	282 (277)	324 (319)	29	50	40	245 (240)	284,5 (279,5)	full=742
240	(235)	282 (277)	324 (319)	29	50	40	245 (240)	284,5 (279,5)	full=746
240	(235)	282 (277)	324 (319)	29	50	40	245 (240)	284,5 (279,5)	full=837
240	(235)	282 (277)	324 (319)	29	50	40	245 (240)	284,5 (279,5)	full=892
240	(235)	287 (282)	334 (329)	32	50	40	245 (240)	289,5 (284,5)	full=937
240	(235)	287 (282)	334 (329)	32	50	40	245 (240)	289,5 (284,5)	full=973

SHUTON-IPIRANGA advises to use the dimensions of the tables, although it is possible to manufacture ball screw with other dimensions. In brackets () second options.

Smaller nut diameters than the first option of the table can reduce the rigidity of the assembly between 5 and 10%. Please consult SHUTON-IPIRANGA.

NOTE

Handwriting practice area consisting of 25 horizontal dotted lines.

SHUTON·IPIRANGA

location and contacts

Headquarters

Polígono Industrial Goain
C/ Subinoa, 5
01170 Legutiano. Álava · SPAIN
P.O. Box 654
01080 Vitoria-Gasteiz - SPAIN
Phone: +34 945 465 629

Urnieta plant

Polígono Industrial Erratzu
Parcela G3. Pabellón 221
20130 Urnieta. Gipuzkoa · SPAIN
P.O. Box 65
20130 Urnieta - SPAIN
Phone: +34 943 336 370

Contact:

info@shuton-ipiranga.com



HEADQUARTERS

Polígono Industrial Goiaín
C/ Subinoa, 5
01170 Legutiano, Álava · SPAIN
P.O. Box 654
01080 Vitoria-Gasteiz · SPAIN
Phone: +34 945 465 629

URNIETA PLANT

Polígono Industrial Erratzu
Parcela G3, Pabellón 221
20130 Urnieta, Gipuzkoa · SPAIN
P.O. Box 65
20130 Urnieta · SPAIN
Phone: +34 943 336 370

ROLLON®
BY TIMKEN