



Feather hand (mini-parallel hand) Double acting/single acting

FH100 Series

● Operational stroke length: 8, 11, 14, 18, 20mm



RRC
GRC
RV3*
NHS
HR
LN

FH100 Specifications

Descriptions	FH100									
	FH110-D	FH112-D	FH116-D	FH120-D	FH125-D	FH110-0	FH112-0	FH116-0	FH120-0	FH125-0
Actuation	Double acting					Single acting				
Working fluid	Compressed air									
Max. working pressure MPa	0.7									
Min. working pressure MPa	0.15					0.25				
Withstanding pressure MPa	1.05									
Ambient temperature °C	5 to 60									
Port size	M3×0.5		M5×0.8			M3×0.5		M5×0.8		
Open and closed stroke length mm	8	11	14	18	20	8	11	14	18	20
Product weight g	51	71	124	176	284	51	71	124	177	286
Repeatability (default) mm	±0.03									
Max. cycle rate cycle/sec.	3									
Cushion	Open side rubber cushion									
Option	Proximity switch (2 wire/3 wire) * Closed side speed control valve									

* Integrated speed control valve is available only for double acting.

Switch specifications

Descriptions	Proximity 2 wire	Proximity 3 wire
	T2H/V	T3H/V
Applications	Programmable controller	Programmable controller, relay
Output method	-	NPN output
Power voltage	-	10 to 28 VDC
Load voltage/current	10 to 30 VDC, 5 to 20 mA (Note 1)	30 VDC or less, 100mA or less
Light	LED (ON lighting)	
Leakage current	1mA or less	10 μA or less

Note 1: Max. load current above: 20 mA at 25°C. The current will be lower than 20mA if ambient temperature around switch is higher than 25°C. (5 to 10mA with 60°C)

FH500
HBL
HDL
HMD
HJL
BHE
CKG
CK
CKA
CKS
CKF
CKJ
CKL2
CKL2
*-HC
CKH2
CKLB2
NCK/
SCK/FCK
FJ
FK

Ending

How to order

Without switch



With switch



A Bore size

B Option

C Small jaw
Note 1

D Switch model no.
Note 2
* Indicates lead wire length.

E Switch quantity

F End mount
Note 3

⚠ Note on model no. selection

Note 1: Refer to pages 412 to 413 for the dimensions and applicable model of the small jaw. When ordered as an option, two are included on delivery.

Note 2: Switches other than (D) switch model no. are available. (Custom order) Refer to Ending 1 for details.

Note 3: When with end mount (model no. B), select switch with radial lead wire (model no. T*V).
The end mount is attached at delivery.

Symbol	Descriptions			
A Bore size				
10	φ10			
12	φ12			
16	φ16			
20	φ20			
25	φ25			
B Option				
D	Standard (double acting)			
O	Single acting (normally open)			
Z	Double acting integrated speed control valve			
C Small jaw				
Blank	Without small jaw			
Y1	With small jaw material (S50C)			
Y2	With small jaw material (MC nylon)			
D Switch model no.				
Axial lead wire	Radial lead wire	Contact	Indicator	Lead wire
T2H*	T2V*	Proximity	1 color indicator type	2-wire
T3H*	T3V*			3-wire
*Lead wire length				
Blank	1m (standard)			
3	3m (option)			
5	5m (option)			
E Switch quantity				
R	One on right (port) side open position			
D	Two			
F End mount				
Blank	Without end mount			
B	With end mount			

<Example of model number>

FH112-ZY1-T2V-D-B

Model: Feather hand (mini-parallel hand)

- A** Bore size : φ12
- B** Option : Double acting integrated speed control valve
- C** Small jaw : Small jaw material (S50C)
- D** Switch model no.: Proximity T2V switch, lead wire 1m
- E** Switch quantity : 2
- F** End mount : With end mount

How to order end mount



Symbol	Descriptions	
A Bore size		
10	φ10	
12	φ12	
16	φ16	
20	φ20	
25	φ25	

How to order switch



Switch model no.
(Item above (D))

RRC
GRC
RV3*
NHS
HR
LN
FH100
HAP
BSA2
BHA/ BHG
LHA
LHAG
HKP
HLA/ HLB
HLAG/ HLBG
HEP
HCP
HMF
HMFb
HFP
HLC
HGP
FH500
HBL
HDL
HMD
HJL
BHE
CKG
CK
CKA
CKS
CKF
CKJ
CKL2
CKL2 *-HC
CKH2
CKLB2
NCK/ SCK/FCK
FJ
FK
Ending

Feather hand (mini-parallel hand)
Hand

Internal structure and parts list

● Standard (double acting)/O (normally open) type

● Speed control valve

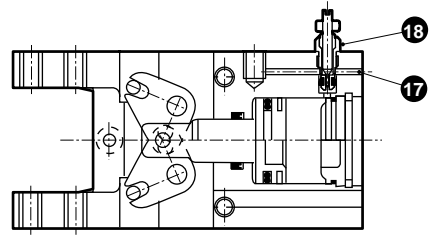
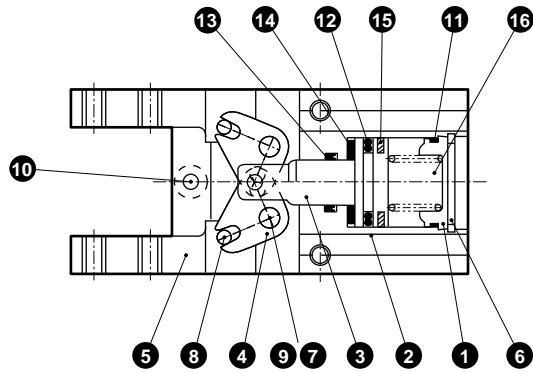

Spring of 16 is not contained in standard (double acting) type.

No.	Parts name	Material	Remarks	No.	Parts name	Material	Remarks
1	Cylinder guard	Acetar resin		10	Hexagon socket head cap bolt	Alloy steel	
2	Body	Aluminum alloy	Lubrication alumite treatment	11	Cylinder gasket	Nitrile rubber	
3	Piston	Stainless steel		12	Piston packing seal	Nitrile rubber	
4	Arm	Stainless steel	Heat treatment	13	Rod packing seal	Nitrile rubber	
5	Master key	Alloy steel	Heat treatment	14	Cushion	Urethane rubber	
6	Snap ring	Stainless steel		15	Magnet		Nickeling
7	Fulcrum axis	Alloy steel	Heat treatment	16	Spring	Stainless steel	
8	Operation axis	Alloy steel	Heat treatment	17	Steel ball	Stainless steel	
9	Hexagon socket head set screw	Stainless steel		18	Flow control valve assembly		

Gripping power performance data

Gripping power that functions to open and closed directions with jaw length ℓ of hand at supply pressure 0.15 to 0.7 MPa is shown.

- Open direction (↔) - - - (shown with broken line)
- Closed direction (↔) — (shown with continuous line)

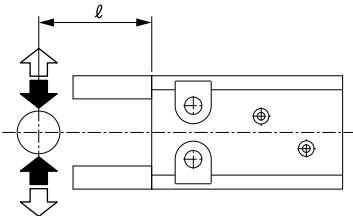

(Note) Single acting type closed side gripping power is decreased by 25 to 30% comparing to double acting type.

Grip performance data indicates the grip for one jaw.

Since two jaws are used, double the grip in the graph when making a selection.

Restriction range for jaw length ℓ

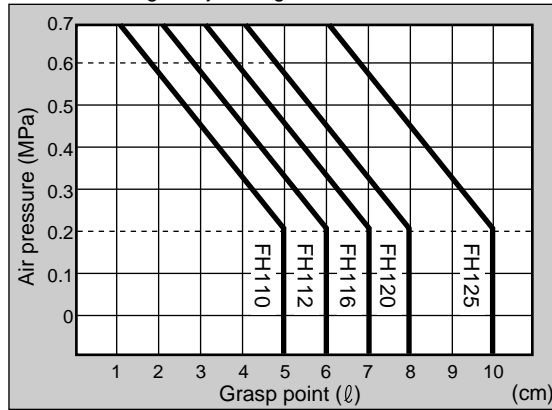

● FH110

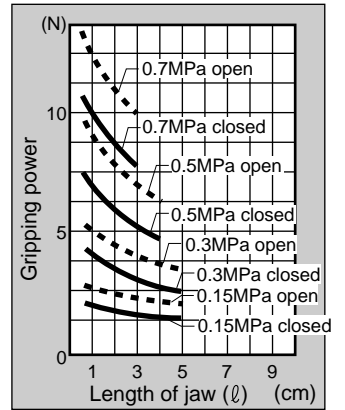

● FH112

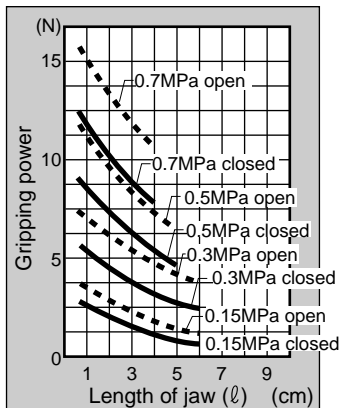

● FH116

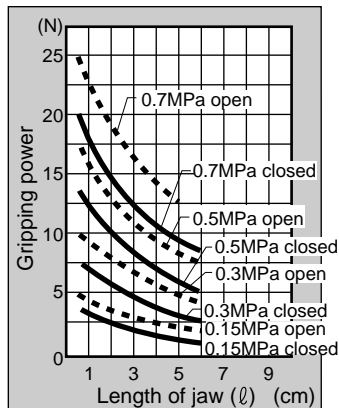

● FH120

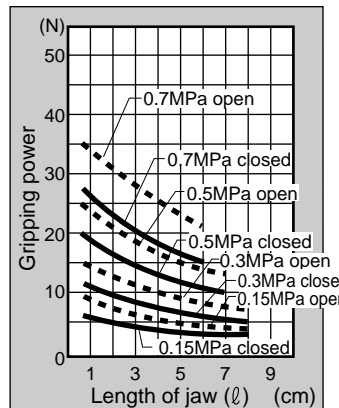

● FH125

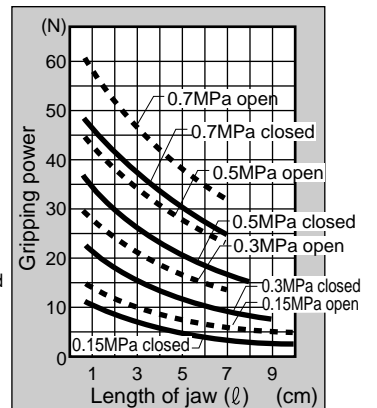

Dimensions



● FH110-D/FH110-O

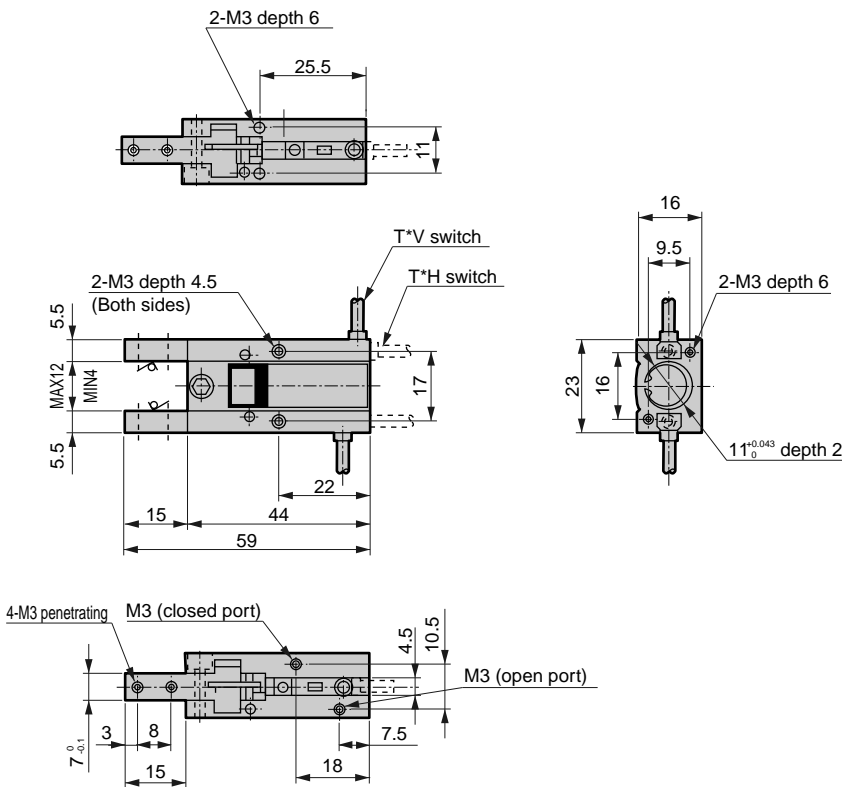

● FH112-D/FH112-O

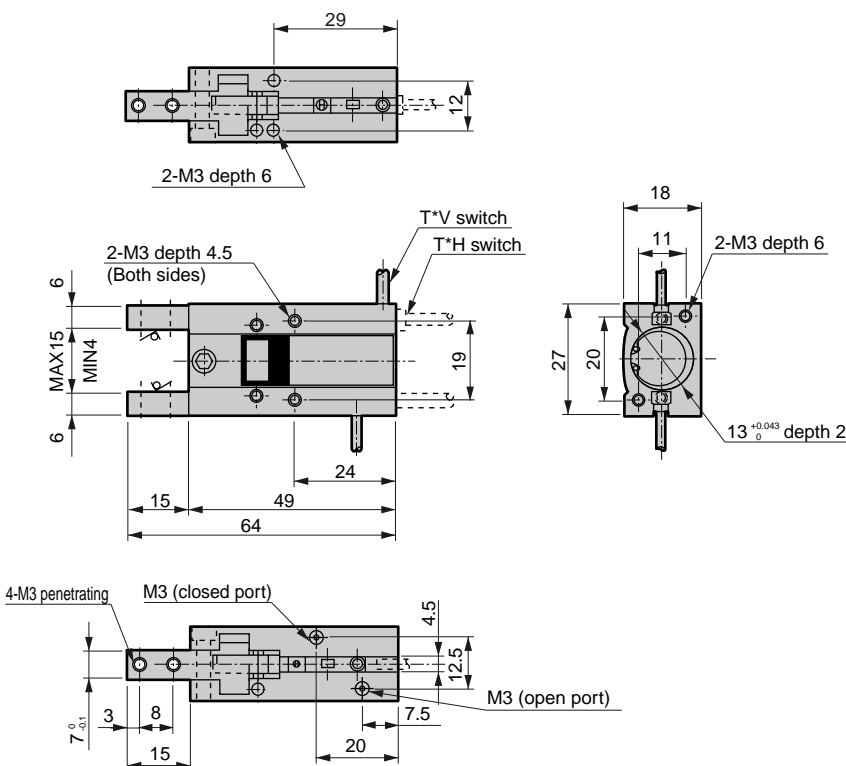

● Speed control valve (FH110-Z)

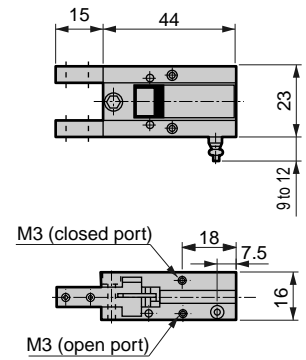

● With end mount

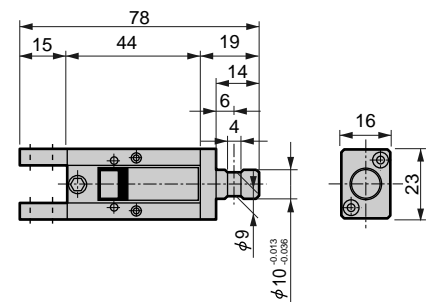

● Speed control valve (FH112-Z)

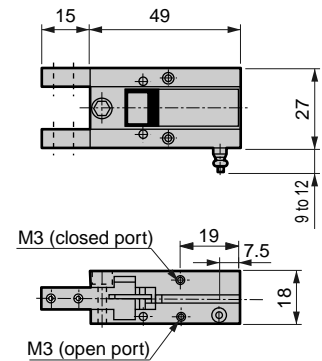

● With end mount

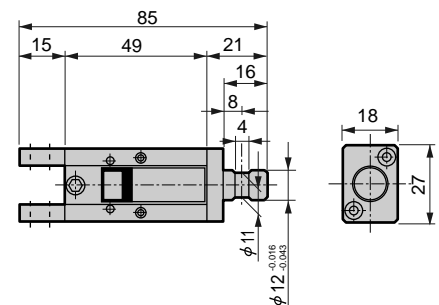

RRC
GRC
RV3*
NHS
HR
LN
FH100
HAP
BSA2
BHA/BHG
LHA
LHAG
HKP
HLA/HLB
HLAG/HLBG
HEP
HCP
HMF
HMFb
HFP
HLC
HGP
FH500
HL
HDL
HMD
HJL
BHE
CKG
CK
CKA
CKS
CKF
CKJ
CKL2
CKL2 *-HC
CKH2
CKLB2
NCK/SCK/FCK
FJ
FK
Ending

Feather hand (mini-parallel hand)
Hand



Dimensions

● FH116-D/FH116-O

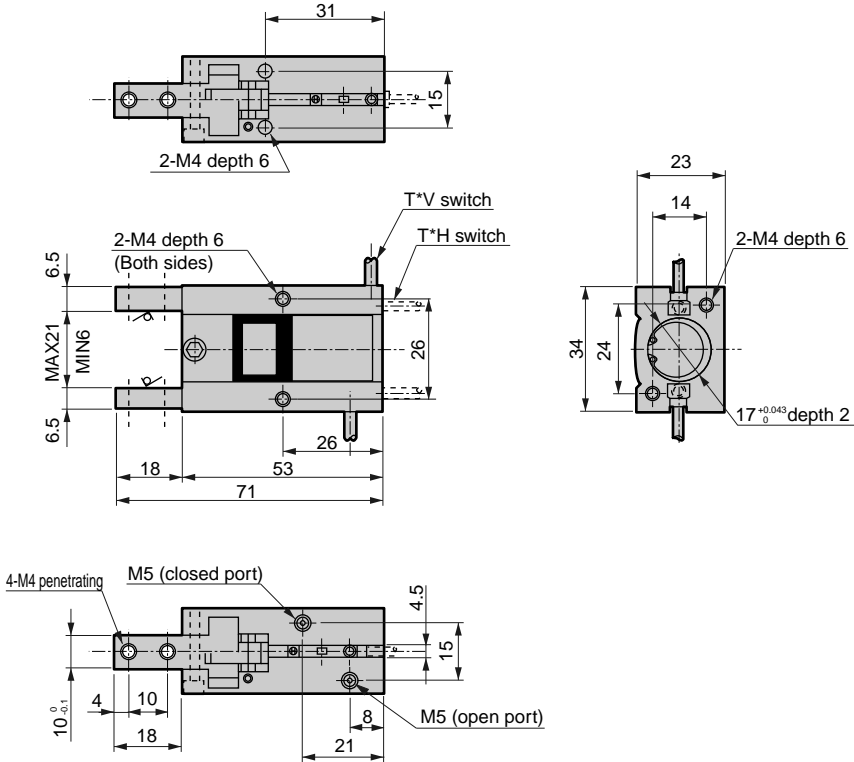

● FH120-D/FH120-O

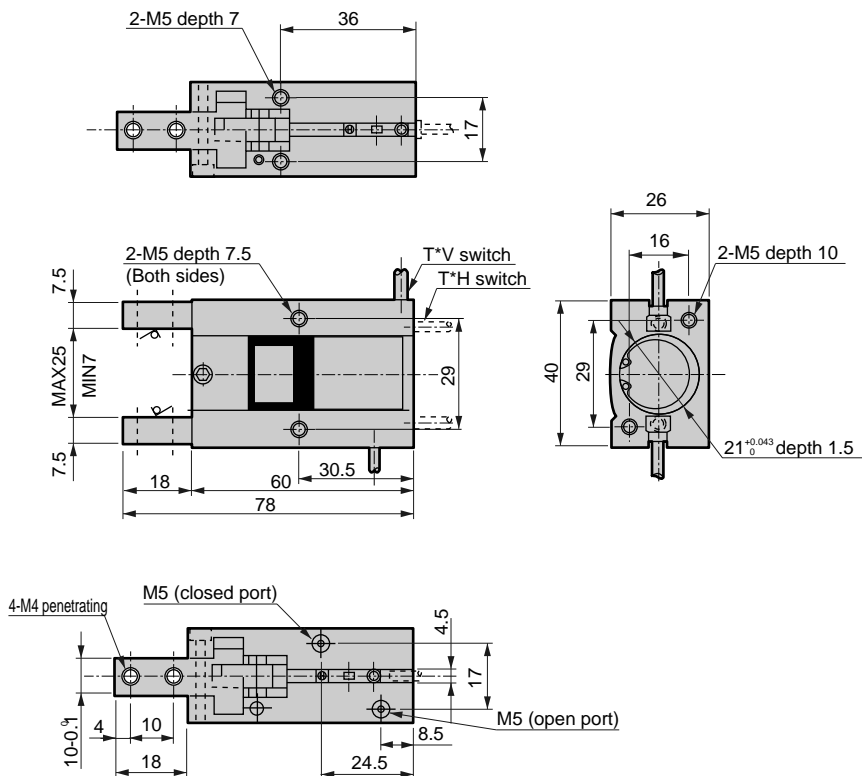

● Speed control valve (FH116-Z)

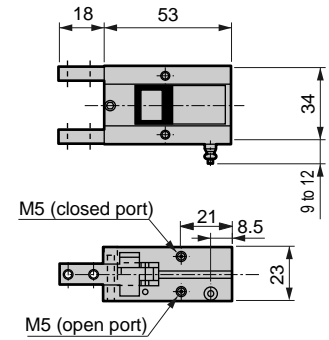

● With end mount

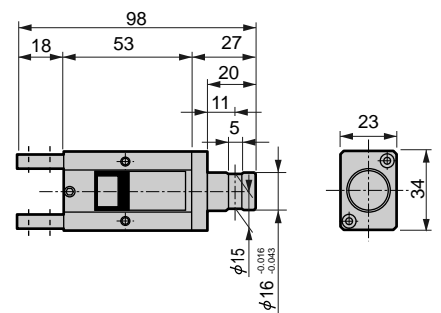

● Speed control valve (FH120-Z)

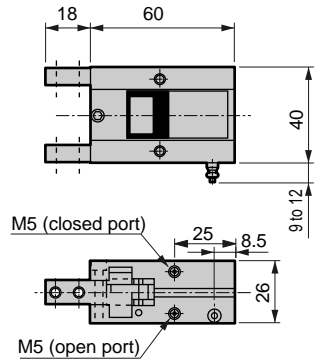

● With end mount

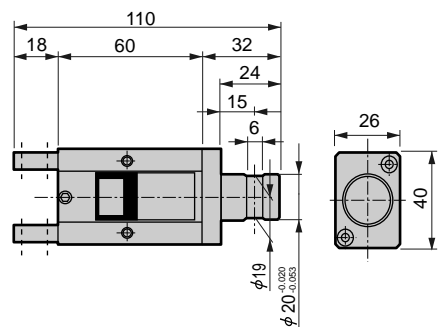

Dimensions



● FH125-D/FH125-O

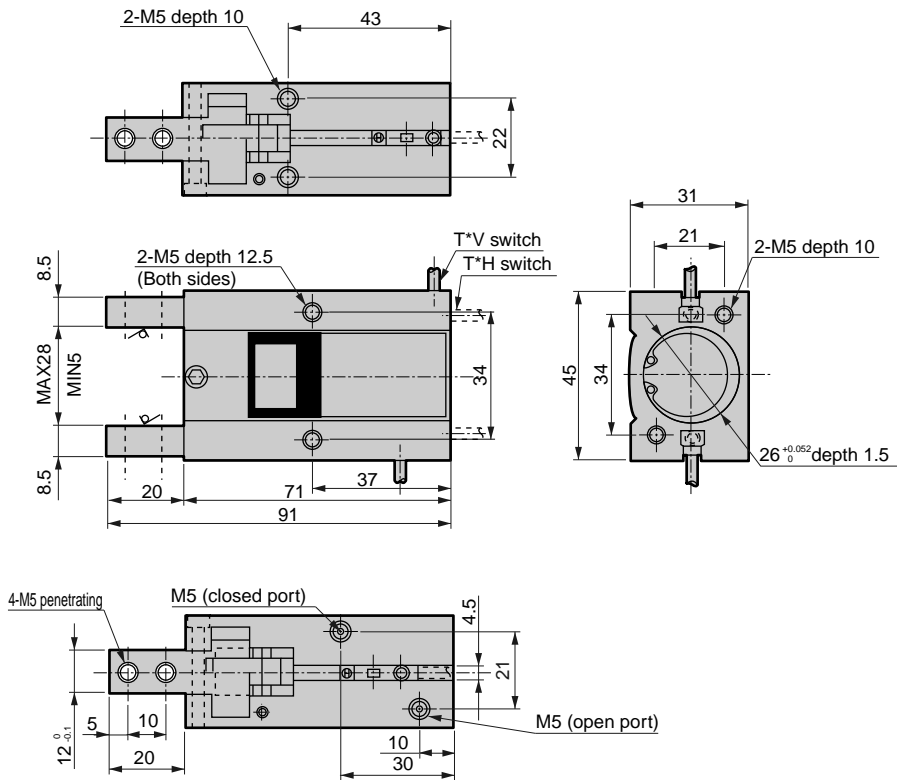

● Speed control valve (FH125-Z)

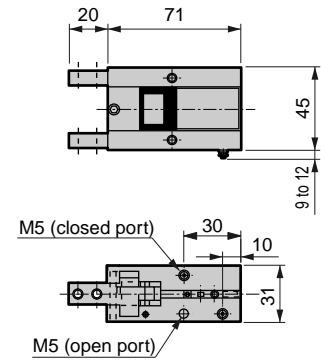

● With end mount

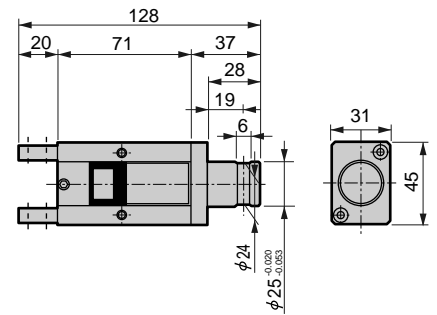

RRC
GRC
RV3*
NHS
HR
LN
FH100
HAP
BSA2
BHA/BHG
LHA
LHAG
HKP
HLA/HLB
HLAG/HLBG
HEP
HCP
HMF
HMFb
HFP
HLC
HGP
FH500
HL
HDL
HMD
HJL
BHE
CKG
CK
CKA
CKS
CKF
CKJ
CKL2
CKL2 *-HC
CKH2
CKLB2
NCK/ SCK/FCK
FJ
FK
Ending

Feather hand (mini-parallel hand)
Hand