

Needle valve with adjusting dial, check valve

# DVL-S Series

Needle valve with adjusting dial, needle valve/oil-prohibited

# DVL-N Series

● Port size:  $\varnothing 4$ ,  $\varnothing 6$ ,  $\varnothing 8$ ,  $\varnothing 10$ ,  $\varnothing 12$

JIS symbol



## Specifications

### ● Needle valve with adjusting dial, check valve DVL-S

Item	DVL-S-06					DVL-S-08		DVL-S-10			
	020		080		160	240		400			
Compatible tube O.D.	mm	$\varnothing 4$	$\varnothing 6$	$\varnothing 4$	$\varnothing 6$	$\varnothing 6$	$\varnothing 6$	$\varnothing 8$	$\varnothing 8$	$\varnothing 10$	$\varnothing 12$
Working fluid		Compressed air									
Max. working pressure	MPa	1.0 ( $\approx 150$ psi, 10 bar)									
Min. working pressure	MPa	0.1 ( $\approx 15$ psi, 1 bar) (*3)									
Proof pressure	MPa	1.5 ( $\approx 220$ psi, 15 bar)									
Fluid temperature	$^{\circ}\text{C}$	5 (41 $^{\circ}\text{F}$ ) to 60 (140 $^{\circ}\text{F}$ ) (no freezing. *2)									
Ambient temperature	$^{\circ}\text{C}$	0 (32 $^{\circ}\text{F}$ ) to 60 (140 $^{\circ}\text{F}$ ) (no freezing)									
Weight	g	54	48	54	48	48	60	61	82	86	88
Needle control range		1 to 12 rotations					1 to 13 rotations				
Free flow	Flow rate $\ell/\text{min}(\text{ANR})$	170	300	170	300	300	400	550	900	1100	1200
	Eff. X-sectional area $\text{mm}^2$	2.5	4.5	2.5	4.5	4.5	6	8	13.5	16.5	18
Controlled flow	Flow rate $\ell/\text{min}(\text{ANR})$	18		80		160	240		440		
	Eff. X-sectional area $\text{mm}^2$	0.25		1.2		2.4	3.6		6.6		

\*1: Flow rate is the atmospheric pressure conversion at 0.5 MPa.

\*2: Freezing may occur due to adiabatic expansion depending on the air quality (dew point).

\*3: Evacuating up to -100 kPa is possible only in the direction of free flow. (Needle control is not available)

### ● Needle valve with adjusting dial, needle valve/oil-prohibited DVL-N

Item	DVL-N-06					DVL-N-08		DVL-N-10			
	020		080		160	240		400			
Compatible tube O.D.	mm	$\varnothing 4$	$\varnothing 6$	$\varnothing 4$	$\varnothing 6$	$\varnothing 6$	$\varnothing 6$	$\varnothing 8$	$\varnothing 8$	$\varnothing 10$	$\varnothing 12$
Working fluid		Compressed air/ $\text{N}_2$ gas/low vacuum									
Max. working pressure	MPa	0.7 ( $\approx 100$ psi, 7 bar)									
Negative pressure	kPa	-100 ( $\approx 15$ psi, -1 bar)									
Proof pressure	MPa	1.5 ( $\approx 220$ psi, 15 bar)									
Fluid temperature	$^{\circ}\text{C}$	5 (41 $^{\circ}\text{F}$ ) to 60 (140 $^{\circ}\text{F}$ ) (no freezing. *2)									
Ambient temperature	$^{\circ}\text{C}$	0 (32 $^{\circ}\text{F}$ ) to 60 (140 $^{\circ}\text{F}$ ) (no freezing)									
Weight	g	54	48	54	48	48	60	61	82	86	88
Needle control range		1 to 12 rotations					1 to 13 rotations				
Flow rate	$\ell/\text{min}(\text{ANR})$	18		80		160	240		440		
Effective cross-sectional area	$\text{mm}^2$	0.25		1.2		2.4	3.6		6.6		

\*1: Flow rate is the atmospheric pressure conversion at 0.5 MPa.

\*2: Freezing may occur due to adiabatic expansion depending on the air quality (dew point).

## How to order

**DVL - S - 06 - H66 - 020**

Model No.

**A** Control method

**B** Body size

**C** Compatible tube O.D.

Refer to the table below for the body size, Compatible tube O.D. and flow rate combination.

**D** Flow rate

Code	Description
<b>A Control method (oil removal)</b>	
<b>S</b>	Check valve
<b>N</b>	Needle valve (oil-prohibited)
<b>B Body size</b>	
<b>06</b>	1/8 thread equivalent
<b>08</b>	1/4 thread equivalent
<b>10</b>	3/8 thread equivalent
<b>C Compatible tube O.D.</b>	
<b>H44</b>	ø4
<b>H66</b>	ø6
<b>H88</b>	ø8
<b>H1010</b>	ø10
<b>H1212</b>	ø12
<b>D Flow rate</b> *1	
<b>020</b>	18 ℓ/min(ANR)
<b>080</b>	80 ℓ/min(ANR)
<b>160</b>	160 ℓ/min(ANR)
<b>240</b>	240 ℓ/min(ANR)
<b>400</b>	440 ℓ/min(ANR)



### Precautions for model No. selection

\*1: The flow rate is the guide value at 0.5 MPa.

\*2: DVL-S and DVL-N can be identified with the color of the push ring.

DVL-S: White  
DVL-N: Blue

### Combination of body size, Compatible tube O.D., and flow rate

	<b>B Body size</b>						
	<b>06</b>		<b>08</b>		<b>10</b>		
<b>C Compatible tube O.D.</b>	H44	H66	H66	H88	H88	H1010	H1212
<b>D Flow rate</b>							
<b>020</b>	●	●					
<b>080</b>	●	●					
<b>160</b>		●					
<b>240</b>			●	●			
<b>400</b>					●	●	●

F.R.L.
F.R.
F (Filtr)
R (Reg)
L (Lub)
Drain Separ
Mech Press SW
Res press exh valve
SlowStart
Anti-bac/Bac-remove Filtr
Film Resist FR
Oil-ProhR
Med Press FR
No Cu/ PTFE FRL
Outdrs FRL
Adapter Joiner Press Gauge
CompFRL
LgFRL
PrecsR
VacF/R
Clean FR
ElecPneuR
AirBoost
Speed Ctrl
Silncr
CheckV/ other
Fit/Tube
Nozzle
Air Unit
PressCompn
Electro Press SW
ContactSW
AirSens
PresSW Cool
Air Flo Sens/Ctrl
WaterR/Sens
TotAirSys (Total Air)
TotAirSys (Gamma)
Gas generator
RefrDry
DesicDry
HiPolymDry
MainFiltr
Dischrg etc
Ending

- F.R.L.
- F.R.
- F (Filtr)
- R (Reg)
- L (Lub)
- Drain Separ
- Mech Press SW
- Res press exh valve
- SlowStart
- Anti-bac/Bac-remove Filtr
- Film Resist FR
- Oil-ProhR
- Med Press FR
- No Cu/PTFE FRL
- Outdrs FRL
- Adapter Joiner Press Gauge
- CompFRL
- LgFRL
- PrecsR
- VacF/R
- Clean FR
- ElecPneur
- AirBoost
- Speed Ctrl**
- Silncr**
- CheckV/other
- Fit/Tube
- Nozzle
- Air Unit
- PrecsCompn
- Electro Press SW
- ContactSW
- AirSens
- PresSW Cool
- Air Flo Sens/Ctrl
- WaterRiSens
- TotAirSys (Total Air)
- TotAirSys (Gamma)
- Gas generator
- RefrDry
- DesicDry
- HiPolymDry
- MainFiltr
- Dischrg etc
- Ending

## Flow characteristics

\*The flow characteristics graph gives reference values and does not guarantee the values.

● DVL-\*-020

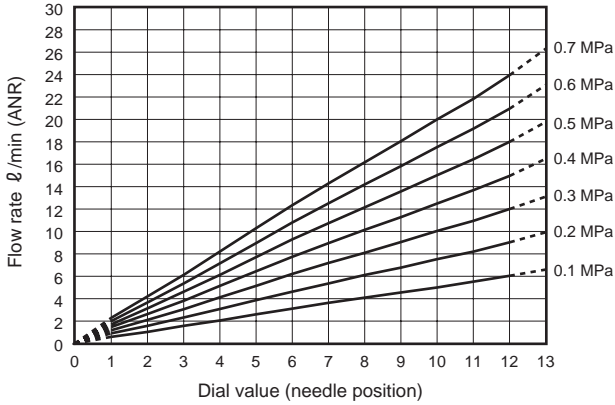

● DVL-\*-080

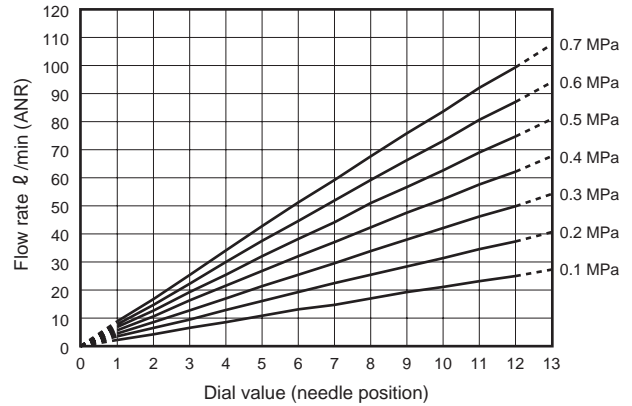

● DVL-\*-160

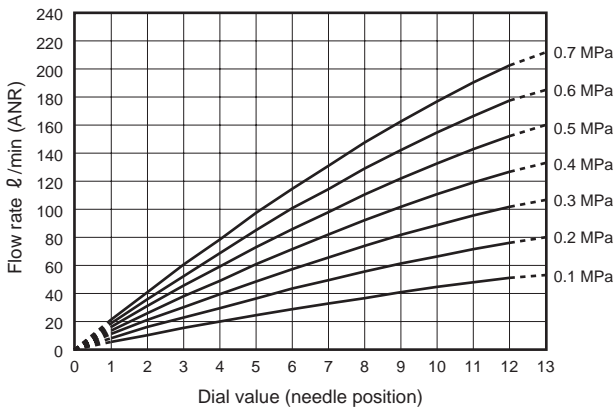

● DVL-\*-240

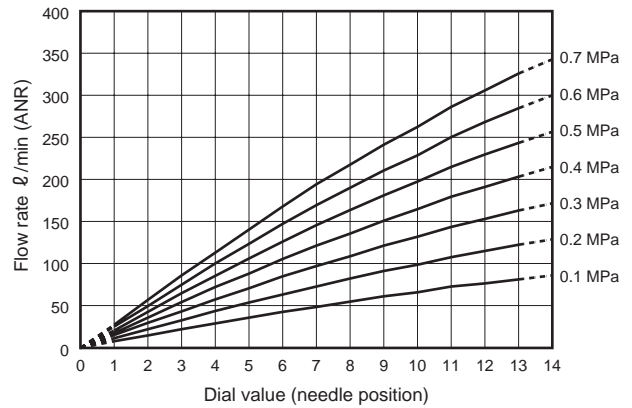

● DVL-\*-400

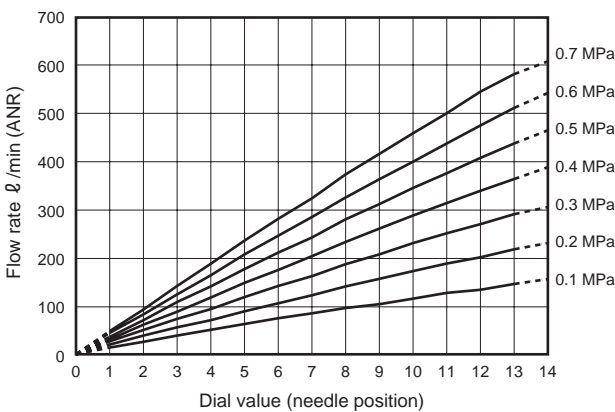

### Internal structure and parts list

#### ● DVL-S

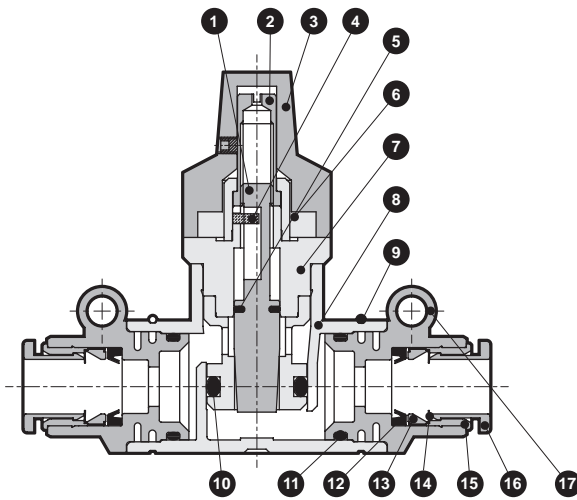
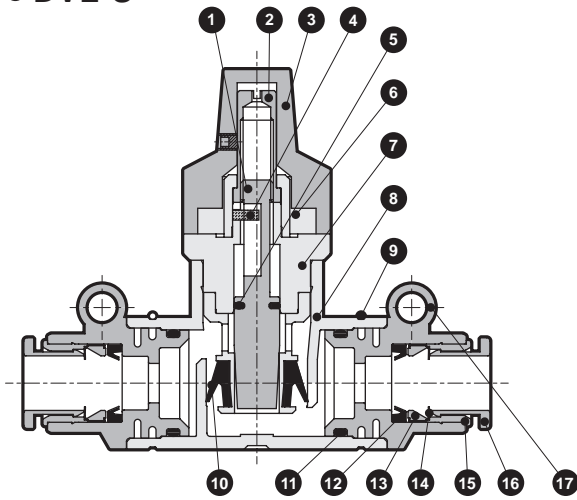

Part No.	Part name	Material
1	Needle	Brass
2	Rotary shaft	Brass
3	Dial	Aluminum alloy, polyamide, etc.
4	Parallel pin	Stainless steel
5	O-ring	Nitrile rubber
6	Guide bush	Brass
7	Check bracket	Brass
8	Body	Polybutylene terephthalate
9	Stopper ring	Stainless steel
10	Check packing	Hydrogenated nitrile rubber
11	O-ring	Nitrile rubber
12	Packing	Nitrile rubber
13	Holder	Brass or polyether sulfone
14	Chuck	Stainless steel
15	Outer ring	Brass
16	Push ring	Polybutylene terephthalate or polyacetal
17	Joint case	Polybutylene terephthalate

\*1: All the brass parts have electroless nickel plating.  
 \*2: Some structures differ depending on the type. (No material changed)

Part No.	Part name	Material
1	Needle	Brass
2	Rotary shaft	Brass
3	Dial	Aluminum alloy, polyamide, etc.
4	Parallel pin	Stainless steel
5	O-ring	Fluoro rubber
6	Guide bush	Brass
7	Check bracket	Brass
8	Body	Polybutylene terephthalate
9	Stopper ring	Stainless steel
10	O-ring	Hydrogenated nitrile rubber
11	O-ring	Hydrogenated nitrile rubber
12	Packing	Hydrogenated nitrile rubber
13	Holder	Brass or polyether sulfone
14	Chuck	Stainless steel
15	Outer ring	Brass
16	Push ring	Polybutylene terephthalate or polyacetal
17	Joint case	Polybutylene terephthalate

\*1: All the brass parts have electroless nickel plating.  
 \*2: Some structures differ depending on the type. (No material changed)

### Dimensions

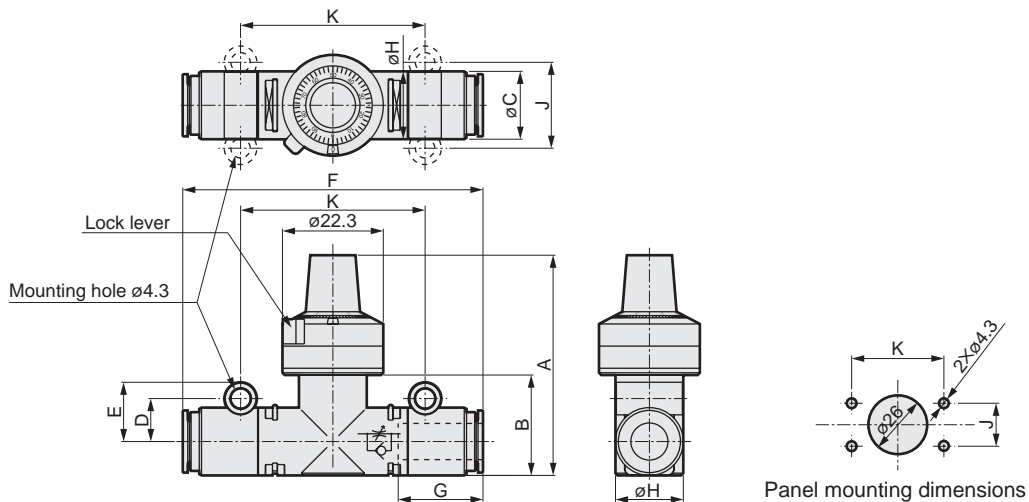

Model No.	Compatible tube O.D.	A	B	C	D	E	F	H	J	K	G (tube insert length)
DVL-*-06-H44-*	ø4	45.5	17	12	8.1	11.6	55	12	16.2	30.8	12.9
DVL-*-06-H66-*	ø6			13			49.5				13.7
DVL-*-08-H66-*	ø6	50	22.5	13	9.5	13.1	64	15	19	41	18
DVL-*-08-H88-*	ø8			15			66.5				19
DVL-*-10-H88-*	ø8	58	29	18	11.5	15.1	71	20	23	47	21
DVL-*-10-H1010-*	ø10			18			75				21
DVL-*-10-H1212-*	ø12			20.4			79				22

F.R.L.  
 F.R.  
 F (Filtr)  
 R (Reg)  
 L (Lub)  
 Drain Separ  
 Mech Press SW  
 Res press exh valve  
 SlowStart  
 Anti-bac/Bac-remove Filtr  
 Film Resist FR  
 Oil-ProhR  
 Med Press FR  
 No Cu/ PTFE FRL  
 Oudrds FRL  
 Adapter Joiner  
 Press Gauge  
 CompFRL  
 LgFRL  
 PrecsR  
 VacF/R  
 Clean FR  
 ElecPneuR  
 AirBoost  
 Speed Ctrl  
 Silncr  
 CheckV/ other  
 Fit/Tube  
 Nozzle  
 Air Unit  
 PresCompn  
 Electro Press SW  
 ContactSW  
 AirSens  
 PresSW Cool  
 Air Flo Sens/Ctrl  
 WaterRSens  
 TotAirSys (Total Air)  
 TotAirSys (Gamma)  
 Gas generator  
 RefrDry  
 DesiccDry  
 HiPolymDry  
 MainFiltr  
 Dischrg etc  
 Ending