

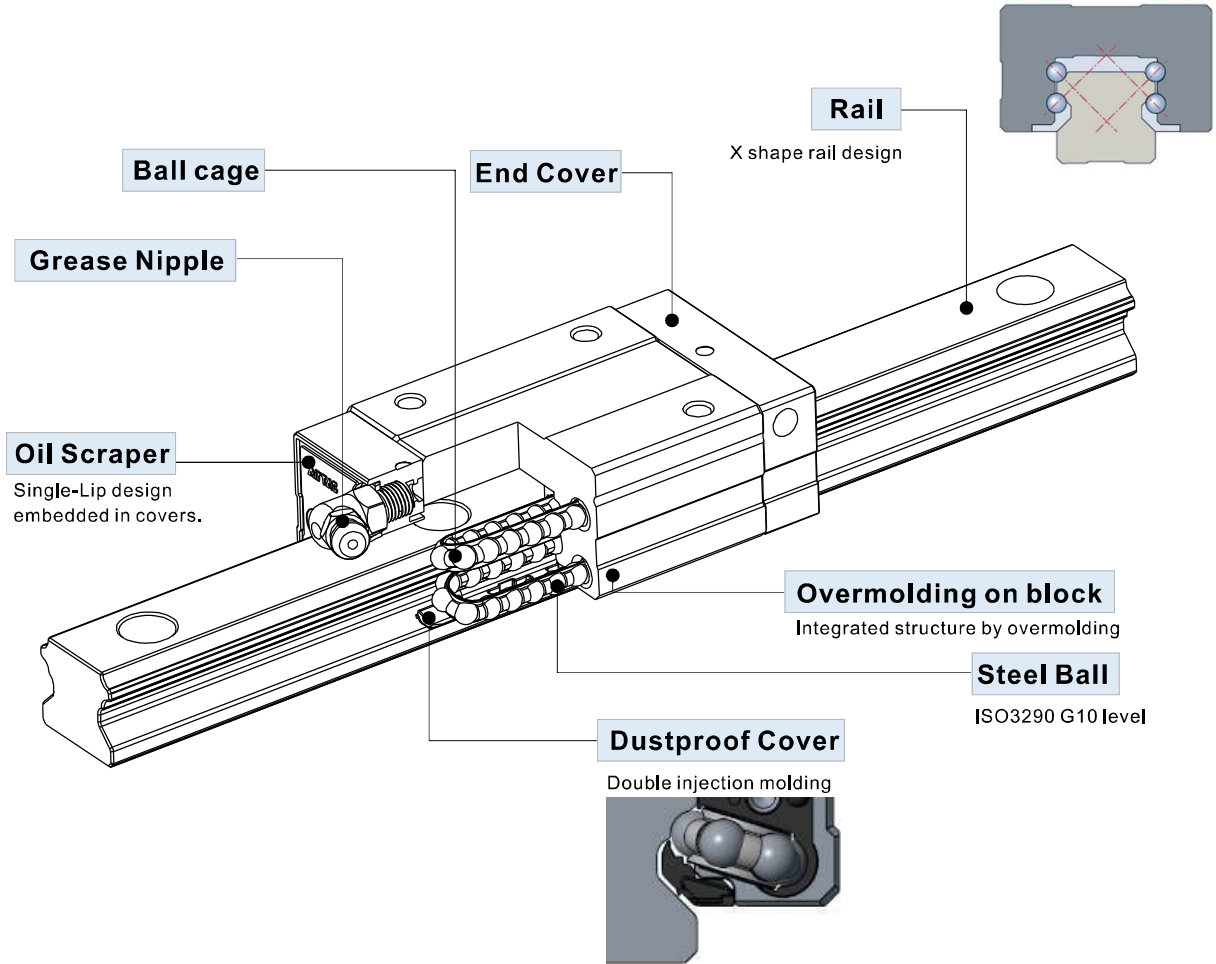

LSQH Series Caged Ball Type Linear Guide

Product Introduction



Product Features

1. Low noise design

The use of a special ball cage makes balls aligned precisely in a certain even distance, thus to eliminate noise made by random friction between balls, especially effective on high pitch noise. (details see Pic.1). According to study, human body is most sensitive to the sound between 1,000 and 3,000 Hz. After thorough lab test within allowable speed range, LSQH series can reduce noise degree by 5 dB(A) compared with LSH series. (details see Pic.2)

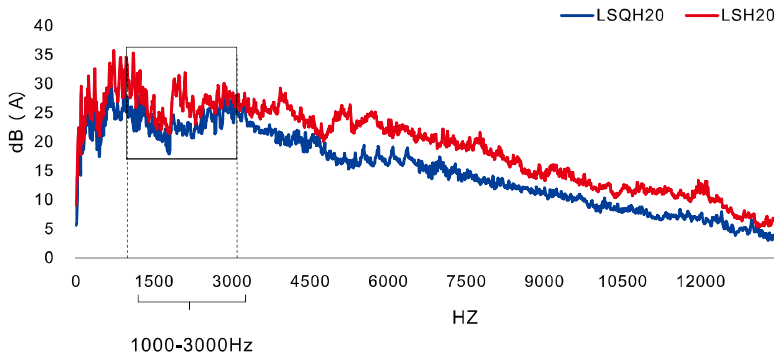

Pic.1 - Noise frequency comparison test between LSQH series and LSH series.



Pic.2 - Noise degree comparison test between LSQH series and LSH series.





LSQH Series Caged Ball Type Linear Guide

2. Self-lubricating design

Maintain designated grease storage zones at specific intervals in ball cage, precisely meeting the lubrication needs of the balls. When the circulation system operates to the direction reversal area, lubricant is automatically and evenly refilled, reducing the frequency and workload of manual grease refilling.

general ultra-light loads, no additional maintenance is required, lowering the total maintenance cost.

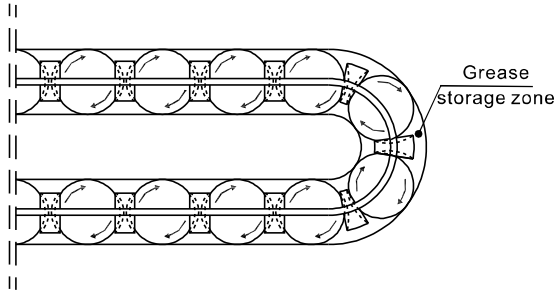

Test model	LSQH20HN1X2000S20AH-M6	Lifespan test
Speed	1 m/s	
Lubricant	Only add grease at the beginning of test (No grease supply in the middle of experiment)	
Load	4.7 KN	
Stroke	1200 KM	

3. High-velocity design

The spacer design of the ball cage eliminates friction between balls. With the balls and ball cage forming an annular line contact, friction is significantly reduced. During high-speed operation, energy loss is minimized, and heat generation is controlled, enabling the linear guide to achieve exceptional high-speed performance. This provides precise and stable linear motion guidance for high-speed mechanical systems, expanding applications in high-speed automation production lines and related fields.

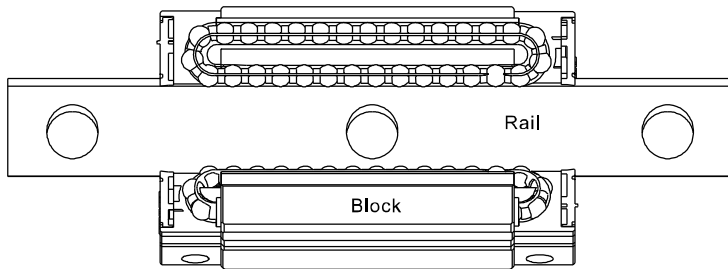

4. Improve smoothness

In traditional linear guide which is without ball cage, balls experience back-and-forth collisions during initial operation, causing severe fluctuations in friction and poor stability. The ball cage can link the balls together, allowing them to start moving almost simultaneously along with block movement, eliminating back-and-forth collisions. This maintains stable motion inertia, reduces variations in friction, ensures smooth and stable movement, and enhances fluidity and stability metrics, providing reliable support for high-precision motion control.

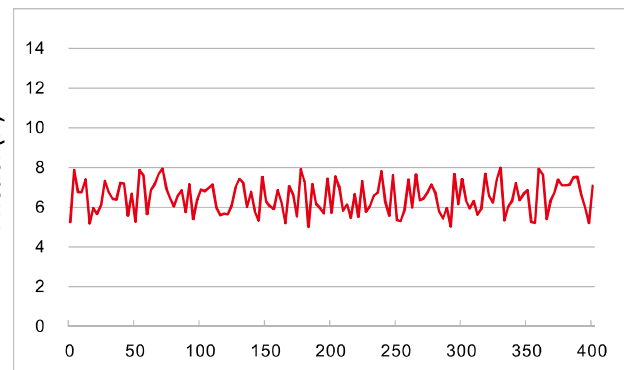
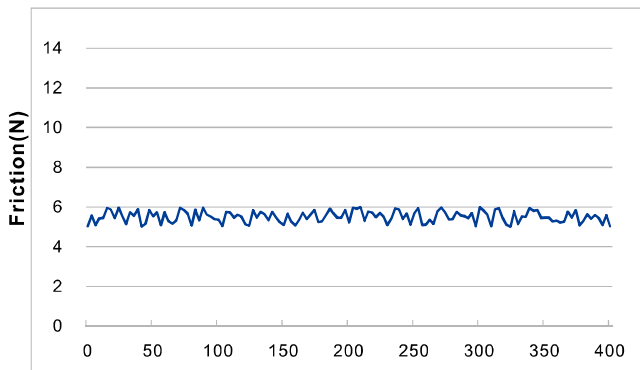

LSQH20 caged ball type (light preload) linear guide friction variation curve

LSH20 standard type (light preload) linear guide friction variation curve



Caged Ball Type Linear Guide

LSQH Series

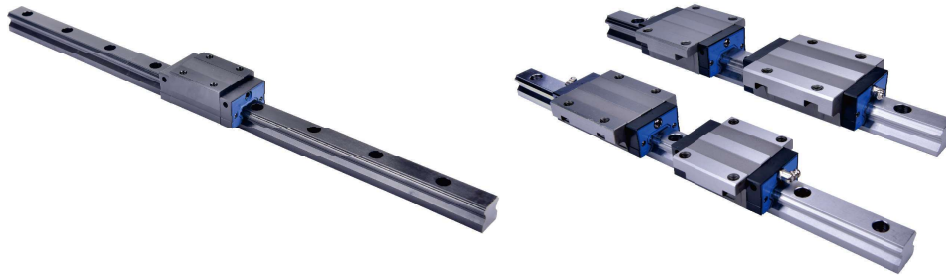

Order Information(Combined)

LSQH □ 20 H N 1 X220 S20 A H - AM8 - B - T

① ② ③ ④ ⑤ ⑥ ⑦ ⑧ ⑨ ⑩ ⑪ ⑫ ⑬

① Model Code	LSQH:Caged Ball Type Linear Guide					
② Rail&Block surface treatment	Blank: without additional coating. (natural color) ★BB: Block and rail coated with black chrome					
③ Rail Width	15: 15mm 20: 20mm 25: 23mm 30: 28mm 35: 34mm					
④ Block Style	H: Square type F1: Flange type, Mounting from top F2: Flange type, Mounting from bottom F3: Flange type, Mounting from top or bottom					
⑤ Block type	N: Standard L: Long [w/o 15 series]					
⑥ Number of Block	1: One 2: Two [Note: Amount of block on a single set of linear guide]					
⑦ Length of Rail	220:220mm[Defined by customer]					
⑧ Position of first mounting hole	S □ : Distance from end of rail to the center of first mounting hole (It is recommended to be greater than minimum margin)					
⑨ Preload	A: Standard clearance B: Light Preload C: Medium Preload D: Heavy Preload					
⑩ Accuracy	N : Normal H : High P : Precision					
⑪ Nipple /adapter type	15	M4: M4 Nipple		M6: M6 Nipple		
		AM6: M4 to M6	I type	A01: M6 to PT1/8	I type	
		LM6: M4 to M6	L type	20	AM8: M6 to M8	
				25	L01: M6 to PT1/8	L type
30	LM8: M6 to M8		35	SM6: M6 Nipple		
35						
⑫ Packing type	Blank: the block and rail are assembled B: block and rail are put separately					
⑬ Rail type	Blank: Top-mount T: Bottom-mount					

- ★ [Note 1] Self-lubricator standard type please refer to Pg. 81. for more detail.
- [Note 2] Heavy preload is available for LSQH25/30/35 only.
- [Note 3] LSQH15 only Square(H) and Flange mounting from top(F1) block styles are available.
- [Note 4] For LSQH-BB series, standard length of a rail is 3 m.
Please contact with our company if length of rail exceeds the maximum.

Caged Ball Type Linear Guide

LSQH Series

Butt-jointed Order Information

LSQH □ 20 H N 1X2970 T 2940 T 2970 A H - AM8-B - T

① ② ③ ④ ⑤ ⑥ ⑦ ⑧ ⑨ ⑩ ⑪ ⑫ ⑬ ⑭ ⑮ ⑯

Butt-jointed end margin: 1/2P ,
Position of the first and last
hole is defined by customer.

① Model Code	LSQH:Caged Ball Type Linear Guide				
② Rail&Block surface treatment	Blank: without additional coating. (natural color) ★BB: Block and rail coated with black chrome				
③ Rail Width	15: 15mm 20: 20mm 25: 23mm 30: 28mm 35: 34mm				
④ Block Style	H: Square type F1: Flange type, Mounting from top F2: Flange type, Mounting from bottom F3: Flange type, Mounting from top or bottom				
⑤ Block type	N: Standard L: Long [w/o 15 series]				
⑥ Number of Block	1: One 2: Two [Note: Amount of block on a single set of linear guide]				
⑦ Length of first Rail	2970:2970mm[Defined by customer]				
⑧ Butt-jointed mark	T: Rail Butt-jointed mark (Butt-jointed end margin: 1/2P) [P is the standard hole distance]				
⑨ Length of second Rail	2940:2940mm[Defined by customer]				
⑩ Butt-jointed mark	Blank: two rails joint T: Rail Butt-jointed mark (Butt-jointed end margin: 1/2P) [P is the standard hole distance]				
⑪ Length of third Rail	Blank: two rails joint 2970:2970mm.....[Defined by customer]				
⑫ Preload	A: Standard clearance B: Light Preload C: Medium Preload D: Heavy Preload				
⑬ Accuracy	N: Normal H: High				
⑭ Nipple /adapter type	15	M4: M4 Nipple		M6: M6 Nipple	
		AM6: M4 to M6	I type	A01: M6 to PT1/8	I type
		LM6: M4 to M6	L type	AM8: M6 to M8	
				L01: M6 to PT1/8	L type
			LM8: M6 to M8		
			SM6: M6 Nipple		
⑮ Packing type	Blank: the block and rail are assembled B: block and rail are put separately				
⑯ Rail type	Blank: Top-mount T: Bottom-mount				

★ [Note1] Self-lubricator standard type please refer to Pg. 81. for more detail.

[Note2] Number of joints cannot be more than 2 times(three rails at most).

For LSQH15/20/25, maximum length of jointed rail is 12080mm.

For LSQH30/35, it's 12030. Customization is needed for joint times more than standard.

[Note3] Heavy preload is available for LSQH25/30/35 only.

[Note4] LSQH15 only Square(H) and Flange mounting from top(F1) block styles are available.

[Note5] For LSQH-BB series, standard length of a rail is 3 m.

Maximum length of two-joint rail is 6 m.

Maximum length of three-joint rail is 9 m.

Please contact with our company

if length of rail exceeds the maximum.

Caged Ball Type Linear Guide

LSQH Series

1. Block Order Information

LSQH □ 20 BK-H N-H-D-AM8

① ② ③ ④ ⑤ ⑥ ⑦ ⑧ ⑨

① Model Code	LSQH:Caged Ball Type Linear Guide					
② Coating on block	Blank: Block without additional coating. (natural color) ★B: Block coated with black chrome					
③ Rail Width	15: 15mm 20: 20mm 25: 23mm 30: 28mm 35: 34mm					
④ Block Code	BK: Block					
⑤ Block Style	H: Square type F1: Flange type, Mounting from top F2: Flange type, Mounting from bottom F3: Flange type, Mounting from top or bottom					
⑥ Block type	N: Standard L: Long [w/o 15 series]					
⑦ Accuracy	N: Normal H: High					
⑧ Group code	SA SB SC SE SF B C D [Add]					
⑨ Nipple /adapter type	15	M4: M4 Nipple		M6: M6 Nipple		
		AM6: M4 to M6	I type	A01: M6 to PT1/8	I type	
		LM6: M4 to M6	L type	L01: M6 to PT1/8	L type	
				SM6: M6 Nipple		

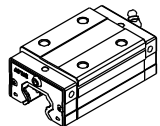

N: Standard

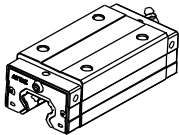

L: Long

★ [Note 1] Self-lubricator standard type please refer to Pg. 81. for more detail.

[Note 2] LSQH15 only Square(H) and Flange mounting from top(F1) block styles are available.

Add: When selecting rails and bearings, the different pairing codes can change the units preload. details see "preload pairing chart".

2. Rail Order Information

LSH 15 RL X 4000-H-E-T

① ② ③ ④ ⑤ ⑥ ⑦

① Model Code	LSH:Standard Type Linear Guide					
② Rail Width	15: 15mm 20: 20mm 25: 23mm 30: 28mm 35: 34mm					
③ Rail Code	RL: Rail					
④ Rail Length	15:4040mm 20:4040mm 25:4040mm 30:4030mm 35:4030mm					
⑤ Accuracy	N: Normal H: High					
⑥ Group code	E [Note]					
⑦ Rail type	Blank: Top-mount T: Bottom-mount					

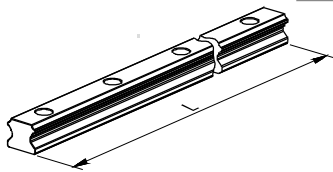

Note: ●For LSH15/20/25, both margin pitch of rail are 40mm.

●For LSH30/35, both margin pitch of rail are 55mm.

●When selecting rails and bearings, the different pairing codes can change the units preload. details see "preload pairing chart".

3. Rail Order Information

LSH □ 15 RL X 220-S20-H-E-T

① ② ③ ④ ⑤ ⑥ ⑦ ⑧ ⑨

① Model Code	LSH:Standard Type Linear Guide					
② Coating on rail	Blank: Rail without additional coating. (natural color) ★B: Rail coated with black chrome					
③ Rail Width	15: 15mm 20: 20mm 25: 23mm 30: 28mm 35: 34mm					
④ Rail Code	RL: Rail					
⑤ Rail Length	220:220mm[Defined by the customer]					
⑥ Position of first mounting hole	S□ : Distance from end of rail to the center of first mounting hole (It is recommended to be greater than minimum margin)					
⑦ Accuracy	N: Normal H: High					
⑧ Group code	E [Note]					
⑨ Rail type	Blank: Top-mount T: Bottom-mount					

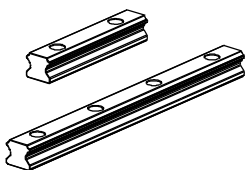

Note: 1. When selecting rails and bearings, the different pairing codes can change the units preload. details see "preload pairing chart".

2. For LSH-B series, standard length of a rail is 3 m.

Caged Ball Type Linear Guide

LSQH Series

4. Rail/Block preload pairing chart

When customer orders rail/block, please choose the pairing code of rail/block in accordance with the needed preload of linear guide(combined). Details please refer to the "preload pairing chart".

Model	Rail pairing code	Block pairing code	Preload grade	Model	Rail pairing code	Block pairing code	Preload grade
LSQH15 LSQH20	E	D	Standard clearance	LSQH25	E	D	Standard clearance
		C	Light preload			C	Light preload
		SA	Medium preload			SB	Medium preload
		SE	Heavy Preload				
LSQH30	E	D	Standard clearance	LSQH35	E	D	Standard clearance
		C	Light preload			B	Light preload
		SC	Medium preload			SC	Medium preload
		SF	Heavy Preload			SF	Heavy Preload

Accessory Order Code

L - P - AM6

① ② ③

① Accessory Code	L: Linear Guide Accessory	
② Nipple/adaptor Code	P: Nipple/adaptor	
③ Nipple/adaptor type	M4: M4 Nipple	Nipple
	AM6: M4 to M6	I type
	LM6: M4 to M6	L type
	M6: M6 Nipple	Nipple
	SM6: M6 Nipple	I type
	A01: M6 to PT1/8	I type
	AM8: M6 to M8	I type
	L01: M6 to PT1/8	L type
	LM8: M6 to M8	L type

Rail Specification

1. The maximum length of a single rail, please refer to the table for more detail about edge pitch of first mounting hole (S) and last mounting hole (E).

2. The edge pitch of first mounting hole (S) and last mounting hole (E) should not be greater than 1/2P. Overlong edge may induce unstable installation and affect the accuracy.

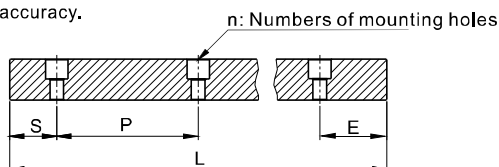

$$L = (n-1) \times P + S + E$$

L: Total length of rail(mm)

n: Numbers of mounting holes on rail

P: Distance between bolt holes(mm)

S: Edge of first mounting hole(mm)

E: Edge of last mounting hole(mm)

Model	LSH15	LSH20	LSH25	LSH30	LSH35
Pitch(P)	60	60	60	80	80
Standard Edge Pitch(S/E)	40	40	40	55	55
Min. Edge Pitch(S/E min)	5	6	7	8	8
Max. Edge Pitch(S/E max)	55	54	53	72	72
Maximum length(Lmax)	4040	4040	4040	4030	4030

Note:

- Joint rail must be chosen if length of rail exceeds the maximum.
- When deciding edge pitch, it should be within the range of above table. There would be risk of broken hole if pitch is out of range.
- Maximum length of rail for standard' means the maximum length of rail can be chosen when both sides of edge pitches are standard.

Caged Ball Type Linear Guide

LSQH Series

Specifications and Dimensions

Square type

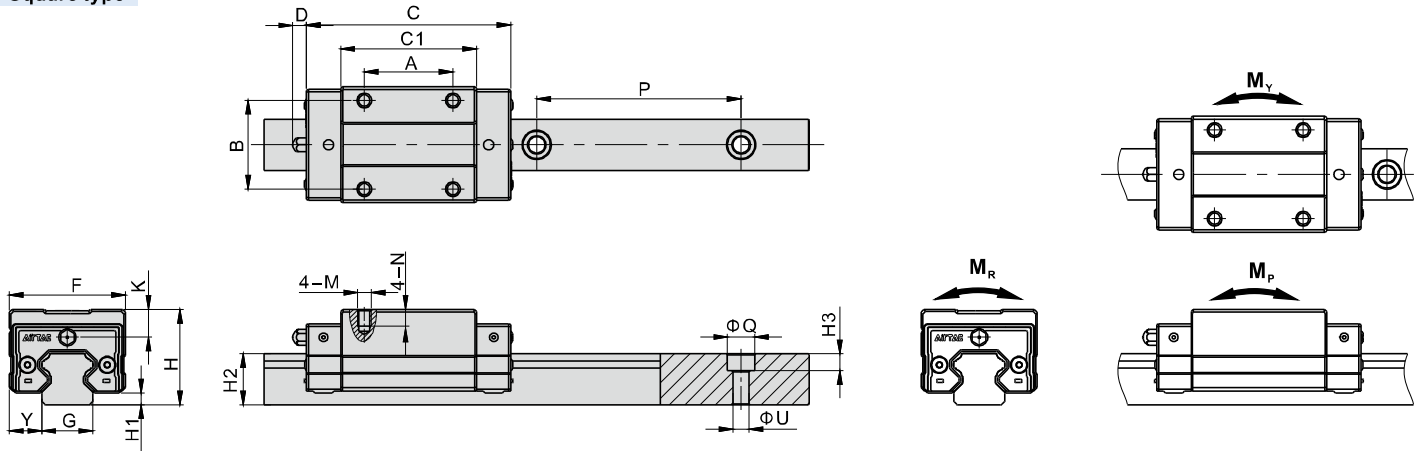

Model\Item	External Dimension (mm)				Block Dimension (mm)								Rail Dimension (mm)					
	H	H1	F	Y	C	C1	A	B	K	D	M	N	G	H2	P	ΦQ	ΦU	H3
LSQH15HN	28	3.5	34	9.5	61.5	41.5	26	26	8.3	6	M4X0.7	5	15	15	60	8	4.8	5.3
LSQH20HN	30	4.5	44	12	77	54.5	36	32	6.5	12.5	M5X0.8	5	20	17.5	60	9.5	5.8	8.5
LSQH20HL	30	4.5	44	12	92	69.5	50	32	6.5	12.5	M5X0.8	5	20	17.5	60	9.5	5.8	8.5
LSQH25HN	40	6.5	48	12.5	83.5	60	35	35	10.9	12.5	M6X1.0	8	23	22	60	11.2	7	9
LSQH25HL	40	6.5	48	12.5	104.5	81	50	35	10.9	12.5	M6X1.0	8	23	22	60	11.2	7	9
LSQH30HN	45	6.5	60	16	97.5	73	40	40	11	13	M8X1.25	10	28	26	80	14.2	9	12
LSQH30HL	45	6.5	60	16	122	97	60	40	11	13	M8X1.25	10	28	26	80	14.2	9	12
LSQH35HN	55	7	70	18	113	82	50	50	16.2	12.5	M8X1.25	12	34	29	80	14.2	9	12
LSQH35HL	55	7	70	18	140.5	109.5	72	50	16.2	12.5	M8X1.25	12	34	29	80	14.2	9	12

Model\Item	Mounting Screw	Dynamic Load Rating(kN)	Static Load Rating(kN)	Static Rated Moment (kN.m)			Weight	
		C	C ₀	M _r	M _p	M _v	Block(kg)	Rail(kg/m)
LSQH15HN	M4	13.8	14.9	0.10	0.10	0.10	0.2	1.43
LSQH20HN	M5	24.2	27.5	0.26	0.24	0.24	0.33	2.23
LSQH20HL	M5	28.9	36.4	0.34	0.33	0.33	0.41	2.23
LSQH25HN	M6	29.9	37.6	0.42	0.35	0.35	0.54	3.32
LSQH25HL	M6	36.6	47.5	0.52	0.51	0.51	0.70	3.32
LSQH30HN	M8	42.8	55.0	0.66	0.67	0.67	0.91	4.5
LSQH30HL	M8	52.3	70.0	0.84	0.87	0.87	1.17	4.5
LSQH35HN	M8	56.3	72.3	1.05	0.92	0.92	1.51	6.37
LSQH35HL	M8	58.6	92.6	1.47	1.40	1.40	1.93	6.37

Caged Ball Type Linear Guide

LSQH Series

Flange type, Top-Mount

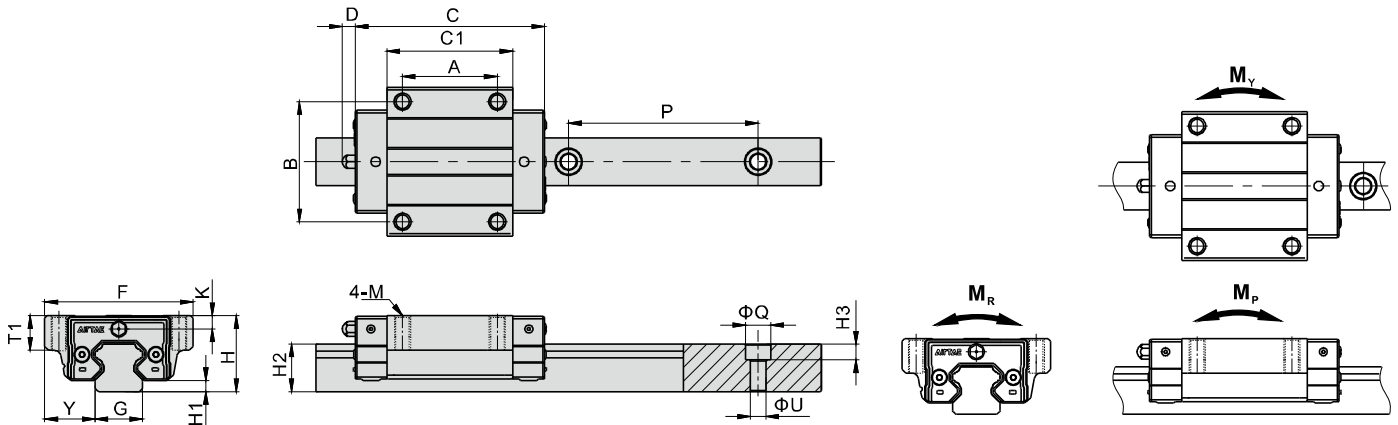

Model/Item	External Dimension (mm)				Block Dimension (mm)								Rail Dimension (mm)					
	H	H1	F	Y	C	C1	A	B	K	D	M	T1	G	H2	P	ΦQ	ΦU	H3
LSQH15F1N	24	3.5	47	16	61.5	41.5	30	38	4.3	6	M5X0.8	11	15	15	60	8	4.8	5.3
LSQH20F1N	30	4.5	63	21.5	77	54.5	40	53	6.5	12.5	M6X1.0	10	20	17.5	60	9.5	5.8	8.5
LSQH20F1L	30	4.5	63	21.5	92	69.5	40	53	6.5	12.5	M6X1.0	10	20	17.5	60	9.5	5.8	8.5
LSQH25F1N	36	6.5	70	23.5	83.5	60	45	57	6.9	12.5	M8X1.25	16	23	22	60	11.2	7	9
LSQH25F1L	36	6.5	70	23.5	104.5	81	45	57	6.9	12.5	M8X1.25	16	23	22	60	11.2	7	9
LSQH30F1N	42	6.5	90	31	97.5	73	52	72	8	13	M10X1.5	18	28	26	80	14.2	9	12
LSQH30F1L	42	6.5	90	31	122	97	52	72	8	13	M10X1.5	18	28	26	80	14.2	9	12
LSQH35F1N	48	7	100	33	113	82	62	82	9.2	12.5	M10X1.5	21	34	29	80	14.2	9	12
LSQH35F1L	48	7	100	33	140.5	109.5	62	82	9.2	12.5	M10X1.5	21	34	29	80	14.2	9	12

Model/Item	Mounting Screw	Dynamic Load Rating(kN)	Static Load Rating(kN)	Static Rated Moment (kN.m)			Weight	
		C	C ₀	M _R	M _p	M _y	Block(kg)	Rail(kg/m)
LSQH15F1N	M4	13.8	14.9	0.10	0.10	0.10	0.20	1.43
LSQH20F1N	M5	24.2	27.5	0.26	0.24	0.24	0.40	2.23
LSQH20F1L	M5	28.9	36.4	0.34	0.33	0.33	0.80	2.23
LSQH25F1N	M6	29.9	37.6	0.42	0.35	0.35	0.60	3.32
LSQH25F1L	M6	36.6	47.5	0.52	0.51	0.51	0.86	3.32
LSQH30F1N	M8	42.8	55.0	0.66	0.67	0.67	1.09	4.5
LSQH30F1L	M8	52.3	70.0	0.84	0.87	0.87	1.38	4.5
LSQH35F1N	M8	56.3	72.3	1.05	0.92	0.92	1.57	6.37
LSQH35F1L	M8	58.6	92.6	1.47	1.40	1.40	2.05	6.37

Caged Ball Type Linear Guide

LSQH Series

Flange type, Bottom-Mount

Flange type, Top or Bottom-Mount

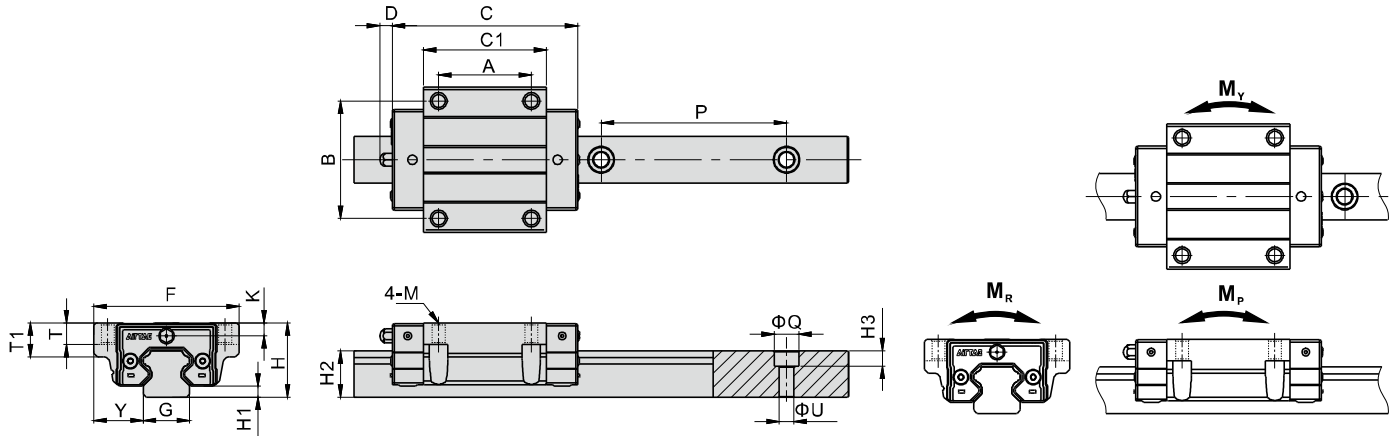

Model/Item	External Dimension(mm)				Block Dimension(mm)								Rail Dimension(mm)							
	H	H1	F	Y	C	C1	A	B	K	D	M		T	T1	G	H2	P	ΦQ	ΦU	H3
											Bottom-Mount	Top or Bottom-Mount								
LSQH20F2(F3)N	30	4.5	63	21.5	77	54.5	40	53	6.5	12.5	Φ5.7	M6X1.0	9.5	10	20	17.5	60	9.5	5.8	8.5
LSQH20F2(F3)L	30	4.5	63	21.5	92	69.5	40	53	6.5	12.5	Φ5.7	M6X1.0	9.5	10	20	17.5	60	9.5	5.8	8.5
LSQH25F2(F3)N	36	6.5	70	23.5	83.5	60	45	57	6.9	12.5	Φ6.8	M8X1.25	10	16	23	22	60	11.2	7	9
LSQH25F2(F3)L	36	6.5	70	23.5	104.5	81	45	57	6.9	12.5	Φ6.8	M8X1.25	10	16	23	22	60	11.2	7	9
LSQH30F2(F3)N	42	6.5	90	31	97.5	73	52	72	8	13	Φ9	M10X1.5	10	18	28	26	80	14.2	9	12
LSQH30F2(F3)L	42	6.5	90	31	122	97	52	72	8	13	Φ9	M10X1.5	10	18	28	26	80	14.2	9	12
LSQH35F2(F3)N	48	7	100	33	113	82	62	82	9.2	12.5	Φ9	M10X1.5	13	21	34	29	80	14.2	9	12
LSQH35F2(F3)L	48	7	100	33	140.5	109.5	62	82	9.2	12.5	Φ9	M10X1.5	13	21	34	29	80	14.2	9	12

Model/Item	Mounting Screw	Dynamic Load Rating(kN)	Static Load Rating(kN)	Static Rated Moment (kN.m)			Weight	
		C	C ₀	M _R	M _P	M _Y	Block(kg)	Rail(kg/m)
LSQH20F2(F3)N	M5	24.2	27.6	0.26	0.24	0.24	0.40	2.23
LSQH20F2(F3)L	M5	28.9	36.4	0.34	0.33	0.33	0.80	2.23
LSQH25F2(F3)N	M6	29.9	37.6	0.42	0.35	0.35	0.60	3.32
LSQH25F2(F3)L	M6	36.6	47.5	0.52	0.51	0.51	0.86	3.32
LSQH30F2(F3)N	M8	42.8	55.0	0.66	0.67	0.67	1.09	4.5
LSQH30F2(F3)L	M8	52.3	70.0	0.84	0.87	0.87	1.38	4.5
LSQH35F2(F3)N	M8	56.3	72.3	1.05	0.92	0.92	1.57	6.37
LSQH35F2(F3)L	M8	58.6	92.6	1.47	1.40	1.40	2.05	6.37

Dimension of bottom-mount type rail

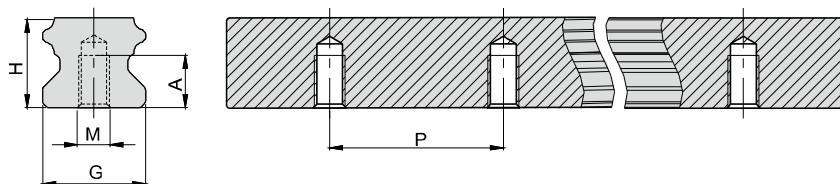

Model/Item	G	H	M	A	P
LSQH15T	15	15	M5X0.8	8	60
LSQH20T	20	17.5	M6X1.0	10	60
LSQH25T	23	22	M6X1.0	12	60
LSQH30T	28	26	M8X1.25	15	80
LSQH35T	34	29	M8X1.25	17	80

Caged Ball Type Linear Guide

LSQH Series

Accuracy

LSQH standard type linear guide comes with 3 accuracy levels.

<p>The identification line of the Datum</p>	Accuracy Standards (mm)						
	Accuracy Model	N: Normal		H: High		P: Precision	
		15/20	25/30/35	15/20	25/30/35	15/20	25/30/35
Tolerance of height H	±0.1		±0.03	±0.04	±0.015	±0.02	
Variation of height ΔH	0.02	0.025	0.01	0.015	0.006	0.007	
Tolerance of width Y	±0.1		±0.03	±0.04	±0.015	±0.02	
Variation of width ΔY	0.02	0.03	0.01	0.015	0.006	0.007	
Parallelism of C-surface relative to A-surface	Parallelism of raceway (Refer to Table 1)						
Parallelism of D-surface relative to B-surface	Parallelism of raceway (Refer to Table 1)						

Table 1 : Parallelism of the raceway

Rail Length(mm) Accuracy	Accuracy													
	100 under	100~200	200~300	300~500	500~700	700~900	900~1100	1100~1500	1500~1900	1900~2500	2500~3100	3100~3600	3600~4000	
Parallelism of the raceway(μm)	N	12	14	15	17	20	22	24	26	28	31	33	36	37
	H	7	9	10	12	13	15	16	18	20	22	25	27	28
	P	3	4	5	6	7	8	9	11	13	15	18	20	21

Preload Level

1. Preload interference

The LSQH standard type Linear Guide has three preload categories: A, B, C and D.

Choosing suitable preload level will enhance rigidity, precision and torsion resistant performance of the linear guide.

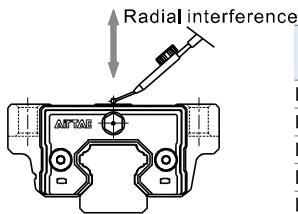

Model	Radial interference(μm)			
	Standard clearance(A)	Light Preload(B)	Medium Preload(C)	Heavy Preload(D)
LSQH15	-7~-1	-12~-4	-22~-14	-
LSQH20	-8~-1	-13~-5	-23~-15	-
LSQH25	-9~-1	-14~-6	-24~-16	-33~-25
LSQH30	-10~-1	-16~-7	-29~-20	-38~-29
LSQH35	-11~-1	-21~-11	-34~-24	-43~-33

2. Common Application

Refer to following table for suitable application of different preload grade:

Preload grade	Requirement	Common Application
Standard clearance(A)	One axial movement, small vibration and impact, accuracy requirement is low	Conveyor Machine, Semiconductor Equipment, Stage Equipment, Press Machine, Welding Machine and other light movement equipments
Light Preload(B)	Equipment that requires light-load and high-precision.	Z-axis movement for industrial use, NC lathe, EDM, Precision XY platform, Vertical machine center, measurement instrument, material feeder or industrial robot
Medium Preload(C)	Equipment that requires high rigidity, large vibration and shock.	Machining centers, NC lathes, grinders, vertical or horizontal milling machines, boring machines, tool guides, heavy cutting machines.
Heavy Preload(D)	Equipment that requires higher rigidity, larger vibration and shock.	Machining centers, NC lathes, grinders, vertical or horizontal milling machines, boring machines, tool guides, heavy cutting machines.

Caged Ball Type Linear Guide

LSQH Series

Installation Illustration

1. Allowable tolerance of mounting surface

LSQH series is an arc-shape, two-point contact design of linear guide. Its self-centering feature allows some tolerance on mounting surface without affecting the smoothness of linear motion. The allowable tolerance is indicated in following table:

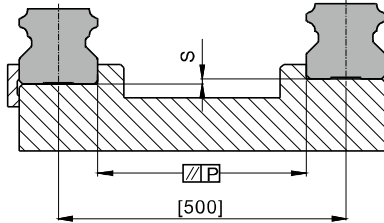

Model	Allowable tolerance of parallelism P(μm)			Allowable tolerance of top and bottom S(μm)		
	Standard clearance(A)	Light Preload(B)	Medium Preload(C)	Standard clearance(A)	Light Preload(B)	Medium Preload(C)
LSQH15	25	18	13	130	85	35
LSQH20	25	20	18	130	85	50
LSQH25	30	22	20	130	85	70
LSQH30	40	30	27	170	110	90
LSQH35	50	35	30	210	150	120

Note: The value in the table is the allowable value when the distance between the two linear guides is 500mm, and the allowable value is proportional to the distance between the two linear guides.

2. Height and Chamfer of Reference Edge

In order to ensure accurate installation of LSQH Linear Guide, the contact space should not exceed the given figures in following table.

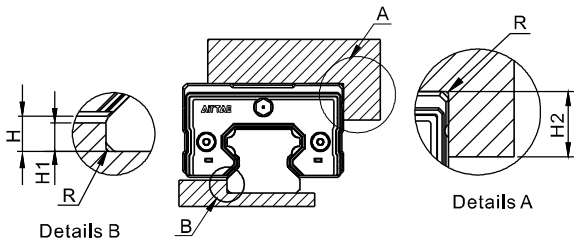

Unit : mm

Model	H	H1	H2	R(Max)
LSQH15	3.5	3	4	0.5
LSQH20	4.5	3.7	5	0.5
LSQH25	6.5	5	5	1
LSQH30	6.5	5	5	1
LSQH35	7	6	6	1

3. Screw Tighten Torque

When installing linear guide, whether the screws are well tighten and surface is well contacted will affect accuracy significantly. Please refer to following table for tightening force to ensure a perfect installation.

Model	Screw size	Tighten Torque(N.cm)		
		Iron	Casting	Aluminum alloy
LSQH15	M4	412	274	206
LSQH20	M5	882	588	441
LSQH25	M6	1370	921	686
LSQH30	M8	3040	2010	1470
LSQH35	M8	3040	2010	1470

4. Installation and Application

Linear guide installation methods can be divided into the followings. For installations other than forward installation, the lubricant may fail.

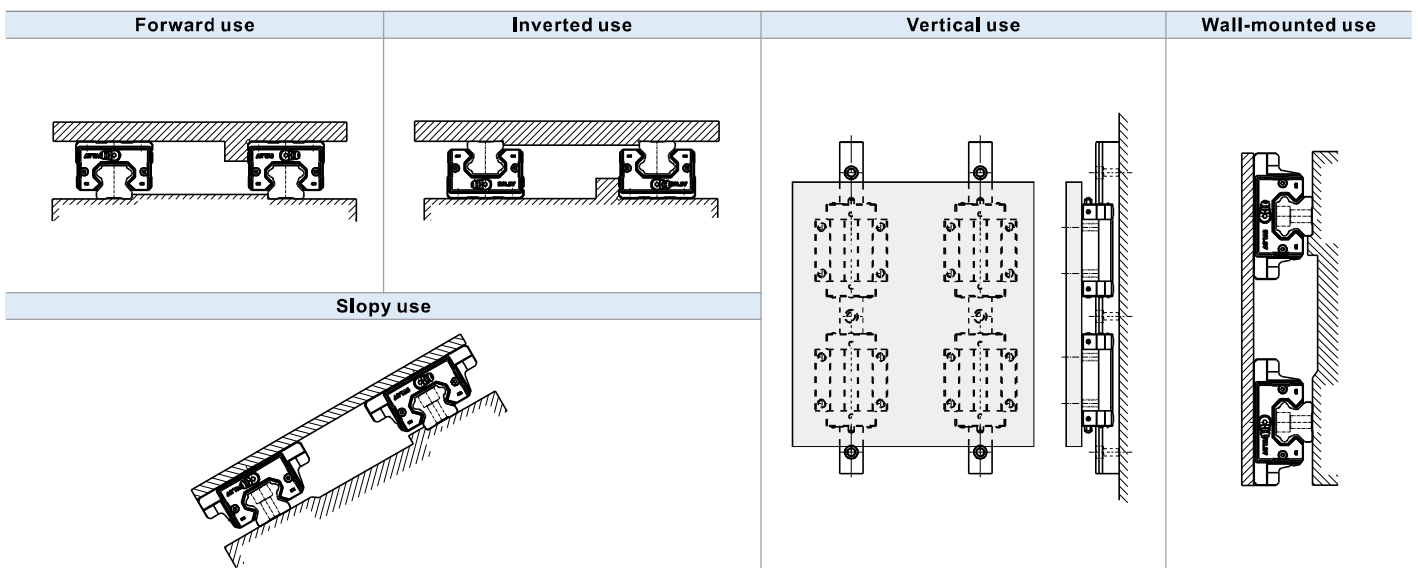

Caged Ball Type Linear Guide

LSQH Series

5. Datum plane

- Datum plane for installation must be ground or finely milled to ensure accuracy.
- Both sides of Rail can be used as the datum plane.
- For multi-blocks on a rail, identification line on blocks should be put on the same side to ensure moving accuracy.

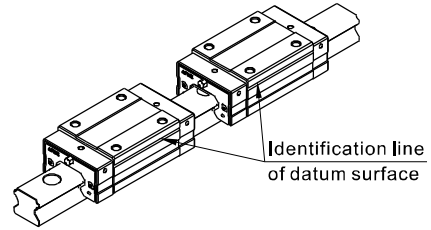

6. Fixation Method

Rails and blocks are possible to be displaced while the machine is subjected to vibrations and impacts thus to affect the accuracy. In order to avoid those difficulties and achieve high running accuracy, the following four methods are recommended for fixing.

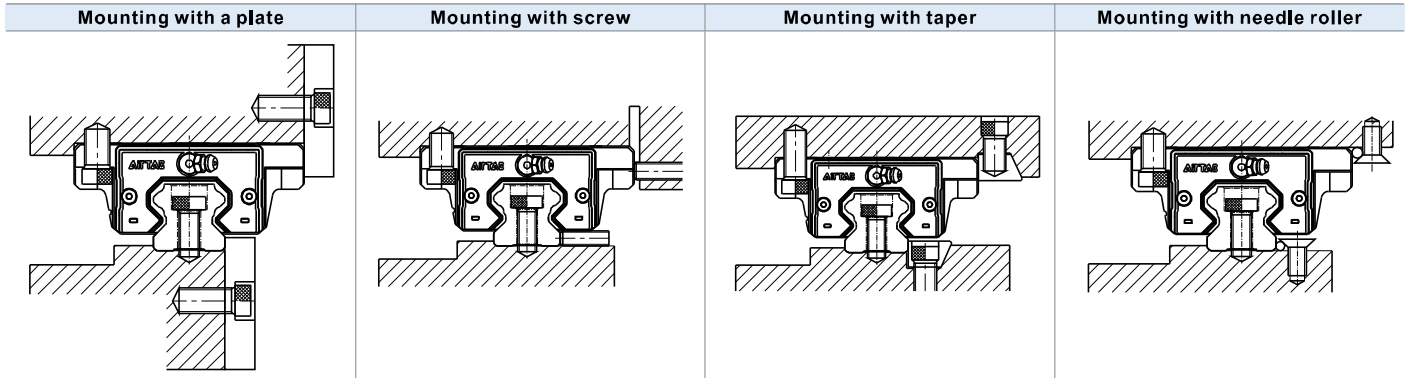

7. Rail Installation

A. Before installing the rail, remove all dirt from the mounting surface with oil stone, and then wipe with a clean cloth.

Remove all dirt from the mounting surface with oil stone, and then wipe with a clean cloth

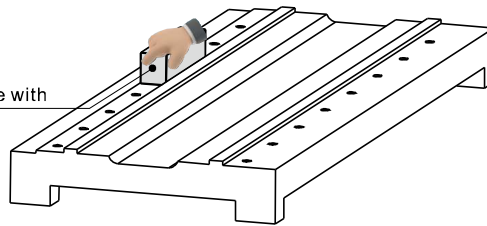

B. Place the rail gently on the bed firstly, then put the bolts into the mounting holes and pre-tighten them, place the rail ① into close contact with the datum plane of the bed by using the baffle, tighten the bolts with appropriate torque to fix the rail. Refer to "3. Screw tighten torque" for recommended torque value.

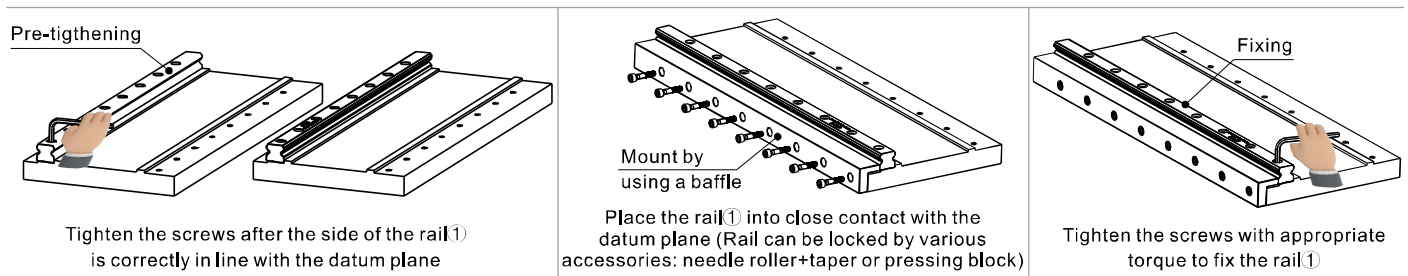

8. Block Installation

- Temporarily fix the table on the block by using the mounting bolts.
- Push the block datum plane against the side datum plane of the table and position the block by tightening the set screws.
- Tighten the mounting bolts in 1 to 4 sequences to fix the table on the block.

9. Subsidiary Rail Installation

Under the condition that the subsidiary rail has a reference datum plane, remove all dirt from the mounting surface with oil stone, and then wipe with a clean cloth, mount the subsidiary rail ② with the same method of the master rail ①.

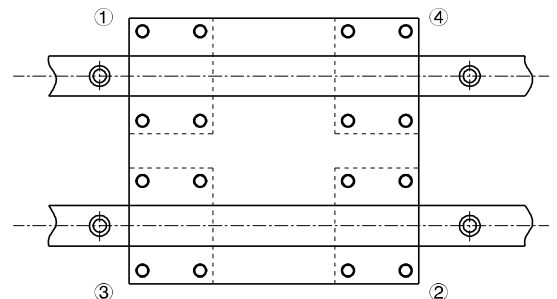
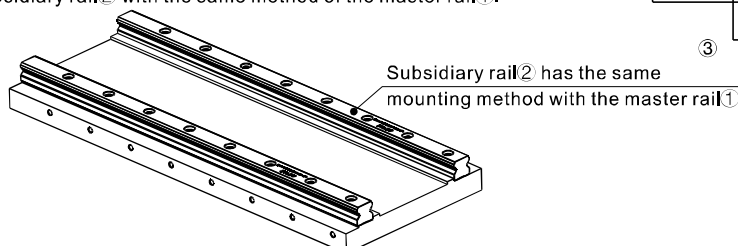

Under the condition that the subsidiary rail ② has a reference datum plane, remove all dirt from the mounting surface with oil stone, and then wipe with a clean cloth.

Caged Ball Type Linear Guide

LSQH Series

10. Rail Installation without Side Datum Surface

Using a provisional datum plane

Use the datum plane provided on the bed for straight alignment of the rail from one end to the other, attention must be paid to fix two blocks in close contact on the measuring plate.

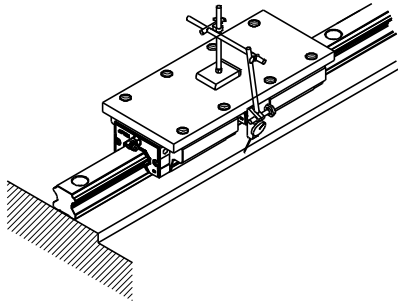

Using a straight-edge

Put the straight-edge between the two rails and use a dial gauge to adjust straight-edge in parallel with the side datum plane of the master rail. Use the dial gauge to ensure the straightness of the subsidiary rail by using the straight-edge as reference, then tighten the mounting bolts in proper sequence when the subsidiary rail is parallel to the master rail.

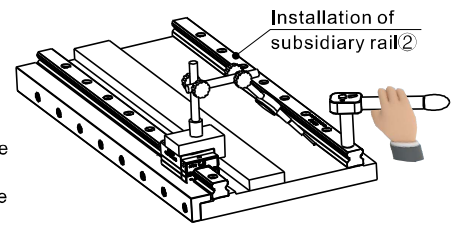

11. Rail Installation without Set Screws

To ensure parallelism between the subsidiary rail and the master rail in the condition without set screws, the following installation methods are recommended, and the installation of the block is the same as mentioned previously.

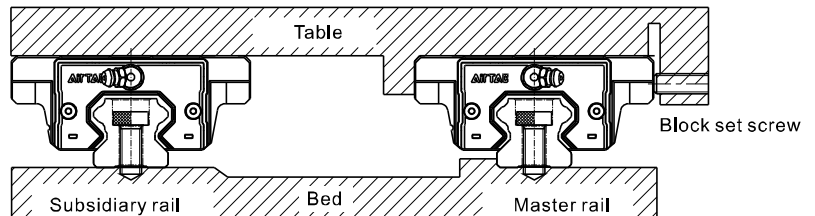

Installation of the master rail

Using a vice

Put the rail on the bed mounting surface and temporarily fasten the mounting bolts, then push the rail against the side datum plane of the bed by using a vice to ensure the rail position. Tighten the mounting bolts in proper sequence with specific torque.

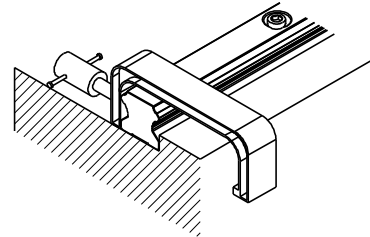

Installation of the subsidiary rail

Using a straight-edge

Put the straight-edge between the two rails and use a dial gauge to adjust straight-edge in parallel with the side datum plane of the master rail. Use the straight-edge to ensure the straightness of the subsidiary rail, then tighten the mounting bolts in proper sequence with specific torque.

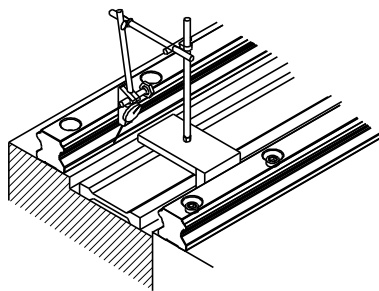

Using a table

Fix two blocks on the master rail to the table, and temporarily fix the subsidiary rail to the bed and one block on the subsidiary rail to the table. Place the gauge against the side surface of the block on the subsidiary rail, move the table from one end of the rail to the other end, then tighten the mounting bolts in proper sequence with specific torque while aligning the subsidiary rail parallel to the master rail.

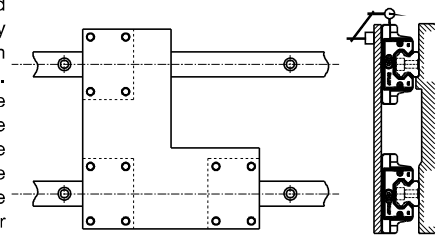

Following the master rail

Fix the table to the two blocks on the master rail and one of the two blocks on the subsidiary rail, temporarily fix the other block on the subsidiary rail to the table and subsidiary rail to the bed. Moving the table from one end of the master rail and tighten the mounting bolts on the subsidiary rail in proper sequence with specific torque at the same time.

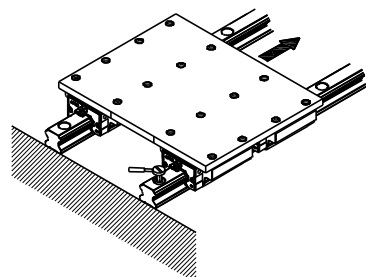

Using a jig

Use a special jig to help ensure the position of the subsidiary rail, and tighten the mounting bolts in proper sequence with specific torque.

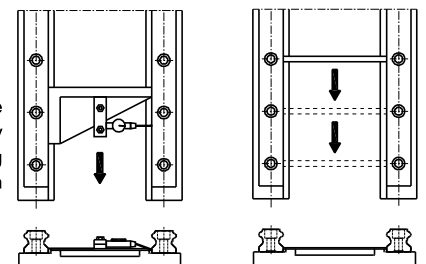

LSQH Series

12. Rail Butt-jointed

- When it comes to butt-jointed rail installation, it must follow the butt-jointed marks shown below.
- In order to avoid the accuracy caused by installing the matched jointed rails, it is recommended to stagger the butt-jointed positions, see figure below.

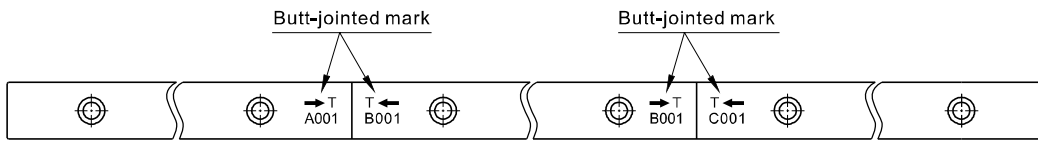

- When jointing rails, it must follow group marks on rail to ensure the accuracy of linear guide. These marks are located on the top surface at joint side. Please put the same group marks together.

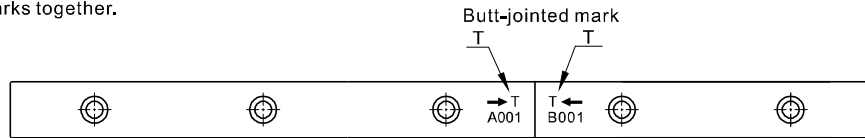

- Be aware serial number of group mark when assemble. A001 and B001 are in a group, so as to A002 and B002 and so on.
- Be aware the installation direction while assembly, the serial numbers are not upside down and arrows point to each other.

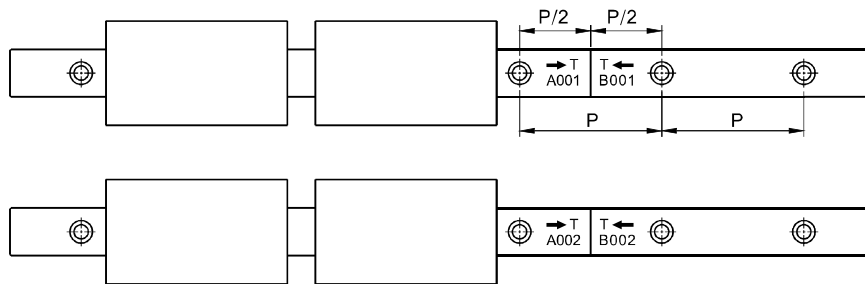

13. Measurement Method after Installation

When measuring running accuracy of the block, two blocks should be fixed on an inspection table in close contact to obtain stable accuracy. When using a dial gauge, a provisional benchmark (like a straight-edge) is recommended to put as close as possible to the block for accurate measurement.

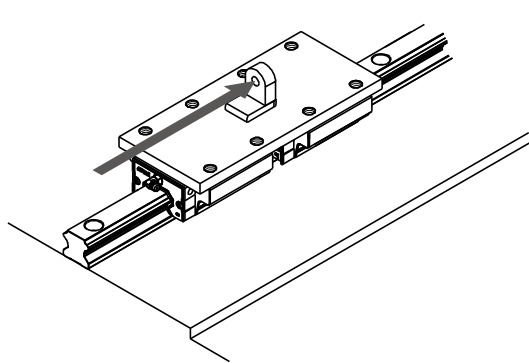

Method using an autocollimator

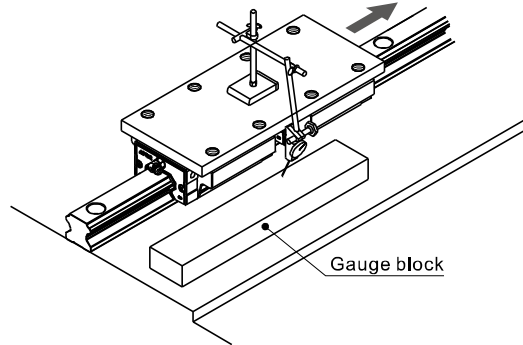

Method using a dial gauge

Caged Ball Type Linear Guide

LSQH Series

Lubrication method

When a linear guide is well lubricated, it can reduce wear and increase lifespan significantly. Lubrication has the following benefits :

- Reduces friction of the rollers and raceway to minimize wear.
- The grease film between contact surface can prevent roller fatigue.
- Prevent rust.

1. Lubrication Grease

Use the correct grade of lubrication. While lubricating, a grease gun can be used to pump grease into slider through the grease nipple on it. The suitable condition for lube is when working speed is under 60 m/min and not in cooling process.

•Nipple type

	L-P-M4	L-P-M6	L-P-SM6
Grease nipple type	<p>LSQH15</p> <p>M4X0.7P</p>	<p>LSQH20 LSQH25 LSQH30 LSQH35</p> <p>M6X0.75P</p>	<p>LSQH20 LSQH25 LSQH30 LSQH35</p> <p>M6X0.75P</p>

•Grease amount

LSQH series linear guide is well lubricated with 'Klubertplex GL261' in factory. Customers are recommended to use identical or the same grade of lubricant. After lubrication, block needs to be moved back and forth at least three times for the length of three blocks and repeat at least twice. Check if the surface of rail is well covered by grease film.

Model	Grease amount for the first lubrication(cm ³)		Replenishment amount(cm ³)	
	Standard type	Long type	Standard type	Long type
LSQH15	0.9	-	0.5	-
LSQH20	1.8	2.7	0.7	1.0
LSQH25	3.6	4.5	1.4	1.7
LSQH30	5.4	7.2	2.2	2.7
LSQH35	8.1	10	3.3	3.8

•Lubrication frequency

Although the linear guides are well lubricated at the factory and retains grease well, frequent lubrication is still necessary to avoid undesirable wear. Recommended lubrication period is every 100km of movement or every 3~6 months. (Refer to table on the top for suggested amount)

2. Lubricating oil

Recommended oil viscosity for lubrication use is about 30 to 150 cst.

Lubrication oil is suitable for all kinds of load and impact application, but not for high temperature use due to its tendency of vaporization.

•Adaptor

L-P-AM6	L-P-AM8	L-P-A01
<p>LSQH15</p>	<p>LSQH35 LSQH30 LSQH25 LSQH20</p>	<p>LSQH35 LSQH30 LSQH25 LSQH20</p>
L-P-LM6	L-P-LM8	L-P-L01
<p>LSQH15</p>	<p>LSQH35 LSQH30 LSQH25 LSQH20</p>	<p>LSQH35 LSQH30 LSQH25 LSQH20</p>

LSQH Series

Lubrication method

•Oil supply rate

Loss of lubrication oil is faster than lubrication grease. Pay attention to sufficiency of oil while using.

Model	Oil amount for the first lubrication(cm ³)	Feeding Speed(cm ³ /hr)
LSQH15	0.6	0.2
LSQH20	0.6	0.2
LSQH25	0.9	0.3
LSQH30	0.9	0.3
LSQH35	0.9	0.3

3. Grease nipple/adaptor installation

- Grease nipple or adaptor can be installed in the two sides of block for manual or automatic lubrication based on customer's requirement.
- There are a secondary set of lubricating ports on the side of the block. When using, it is not recommended to use the side with datum line unless necessary.
- Lateral nipple installation is not recommended for flange type blocks.
(The grease / oil nipple may interfere with block)
- If lateral lubrication is needed for above spec, please contact us for customization.

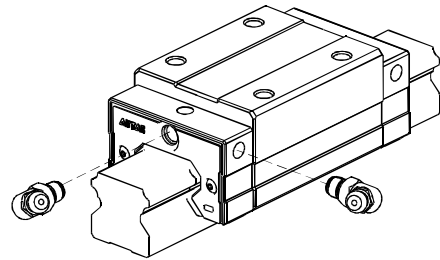

Bolt hole plug

1. Plug type

In order to prevent metal swarf or external objects from entering blocks and affecting precision and lifespan, customers must put plugs into holes during installation. Every rail is equipped with default plugs.

Model	Bolt	Diameter(D)(mm)	Thickness(H)(mm)
LSH15	M4	8.15	1.1
LSH20	M5	9.65	2.5
LSH25	M6	11.4	2.5
LSH30	M8	14.4	3.5
LSH35	M8	14.4	3.5

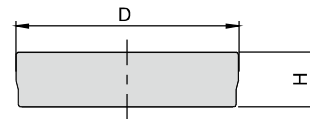

2. Plug installation Steps

Step one

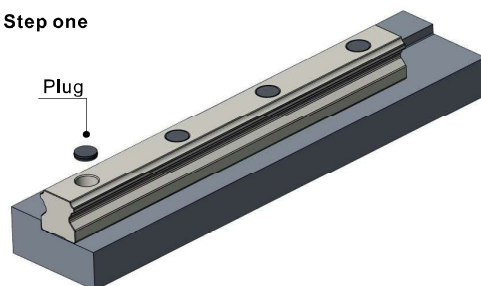

Place the plug in counterbore.

Note :

- Please make sure the plugs do not protrude the rail surface.
- After installation, please clean the surface before use.

Step two

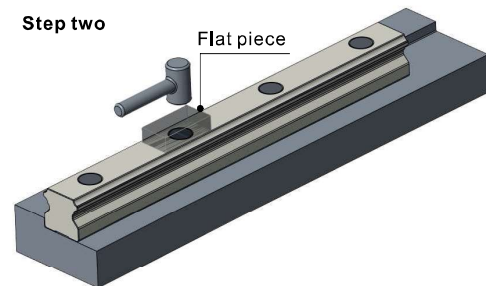

Place the flat piece on mounting hole, hit the piece vertically with a plastic hammer and fix the plug into counterbore.

Self-lubricator Standard Linear Guide



LSQH Series



Order Information(Combined)

LSQH □ 20 H N 1 X220 S20 AH-AM8 - B-T-E

① ② ③ ④ ⑤ ⑥ ⑦ ⑧ ⑨ ⑩ ⑪ ⑫ ⑬ ⑭

① Model Code	LSQH:Self-lubricator Standard Linear Guide		
② Rail&Block surface treatment	Blank: without additional coating. (natural color) ★BB: Block and rail coated with black chrome		
③ Rail Width	15: 15mm	20: 20mm	25: 23mm 30: 28mm 35: 34mm
④ Block Style	H: Square type F1: Flange type, Mounting from top F2: Flange type, Mounting from bottom F3: Flange type, Mounting from top or bottom		
⑤ Block type	N: Standard L: Long [w/o 15 series]		
⑥ Number of Block	1: One	2: Two [Note: Amount of block on a single set of linear guide]	
⑦ Length of Rail	220:220mm[Defined by customer]		
⑧ Position of first mounting hole	S□ : Distance from end of rail to the center of first mounting hole (It is recommended to be greater than minimum margin)		
⑨ Preload	A: Standard clearance	B: Light Preload	C: Medium Preload D: Heavy Preload
⑩ Accuracy	N : Normal H : High P : Precision		
⑪ Nipple /adapter type	M4: M4 Nipple		
	AM6: M4 to M6	I type 	20
	LM6: M4 to M6	L type 	25
			30
			35
			M6: M6 Nipple
			A01: M6 to PT1/8 I type
			AM8: M6 to M8
			L01: M6 to PT1/8 L type
			LM8: M6 to M8
			SM6: M6 Nipple
⑫ Packing type	Blank: the block and rail are assembled B: block and rail are put separately		
⑬ Rail type	Blank: Top-mount T: Bottom-mount		
⑭ Self-lubricator Standard Type	E: Self-lubricator Standard Type		

[Note 1] Heavy preload is available for LSQH25/30/35 only.

[Note 2] LSQH15 only Square(H) and Flange mounting from top(F1) block styles are available.

[Note 3] For LSQH-BB series, standard length of a rail is 3 m.

Please contact with our company if length of rail exceeds the maximum.



Self-lubricator Standard Linear Guide









LSQH Series

Butt-jointed Order Information

LSQH □ 20 H N 1X2970T2940T2970 A H – AM8-B – T – E

① ② ③ ④ ⑤ ⑥ ⑦ ⑧ ⑨ ⑩ ⑪ ⑫ ⑬ ⑭ ⑮ ⑯ ⑰

Butt-jointed end margin: 1/2P ,
Position of the first and last
hole is defined by customer.

① Model Code	LSQH:Self-lubricator Standard Linear Guide	
② Rail&Block surface treatment	Blank: without additional coating. (natural color) ★BB: Block and rail coated with black chrome	
③ Rail Width	15: 15mm 20: 20mm 25: 23mm 30: 28mm 35: 34mm	
④ Block Style	H: Square type F1: Flange type, Mounting from top F2: Flange type, Mounting from bottom F3: Flange type, Mounting from top or bottom	
⑤ Block type	N: Standard L: Long [w/o 15 series]	
⑥ Number of Block	1: One 2: Two [Note: Amount of block on a single set of linear guide]	
⑦ Length of first Rail	2970:2970mm[Defined by customer]	
⑧ Butt-jointed mark	T: Rail Butt-jointed mark (Butt-jointed end margin: 1/2P) [P is the standard hole distance]	
⑨ Length of second Rail	2940:2940mm[Defined by customer]	
⑩ Butt-jointed mark	Blank: two rails joint T: Rail Butt-jointed mark (Butt-jointed end margin: 1/2P) [P is the standard hole distance]	
⑪ Length of third Rail	Blank: two rails joint 2970:2970mm.....[Defined by customer]	
⑫ Preload	A: Standard clearance B: Light Preload C: Medium Preload D: Heavy Preload	
⑬ Accuracy	N : Normal H : High	
⑭ Nipple /adapter type	M4: M4 Nipple	
	AM6: M4 to M6	I type 
	LM6: M4 to M6	L type 
	M6: M6 Nipple	
	A01: M6 to PT1/8	I type 
	AM8: M6 to M8	L type 
L01: M6 to PT1/8		
LM8: M6 to M8		
SM6: M6 Nipple		
⑮ Packing type	Blank: the block and rail are assembled B: block and rail are put separately	
⑯ Rail type	Blank: Top-mount T: Bottom-mount	
⑰ Self-lubricator Standard Type	E: Self-lubricator Standard Type	

[Note1] Number of joints cannot be more than 2 times(three rails at most).

For LSQH15/20/25, maximum length of jointed rail is 12080mm.

For LSQH30/35, it's 12030. Customization is needed for joint times more than standard.

[Note2] Heavy preload is available for LSQH25/30/35 only.

[Note3]LSQH15 only Square(H) and Flange mounting from top(F1) block styles are available.

[Note4] For LSQH-BB series, standard length of a rail is 3 m.

Maximum length of two-joint rail is 6 m. Maximum length of three-joint rail is 9 m.

Please contact with our company if length of rail exceeds the maximum.

Self-lubricator Standard Linear Guide

LSQH Series

1. Block Order Information

LSQH □ 20 BK- H N - H - D - AM8- E

① ② ③ ④ ⑤ ⑥ ⑦ ⑧ ⑨ ⑩

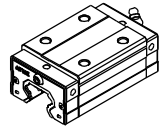

N: Standard

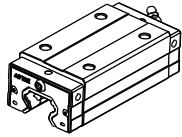

L: Long

① Model Code	LSQH: Self-lubricator Standard Linear Guide					
② Coating on block	Blank: Block without additional coating. (natural color) ★B: Block coated with black chrome					
③ Rail Width	15: 15mm 20: 20mm 25: 23mm 30: 28mm 35: 34mm					
④ Block Code	BK: Block					
⑤ Block Style	H: Square type F1: Flange type, Mounting from top F2: Flange type, Mounting from bottom F3: Flange type, Mounting from top or bottom					
⑥ Block type	N: Standard L: Long [w/o 15 series]					
⑦ Accuracy	N: Normal H: High					
⑧ Group code	SA SB SC SE SF B C D [Note1]					
⑨ Nipple /adapter type	15	M4: M4 Nipple		20 25 30 35	M6: M6 Nipple	
		AM6: M4 to M6	I type		A01: M6 to PT1/8	I type
		LM6: M4 to M6	L type		L01: M6 to PT1/8	L type
					LM8: M6 to M8	
					SM6: M6 Nipple	
⑩ Self-lubricator Standard Type	E: Self-lubricator Standard Type					

[Note1]: When selecting rails and bearings, the different pairing codes can change the units preload. details see "preload pairing chart".

[Note 2] LSQH15 only Square(H) and Flange mounting from top(F1) block styles are available.

LSQH Series

Self-lubricator illustration

1. Code and structure

AirTAC provides self-lubricator for applications e.g. limited spaces, or where grease maintenance is challenging.

If needed, please add the code "E" after the product model.

E.g. LSQH20HN1X220S20AH-AM8 - B - T - E

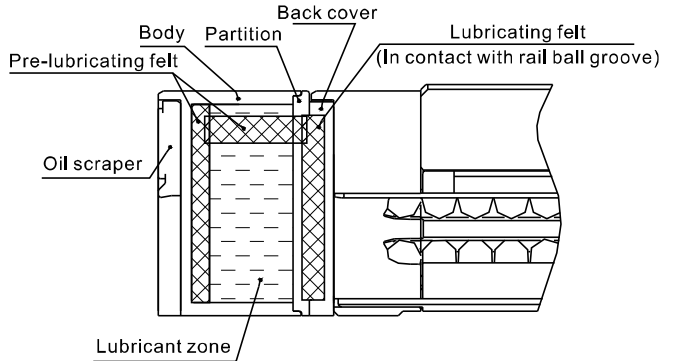
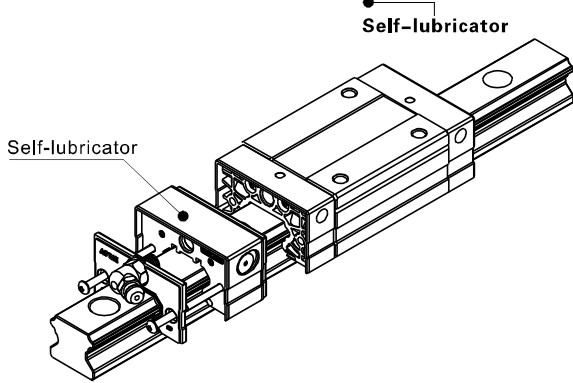

Product Features

- Easy Maintenance and Long-Term Maintenance-Free Operation:** In normal applications, basically no additional grease maintenance is required throughout lifespan of linear guide.
 - Cost Savings:** No additional lubrication is needed for the block, reducing labor and material costs.
 - Flexible Use in Specific Environments:** Equipped with a high-capacity grease tank, allowing the use of specific lubricants for specific environments.
 - Dustproof Design:** Built-in dustproof structure extends lifespan.
 - Flexible in usage and installation:** the assembling and disassembling of self-lubricator in integrity structure is convenient, can have it according to different working condition.
- [Note] Self-lubricator type block is not applicable for ultra-smooth application, as the higher viscosity of the lubricant in self-lubricator will increase friction by approximately 5–7N.

Durability test of self-lubricator

Test specification	Test specification	Model	Speed	Stroke	Lubricant type
■	Lubricating effect	LSQH20	30m/min	1200mm	ISO VG680 high-quality extreme pressure lubricant

■ Test result

Test result shows that after running 1,000 km, only 20% of the grease is consumed, and the linear guide remains lubricated. The expected service life can possibly exceed 4,000 km.

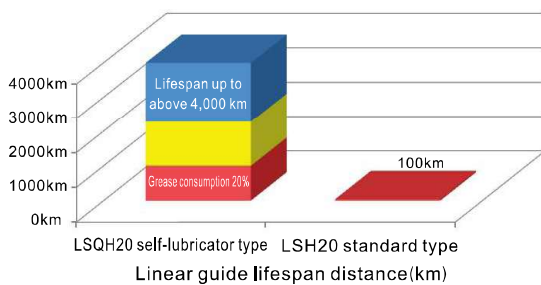

When comparing each sub-series with the self-lubricator and the standard model, the length of block will change. Please refer to the table below for details.

- Block dimension comparison (only dimension C is different from the standard, the rest remains the same)

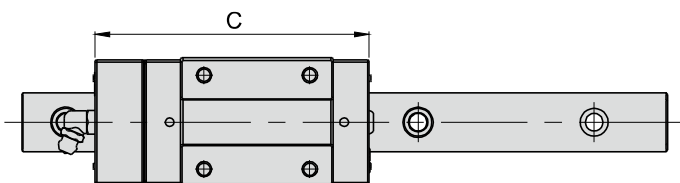

Model	Type	Length C(mm)	
		Standard (Blank)	Self-lubricator Standard Type
LSQH15□N	Standard	61.5	77
LSQH20□N	Standard	77	94
LSQH20□L	Long	92	109
LSQH25□N	Standard	83.5	100.5
LSQH25□L	Long	104.5	121.5
LSQH30□N	Standard	97.5	114.5
LSQH30□L	Long	122	139
LSQH35□N	Standard	113	130
LSQH35□L	Long	140.5	157.5

Precautions on use

1. Block disassembly

With ball retainers and a dustproof cover, normally the balls are prevented from falling out when block is removed from rail. However, if obliquely insert rail into blocks or quickly assembled or disassembled, there is a risk for balls of falling out. Please carefully assemble the linear guide or use plastic rails to assist.

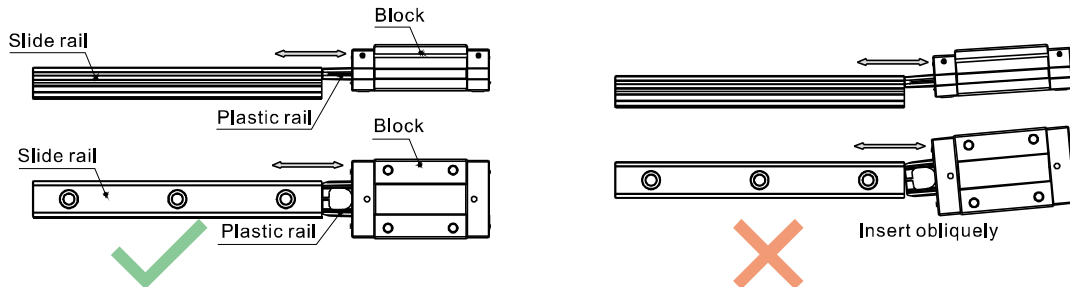

2. Plastic rail installation

A plastic rail is equipped for individual block set. Please do not remove plastic rail whenever it is not necessary.

If plastic rail falls out and needs to be reinstalled, press the dustproof covers with fingers and install slowly to prevent balls from falling out due to misalignment of plastic rail.

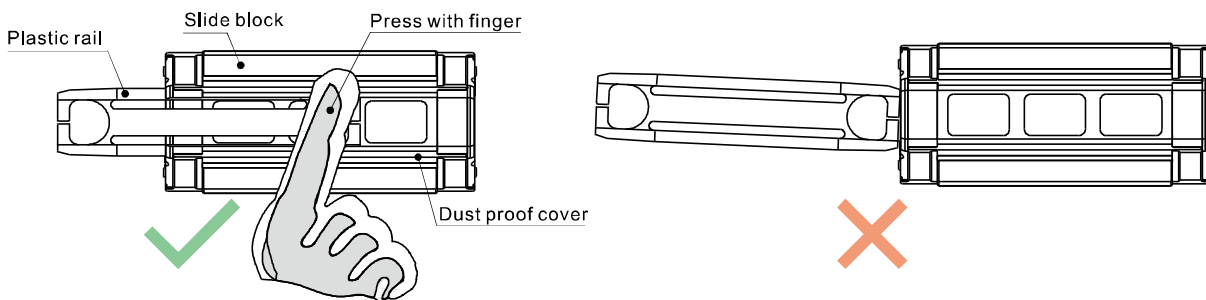

Press the dust-proof covers and insert plastic rail in alignment.

Without pressing dust-proof covers or insert plastic rail obliquely.

3. Caution

- Parts may slide out if linear guide is put unevenly. Please be careful.
- Hitting or dropping linear guide could have huge effect on accuracy and lifespan even though appearance may remain intact. Please be careful.
- Do not disassemble linear guide as external objects may enter blocks and cause accuracy problem.

4. Lubrication

- Linear guide have been treated with anti-rust oil during production. Before use, wipe the rail and treat it with lubrication.
- Do not mix lubricating oil (grease) with different properties.
- After lubrication, move block back and forth for the length of three blocks long and repeat at least 2 times to ensure there is a grease file on rail.

5. Use

- The operating environment temperature should not exceed 80°C, and the maximum temperature should not exceed 100°C.
- Do not separate blocks from rail whenever it is not necessary. If you need to separate them, please use plastic rails to prevent steel balls from falling out.

6. Storage

- When storing blocks, rails or linear guide set, please be sure that anti-rust oil is well applied and product is well sealed as well as placed horizontally. Avoid humidity and high temperatures environment.



BIBUS
SUPPORTING YOUR SUCCESS

BIBUS SK, s.r.o
Trnavská 31, SK-94 901 Nitra

Tel.: 0371 7777 911 Email: sale@bibus.sk
Fax.: 0371 7777 999 http://www.bibus.sk