

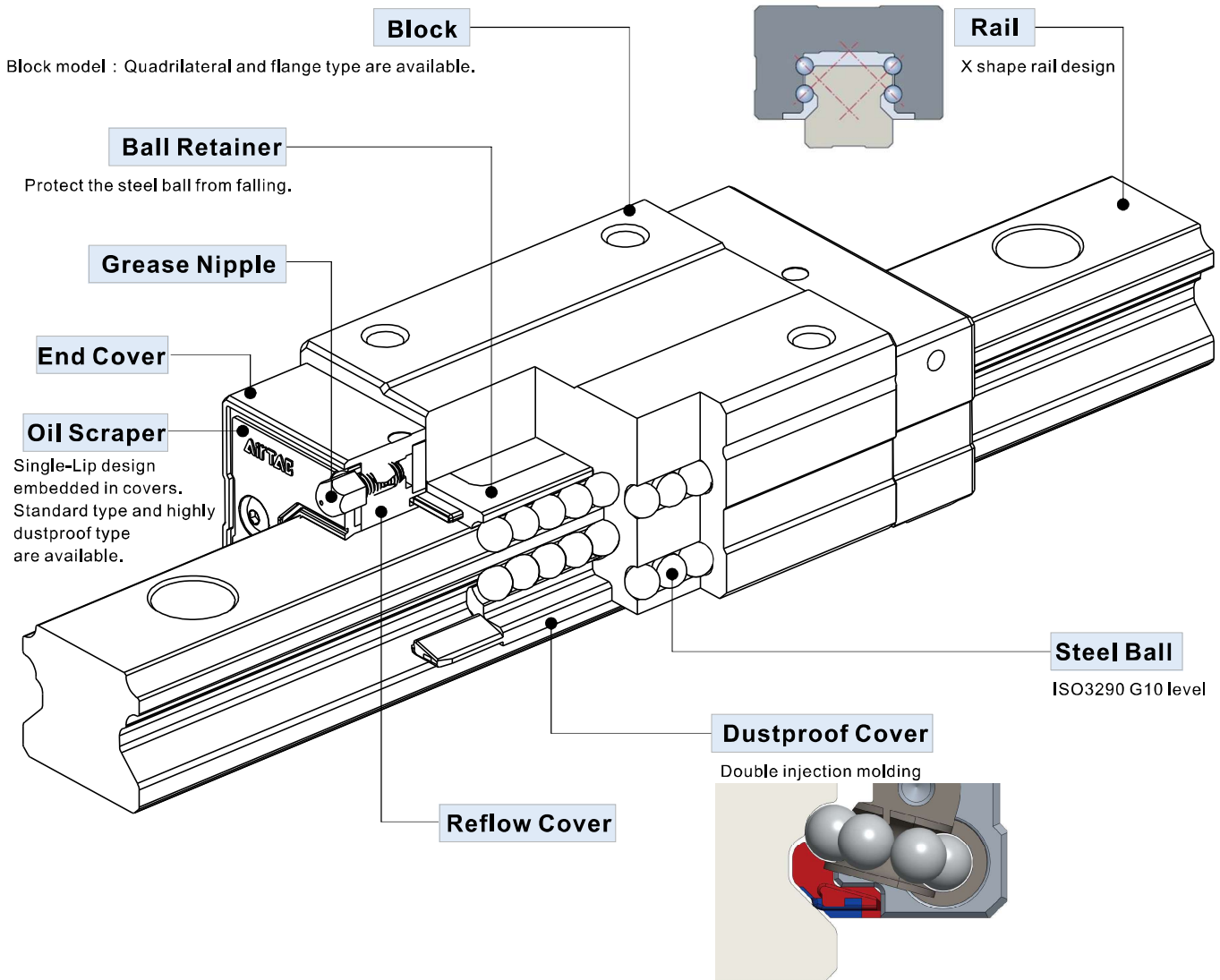

# LSH Series Standard Type Linear Guide

## Product Introduction



## Product Features

### 1. With self-adjustment ability

X-shaped ( $45^{\circ}$ - $45^{\circ}$ ) of curved groove on cross section design makes it self-aligning. Even small misalignment exists on the mounting surface, this design can help absorb it and maintain high precision, smooth and stable linear motion.

### 2. High rigidity, equal load on four direction design

The 45-degree contact angle design of the four rows of steel balls and the raceway allow the steel balls to achieve the ideal two-point contact, and can withstand the action and reaction force from the radial and lateral direction. Meanwhile, pre-load can be applied to increase extra rigidity if necessary.

### 3. Interchangeable

Because of the strict control on manufacturing process, the dimensional accuracy is stable and within the set tolerance. Besides the ball retainer design can prevent steel balls from falling out. Therefore when assembling, blocks are interchangeable within the same spec and still maintain consistency of pre-load and accuracy.



# Standard Type Linear Guide



## LSH Series



### Order Information(Combined)

LSH □ 15 H N 1 X220 S20 A H - AM6 - B - T

① ② ③ ④ ⑤ ⑥ ⑦ ⑧ ⑨ ⑩ ⑪ ⑫ ⑬

① Model Code	LSH: Standard Type Linear Guide		
② Rail & Block surface treatment	Blank: without additional coating. (natural color) ★BB : Block and rail coated with black chrome		
③ Rail Width	15: 15mm	20: 20mm	25: 23mm 30: 28mm 35: 34mm 45: 45mm
④ Block Style	H: Square type      F1: Flange type, Mounting from top F2: Flange type, Mounting from bottom F3: Flange type, Mounting from top or bottom		
⑤ Block type	N: Standard    L: Long [w/o 15 series]		
⑥ Number of Block	1: One    2: Two [Note: Amount of block on a single set of linear guide]		
⑦ Length of Rail	220: 220mm ..... [Defined by customer]		
⑧ Position of first mounting hole	S□ : Distance from end of rail to the center of first mounting hole (It is recommended to be greater than minimum margin)		
⑨ Preload	A: Standard clearance    B: Light Preload    C: Medium Preload    D: Heavy Preload		
⑩ Accuracy	N : Normal    H : High    P : Precision		
⑪ Nipple / adapter type	M4: M4 Nipple	M6: M6 Nipple	P01: PT1/8 Nipple
	AM6: M4 to M6	A01: M6 to PT1/8	A01: PT1/8 to PT1/8
	LM6: M4 to M6	AM8: M6 to M8	AM8: PT1/8 to M8
		L01: M6 to PT1/8	L01: PT1/8 to PT1/8
		LM8: M6 to M8	LM8: PT1/8 to M8
		SM6: M6 Nipple	SP01: PT1/8 Nipple
⑫ Packing type	Blank: the block and rail are assembled B: block and rail are put separately		
⑬ Rail type	Blank: Top-mount    T: Bottom-mount		

★ [Note 1] Dustproof standard type please refer to Pg. 26. for more detail.

★ [Note 2] Self-lubricator standard type please refer to Pg. 30. for more detail.

[Note 3] For LSH-BB series, standard length of a rail is 3 m.

Please contact with our company if length of rail exceeds the maximum.

Add: Heavy preload is available for LSH25/30/35/45 only.



# Standard Type Linear Guide

## LSH Series

### Butt-jointed Order Information

LSH □ 15 H N 1X2970 T 2940 T 2970 A H - AM6-B - T



Butt-jointed end margin: 1/2P ,  
Position of the first and last  
hole is defined by customer.

① Model Code	LSH: Standard Type Linear Guide		
② Rail&Block surface treatment	Blank: without additional coating. (natural color) ★BB : Block and rail coated with black chrome		
③ Rail Width	15: 15mm 20: 20mm 25: 23mm 30: 28mm 35: 34mm 45: 45mm		
④ Block Style	H: Square type F1: Flange type, Mounting from top F2: Flange type, Mounting from bottom F3: Flange type, Mounting from top or bottom		
⑤ Block type	N: Standard L: Long [w/o 15 series]		
⑥ Number of Block	1: One 2: Two [Note: Amount of block on a single set of linear guide]		
⑦ Length of first Rail	2970:2970mm .....[Defined by customer]		
⑧ Butt-jointed mark	T: Rail Butt-jointed mark (Butt-jointed end margin: 1/2P) [P is the standard hole distance]		
⑨ Length of second Rail	2940:2940mm .....[Defined by customer]		
⑩ Butt-jointed mark	Blank: two rails joint T: Rail Butt-jointed mark (Butt-jointed end margin: 1/2P) [P is the standard hole distance]		
⑪ Length of third Rail	Blank: two rails joint 2970:2970mm.....[Defined by customer]		
⑫ Preload	A: Standard clearance B: Light Preload C: Medium Preload D: Heavy Preload		
⑬ Accuracy	N : Normal H : High		
⑭ Nipple /adapter type	M4: M4 Nipple	M6: M6 Nipple	P01: PT1/8 Nipple
	AM6: M4 to M6 I type	A01: M6 to PT1/8 I type	A01: PT1/8 to PT1/8 I type
	20 25 30 35 LM6: M4 to M6 L type	20 25 30 35 L01: M6 to PT1/8 L type	45 LM8: PT1/8 to M8 L type
	LM6: M4 to M6	LM8: M6 to M8	SM6: M6 Nipple
⑮ Packing type	Blank: the block and rail are assembled B: block and rail are put separately		
⑯ Rail type	Blank: Top-mount T: Bottom-mount		

- ★ [Note 1] Dustproof standard type please refer to Pg. 26. for more detail.
- ★ [Note 2] Self-lubricator standard type please refer to Pg. 30. for more detail.

[Note 3] For LSH-BB series, standard length of a rail is 3 m.

Maximum length of two-joint rail is 6 m.  
Maximum length of three-joint rail is 9 m.  
Please contact with our company  
if length of rail exceeds the maximum.

Add1: Number of joints cannot be more than 2 times (three rails at most).

For LSH15/20/25, maximum length of jointed rail is 12080mm.

For LSH30/35, it's 12030. For LSH45, it's 12000.

Customization is needed for joint times more than standard.

Add2: Heavy preload is available for LSH25/30/35/45 only.

# Standard Type Linear Guide

## LSH Series

### 1. Block Order Information

LSH □ 15 BK-H N-H-E-AM6

① ② ③ ④ ⑤ ⑥ ⑦ ⑧ ⑨

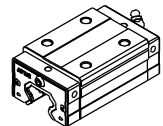

N: Standard

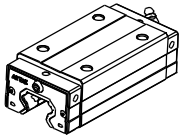

L: Long

① Model Code	LSH: Standard Type Linear Guide				
② Coating on block	Blank: Block without additional coating. (natural color) ★ B: Block coated with black chrome				
③ Rail Width	15: 15mm 20: 20mm 25: 23mm 30: 28mm 35: 34mm 45: 45mm				
④ Block Code	BK: Block				
⑤ Block Style	H: Square type F1: Flange type, Mounting from top F2: Flange type, Mounting from bottom F3: Flange type, Mounting from top or bottom				
⑥ Block type	N: Standard L: Long [w/o 15 series]				
⑦ Accuracy	N: Normal H: High				
⑧ Group code	SA SB SC SE SF B C E [Note1]				
⑨ Nipple / adapter type	15 M4: M4 Nipple AM6: M4 to M6 LM6: M4 to M6	I type L type	20 25 30 35 M6: M6 Nipple A01: M6 to PT1/8 AM8: M6 to M8 L01: M6 to PT1/8 LM8: M6 to M8 SM6: M6 Nipple	I type L type	45 P01: PT1/8 Nipple A01: PT1/8 to PT1/8 AM8: PT1/8 to M8 L01: PT1/8 to PT1/8 LM8: PT1/8 to M8 SP01: PT1/8 Nipple

★ [Note 1] Dustproof standard type please refer to Pg. 26. for more detail.

★ [Note 2] Self-lubricator standard type please refer to Pg. 30. for more detail.

Add: When selecting rails and bearings, the different pairing codes can change the units preload. details see "preload pairing chart".

### 2. Rail Order Information

LSH 15 RL X 4000-H-E-T

① ② ③ ④ ⑤ ⑥ ⑦

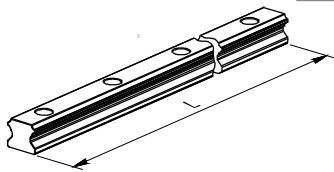

① Model Code	LSH: Standard Type Linear Guide			
② Rail Width	15: 15mm 20: 20mm 25: 23mm 30: 28mm 35: 34mm 45: 45mm			
③ Rail Code	RL: Rail			
④ Rail Length	15: 4040mm 20: 4040mm 25: 4040mm 30: 4030mm 35: 4030mm 45: 4020mm			
⑤ Accuracy	N: Normal H: High			
⑥ Group code	E [Note]			
⑦ Rail type	Blank: Top-mount T: Bottom-mount			

Note: ● For LSH15/20/25, both margin pitch of rail are 40mm.

● For LSH30/35, both margin pitch of rail are 55mm.

● For LSH45, both margin pitch of rail are 67.5mm.

● When selecting rails and bearings, the different pairing codes can change the units preload. details see "preload pairing chart".

### 3. Rail Order Information

LSH □ 15 RL X 220 - S20 - H - E - T

① ② ③ ④ ⑤ ⑥ ⑦ ⑧ ⑨

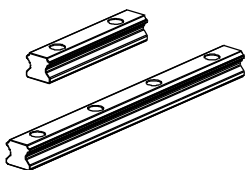

① Model Code	LSH: Standard Type Linear Guide			
② Coating on rail	Blank: Rail without additional coating. (natural color) ★ B: Rail coated with black chrome			
③ Rail Width	15: 15mm 20: 20mm 25: 23mm 30: 28mm 35: 34mm 45: 45mm			
④ Rail Code	RL: Rail			
⑤ Rail Length	220: 220mm ..... [Defined by the customer]			
⑥ Position of first mounting hole	S□ : Distance from end of rail to the center of first mounting hole (It is recommended to be greater than minimum margin)			
⑦ Accuracy	N: Normal H: High			
⑧ Group code	E [Note]			
⑨ Rail type	Blank: Top-mount T: Bottom-mount			

Note: 1. When selecting rails and bearings, the different pairing codes can change the units preload. details see "preload pairing chart".

2. For LSH-B series, standard length of a rail is 3 m.

## LSH Series

### 4. Rail/Block preload pairing chart

When customer orders rail/block, please choose the pairing code of rail/block in accordance with the needed preload of linear guide(combined). Details please refer to the "preload pairing chart".

Model	Rail pairing code	Block pairing code	Preload grade	Model	Rail pairing code	Block pairing code	Preload grade
LSH15 LSH20	E	E	Standard clearance	LSH25	E	E	Standard clearance
		C	Light preload			C	Light preload
		SA	Medium preload			SB	Medium preload
		SE	Heavy Preload				
LSH30	E	E	Standard clearance	LSH35 LSH45	E	E	Standard clearance
		C	Light preload			B	Light preload
		SC	Medium preload			SC	Medium preload
		SF	Heavy Preload			SF	Heavy Preload

### Accessory Order Code

**L - P - AM6 - □**

① ② ③ ④

① Accessory Code	L: Linear Guide Accessory			
② Nipple/adaptor Code	P: Nipple/adaptor			
③ Nipple/adaptor type	M4: M4 Nipple	Nipple	M6: M6 Nipple	Nipple
	AM6: M4 to M6	I type	SM6: M6 Nipple	I type
	LM6: M4 to M6	L type	A01: M6 to PT1/8	I type
			AM8: M6 to M8	
④ Block type			L01: M6 to PT1/8	L type
			LM8: M6 to M8	
			P01: PT1/8 Nipple	Nipple
			SP01: PT1/8 Nipple	I type
		P01A01: PT1/8 to PT1/8	I type	
		P01AM8: PT1/8 to M8		
		P01L01: PT1/8 to PT1/8	L type	
		P01LM8: PT1/8 to M8		

Blank: Standard      ZZ: High dustproof block(both DD and ZZ type)

### Rail Specification

1. The maximum length of a single rail, please refer to the table for more detail about edge pitch of first mounting hole (S) and last mounting hole (E).

2. The edge pitch of first mounting hole (S) and last mounting hole (E) should not be greater than 1/2P. Overlong edge may induce unstable installation and affect the accuracy.

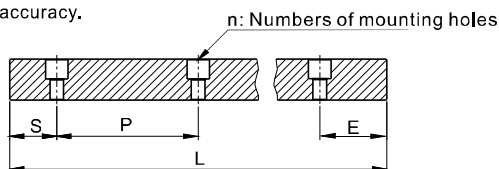

$$L = (n-1) \times P + S + E$$

L: Total length of rail(mm)

n: Numbers of mounting holes on rail

P: Distance between bolt holes(mm)

S: Edge of first mounting hole(mm)

E: Edge of last mounting hole(mm)

Model	LSH15	LSH20	LSH25	LSH30	LSH35	LSH45
Pitch(P)	60	60	60	80	80	105
Standard Edge Pitch(S/E)	40	40	40	55	55	67.5
Min. Edge Pitch(S/E min)	5	6	7	8	8	11
Max. Edge Pitch(S/E max)	55	54	53	72	72	94
Maximum length(Lmax)	4040	4040	4040	4030	4030	4020

Note:

- Joint rail must be chosen if length of rail exceeds the maximum.
- When deciding edge pitch, it should be within the range of above table. There would be risk of broken hole if pitch is out of range.
- Maximum length of rail for standard' means the maximum length of rail can be chosen when both sides of edge pitches are standard.

## LSH Series

### Specifications and Dimensions

#### Square type

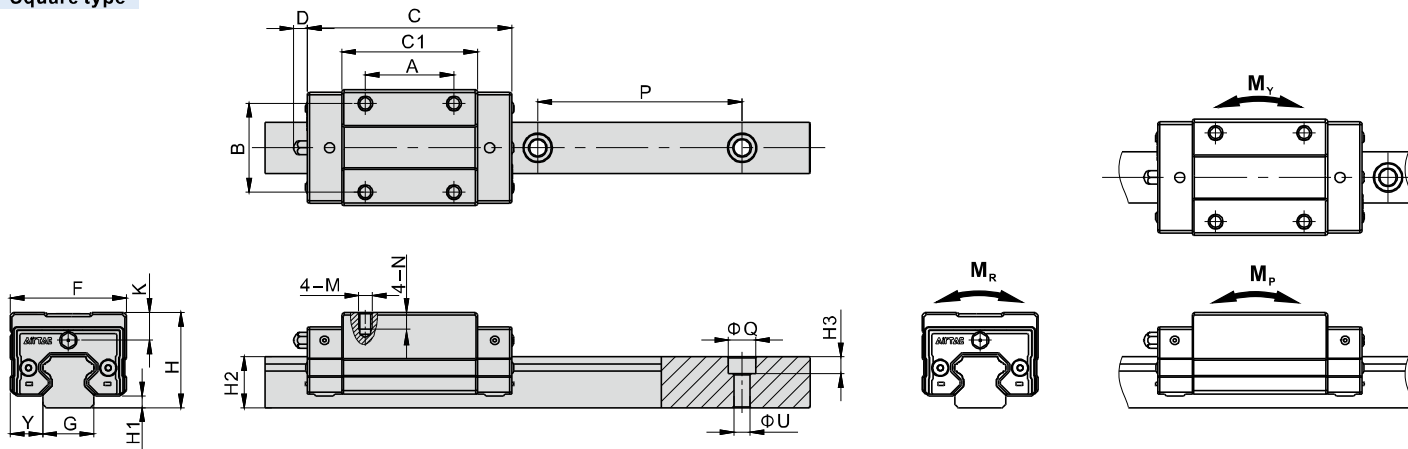

Model\Item	External Dimension ( mm )							Block Dimension ( mm )							Rail Dimension ( mm )					
	H	H1	F	Y	C			C1	A	B	K	D	M	N	G	H2	P	ΦQ	ΦU	H3
					Standard (Blank)	Double oil scrapers(DD)	Oil scraper+Metal scraper(ZZ)													
LSH15HN	28	3.5	34	9.5	60	67	64.5	40	26	26	8.3	6	M4X0.7	5	15	15	60	8	4.8	5.3
LSH20HN	30	4.3	44	12	76.5	84.5	81	52	36	32	6.5	12.5	M5X0.8	6	20	17.5	60	9.5	5.8	8.5
LSH20HL	30	4.3	44	12	90.5	98.5	95	66	50	32	6.5	12.5	M5X0.8	6	20	17.5	60	9.5	5.8	8.5
LSH25HN	40	6.5	48	12.5	83.5	91.5	88	58.5	35	35	10.9	12.5	M6X1.0	8	23	22	60	11.2	7	9
LSH25HL	40	6.5	48	12.5	105	113	109.5	80	50	35	10.9	12.5	M6X1.0	8	23	22	60	11.2	7	9
LSH30HN	45	6.5	60	16	95.5	103.5	100.5	70.5	40	40	11	13	M8X1.25	10	28	26	80	14.2	9	12
LSH30HL	45	6.5	60	16	118	126	123	93	60	40	11	13	M8X1.25	10	28	26	80	14.2	9	12
LSH35HN	55	7	70	18	109	118	114	80	50	50	16.2	12.5	M8X1.25	12	34	29	80	14.2	9	12
LSH35HL	55	7	70	18	134.5	143.5	139.5	105.5	72	50	16.2	12.5	M8X1.25	12	34	29	80	14.2	9	12
LSH45HN	70	10	86	20.5	132	141	137	98	60	60	20	16	M10X1.5	17	45	38	105	20	14	17
LSH45HL	70	10	86	20.5	164	173	169	130	80	60	20	16	M10X1.5	17	45	38	105	20	14	17

Model\Item	Mounting Screw	Dynamic Load Rating(kN)	Static Load Rating(kN)	Static Rated Moment (kN.m)			Weight	
		C	C <sub>0</sub>	M <sub>R</sub>	M <sub>P</sub>	M <sub>V</sub>	Block(kg)	Rail(kg/m)
LSH15HN	M4	11.3	17.9	0.12	0.12	0.12	0.2	1.43
LSH20HN	M5	18.6	28.6	0.27	0.25	0.25	0.33	2.23
LSH20HL	M5	22.2	37.6	0.35	0.34	0.34	0.41	2.23
LSH25HN	M6	26.9	39.4	0.44	0.38	0.38	0.53	3.32
LSH25HL	M6	32.9	53.0	0.58	0.57	0.57	0.7	3.32
LSH30HN	M8	37.4	55.0	0.66	0.67	0.67	0.91	4.5
LSH30HL	M8	45.7	73.1	0.88	0.91	0.91	1.17	4.5
LSH35HN	M8	50.8	72.3	1.05	0.92	0.92	1.26	6.37
LSH35HL	M8	61.9	96.1	1.52	1.45	1.45	1.68	6.37
LSH45HN	M12	80.7	110.3	1.95	1.62	1.62	2.72	10.7
LSH45HL	M12	98.5	146.9	2.59	2.92	2.92	3.60	10.7

# Standard Type Linear Guide

## LSH Series

Flange type, Top-Mount

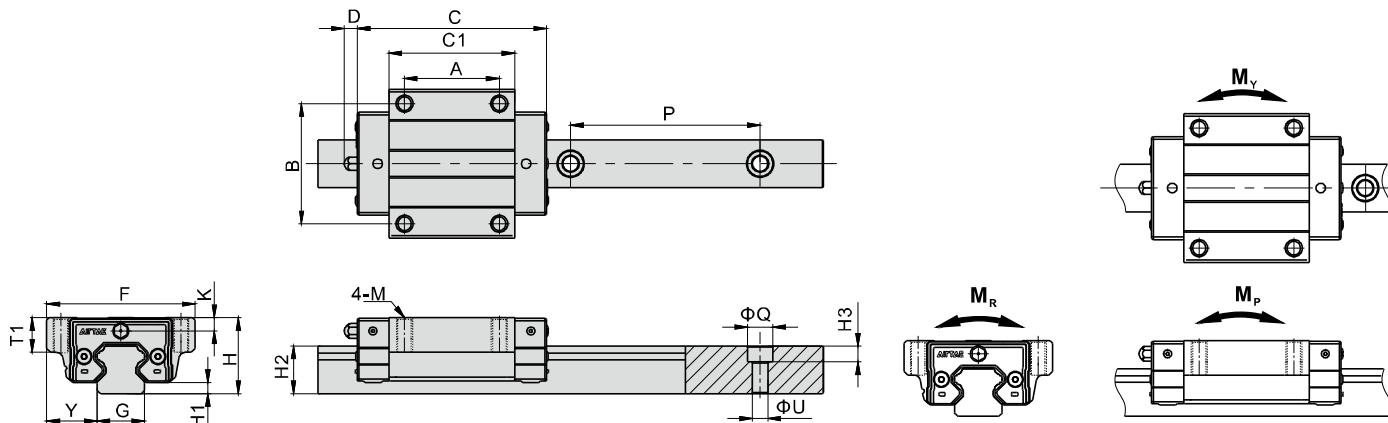

Model/Item	External Dimension ( mm )							Block Dimension ( mm )							Rail Dimension ( mm )					
	H	H1	F	Y	C			C1	A	B	K	D	M	T1	G	H2	P	ΦQ	ΦU	H3
					Standard (Blank)	Double oil scrapers(DD)	Oil scraper+Metal scraper(ZZ)													
LSH15F1N	24	3.5	47	16	60	67	64.5	40	30	38	4.3	6	M5X0.8	11	15	15	60	8	4.8	5.3
LSH20F1N	30	4.3	63	21.5	76.5	84.5	81	52	40	53	6.5	12.5	M6X1.0	10	20	17.5	60	9.5	5.8	8.5
LSH20F1L	30	4.3	63	21.5	90.5	98.5	95	66	40	53	6.5	12.5	M6X1.0	10	20	17.5	60	9.5	5.8	8.5
LSH25F1N	36	6.5	70	23.5	83.5	91.5	88	58.5	45	57	6.9	12.5	M8X1.25	16	23	22	60	11.2	7	9
LSH25F1L	36	6.5	70	23.5	105	113	109.5	80	45	57	6.9	12.5	M8X1.25	16	23	22	60	11.2	7	9
LSH30F1N	42	6.5	90	31	95.5	103.5	100.5	70.5	52	72	8	13	M10X1.5	18	28	26	80	14.2	9	12
LSH30F1L	42	6.5	90	31	118	126	123	93	52	72	8	13	M10X1.5	18	28	26	80	14.2	9	12
LSH35F1N	48	7	100	33	109	118	114	80	62	82	9.2	12.5	M10X1.5	21	34	29	80	14.2	9	12
LSH35F1L	48	7	100	33	134.5	143.5	139.5	105.5	62	82	9.2	12.5	M10X1.5	21	34	29	80	14.2	9	12
LSH45F1N	60	10	120	37.5	132	141	137	98	80	100	10	16	M12X1.75	22	45	38	105	20	14	17
LSH45F1L	60	10	120	37.5	164	173	169	130	80	100	10	16	M12X1.75	22	45	38	105	20	14	17

Model/Item	Mounting Screw	Dynamic Load Rating(kN)	Static Load Rating(kN)	Static Rated Moment (kN.m)			Weight	
		C	C <sub>0</sub>	M <sub>R</sub>	M <sub>P</sub>	M <sub>Y</sub>	Block(kg)	Rail(kg/m)
LSH15F1N	M4	11.3	17.9	0.12	0.12	0.12	0.2	1.43
LSH20F1N	M5	18.6	28.6	0.27	0.25	0.25	0.40	2.23
LSH20F1L	M5	22.2	37.6	0.35	0.34	0.34	0.8	2.23
LSH25F1N	M6	26.9	39.4	0.44	0.38	0.38	0.59	3.32
LSH25F1L	M6	32.9	53.0	0.58	0.57	0.57	0.85	3.32
LSH30F1N	M8	37.4	55.0	0.66	0.67	0.67	1.09	4.5
LSH30F1L	M8	45.7	73.1	0.88	0.91	0.91	1.38	4.5
LSH35F1N	M8	50.8	72.3	1.05	0.92	0.92	1.32	6.37
LSH35F1L	M8	61.9	96.1	1.52	1.45	1.45	1.8	6.37
LSH45F1N	M12	80.7	110.3	1.95	1.62	1.62	2.77	10.7
LSH45F1L	M12	98.5	146.9	2.59	2.92	2.92	3.67	10.7

# Standard Type Linear Guide

## LSH Series

Flange type, Bottom-Mount

Flange type, Top or Bottom-Mount

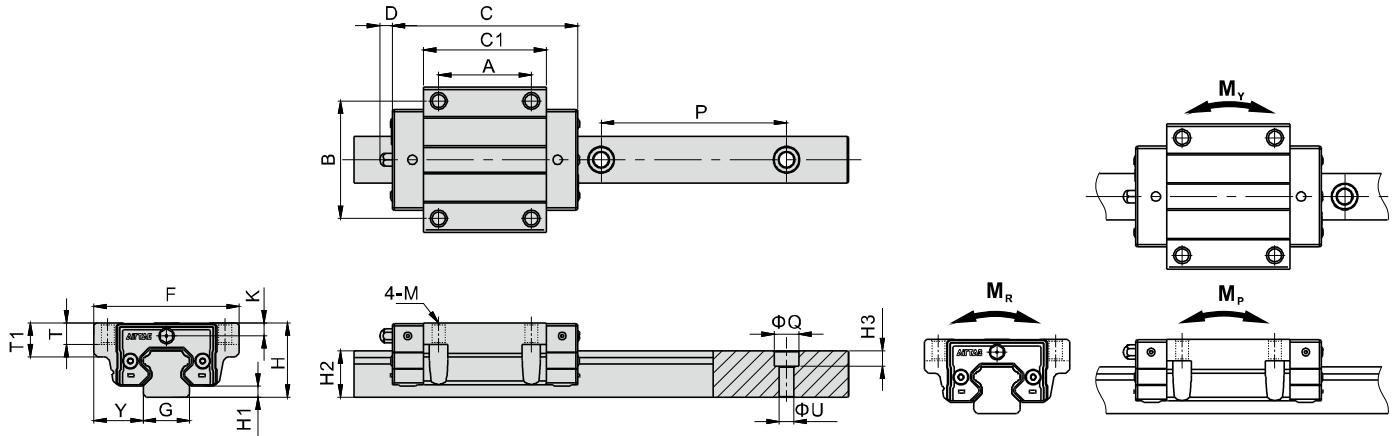

Model/Item	External Dimension(mm)							Block Dimension(mm)							Rail Dimension(mm)							
	H	H1	F	Y	C			C1	A	B	K	D	M		T	T1	G	H2	P	ΦQ	ΦU	H3
					Standard (Blank)	Double oil scrapers(DD)	Oil scraper+Metal scraper(ZZ)						Bottom-Mount	Top or Bottom-Mount								
LSH15F2(F3)N	24	3.5	47	16	60	67	64.5	40	30	38	4.3	6	Φ4.5	M5X0.8	7	11	15	15	60	8	4.8	5.3
LSH20F2(F3)N	30	4.3	63	21.5	76.5	84.5	81	52	40	53	6.5	12.5	Φ5.7	M6X1.0	9.5	10	20	17.5	60	9.5	5.8	8.5
LSH20F2(F3)L	30	4.3	63	21.5	90.5	98.5	95	66	40	53	6.5	12.5	Φ5.7	M6X1.0	9.5	10	20	17.5	60	9.5	5.8	8.5
LSH25F2(F3)N	36	6.5	70	23.5	83.5	91.5	88	58.5	45	57	6.9	12.5	Φ6.8	M8X1.25	10	16	23	22	60	11.2	7	9
LSH25F2(F3)L	36	6.5	70	23.5	105	113	109.5	80	45	57	6.9	12.5	Φ6.8	M8X1.25	10	16	23	22	60	11.2	7	9
LSH30F2(F3)N	42	6.5	90	31	95.5	103.5	100.5	70.5	52	72	8	13	Φ9	M10X1.5	10	18	28	26	80	14.2	9	12
LSH30F2(F3)L	42	6.5	90	31	118	126	123	93	52	72	8	13	Φ9	M10X1.5	10	18	28	26	80	14.2	9	12
LSH35F2(F3)N	48	7	100	33	109	118	114	80	62	82	9.2	12.5	Φ9	M10X1.5	13	21	34	29	80	14.2	9	12
LSH35F2(F3)L	48	7	100	33	134.5	143.5	139.5	105.5	62	82	9.2	12.5	Φ9	M10X1.5	13	21	34	29	80	14.2	9	12
LSH45F2(F3)N	60	10	120	37.5	132	141	137	98	80	100	10	16	Φ11	M12X1.75	15	22	45	38	105	20	14	17
LSH45F2(F3)L	60	10	120	37.5	164	173	169	130	80	100	10	16	Φ11	M12X1.75	15	22	45	38	105	20	14	17

Model/Item	Mounting Screw	Dynamic Load Rating(kN)	Static Load Rating(kN)	Static Rated Moment (kN.m)			Weight	
		C	C <sub>s</sub>	M <sub>e</sub>	M <sub>p</sub>	M <sub>v</sub>	Block(kg)	Rail(kg/m)
LSH15F2(F3)N	M4	11.3	17.9	0.12	0.12	0.12	0.2	1.43
LSH20F2(F3)N	M5	18.6	28.6	0.27	0.25	0.25	0.40	2.23
LSH20F2(F3)L	M5	22.2	37.6	0.35	0.34	0.34	0.8	2.23
LSH25F2(F3)N	M6	26.9	39.4	0.44	0.38	0.38	0.59	3.32
LSH25F2(F3)L	M6	32.9	53.0	0.58	0.57	0.57	0.85	3.32
LSH30F2(F3)N	M8	37.4	55.0	0.66	0.67	0.67	1.09	4.5
LSH30F2(F3)L	M8	45.7	73.1	0.88	0.91	0.91	1.38	4.5
LSH35F2(F3)N	M8	50.8	72.3	1.05	0.92	0.92	1.32	6.37
LSH35F2(F3)L	M8	61.9	96.1	1.52	1.45	1.45	1.8	6.37
LSH45F2(F3)N	M12	80.7	110.3	1.95	1.62	1.62	2.77	10.7
LSH45F2(F3)L	M12	98.5	146.9	2.59	2.92	2.92	3.67	10.7

### Dimension of bottom-mount type rail

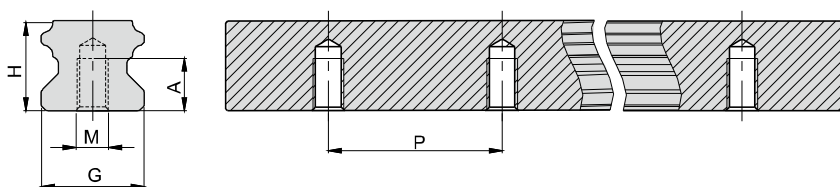

Model/Item	G	H	M	A	P
LSH15T	15	15	M5X0.8	8	60
LSH20T	20	17.5	M6X1.0	10	60
LSH25T	23	22	M6X1.0	12	60
LSH30T	28	26	M8X1.25	15	80
LSH35T	34	29	M8X1.25	17	80
LSH45T	45	38	M12X1.75	24	105

## LSH Series

### Accuracy

LSH standard type linear guide comes with 3 accuracy levels.

	Accuracy Standards (mm)									
	Accuracy	N: Normal			H: High			P: Precision		
	Model	15/20	25/30/35	45	15/20	25/30/35	45	15/20	25/30/35	45
Tolerance of height H	±0.1			±0.03	±0.04	±0.05	±0.015	±0.02	±0.025	
Variation of height ΔH	0.02	0.025	0.03	0.01	0.015		0.006	0.007		
Tolerance of width Y	±0.1			±0.03	±0.04	±0.05	±0.015	±0.02	±0.025	
Variation of width ΔY	0.02	0.03		0.01	0.015	0.02	0.006	0.007	0.01	
Parallelism of C-surface relative to A-surface	Parallelism of raceway (Refer to Table 1)									
Parallelism of D-surface relative to B-surface	Parallelism of raceway (Refer to Table 1)									

Table 1 : Parallelism of the raceway

Rail Length(mm) Accuracy	Accuracy													
	100 under	100~200	200~300	300~500	500~700	700~900	900~1100	1100~1500	1500~1900	1900~2500	2500~3100	3100~3600	3600~4000	
Parallelism of the raceway(μm)	N	12	14	15	17	20	22	24	26	28	31	33	36	37
	H	7	9	10	12	13	15	16	18	20	22	25	27	28
	P	3	4	5	6	7	8	9	11	13	15	18	20	21

### Preload Level

#### 1. Preload interference

The LSH standard type Linear Guide has four preload categories: A, B, C and D.

Choosing suitable preload level will enhance rigidity, precision and torsion resistant performance of the linear guide.

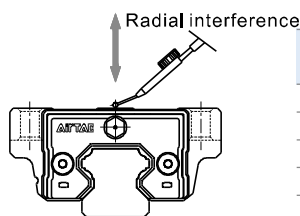

Model	Radial interference(μm)			
	Standard clearance(A)	Light Preload(B)	Medium Preload(C)	Heavy Preload(D)
LSH15	-4~+2	-12~-4	-22~-14	-
LSH20	-5~+2	-13~-5	-23~-15	-
LSH25	-6~+2	-14~-6	-24~-16	-33~-25
LSH30	-7~+2	-16~-7	-29~-20	-38~-29
LSH35	-8~+2	-21~-11	-34~-24	-43~-33
LSH45	-9~+2	-25~-16	-38~-27	-47~-36

#### 2. Common Application

Refer to following table for suitable application of different preload grade:

Preload grade	Requirement	Common Application
Standard clearance(A)	One axial movement, small vibration and impact, accuracy requirement is low	Conveyor Machine, Semiconductor Equipment, Stage Equipment, Press Machine, Welding Machine and other light movement equipments
Light Preload(B)	Equipment that requires light-load and high-precision.	Z-axis movement for industrial use, NC lathe, EDM, Precision XY platform, Vertical machine center, measurement instrument, material feeder or industrial robot
Medium Preload(C)	Equipment that requires high rigidity, large vibration and shock.	Machining centers, NC lathes, grinders, vertical or horizontal milling machines, boring machines, tool guides, heavy cutting machines.
Heavy Preload(D)	Equipment that requires higher rigidity, larger vibration and shock.	Machining centers, NC lathes, grinders, vertical or horizontal milling machines, boring machines, tool guides, heavy cutting machines.

## LSH Series

### Installation Illustration

#### 1. Allowable tolerance of mounting surface

LSH series is an arc-shape, two-point contact design of linear guide. Its self-centering feature allows some tolerance on mounting surface without affecting the smoothness of linear motion. The allowable tolerance is indicated in following table:

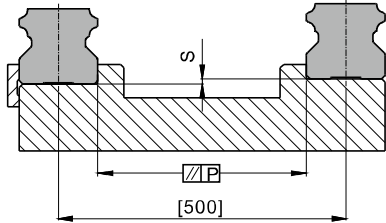

Model	Allowable tolerance of parallelism P(μm)			Allowable tolerance of top and bottom S (μm)		
	Standard clearance(A)	Light Preload(B)	Medium Preload(C)	Standard clearance(A)	Light Preload(B)	Medium Preload(C)
LSH15	25	18	13	130	85	35
LSH20	25	20	18	130	85	50
LSH25	30	22	20	130	85	70
LSH30	40	30	27	170	110	90
LSH35	50	35	30	210	150	120
LSH45	60	40	35	250	170	140

Note: The value in the table is the allowable value when the distance between the two linear guides is 500mm, and the allowable value is proportional to the distance between the two linear guides.

#### 2. Height and Chamfer of Reference Edge

In order to ensure accurate installation of LSH Linear Guide, the contact space should not exceed the given figures in following table.

Unit : mm

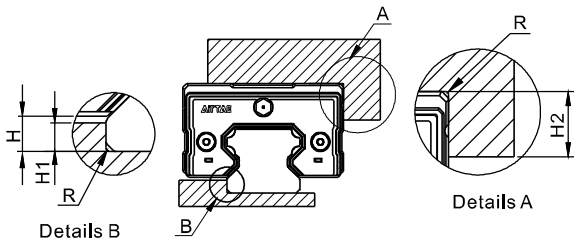

Model	H	H1	H2	R(Max)
LSH15	3.5	3	4	0.5
LSH20	4.3	3.5	5	0.5
LSH25	6.5	5	5	1
LSH30	6.5	5	5	1
LSH35	7	6	6	1
LSH45	10	8	8	1

#### 3. Screw Tighten Torque

When installing linear guide, whether the screws are well tighten and surface is well contacted will affect accuracy significantly. Please refer to following table for tightening force to ensure a perfect installation.

Model	Screw size	Tighten Torque(N.cm)		
		Iron	Casting	Aluminum alloy
LSH15	M4	412	274	206
LSH20	M5	882	588	441
LSH25	M6	1370	921	686
LSH30	M8	3040	2010	1470
LSH35	M8	3040	2010	1470
LSH45	M12	11800	7840	5880

#### 4. Installation and Application

Linear guide installation methods can be divided into the followings. For installations other than forward installation, the lubricant may fail.

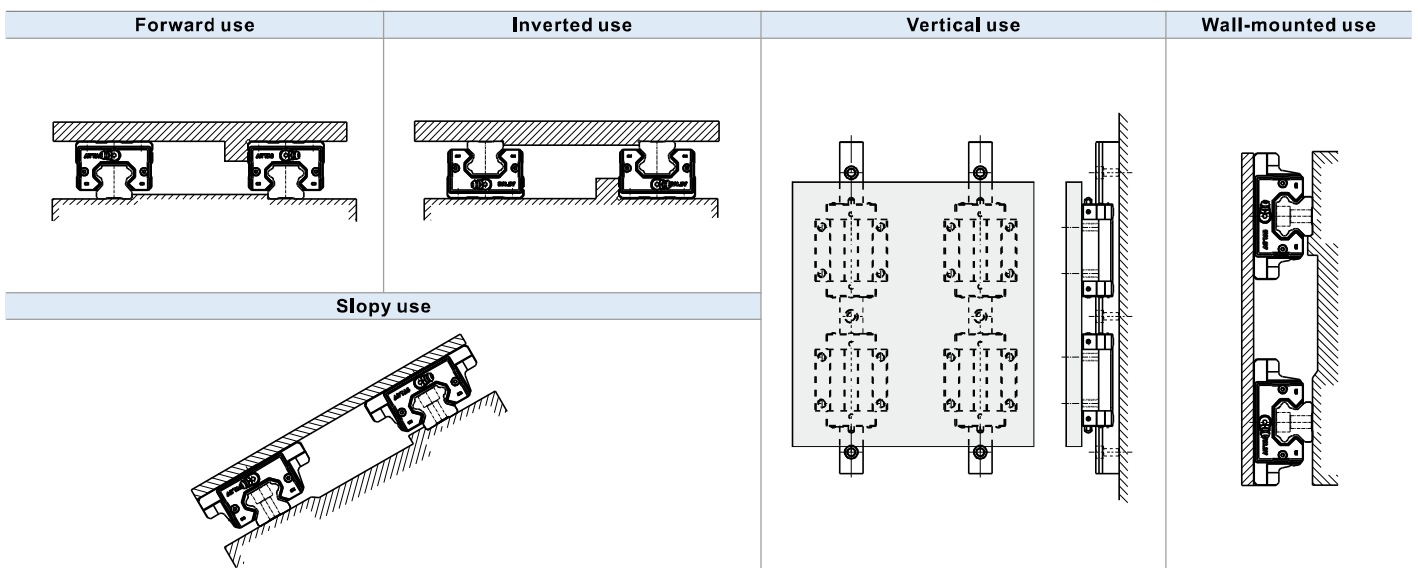

## LSH Series

### 5. Datum plane

- Datum plane for installation must be ground or finely milled to ensure accuracy.
- Both sides of Rail can be used as the datum plane.
- For multi-blocks on a rail, identification line on blocks should be put on the same side to ensure moving accuracy.

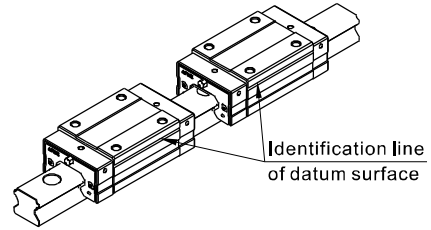

### 6. Fixation Method

Rails and blocks are possible to be displaced while the machine is subjected to vibrations and impacts thus to affect the accuracy. In order to avoid those difficulties and achieve high running accuracy, the following four methods are recommended for fixing.

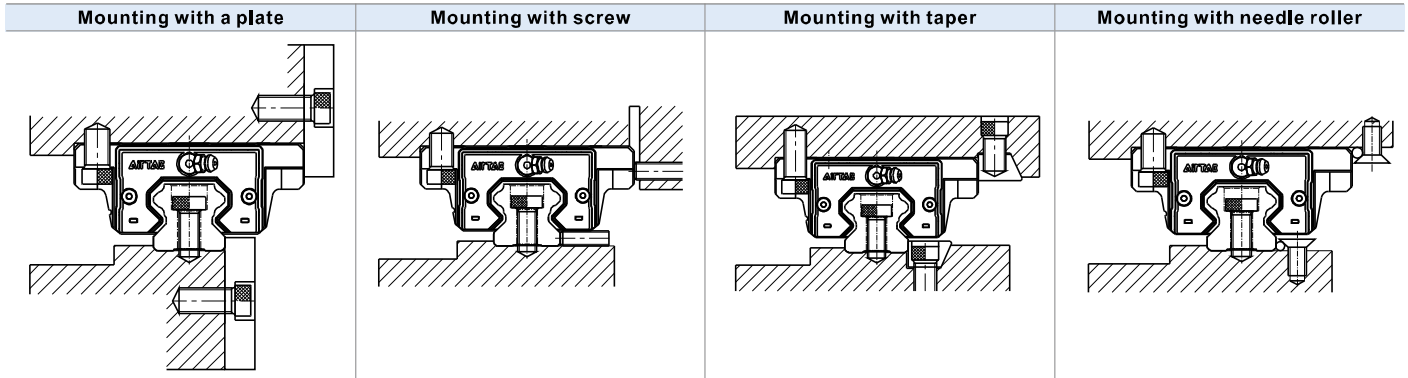

### 7. Rail Installation

A. Before installing the rail, remove all dirt from the mounting surface with oil stone, and then wipe with a clean cloth.

Remove all dirt from the mounting surface with oil stone, and then wipe with a clean cloth

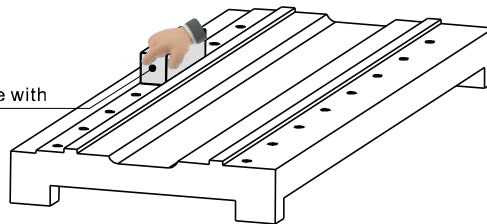

B. Place the rail gently on the bed firstly, then put the bolts into the mounting holes and pre-tighten them, place the rail ① into close contact with the datum plane of the bed by using the baffle, tighten the bolts with appropriate torque to fix the rail. Refer to "3. Screw tighten torque" for recommended torque value.

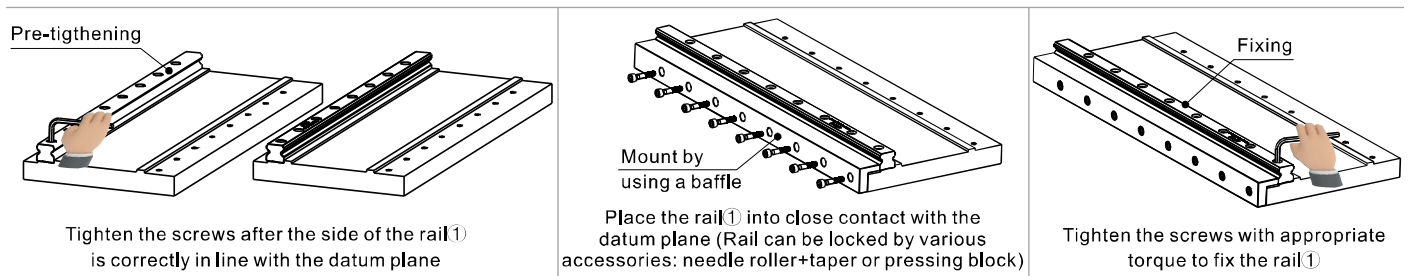

### 8. Block Installation

- Temporarily fix the table on the block by using the mounting bolts.
- Push the block datum plane against the side datum plane of the table and position the block by tightening the set screws.
- Tighten the mounting bolts in 1 to 4 sequences to fix the table on the block.

### 9. Subsidiary Rail Installation

Under the condition that the subsidiary rail has a reference datum plane, remove all dirt from the mounting surface with oil stone, and then wipe with a clean cloth, mount the subsidiary rail ② with the same method of the master rail ①.

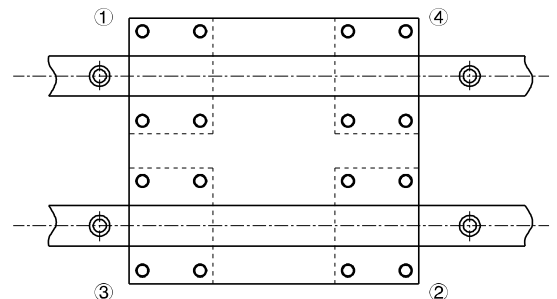
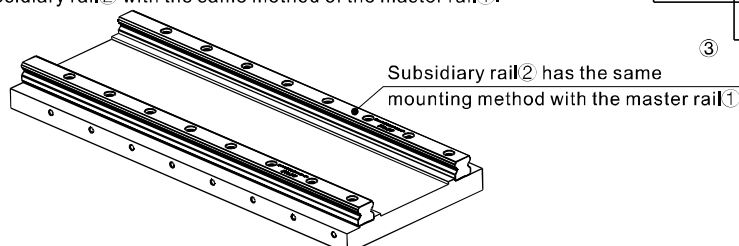

Under the condition that the subsidiary rail ② has a reference datum plane, remove all dirt from the mounting surface with oil stone, and then wipe with a clean cloth.

## LSH Series

### 10. Rail Installation without Side Datum Surface

#### Using a provisional datum plane

Use the datum plane provided on the bed for straight alignment of the rail from one end to the other, attention must be paid to fix two blocks in close contact on the measuring plate.

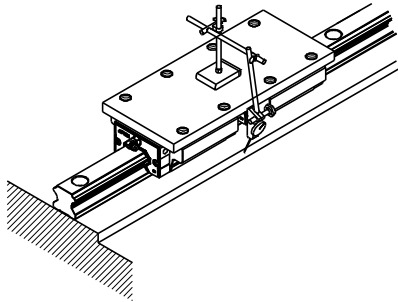

#### Using a straight-edge

Put the straight-edge between the two rails and use a dial gauge to adjust straight-edge in parallel with the side datum plane of the master rail. Use the dial gauge to ensure the straightness of the subsidiary rail by using the straight-edge as reference, then tighten the mounting bolts in proper sequence when the subsidiary rail is parallel to the master rail.

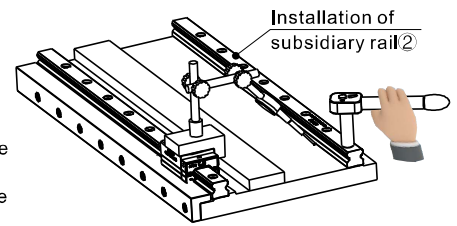

### 11. Rail Installation without Set Screws

To ensure parallelism between the subsidiary rail and the master rail in the condition without set screws, the following installation methods are recommended, and the installation of the block is the same as mentioned previously.

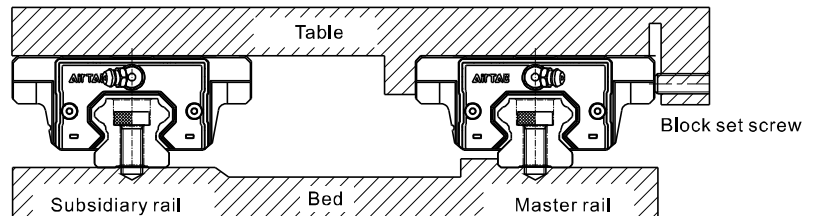

#### Installation of the master rail

##### Using a vice

Put the rail on the bed mounting surface and temporarily fasten the mounting bolts, then push the rail against the side datum plane of the bed by using a vice to ensure the rail position. Tighten the mounting bolts in proper sequence with specific torque.

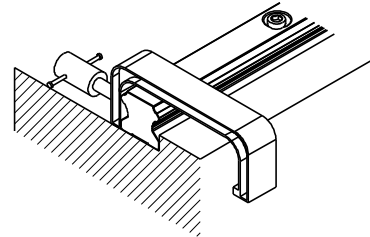

#### Installation of the subsidiary rail

##### Using a straight-edge

Put the straight-edge between the two rails and use a dial gauge to adjust straight-edge in parallel with the side datum plane of the master rail. Use the straight-edge to ensure the straightness of the subsidiary rail, then tighten the mounting bolts in proper sequence with specific torque.

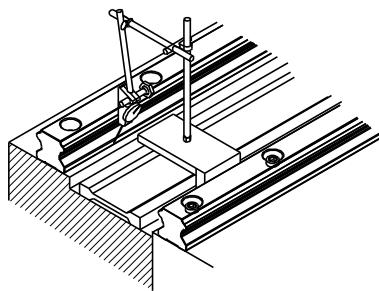

##### Using a table

Fix two blocks on the master rail to the table, and temporarily fix the subsidiary rail to the bed and one block on the subsidiary rail to the table. Place the gauge against the side surface of the block on the subsidiary rail, move the table from one end of the rail to the other end, then tighten the mounting bolts in proper sequence with specific torque while aligning the subsidiary rail parallel to the master rail.

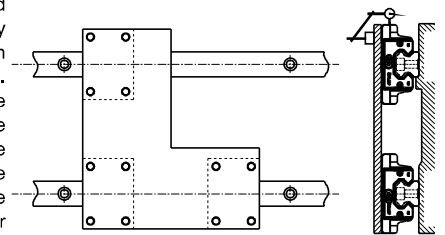

##### Following the master rail

Fix the table to the two blocks on the master rail and one of the two blocks on the subsidiary rail, temporarily fix the other block on the subsidiary rail to the table and subsidiary rail to the bed. Moving the table from one end of the master rail and tighten the mounting bolts on the subsidiary rail in proper sequence with specific torque at the same time.

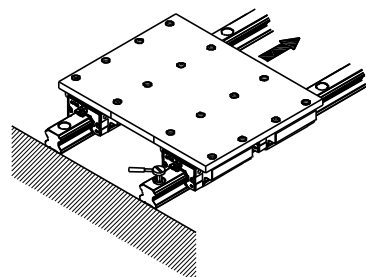

##### Using a jig

Use a special jig to help ensure the position of the subsidiary rail, and tighten the mounting bolts in proper sequence with specific torque.

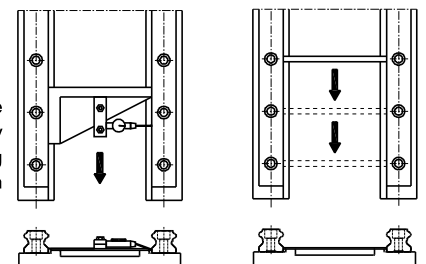

## LSH Series

### 12. Rail Butt-jointed

- When it comes to butt-jointed rail installation, it must follow the butt-jointed marks shown below.
- In order to avoid the accuracy caused by installing the matched jointed rails, it is recommended to stagger the butt-jointed positions, see figure below.

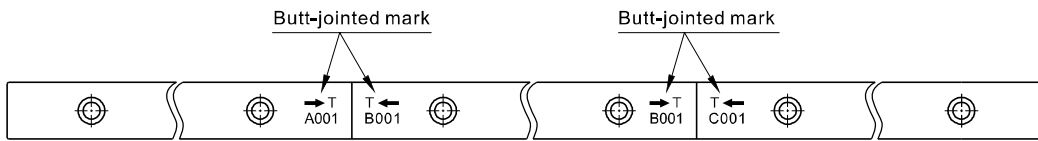

- When jointing rails, it must follow group marks on rail to ensure the accuracy of linear guide. These marks are located on the top surface at joint side. Please put the same group marks together.

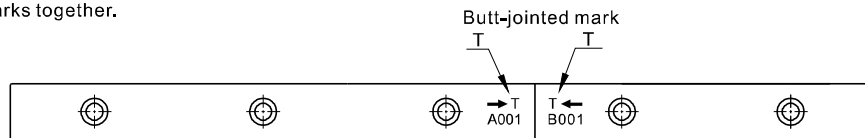

- Be aware serial number of group mark when assemble. A001 and B001 are in a group, so as to A002 and B002 and so on.
- Be aware the installation direction while assembly, the serial numbers are not upside down and arrows point to each other.

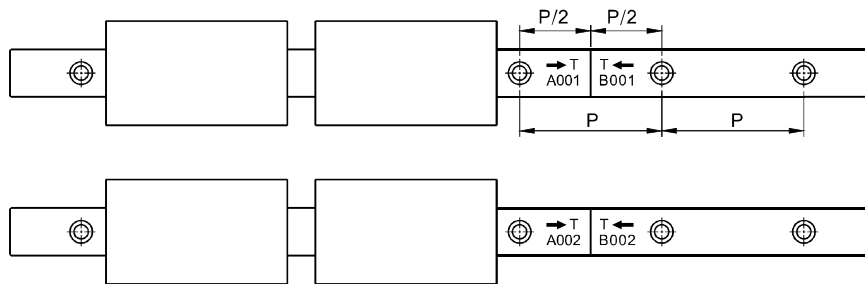

### 13. Measurement Method after Installation

When measuring running accuracy of the block, two blocks should be fixed on an inspection table in close contact to obtain stable accuracy. When using a dial gauge, a provisional benchmark (like a straight-edge) is recommended to put as close as possible to the block for accurate measurement.

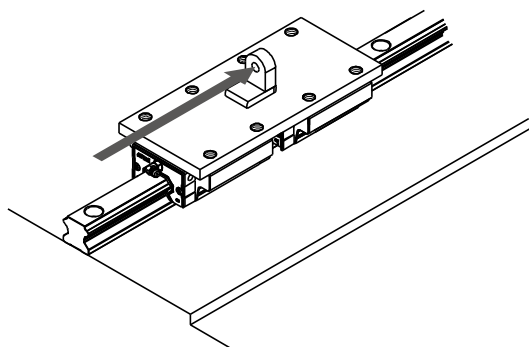

Method using an autocollimator

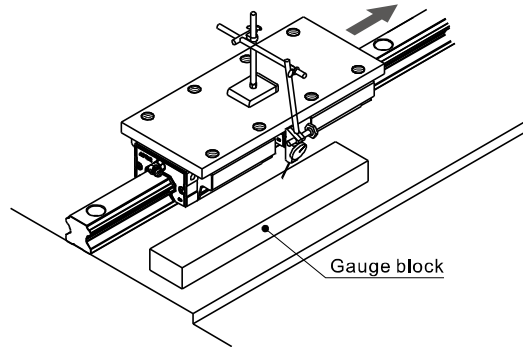

Method using a dial gauge

## LSH Series

### Lubrication method

When a linear guide is well lubricated, it can reduce wear and increase lifespan significantly. Lubrication has the following benefits :

- Reduces friction of the rollers and raceway to minimize wear.
- The grease film between contact surface can prevent roller fatigue.
- Prevent rust.

#### 1. Lubrication Grease

Use the correct grade of lubrication. While lubricating, a grease gun can be used to pump grease into slider through the grease nipple on it. The suitable condition for lube is when working speed is under 60 m/min and not in cooling process.

•Nipple type	L-P-M4	L-P-M6	L-P-SM6	L-P-P01	L-P-SP01
Grease nipple type	<b>LSH15</b>  M4X0.7P Dimensions: 5, 12	<b>LSH20</b> <b>LSH25</b> <b>LSH30</b> <b>LSH35</b>  M6X0.75P Dimensions: 5.8, 20	<b>LSH20</b> <b>LSH25</b> <b>LSH30</b> <b>LSH35</b>  M6X0.75P Dimensions: 5.8, 14.8	<b>LSH45</b>  PT1/8 Dimensions: 7.5, 21.5	<b>LSH45</b>  PT1/8 Dimensions: 7.5, 16.5

#### •Grease amount

LSH series linear guide is well lubricated with 'Mobilith EP2' in factory. Customers are recommended to use identical or the same grade of lubricant. After lubrication, block needs to be moved back and forth at least three times for the length of three blocks and repeat at least twice. Check if the surface of rail is well covered by grease film.

Model	Grease amount for the first lubrication(cm <sup>3</sup> )		Replenishment amount(cm <sup>3</sup> )	
	Standard type	Long type	Standard type	Long type
LSH15	0.9	-	0.3	-
LSH20	1.8	2.7	0.6	0.9
LSH25	3.6	4.5	1.1	1.4
LSH30	5.4	7.2	1.7	2.2
LSH35	8.1	10	2.5	3
LSH45	8.4	10.4	2.8	3.5

#### •Lubrication frequency

Although the linear guides are well lubricated at the factory and retains grease well, frequent lubrication is still necessary to avoid undesirable wear. Recommended lubrication period is every 100km of movement or every 3~6 months. (Refer to table on the top for suggested amount)

#### 2. Lubricating oil

Recommended oil viscosity for lubrication use is about 30 to 150 cst.

Lubrication oil is suitable for all kinds of load and impact application, but not for high temperature use due to its tendency of vaporization.

#### •Adaptor

L-P-AM6	L-P-AM8	L-P-A01
 M6X0.75P M4X0.7P Dimensions: 7.4, 9, 17, 3, 5.5 LSH15	 M8X1P Inner bushing (Use with soft tube, for hard tube is unnecessary) M6X0.75P Dimensions: 10, 8, 10, 19.3, 3.5, 9 LSH35 LSH30 LSH25 LSH20	 PT1/8 M6X0.75P Dimensions: 11, 12, 21.3, 3.5, 9 LSH35 LSH30 LSH25 LSH20
L-P-LM6	L-P-LM8	L-P-L01
 M6X0.75P M4X0.7P Dimensions: 10, 16, 5.5, 8, 3, 7 LSH15	 M8X1P Inner bushing (Use with soft tube, for hard tube is unnecessary) M6X0.75P Dimensions: 10, 19.3, 3.5, 9, 10, 8 LSH35 LSH30 LSH25 LSH20	 PT1/8 M6X0.75P Dimensions: 11, 21.3, 12, 3.5, 9, 11 LSH35 LSH30 LSH25 LSH20

## LSH Series

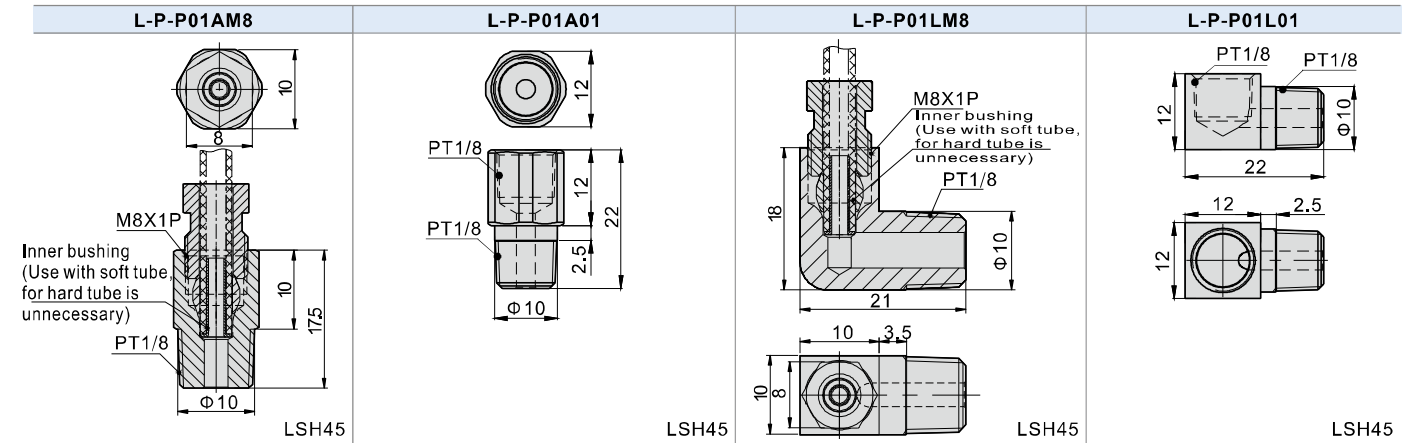

Note: After installation, the top surface of adaptor may be higher than block. Be careful about the interference while moving.

## Lubrication method

### Oil supply rate

Loss of lubrication oil is faster than lubrication grease. Pay attention to sufficiency of oil while using.

Model	Oil amount for the first lubrication(cm <sup>3</sup> )	Feeding Speed(cm <sup>3</sup> /hr)
LSH15	0.6	0.2
LSH20	0.6	0.2
LSH25	0.9	0.3
LSH30	0.9	0.3
LSH35	0.9	0.3
LSH45	0.9	0.3

### 3. Grease nipple/adaptor installation

- Grease nipple or adaptor can be installed in the two sides of block for manual or automatic lubrication based on customer's requirement.
- There are a secondary set of lubricating ports on the side of the block. When using, it is not recommended to use the side with datum line unless necessary.
- Lateral nipple installation is not recommended for flange type blocks. (The grease / oil nipple may interfere with block)
- If lateral lubrication is needed for above spec, please contact us for customization.

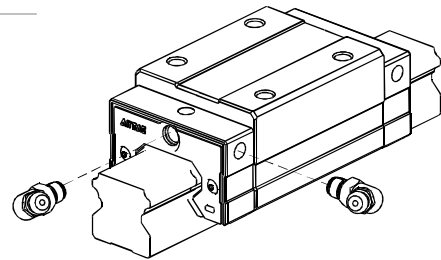

## Bolt hole plug

### 1. Plug type

In order to prevent metal swarf or external objects from entering blocks and affecting precision and lifespan, customers must put plugs into holes during installation. Every rail is equipped with default plugs.

Model	Bolt	Diameter(D)(mm)	Thickness(H)(mm)
LSH15	M4	8.15	1.1
LSH20	M5	9.65	2.5
LSH25	M6	11.4	2.5
LSH30	M8	14.4	3.5
LSH35	M8	14.4	3.5
LSH45	M12	20.2	4.5

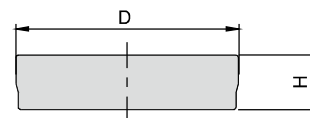

### 2. Plug installation Steps

#### Step one

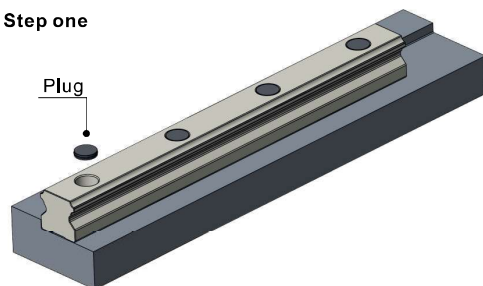

Place the plug in counterbore.

- Note :
- Please make sure the plugs do not protrude the rail surface.
  - After installation, please clean the surface before use.

#### Step two

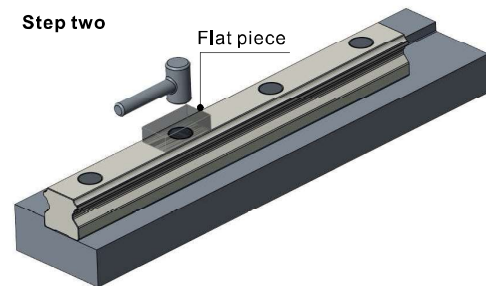

Place the flat piece on mounting hole, hit the piece vertically with a plastic hammer and fix the plug into counterbore.

# Dustproof standard type linear guide

## LSH Series



### Order Information(Combined)

LSH □ 15 H N 1 X220 S20 A H - AM6 - B - T - DD

① ② ③ ④ ⑤ ⑥ ⑦ ⑧ ⑨ ⑩ ⑪ ⑫ ⑬ ⑭

① Model Code	LSH:Dustproof standard type linear guide		
② Rail&Block surface treatment	Blank: without additional coating. (natural color) ★BB : Block and rail coated with black chrome		
③ Rail Width	15: 15mm 20: 20mm 25: 23mm 30: 28mm 35: 34mm 45: 45mm		
④ Block Style	H: Square type F1: Flange type, Mounting from top F2: Flange type, Mounting from bottom F3: Flange type, Mounting from top or bottom		
⑤ Block type	N: Standard L: Long [w/o 15 series]		
⑥ Number of Block	1: One 2: Two [Note: Amount of block on a single set of linear guide]		
⑦ Length of Rail	220:220mm .....[Defined by customer]		
⑧ Position of first mounting hole	S□ : Distance from end of rail to the center of first mounting hole (It is recommended to be greater than minimum margin)		
⑨ Preload	A: Standard clearance B: Light Preload C: Medium Preload D: Heavy Preload		
⑩ Accuracy	N : Normal H : High P : Precision		
⑪ Nipple /adapter type	M4: M4 Nipple	M6: M6 Nipple	P01: PT1/8 Nipple
	AM6: M4 to M6 I type	A01: M6 to PT1/8 I type	A01: PT1/8 to PT1/8 I type
	LM6: M4 to M6 L type	L01: M6 to PT1/8 L type	AM8: PT1/8 to M8 L01: PT1/8 to PT1/8 L type
		SM6: M6 Nipple	LM8: PT1/8 to M8 SP01: PT1/8 Nipple
⑫ Packing type	Blank: the block and rail are assembled B: block and rail are put separately		
⑬ Rail type	Blank: Top-mount T: Bottom-mount		
⑭ Dust proof	DD: Double oil scrapers ZZ: Oil scraper + metal scraper		

[Note 1] For LSH-BB series, standard length of a rail is 3 m.

Please contact with our company if length of rail exceeds the maximum.

Add: Heavy preload is available for LSH25/30/35/45 only.

# Dustproof standard type linear guide

## LSH Series

### Butt-jointed Order Information

LSH □ 15 H N 1X2970 T 2940 T 2970 A H-AM6-B-T-DD



Butt-jointed end margin: 1/2P ,  
Position of the first and last  
hole is defined by customer.

① Model Code	LSH:Dustproof standard type linear guide		
② Rail&Block surface treatment	Blank: without additional coating. (natural color) ★BB : Block and rail coated with black chrome		
③ Rail Width	15: 15mm 20: 20mm 25: 23mm 30: 28mm 35: 34mm 45: 45mm		
④ Block Style	H: Square type F1: Flange type, Mounting from top F2: Flange type, Mounting from bottom F3: Flange type, Mounting from top or bottom		
⑤ Block type	N: Standard L: Long [w/o 15 series]		
⑥ Number of Block	1: One 2: Two [Note: Amount of block on a single set of linear guide]		
⑦ Length of first Rail	2970:2970mm .....[Defined by customer]		
⑧ Butt-jointed mark	T: Rail Butt-jointed mark (Butt-jointed end margin: 1/2P) [P is the standard hole distance]		
⑨ Length of second Rail	2940:2940mm .....[Defined by customer]		
⑩ Butt-jointed mark	Blank: two rails joint T: Rail Butt-jointed mark (Butt-jointed end margin: 1/2P) [P is the standard hole distance]		
⑪ Length of third Rail	Blank: two rails joint 2970:2970mm.....[Defined by customer]		
⑫ Preload	A: Standard clearance B: Light Preload C: Medium Preload D: Heavy Preload		
⑬ Accuracy	N : Normal H : High		
⑭ Nipple /adapter type	M4: M4 Nipple	M6: M6 Nipple	P01: PT1/8 Nipple
	AM6: M4 to M6 I type	A01: M6 to PT1/8 I type	A01: PT1/8 to PT1/8 I type
	20 25 30 35 LM6: M4 to M6 L type	AM8: M6 to M8 L type	AM8: PT1/8 to M8 L type
	LM6: M4 to M6 L type	L01: M6 to PT1/8 L type	L01: PT1/8 to PT1/8 L type
	LM8: M6 to M8	LM8: PT1/8 to M8	
	SM6: M6 Nipple	SP01: PT1/8 Nipple	
⑮ Packing type	Blank: the block and rail are assembled B: block and rail are put separately		
⑯ Rail type	Blank: Top-mount T: Bottom-mount		
⑰ Dust proof	DD: Double oil scrapers ZZ: Oil scraper + metal scraper		

[Note1] For LSH-BB series, standard length of a rail is 3 m.  
Maximum length of two-joint rail is 6 m, Maximum length of three-joint rail is 9 m.  
Please contact with our company if length of rail exceeds the maximum.  
Add1: Number of joints cannot be more than 2 times(three rails at most).  
For LSH15/20/25, maximum length of jointed rail is 12080mm.  
For LSH30/35, it's 12030. For LSH45, it's 12000.  
Customization is needed for joint times more than standard.  
Add2: Heavy preload is available for LSH25/30/35/45 only.

# Dustproof standard type linear guide

## LSH Series

### 1. Block Order Information

LSH □ 15 BK-H N-H-E-AM6-DD

① ② ③ ④ ⑤ ⑥ ⑦ ⑧ ⑨ ⑩

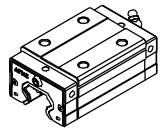

N: Standard

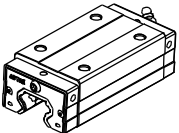

L: Long

① Model Code	LSH:Dustproof standard type linear guide						
② Coating on block	Blank: Block without additional coating. (natural color) ★B: Block coated with black chrome						
③ Rail Width	15: 15mm 20: 20mm 25: 23mm 30: 28mm 35: 34mm 45: 45mm						
④ Block Code	BK: Block						
⑤ Block Style	H: Square type F1: Flange type, Mounting from top F2: Flange type, Mounting from bottom F3: Flange type, Mounting from top or bottom						
⑥ Block type	N: Standard L: Long [w/o 15 series]						
⑦ Accuracy	N: Normal H: High						
⑧ Group code	SA SB SC SE SF B C E[Note1]						
⑨ Nipple /adapter type	15	M4: M4 Nipple		45	P01:PT1/8 Nipple		
		AM6: M4 to M6 I type			A01:PT1/8 to PT1/8 I type		
	20 25 30 35	L type	AM8: M6 to M8		AM8:PT1/8 to M8		
			L01:M6 to PT1/8 L type		L01:PT1/8 to PT1/8 L type		
		SM6:M6 Nipple		LM8:PT1/8 to M8		SP01:PT1/8 Nipple	
⑩ Dust proof	DD: Double oil scrapers ZZ: Oil scraper + metal scraper						

[Note1]: When selecting rails and bearings, the different pairing codes can change the units preload. details see "preload pairing chart".

## LSH Series

### Dust prevention illustration

#### 1. Code and structure

AirTAC provides the following dust prevention accessories for the linear guides working in dusty environment, if the following accessories are demanded, please add the corresponding code when ordering.

Code	Blank: Standard	DD: Double oil scrapers	ZZ: Metal scraper + Oil scraper
Structure	<p>Top seal Side seal Oil scraper</p>	<p>Top seal Side seal (Enhanced) Double oil scrapers (Double lips, enhanced)</p>	<p>Top seal Side seal (Enhanced) oil scrapers (Double lips, enhanced) Metal scraper</p>

#### 2. Test for high dust prevention

##### 2.1. Test item

Test medium	Wood chip	Iron filing	Gravel
Running distance	500km	500km	500km

##### 2.2. Test equipment

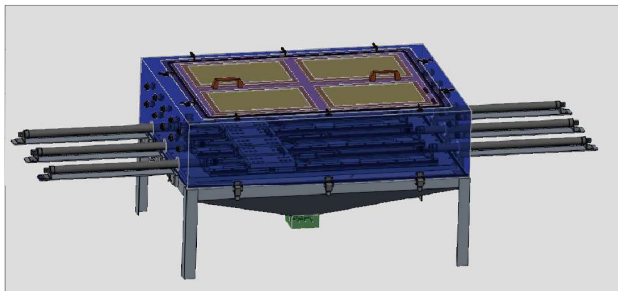

Figure1: Dust tester (Appearance)



Figure2: Dust tester (Inside)

##### 2.3. Test condition

AirTAC adopts the industry's first dust tester (Figure 1) to simulate real working conditions, 360° without dead angles, all-round dust invasion (Figure 2). The dustproof test simulates multiple application scenarios, fully fill the air with wood chips, iron filings and gravels and are strictly tested to ensure the quality and dustproof effect of each block.

##### 2.4. Test result

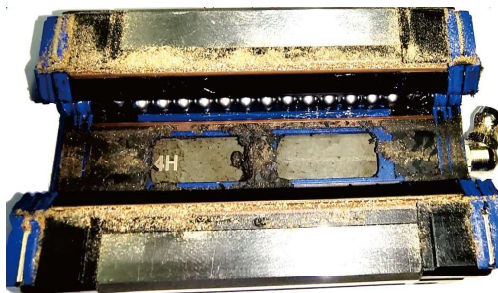

Figure3: Steel balls



Figure4: Steel balls

Result: It can be seen from the Figure 3 and 4 that little amount of dust enters the inside of the block after testing, and the steel ball surface is still smooth, the block still runs smoothly and the performance is not affected.

Note: The above test results are obtained from AirTAC lab.

#### 3. Dimensions

Highly dustproof type blocks have different length compared with the standard blocks (only dimension C is different from the standard, the others keep same), see the table on the right for details.

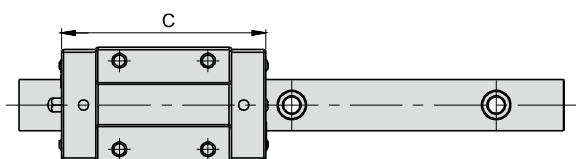

Model	Type	Length C(mm)		
		Standard (Blank)	Double oil scrapers(DD)	Oil scraper+Metal scraper(ZZ)
LSH15□N	Standard	60	67	64.5
LSH20□N	Standard	76.5	84.5	81
LSH20□L	Long	90.5	98.5	95
LSH25□N	Standard	83.5	91.5	88
LSH25□L	Long	105	113	109.5
LSH30□N	Standard	95.5	103.5	100.5
LSH30□L	Long	118	126	123
LSH35□N	Standard	109	118	114
LSH35□L	Long	134.5	143.5	139.5
LSH45□N	Standard	132	140.5	136.5
LSH45□L	Long	163.5	172	168

# Self-lubricator Standard Linear Guide



## LSH Series

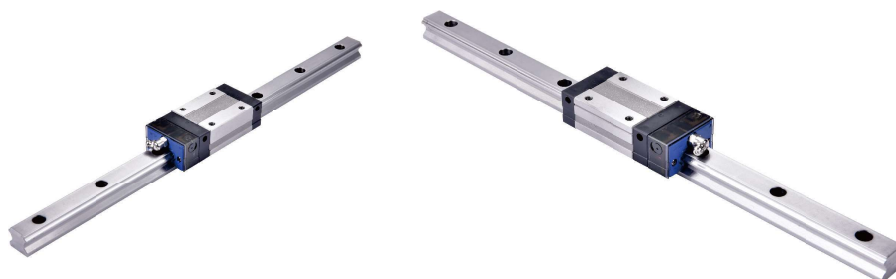

### Order Information(Combined)

LSH □ 15 H N 1 X220 S20 A H - AM6 - B - T - E

① ② ③ ④ ⑤ ⑥ ⑦ ⑧ ⑨ ⑩ ⑪ ⑫ ⑬ ⑭

① Model Code	LSH: Self-lubricator Standard Linear Guide		
② Rail&Block surface treatment	Blank: without additional coating. (natural color) ★BB : Block and rail coated with black chrome		
③ Rail Width	15: 15mm 20: 20mm 25: 23mm 30: 28mm 35: 34mm 45: 45mm		
④ Block Style	H: Square type F1: Flange type, Mounting from top F2: Flange type, Mounting from bottom F3: Flange type, Mounting from top or bottom		
⑤ Block type	N: Standard L: Long [w/o 15 series]		
⑥ Number of Block	1: One 2: Two [Note: Amount of block on a single set of linear guide]		
⑦ Length of Rail	220: 220mm .....[Defined by customer]		
⑧ Position of first mounting hole	S□ : Distance from end of rail to the center of first mounting hole (It is recommended to be greater than minimum margin)		
⑨ Preload	A: Standard clearance B: Light Preload C: Medium Preload D: Heavy Preload		
⑩ Accuracy	N : Normal H : High P : Precision		
⑪ Nipple /adapter type	M4: M4 Nipple	M6: M6 Nipple	P01: PT1/8 Nipple
	AM6: M4 to M6	A01: M6 to PT1/8	A01: PT1/8 to PT1/8
	LM6: M4 to M6	AM8: M6 to M8	AM8: PT1/8 to M8
		L01: M6 to PT1/8	L01: PT1/8 to PT1/8
		LM8: M6 to M8	LM8: PT1/8 to M8
		SM6: M6 Nipple	SP01: PT1/8 Nipple
⑫ Packing type	Blank: the block and rail are assembled B: block and rail are put separately		
⑬ Rail type	Blank: Top-mount T: Bottom-mount		
⑭ Self-lubricator Standard Type	E: Self-lubricator Standard Type		

[Note1] For LSH-BB series, standard length of a rail is 3 m.

Please contact with our company if length of rail exceeds the maximum.

Add: Heavy preload is available for LSH25/30/35/45 only.



# Self-lubricator Standard Linear Guide















## LSH Series

### Butt-jointed Order Information

LSH □ 15 H N 1X2970 T 2940 T 2970 A H-AM6-B - T- E

① ② ③ ④ ⑤ ⑥ ⑦ ⑧ ⑨ ⑩ ⑪ ⑫ ⑬ ⑭ ⑮ ⑯ ⑰

Butt-jointed end margin:1/2P ,  
Position of the first and last  
hole is defined by customer.

① Model Code	LSH:Self-lubricator Standard Linear Guide		
② Rail&Block surface treatment	Blank: without additional coating. (natural color) ★BB : Block and rail coated with black chrome		
③ Rail Width	15: 15mm 20: 20mm 25: 23mm 30: 28mm 35: 34mm 45: 45mm		
④ Block Style	H: Square type F1: Flange type, Mounting from top F2: Flange type, Mounting from bottom F3: Flange type, Mounting from top or bottom		
⑤ Block type	N: Standard L: Long [w/o 15 series]		
⑥ Number of Block	1: One 2: Two [Note: Amount of block on a single set of linear guide]		
⑦ Length of first Rail	2970:2970mm .....[Defined by customer]		
⑧ Butt-jointed mark	T: Rail Butt-jointed mark (Butt-jointed end margin:1/2P) [P is the standard hole distance]		
⑨ Length of second Rail	2940:2940mm .....[Defined by customer]		
⑩ Butt-jointed mark	Blank: two rails joint T: Rail Butt-jointed mark (Butt-jointed end margin:1/2P) [P is the standard hole distance]		
⑪ Length of third Rail	Blank: two rails joint 2970:2970mm.....[Defined by customer]		
⑫ Preload	A: Standard clearance B: Light Preload C: Medium Preload D: Heavy Preload		
⑬ Accuracy	N : Normal H : High		
⑭ Nipple /adapter type	M4: M4 Nipple 	M6: M6 Nipple 	P01: PT1/8 Nipple 
	AM6: M4 to M6 I type 	A01: M6 to PT1/8 I type 	A01: PT1/8 to PT1/8 I type 
	20 25 30 35 L type 	LM8: M6 to M8 L type 	AM8: PT1/8 to M8 L type 
	LM6: M4 to M6 L type 	SM6: M6 Nipple 	L01: PT1/8 to PT1/8 L type 
⑮ Packing type	Blank: the block and rail are assembled B: block and rail are put separately		
⑯ Rail type	Blank: Top-mount T: Bottom-mount		
⑰ Self-lubricator Standard Type	E: Self-lubricator Standard Type		

[Note1] For LSH-BB series, standard length of a rail is 3 m.

Maximum length of two-joint rail is 6 m. Maximum length of three-joint rail is 9 m.  
Please contact with our company if length of rail exceeds the maximum.

Add1: Number of joints cannot be more than 2 times(three rails at most).

For LSH15/20/25, maximum length of jointed rail is 12080mm.

For LSH30/35, it's 12030. For LSH45, it's 12000.

Customization is needed for joint times more than standard.

Add2: Heavy preload is available for LSH25/30/35/45 only.

# Self-lubricator Standard Linear Guide

## LSH Series

### 1. Block Order Information

LSH □ 15 BK-H N-H-E-AM6-E

① ② ③ ④ ⑤ ⑥ ⑦ ⑧ ⑨ ⑩

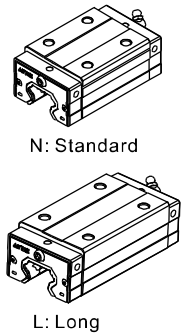

① Model Code	LSH: Self-lubricator Standard Linear Guide																																							
② Coating on block	Blank: Block without additional coating, (natural color) ★ B: Block coated with black chrome																																							
③ Rail Width	15: 15mm 20: 20mm 25: 23mm 30: 28mm 35: 34mm 45: 45mm																																							
④ Block Code	BK: Block																																							
⑤ Block Style	H: Square type F1: Flange type, Mounting from top F2: Flange type, Mounting from bottom F3: Flange type, Mounting from top or bottom																																							
⑥ Block type	N: Standard L: Long [w/o 15 series]																																							
⑦ Accuracy	N: Normal H: High																																							
⑧ Group code	SA SB SC SE SF B C E [Note1]																																							
⑨ Nipple /adapter type	<table border="1"> <tr> <td rowspan="4">15</td> <td>M4: M4 Nipple</td> <td></td> <td rowspan="2">20</td> <td>M6: M6 Nipple</td> <td></td> <td rowspan="2">45</td> <td>P01: PT1/8 Nipple</td> <td></td> </tr> <tr> <td>AM6: M4 to M6</td> <td>I type </td> <td>A01: M6 to PT1/8</td> <td>I type </td> <td>A01: PT1/8 to PT1/8</td> <td>I type </td> </tr> <tr> <td rowspan="2">LM6: M4 to M6</td> <td rowspan="2">L type </td> <td>25</td> <td>AM8: M6 to M8</td> <td></td> <td>AM8: PT1/8 to M8</td> <td></td> </tr> <tr> <td>30</td> <td>L01: M6 to PT1/8</td> <td>L type </td> <td>L01: PT1/8 to PT1/8</td> <td>L type </td> </tr> <tr> <td>35</td> <td>LM8: M6 to M8</td> <td></td> <td>LM8: PT1/8 to M8</td> <td></td> </tr> <tr> <td></td> <td>SM6: M6 Nipple</td> <td></td> <td></td> <td>SP01: PT1/8 Nipple</td> <td></td> </tr> </table>	15	M4: M4 Nipple		20	M6: M6 Nipple		45	P01: PT1/8 Nipple		AM6: M4 to M6	I type	A01: M6 to PT1/8	I type	A01: PT1/8 to PT1/8	I type	LM6: M4 to M6	L type	25	AM8: M6 to M8		AM8: PT1/8 to M8		30	L01: M6 to PT1/8	L type	L01: PT1/8 to PT1/8	L type	35	LM8: M6 to M8		LM8: PT1/8 to M8			SM6: M6 Nipple			SP01: PT1/8 Nipple		
15	M4: M4 Nipple			20		M6: M6 Nipple			45	P01: PT1/8 Nipple																														
	AM6: M4 to M6		I type		A01: M6 to PT1/8	I type	A01: PT1/8 to PT1/8	I type																																
	LM6: M4 to M6		L type	25	AM8: M6 to M8		AM8: PT1/8 to M8																																	
		30		L01: M6 to PT1/8	L type	L01: PT1/8 to PT1/8	L type																																	
35	LM8: M6 to M8		LM8: PT1/8 to M8																																					
	SM6: M6 Nipple			SP01: PT1/8 Nipple																																				
⑩ Self-lubricator Standard Type	E: Self-lubricator Standard Type																																							

[Note1]: When selecting rails and bearings, the different pairing codes can change the units preload. details see "preload pairing chart".

## LSH Series

### Self-lubricator illustration

#### 1. Code and structure

AirTAC provides self-lubricator for applications e.g. limited spaces, or where grease maintenance is challenging.

If needed, please add the code "E" after the product model.

E.g. LSH15HN1X220S20AH-AM6 - B - T - E

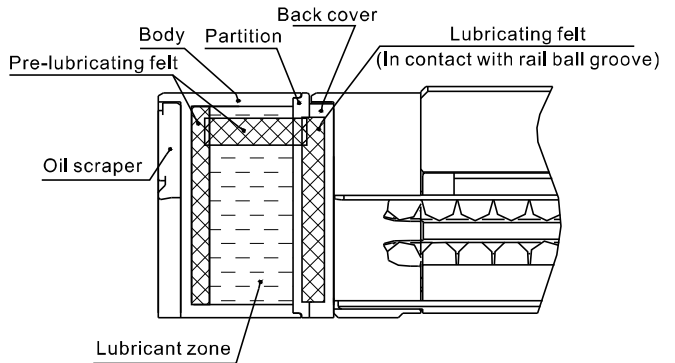
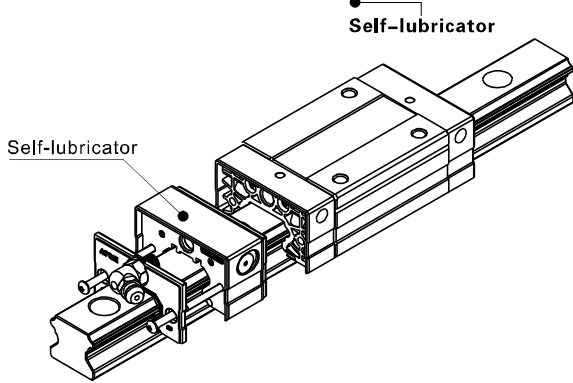

### Product Features

- Easy Maintenance and Long-Term Maintenance-Free Operation:** In normal applications, basically no additional grease maintenance is required throughout lifespan of linear guide.
  - Cost Savings:** No additional lubrication is needed for the block, reducing labor and material costs.
  - Flexible Use in Specific Environments:** Equipped with a high-capacity grease tank, allowing the use of specific lubricants for specific environments.
  - Dustproof Design:** Built-in dustproof structure extends lifespan.
  - Flexible in usage and installation:** the assembling and disassembling of self-lubricator in integrity structure is convenient, can have it according to different working condition.
- [Note] Self-lubricator type block is not applicable for ultra-smooth application, as the higher viscosity of the lubricant in self-lubricator will increase friction by approximately 5–7%.

#### Durability test of self-lubricator

Test specification	Test specification	Model	Speed	Stroke	Lubricant type
■	Lubricating effect	LSH20	30m/min	1200mm	ISO VG680 high-quality extreme pressure lubricant

#### ■ Test result

Test result shows that after running 1,000 km, only 20% of the grease is consumed, and the linear guide remains lubricated. The expected service life can possibly exceed 4,000 km.

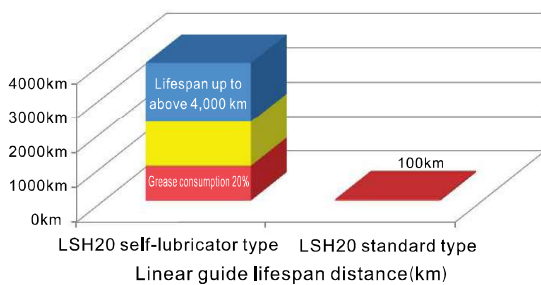

When comparing each sub-series with the self-lubricator and the standard model, the length of block will change. Please refer to the table below for details.

- Block dimension comparison (only dimension C is different from the standard, the rest remains the same)

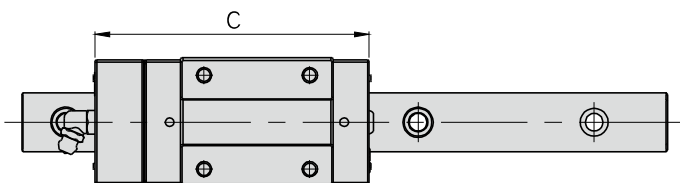

Model	Type	Length C(mm)	
		Standard (Blank)	Self-lubricator Standard Type
LSH15□N	Standard	60	75.5
LSH20□N	Standard	76.5	93.5
LSH20□L	Long	90.5	107.5
LSH25□N	Standard	83.5	100.5
LSH25□L	Long	105	122
LSH30□N	Standard	95.5	112.5
LSH30□L	Long	118	135
LSH35□N	Standard	109	126
LSH35□L	Long	134.5	151.5
LSH45□N	Standard	132	152.5
LSH45□L	Long	164	184.5

### Precautions on use

#### 1. Block disassembly

With ball retainers and a dustproof cover, normally the balls are prevented from falling out when block is removed from rail. However, if obliquely insert rail into blocks or quickly assembled or disassembled, there is a risk for balls of falling out. Please carefully assemble the linear guide or use plastic rails to assist.

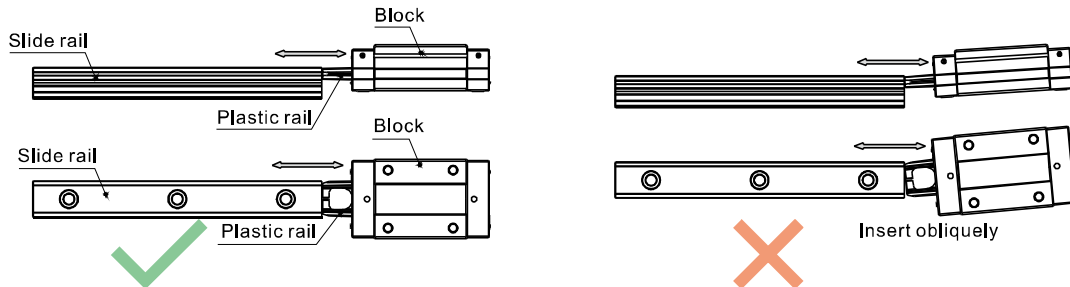

#### 2. Plastic rail installation

A plastic rail is equipped for individual block set. Please do not remove plastic rail whenever it is not necessary.

If plastic rail falls out and needs to be reinstalled, press the dustproof covers with fingers and install slowly to prevent balls from falling out due to misalignment of plastic rail.

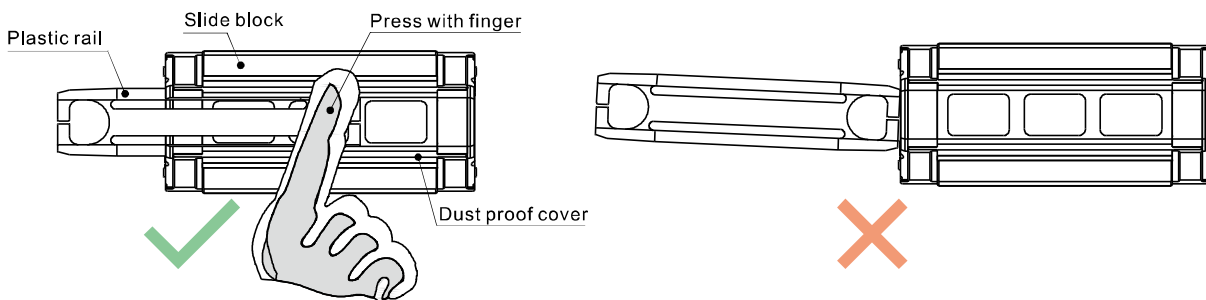

Press the dust-proof covers and insert plastic rail in alignment.

Without pressing dust-proof covers or insert plastic rail obliquely.

#### 3. Caution

- Parts may slide out if linear guide is put unevenly. Please be careful.
- Hitting or dropping linear guide could have huge effect on accuracy and lifespan even though appearance may remain intact. Please be careful.
- Do not disassemble linear guide as external objects may enter blocks and cause accuracy problem.

#### 4. Lubrication

- Linear guide have been treated with anti-rust oil during production. Before use, wipe the rail and treat it with lubrication.
- Do not mix lubricating oil (grease) with different properties.
- After lubrication, move block back and forth for the length of three blocks long and repeat at least 2 times to ensure there is a grease file on rail.

#### 5. Use

- The operating environment temperature should not exceed 80°C, and the maximum temperature should not exceed 100°C.
- Do not separate blocks from rail whenever it is not necessary. If you need to separate them, please use plastic rails to prevent steel balls from falling out.

#### 6. Storage

- When storing blocks, rails or linear guide set, please be sure that anti-rust oil is well applied and product is well sealed as well as placed horizontally. Avoid humidity and high temperatures environment.