

4GA/B
M4GA/B
MN4GA/B
4GA/B (master)
4GB With sensor
4GD/E
M4GD/E
MN4GD/E
4GA4/B4
MN3E
MN4E
W4GA/B2
W4GB4
MN3S0
MN4S0
4SA/B0
4KA/B
4KA/B (master)
4F
4F (master)
PV5G
GMF
PV5
GMF
PV5S-0
3Q
MV3QR
3MA/B0
3PA/B
P/M/B
NP/NAP
NVP
4G*0EJ
4F*0EX
4F*0E
HMV
HSV
2QV
3QV
SKH
Silencer
TotAirSys (Total Air)
TotAirSys (Gamma)
Ending

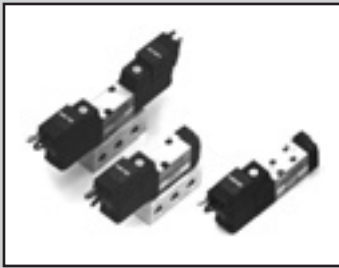

Single unit
Pilot operated 5-port valve/small pneumatic valve
Body piping/sub-plate piping

4SA0/4SB0 Series

● Cylinder bore size: $\varnothing 6$ to $\varnothing 25$

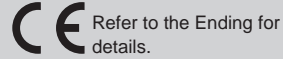

JIS symbol

● 5-port valve
2 position single

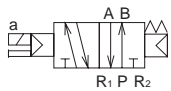

2-position double



3-position
All ports closed

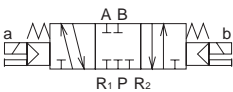

3-position A/B/R connection



3-position P/A/B connection



Common specifications

Item	Description
Valve and operation	Pilot operated soft spool valve
Working fluid	Compressed air
Max. working pressure MPa	0.7
Min. working pressure MPa	0.2
Proof pressure MPa	1.05
Ambient temperature °C	5 to 50
Fluid temperature °C	5 to 50
Lubrication	Not required
Degree of protection	Dust-proof
Vibration resistance m/s^2	50 or less
Shock resistance m/s^2	300 or less
Atmosphere	Cannot be used in corrosive gas environment.

*1: 4SA0 is a pilot atmosphere release type. The pilot exhaust for 4SB0 is centralized with port R.

Electrical specifications

Item	Description	
Rated voltage V	24 DC	12 DC
Voltage fluctuation range	$\pm 10\%$	
Holding current A	0.025 (*2) (0.029)	0.050 (0.058)
Power consumption W (*3)	0.6 (0.7)	0.6 (0.7)
Thermal class	B	
Temperature rise °C	50	

*2: () The values in are with a surge suppressor and indicator lamp.

*3: The power consumption for the 6/5 VDC will be 0.9 (1.0) W. The power consumption for ozone-proof specifications (P11) will be 0.9 (1.0) W.

Individual specifications

Item	Port P/A/B	4SA0		4SB0
		Port size	M3	$\varnothing 4$ barbed fitting
	R ₁ /R ₂ Port	M3		M5

Performance/characteristics by model

Item	4SA0		4SB0	
Response time	2-position	20 or less		
(*4) ms	3-position	30 or less		

*4: The response times are values with supply pressure of 0.5 MPa, without lubrication, and with the power ON. They depend on the pressure and the lubricant quality.

Weight

Item	4SA0		4SB0	
Weight g	2-position	Single	23	43
		Double	35	55
	3-position	39	59	

Flow characteristics

Model No.	Solenoid position	Port size	P → A/B		A/B → R		S (mm ²)	
			C (dm ³ /(sbar))	b	C (dm ³ /(sbar))	b		
4SA0	2-position	Port P/A/B: M3/ $\varnothing 4$ barbed fitting R ₁ /R ₂ Port: M3	-	-	-	-	0.9	
	3-position		All ports closed	-	-	-		
			A/B/R connection	-	-	-		
			P/A/B connection	-	-	-		
4SB0	2-position	M5	0.32	0.20	0.30	0.21	-	
	3-position		All ports closed	0.32	0.19	0.29	0.11	-
			A/B/R connection	0.31	0.18	0.29	0.22	-
			P/A/B connection	0.33	0.20	0.29	0.21	-

*5: Effective cross-sectional area S and sonic conductance C are converted as $S = 5.0 \times C$.

Ozone-proof specifications (Ending Page 5)

CE marking specifications

** - Voltage - **P11**

** - Voltage - **ST**

• Standard voltage of 24 VDC or less is CE marking-compatible even if the model No. is not indicated with "ST".

How to order discrete valve

4SA0 1 0 - M3 - M1 C2 - 3

● Single solenoid valve for manifold (body piping)

4SA0 1 9 - M3 - M1 C2 - 3

● Single solenoid valve for manifold (sub-plate piping)

4SB0 1 9 - 00 - M1 C2 - 3

A Model No.

Fixed code

B Solenoid position

C Port size

D Manual override

E Electrical connections (*3)

Note: Refer to page 1234 for the circuit diagram with a surge suppressor/lamp.

⚠ Precautions for model No. selection

*1: The CKD compatible fittings of M3 are as listed below.

FTS4-M3, GWS3-M3-S

*2: For T4, barbed fitting FTS4-M3 screws into the A/B-port.

*3: The lead wire used is AWG26 size. (7/0.16, outer diameter ϕ 1.35, 0.13 mm²)

*4: C4 and D4 are only single solenoid valves for 4SB0 manifolds. A reduced wiring socket assembly (length of 270 mm) will be attached.

[Example of model No.]

4SA010-M3-M1P-3

A Model: 4SA0

B Solenoid position : 2-position single

C Port size : M3

D Manual override : Locking manual override

E Electrical connections: Grommet lead wire (standard)

F Other options : Mounting plate

G Voltage : 24 VDC

F Other options

G Voltage

A Model No.	
Body piping	Sub-plate piping
4SA0	4SB0

Code	Description	4SA0	4SB0
B Solenoid position			
1	2-position single	●	●
2	2-position double	●	●
3	3-position all ports closed	●	●
4	3-position A/B/R connection	●	●
5	3-position P/A/B connection	●	●
C Port size			
Port	P/A/B	R ₁ /R ₂	
M3	M3		● (*1)
M5	M5		●
T4	ϕ 4 Barbed fitting	M3	● (*2)
D Manual override			
Blank	Non-locking manual override	●	●
M1	Locking manual override	●	●
E Electrical connections			
Grommet lead wire			
Blank	Grommet lead wire (300 mm)	●	●
C-connector (lead wire lateral direction)			
C	Lead wire (300 mm)	●	●
C00	Lead wire (500 mm)	●	●
C01	Lead wire (1000 mm)	●	●
C02	Lead wire (2000 mm)	●	●
C1	Without lead wire (with socket)	●	●
C2	Lead wire (300 mm), surge suppressor/indicator lamp	●	●
C20	Lead wire (500 mm), surge suppressor/indicator lamp	●	●
C21	Lead wire (1000 mm), surge suppressor/indicator lamp	●	●
C22	Lead wire (2000 mm), surge suppressor/indicator lamp	●	●
C2N	No lead wire (without socket), surge suppressor/indicator lamp	●	●
C3	No lead wire (with socket), surge suppressor/indicator lamp	●	●
C4	With surge suppressor/lamp (for T31/T50) (*4)	●	●
D-connector (lead wire upward direction)			
D	Lead wire (300 mm)	●	●
D00	Lead wire (500 mm)	●	●
D01	Lead wire (1000 mm)	●	●
D02	Lead wire (2000 mm)	●	●
D1	Without lead wire (with socket)	●	●
D2	Lead wire (300 mm), surge suppressor/indicator lamp	●	●
D20	Lead wire (500 mm), surge suppressor/indicator lamp	●	●
D21	Lead wire (1000 mm), surge suppressor/indicator lamp	●	●
D22	Lead wire (2000 mm), surge suppressor/indicator lamp	●	●
D2N	No lead wire (without socket), surge suppressor/indicator lamp	●	●
D3	No lead wire (with socket), surge suppressor/indicator lamp	●	●
D4	With surge suppressor/lamp (T30) (*4)	●	●
F Other options			
Blank	Without mounting plate	●	●
P	Mounting plate (compatible only with 2-position single)	●	●
G Voltage			
3	Standard	24 VDC	●
4		12 VDC	●
DC6V	Option	6 VDC	●
DC5V		5 VDC	●

- 4GA/B
- M4GA/B
- MN4GA/B
- 4GA/B (master)
- 4GB With sensor
- 4GD/E
- M4GD/E
- MN4GD/E
- 4GA4/B4
- MN3E
- MN4E
- W4GA/B2
- W4GB4
- MN3S0
- MN4S0
- 4SA/B0
- 4KA/B
- 4KA/B (master)
- 4F
- 4F (master)
- PV5G
- GMF
- PV5
- GMF
- PV5S-0
- 3Q
- MV3QR
- 3MA/B0
- 3PA/B
- P/M/B
- NP/NAP
- NVP
- 4G*0EJ
- 4F*0EX
- 4F*0E
- HMV
- HSV
- 2QV
- 3QV
- SKH
- Silencer
- TotAirSys (Total Air)
- TotAirSys (Gamma)
- Ending

4SA0 Series

Discrete valve; body piping

Internal structure and parts list

- 4GA/B
- M4GA/B
- MN4GA/B
- 4GA/B (master)
- 4GB With sensor
- 4GD/E
- M4GD/E
- MN4GD/E
- 4GA4/B4
- MN3E
- MN4E
- 4SA/B0
- 4KA/B
- 4KA/B (master)
- 4F
- 4F (master)
- PV5G
- GMF
- PV5
- GMF
- PV5S-0
- 3Q
- MV3QR
- 3MA/B0
- 3PA/B
- P/M/B
- NP/NAP
- NVP
- 4G*0EJ
- 4F*0EX
- 4F*0E
- HMV
- HSV
- 2QV
- 3QV
- SKH
- Silencer
- TotAirSys (Total Air)
- TotAirSys (Gamma)
- Ending

4SA010

● 2-position single

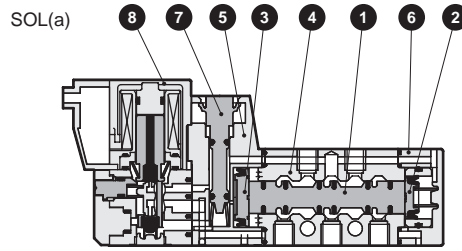
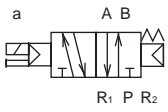

4SA020

● 2-position double

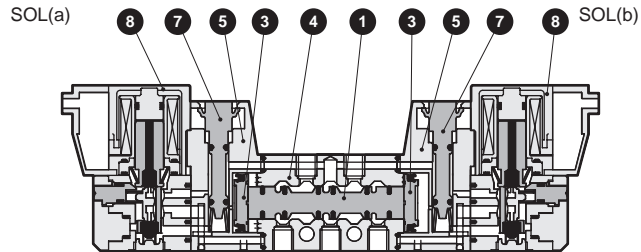
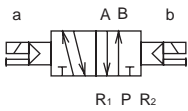

4SA030

● 3-position

All ports closed

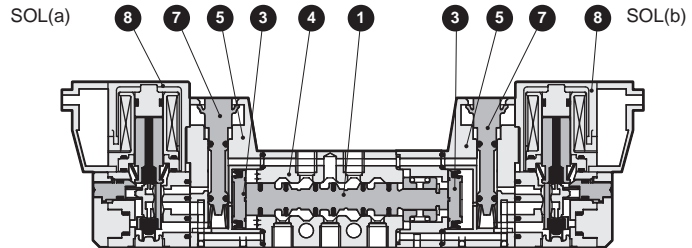
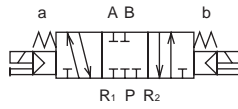

4SA040

A/B/R connection

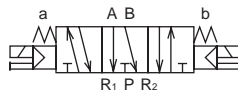

4SA050

P/A/B connection



Main parts list

No.	Part name	Material
1	Spool assembly	-
2	Piston S assembly	-
3	Piston D assembly	-
4	Body	Aluminum
5	Piston chamber	Resin
6	Cap	Resin
7	Manual override	Resin
8	Coil assembly	-

Parts list

No.	Part name	Model No.
8	Coil assembly	4S0 - [electrical connections] - COIL - [voltage] ↑ Blank for grommet lead wire

Internal structure and parts list

4SB010

● 2-position single

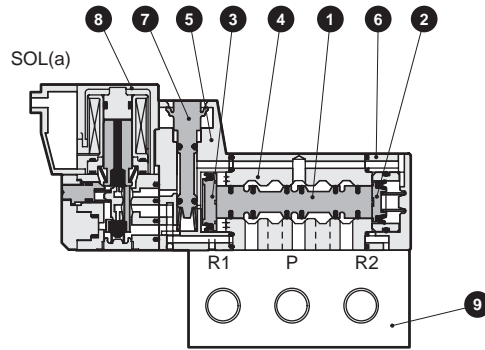
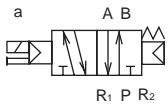

4SB020

● 2-position double

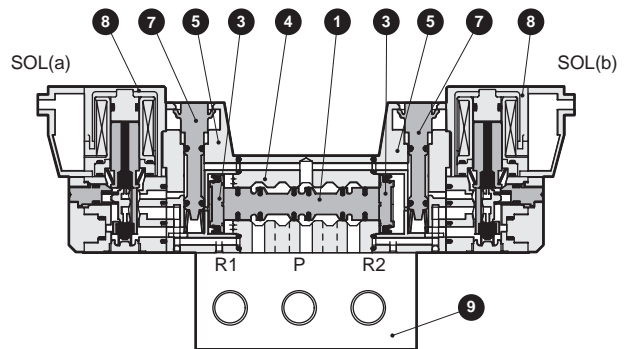
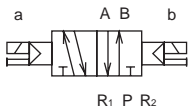

4SB030

● 3-position

All ports closed

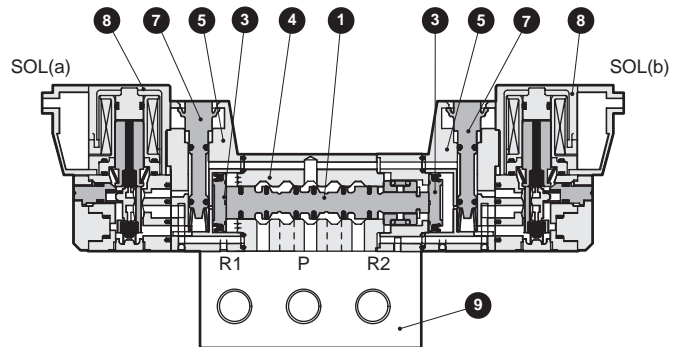
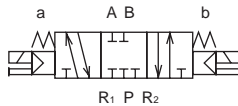

4SB040

A/B/R connection



4SB050

P/A/B connection



Main parts list

No.	Part name	Material
1	Spool assembly	-
2	Piston S assembly	-
3	Piston D assembly	-
4	Body	Aluminum
5	Piston chamber	Resin
6	Cap	Resin
7	Manual override	Resin
8	Coil assembly	-
9	Sub-plate	Aluminum

Parts list

No.	Part name	Model No.
8	Coil assembly	4S0 - [electrical connections] - COIL - [voltage] ↑ Blank for grommet lead wire

4GA/B
M4GA/B
MN4GA/B
4GA/B (master)
4GB With sensor
4GD/E
M4GD/E
MN4GD/E
4GA4/B4
MN3E
MN4E
W4GA/B2
W4GB4
MN3S0
MN4S0
4SA/B0
4KA/B
4KA/B (master)
4F
4F (master)
PV5G
GMF
PV5
GMF
PV5S-0
3Q
MV3QR
3MA/B0
3PA/B
P/M/B
NP/NAP
NVP
4G*0EJ
4F*0EX
4F*0E
HMV
HSV
2QV
3QV
SKH
Silencer
TotAirSys (Total Air)
TotAirSys (Gamma)
Ending

4SA0 Series

Discrete valve; body piping

Dimensions

4GA/B
M4GA/B
MN4GA/B
4GA/B (master)
4GB With sensor
4GD/E
M4GD/E
MN4GD/E
4GA4/B4
MN3E
MN4E
W4GA/B2
W4GB4
MN3S0
MN4S0
4SA/B0
4KA/B
4KA/B (master)
4F
4F (master)
PV5G
GMF
PV5
GMF
PV5S-0
3Q
MV3QR
3MA/B0
3PA/B
P/M/B
NP/NAP
NVP
4G*0EJ
4F*0EX
4F*0E
HMV
HSV
2QV
3QV
SKH
Silencer
TotAirSys (Total Air)
TotAirSys (Gamma)
Ending

4SA010-M3



● 2-position single: grommet lead wire

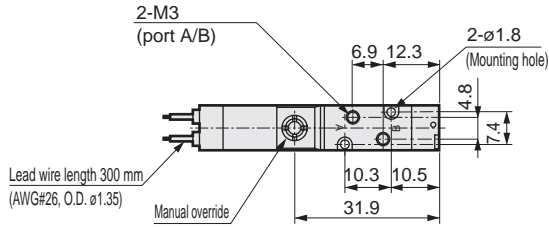

Lead wire length 300 mm (AWG#26, O.D. ϕ 1.35)

4SA020-M3



● 2-position double: grommet lead wire

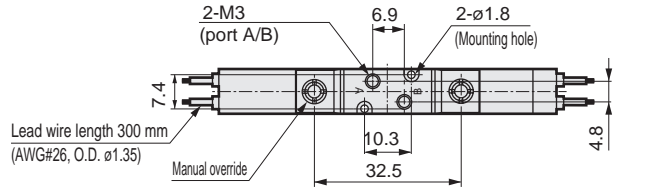

Lead wire length 300 mm (AWG#26, O.D. ϕ 1.35)

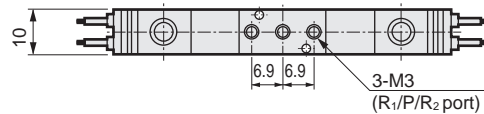
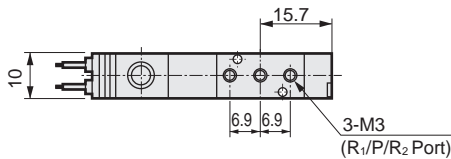
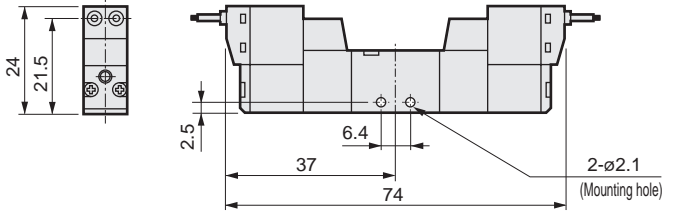
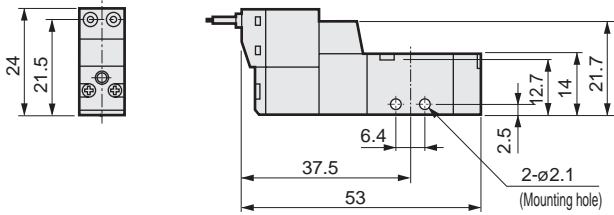

● Mounting plate: P (2-position single only)

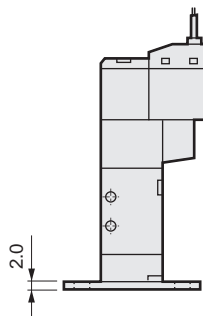
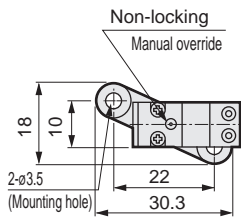

4SA030-M3



● 3-position: grommet lead wire

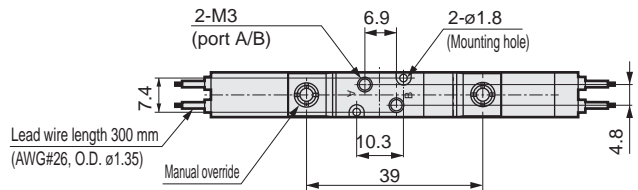

Lead wire length 300 mm (AWG#26, O.D. ϕ 1.35)

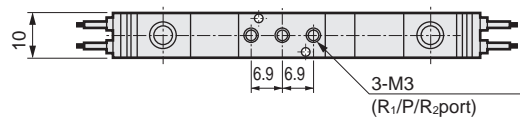
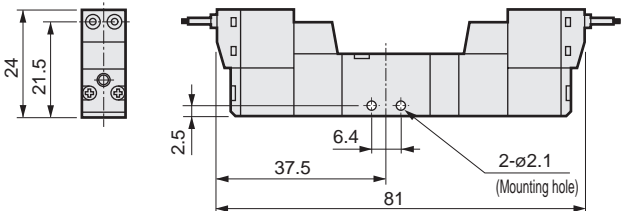

Dimensions

● $\varnothing 4$ barbed fitting: (T4)

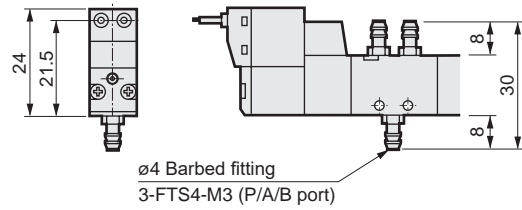

● Locking manual override: (M1)

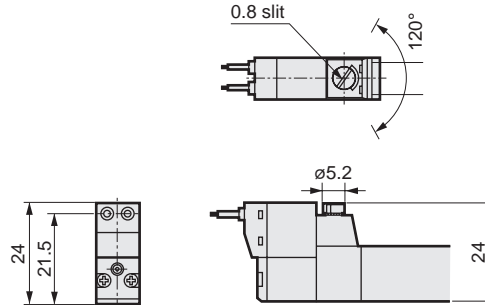

● C-connector: (C/C0*/C1/C2/C2*/C3)

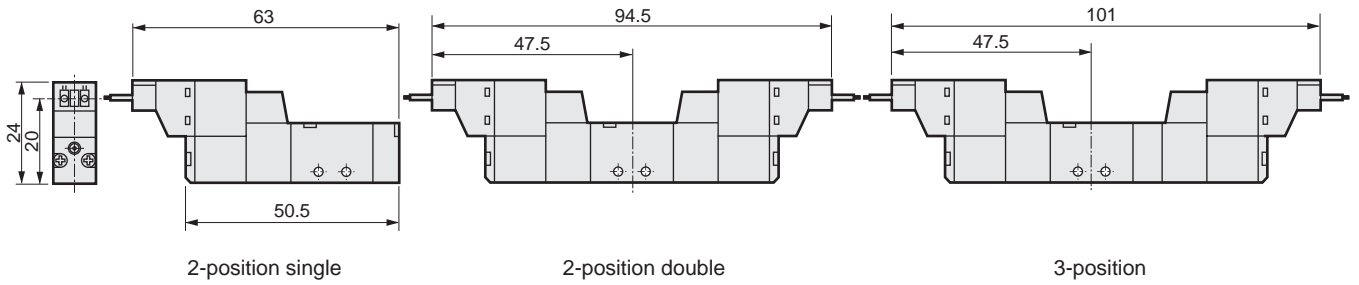

● D-connector: (D/D0*/D1/D2/D2*/D3)

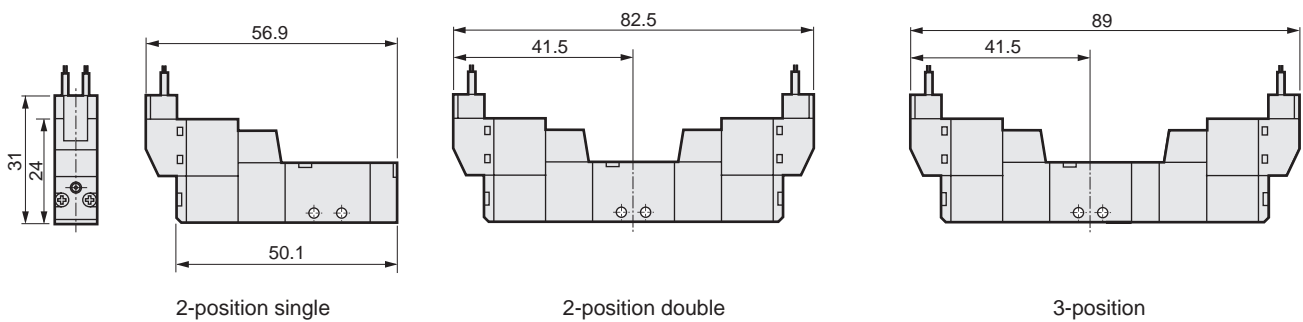

4GA/B

M4GA/B

MN4GA/B

4GA/B

(master)

4GB

With sensor

4GD/E

M4GD/E

MN4GD/E

4GA4/B4

MN3E

MN4E

W4GA/B2

W4GB4

MN3S0

MN4S0

4SA/B0

4KA/B

4KA/B

(master)

4F

4F

(master)

PV5G

GMF

PV5

GMF

PV5S-0

3Q

MV3QR

3MA/B0

3PA/B

P/M/B

NP/NAP

NVP

4G*0EJ

4F*0EX

4F*0E

HMV

HSV

2QV

3QV

SKH

Silencer

TotAirSys

(Total Air)

TotAirSys

(Gamma)

Ending

4SB0 Series

Discrete valve; sub-plate piping

Dimensions 

4GA/B
M4GA/B
MN4GA/B
4GA/B (master)
4GB With sensor
4GD/E
M4GD/E
MN4GD/E
4GA4/B4
MN3E
MN4E
W4GA/B2
W4GB4
MN3S0
MN4S0
4SA/B0
4KA/B
4KA/B (master)
4F
4F (master)
PV5G
GMF
PV5
GMF
PV5S-0
3Q
MV3QR
3MA/B0
3PA/B
P/M/B
NP/NAP
NVP
4G*0EJ
4F*0EX
4F*0E
HMV
HSV
2QV
3QV
SKH
Silencer
TotAirSys (Total Air)
TotAirSys (Gamma)
Ending

4SB010-M5

● 2-position single: grommet lead wire

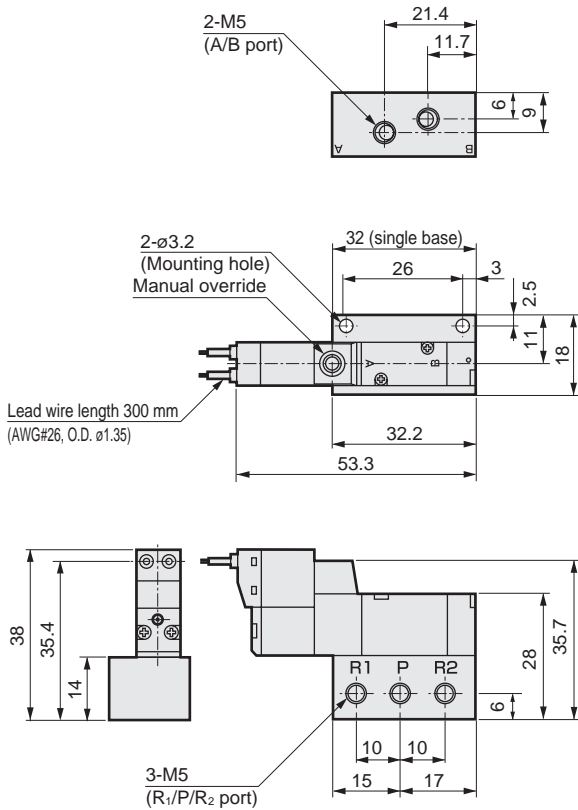

4SB020-M5

● 2-position double: grommet lead wire

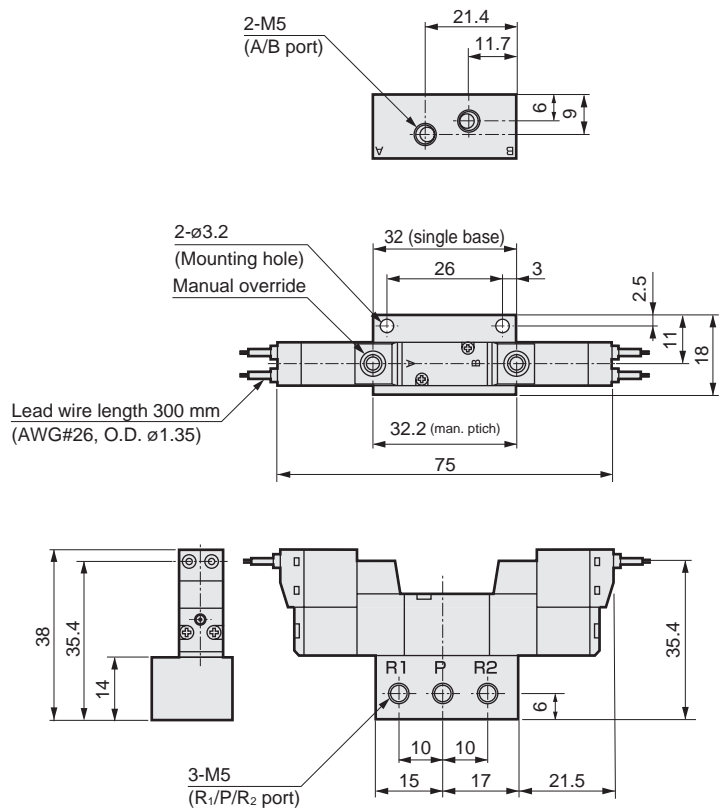

4SB0³/₄/₅0-M5

● 3-position: grommet lead wire

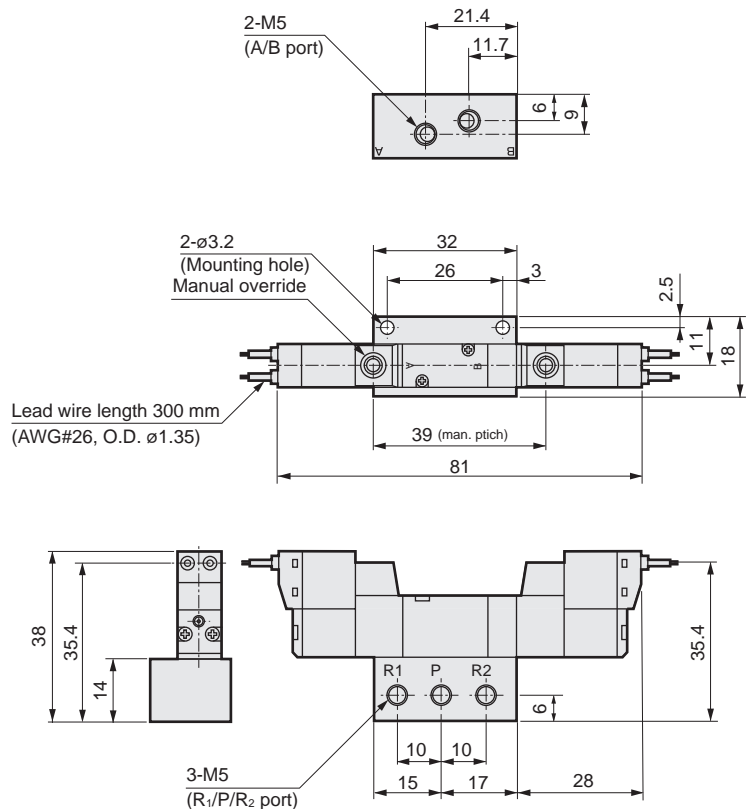

Dimensions

- Locking manual override: (M1)

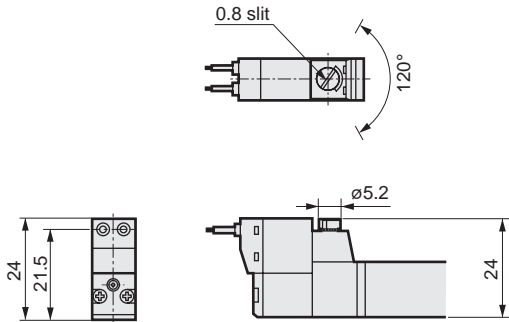

- C-connector: (C/C0*/C1/C2/C2*/C3)

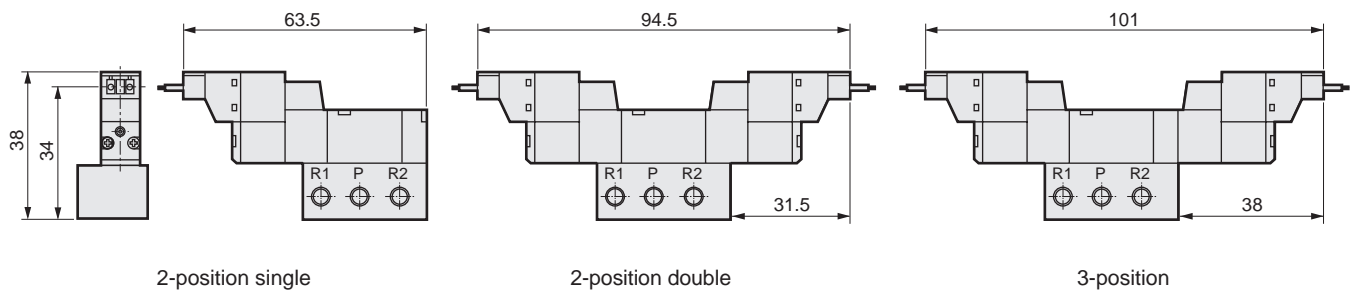

- D-connector: (D/D0*/D1/D2/D2*/D3)

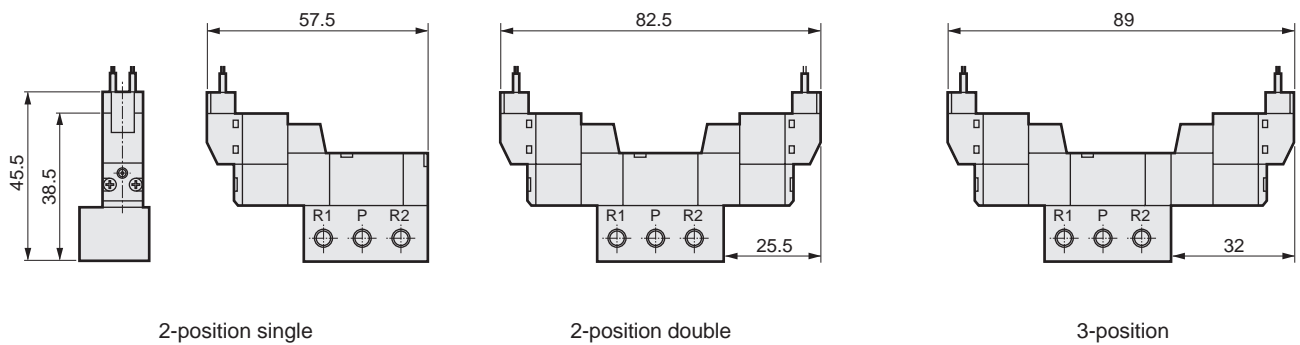

4GA/B
M4GA/B
MN4GA/B
4GA/B (master)
4GB With sensor
4GD/E
M4GD/E
MN4GD/E
4GA4/B4
MN3E MN4E
W4GA/B2
W4GB4
MN3S0 MN4S0
4SA/B0
4KA/B
4KA/B (master)
4F
4F (master)
PV5G GMF
PV5 GMF
PV5S-0
3Q
MV3QR
3MA/B0
3PA/B
P/M/B
NP/NAP NVP
4G*0EJ
4F*0EX
4F*0E
HMV HSV
2QV 3QV
SKH
Silencer
TotAirSys (Total Air)
TotAirSys (Gamma)
Ending

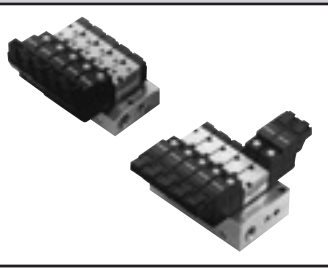

Individual wiring manifold,
Pilot operated 5-port valve/small pneumatic valve
Body piping/sub-plate piping

M4SA0/M4SB0 Series

● Cylinder bore size: $\varnothing 6$ to $\varnothing 25$

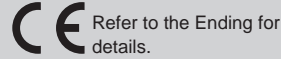

- 4GA/B
- M4GA/B
- MN4GA/B
- 4GA/B (master)
- 4GB With sensor
- 4GD/E
- M4GD/E
- MN4GD/E
- 4GA4/B4
- MN3E MN4E
- W4GA/B2
- W4GB4
- MN3S0 MN4S0
- 4SA/B0**
- 4KA/B
- 4KA/B (master)
- 4F
- 4F (master)
- PV5G GMF
- PV5 GMF
- PV5S-0
- 3Q
- MV3QR
- 3MA/B0
- 3PA/B
- P/M/B
- NP/NAP NVP
- 4G*0EJ
- 4F*0EX
- 4F*0E
- HMV HSV
- 2QV 3QV
- SKH
- Silencer
- TotAirSys (Total Air)
- TotAirSys (Gamma)
- Ending

JIS symbol

- 5-port valve
2-position single

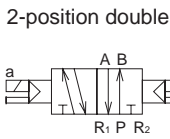
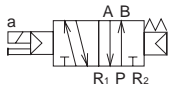

- 3-position all ports closed

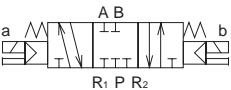

- 3-position A/B/R connection

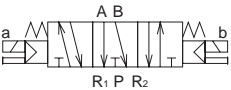

- 3-position P/A/B connection

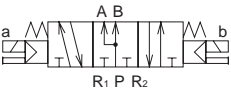

Common specifications

Item	Description
Manifold method	Manifold integrated
Manifold	Common supply, common exhaust (*1)
Station No.	2 to 20 stations
Valve and operation	Pilot operated soft spool valve
Working fluid	Compressed air
Max. working pressure MPa	0.7 (≈ 100 psi, 7 bar)
Min. working pressure MPa	0.2 (≈ 29 psi, 2 bar)
Proof pressure MPa	1.05 (≈ 150 psi, 10.5 bar)
Ambient temperature $^{\circ}\text{C}$	5 (41 $^{\circ}\text{F}$) to 50 (122 $^{\circ}\text{F}$)
Fluid temperature $^{\circ}\text{C}$	5 (41 $^{\circ}\text{F}$) to 50 (122 $^{\circ}\text{F}$)
Lubrication	Not required
Degree of protection	Dust-proof
Vibration resistance m/s^2	50 or less
Shock resistance m/s^2	300 or less
Atmosphere	Cannot be used in corrosive gas environment.

Electrical specifications

Item	Description	
Rated voltage V	24 DC	12 DC
Voltage fluctuation range	$\pm 10\%$	
Holding current A	0.025 (*2) (0.029)	0.050 (0.058)
Power consumption W (*3)	0.6(0.7)	0.6(0.7)
Thermal class	B	
Temperature rise $^{\circ}\text{C}$	50	

- *1: 4SA0 is a pilot atmosphere release.
The pilot exhaust for 4SB0 is centralized with the R-port.
- *2: The values in () are with a surge suppressor and indicator lamp.
- *3: The power consumption for 6/5 VDC will be 0.9 (1.0) W.
The power consumption for ozone-proof specifications (P11) will be 0.9 (1.0) W.

Individual specifications

Item		M4SA0	M4SB0
Port size (*4)	P-port	M5	M5/Rc1/8
	A/B-port	M3	M5
	R-port	Rc1/8	
Manifold base weight calculation formula (n: station No.)	P-port: M5	13n+18	20n+36
	g P-port: Rc1/8		21n+26

- *4: For the port size of P and A/B-ports, there are options other than those listed above.
Refer to item ● in How to order on the next page.

Performance/characteristics by model

Item	M4SA0	M4SB0
Response time	2-position	20 or less
(*5) ms	3-position	30 or less

- *5: The response time is the value at 0.5 MPa supply pressure, with no lubrication, and with the power ON. It depends on the pressure and the lubricant quality.

Flow characteristics

Model No.	Solenoid position	Port size	P→A/B		A/B→R	
			$C[\text{dm}^3/(\text{s}\cdot\text{bar})]$	b	$C[\text{dm}^3/(\text{s}\cdot\text{bar})]$	b
M4SA0	2-position	P-port: M5, A/B-port: M3	-	-	-	-
	3-position	R-port: Rc1/8	-	-	-	-
M4SB0	2-position	P-port: M5/Rc1/8	0.30	0.15	0.30	0.21
	3-position	A/B-port: M5, R-port: Rc1/8	0.29	0.14	0.30	0.20

- *6: Be careful when using the T4 specifications ($\varnothing 4$ barbed fitting use) as the flow rate will be constricted depending on the effective cross-sectional area of the fitting.

- *7: Effective cross-sectional area S and sonic conductance C are converted as $S \approx 5.0 \times C$.

Example

[Mix manifold]

- How to list combination descriptions
When selecting a combination manifold (write 8 from ●), list the code (refer to table at right) for required functions and the arrangement No. (numbering up to specified station No. with left side as 1) in the field for remarks below the normal model No. display as shown in the example.

Code	Function
S1	2-position single
S2	2-position double
S3	3-position all ports closed
S4	3-position A/B/R connection
S5	3-position P/A/B connection
MP	Masking plate

1	2	3	4	5	6	7
2-position Single (S1)	2-position Double (S2)	3-position All ports closed (S3)	3-position All ports closed (S3)	2-position Double (S2)	2-position Single (S1)	3-position A/B/R connection (S4)

The model No. when using a combination manifold of 7 stations with an array such as that in the figure at left with the A/B/P-ports of M5 and 24 VDC is
M4SB080-M5-C02-7-3-222100
S1=1.6 S2=2.5 S3=3.4 S4=7
Code Position

- With a mix manifold, when using 10 or more actuators of the same model No., specify using the codes in the table below.

Actuator quantity	10	11	12	13	14	15	16	17	18	19
Code	A	B	C	D	E	F	G	H	I	J

S1	S2	S3	S4	S5	MP
2	2	2	1	0	0

M4SA0/M4SB0 Series

Individual wiring manifold

How to order individual wiring manifold

- Single solenoid valve for manifold (body piping)



- Single solenoid valve for manifold (sub-plate piping)



- Individual wiring manifolds



A Model No.

Fixed code

B Solenoid position

C Port size

D Manual override

E Electrical connections

Note: Refer to page 1234 for the circuit diagram with a surge suppressor/lamp.

F Station No.

G Voltage

Indicate the valve function based quantity display position when using a mix manifold. Refer to page 1244.

A Model No.	
Body piping	Sub-plate piping
4SA0	4SB0

Code	Description		
B Solenoid position			
1	2 position single	●	●
2	2-position double	●	●
3	3-position all ports closed	●	●
4	3-position A/B/R connection	●	●
5	3-position P/A/B connection	●	●
8	Mix manifold (when there are multiple solenoid positions)	●	●

C Port size				
Port	A/B	P	R	
M3	M 3			●(*1)
M5	M 5			●
GS4	ø4 push-in fitting	M 5	Rc 1/8	●(*3)
T4	ø4 barbed fitting			●(*2)
T6	ø6 barbed fitting			●(*4)
PM5	M 5			●
PGS4	ø4 push-in fitting	Rc 1/8	Rc 1/8	●(*3)
PT4	ø4 barbed fitting			●(*4)
PT6	ø6 barbed fitting			●(*4)

D Manual override			
Blank	Manual override of non-locking	●	●
M1	Locking manual override	●	●

E Electrical connections			
Grommet lead wire			
Blank	Grommet lead wire (300 mm)	●	●

C-connector (lead wire lateral direction)			
C	Lead wire (300 mm)	●	●
C00	Lead wire (500 mm)	●	●
C01	Lead wire (1000 mm)	●	●
C02	Lead wire (2000 mm)	●	●
C1	Without lead wire (with socket)	●	●
C2	Lead wire (300 mm) with surge suppressor and indicator lamp	●	●
C20	Lead wire (500 mm) with surge suppressor and indicator lamp	●	●
C21	Lead wire (1000 mm) with surge suppressor and indicator lamp	●	●
C22	Lead wire (2000 mm) with surge suppressor and indicator lamp	●	●
C2N	Lead wireand(Without socket) with surge suppressor and indicator lamp	●	●
C3	Lead wireand(With socket) with surge suppressor and indicator lamp	●	●

D-connector (lead wire upward direction)			
D	Lead wire (300 mm)	●	●
D00	Lead wire (500 mm)	●	●
D01	Lead wire (1000 mm)	●	●
D02	Lead wire (2000 mm)	●	●
D1	Without lead wire (with socket)	●	●
D2	Lead wire (300 mm) with surge suppressor and indicator lamp	●	●
D20	Lead wire (500 mm) with surge suppressor and indicator lamp	●	●
D21	Lead wire (1000 mm) with surge suppressor and indicator lamp	●	●
D22	Lead wire (2000 mm) with surge suppressor and indicator lamp	●	●
D2N	Lead wireand(Without socket) with surge suppressor and indicator lamp	●	●
D3	Lead wireand(With socket) with surge suppressor and indicator lamp	●	●

F Station No.			
2 to 20	2 to 20 stations	●	●

G Voltage			
3	Standard	24 VDC	●
4	Standard	12 VDC	●
DC6V	Option	6 VDC	●
DC5V	Option	5 VDC	●

- Refer to page 1255 for how to order manifold bases and masking plates.

Precautions for model No. selection

For M4SA0

*1: The CKD compatible fittings of M3 are as listed below.

FTS4-M3, GWS3-M3-S

*2: For T4, barbed fitting FTS4-M3 screws into the A/B-port.

For M4SB0

*3: For GS4, push-in fitting GWS4-M5-S screws into the A/B-port.

*4: For T4 and T6, FTS4-M5 and FTS6-M5 screw into the A/B-port.

[Example of model No.]

Individual wiring manifolds

M4SB010-M5-C2-2-3

- A Model No. : M4SB0
- B Solenoid position : 2-position single
- C Port size : A/B/P-port = M5, R-port = Rc1/8
- D Manual override : Non-locking manual override
- E Electrical connections: With C-connector lead wire (300 mm)/with surge suppressor and indicator lamp
- F Station No. : 2 stations
- G Voltage : 24 VDC

Ozone-proof specifications (Ending Page 5)

** - Voltage - P11

CE marking specifications

** - Voltage - ST

- Standard voltage of 24 VDC or less is CE marking-compatible even if the model No. is not indicated with "ST".

- 4GA/B
- M4GA/B
- MN4GA/B
- 4GA/B (master)
- 4GB With sensor
- 4GD/E
- M4GD/E
- MN4GD/E
- 4GA4/B4
- MN3E
- MN4E
- W4GA/B2
- W4GB4
- MN3S0
- MN4S0
- 4SA/B0
- 4KA/B
- 4KA/B (master)
- 4F
- 4F (master)
- PV5G
- GMF
- PV5
- GMF
- PV5S-0
- 3Q
- MV3QR
- 3MA/B0
- 3PA/B
- P/M/B
- NP/NAP
- NVP
- 4G*0EJ
- 4F*0EX
- 4F*0E
- HMV
- HSV
- 2QV
- 3QV
- SKH
- Silencer
- TotAirSys (Total Air)
- TotAirSys (Gamma)
- Ending

M4SA0/M4SB0 Series

Individual wiring manifold; body piping/sub-plate piping

Dimensions

- 4GA/B
- M4GA/B
- MN4GA/B
- 4GA/B (master)
- 4GB With sensor
- 4GD/E
- M4GD/E
- MN4GD/E
- 4GA4/B4
- MN3E
- MN4E
- W4GA/B2
- W4GB4
- MN3S0
- MN4S0
- 4SA/B0**
- 4KA/B
- 4KA/B (master)
- 4F
- 4F (master)
- PV5G
- GMF
- PV5
- GMF
- PV5S-0
- 3Q
- MV3QR
- 3MA/B0
- 3PA/B
- P/M/B
- NP/NAP
- NVP
- 4G*0EJ
- 4F*0EX
- 4F*0E
- HMV
- HSV
- 2QV
- 3QV
- SKH
- Silencer
- TotAirSys (Total Air)
- TotAirSys (Gamma)
- Ending

M4SA0*0-M3

● Body piping A type: grommet lead wire

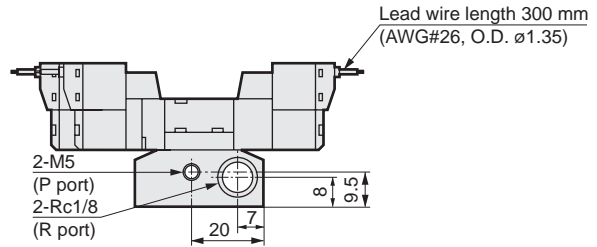
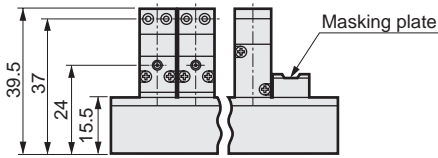
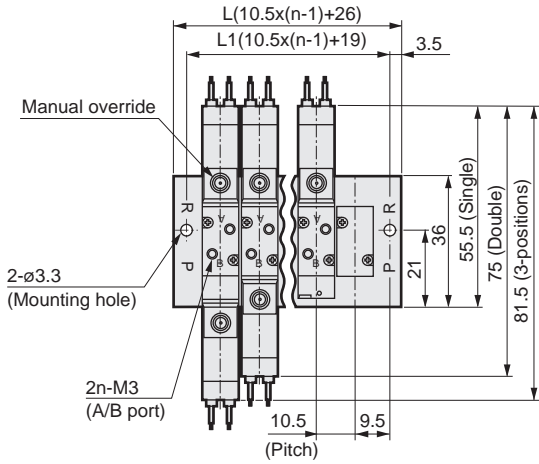

Station No.	2	3	4	5	6	7	8	9	10	11	12	13	14	15	16	17	18	19	20
L1	29.5	40	50.5	61	71.5	82	92.5	103	113.5	124	134.5	145	155.5	166	176.5	187	197.5	208	218.5
L	36.5	47	57.5	68	78.5	89	99.5	110	120.5	131	141.5	152	162.5	173	183.5	194	204.5	215	225.5

M4SB0*0-M5

● Sub-plate piping B type (P port M5): grommet lead wire

● P port Rc1/8

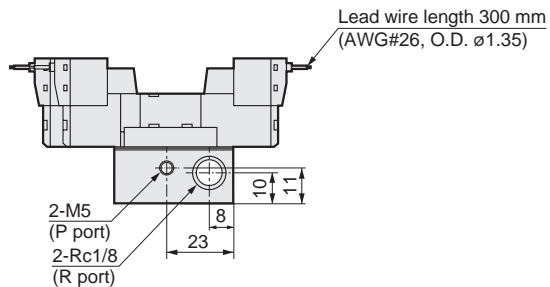
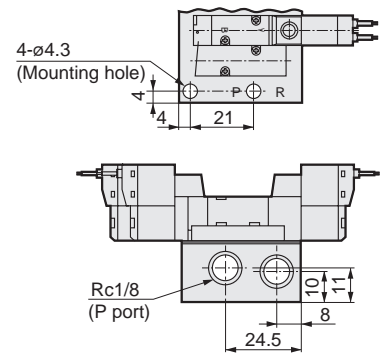
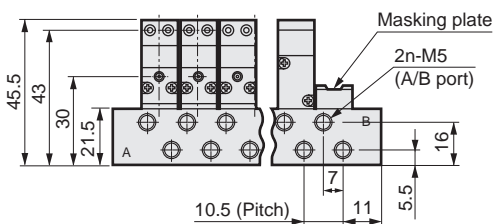
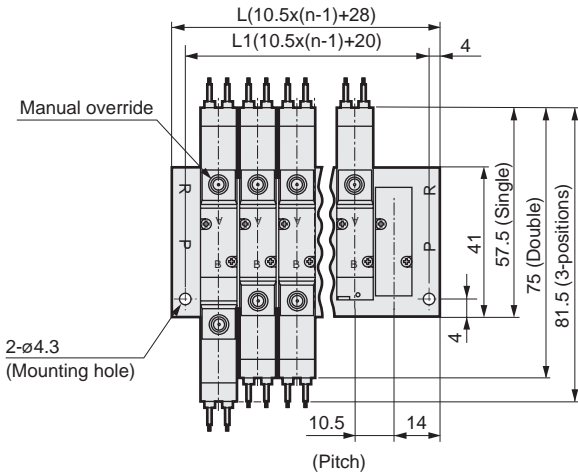

Station No.	2	3	4	5	6	7	8	9	10	11	12	13	14	15	16	17	18	19	20
L1	30.5	41	51.5	62	72.5	83	93.5	104	114.5	125	135.5	146	156.5	167	177.5	188	198.5	209	219.5
L	38.5	49	59.5	70	80.5	91	101.5	112	122.5	133	143.5	154	164.5	175	185.5	196	206.5	217	227.5

M4SA0/M4SB0 Series

Individual wiring manifold; body piping/sub-plate piping

Dimensions

Body piping A type →

● $\phi 4$ barbed fitting: (T4)

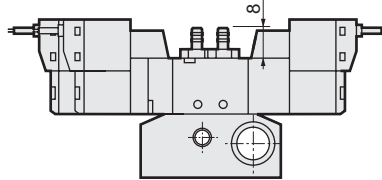

● C-connector:
(C/C0*/C1/C2/C2*/C3)

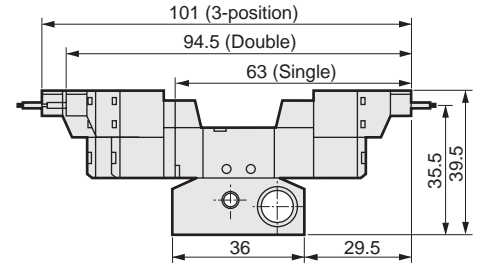

● Locking manual override: (M1)

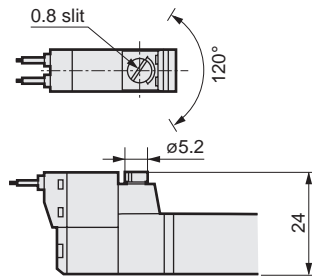

● D-connector:
(D/D0*/D1/D2/D2*/D3)

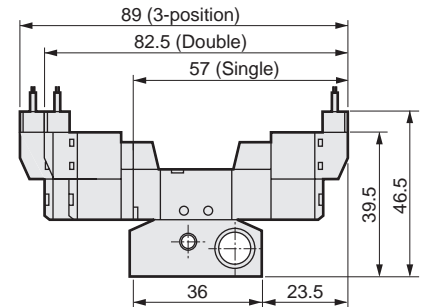

Sub-plate piping B type →

● $\phi 4$ push-in fitting: (GS4/PGS4)

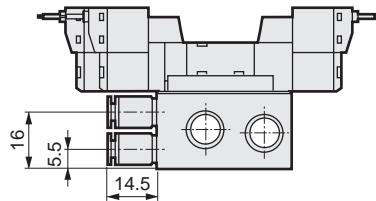

● C-connector:
(C/C0*/C1/C2/C2*/C3)

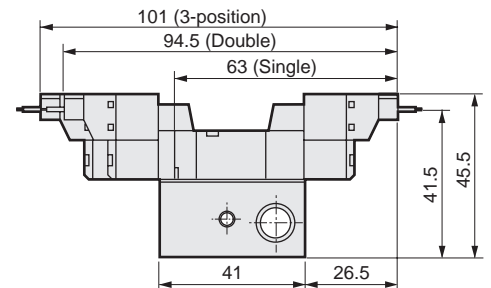

● $\phi 4/\phi 6$ barbed fitting:
(T4/T6/PT4/PT6)

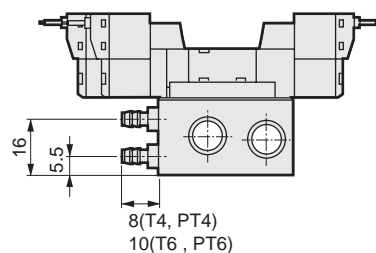

● D-connector:
(D/D0*/D1/D2/D2*/D3)

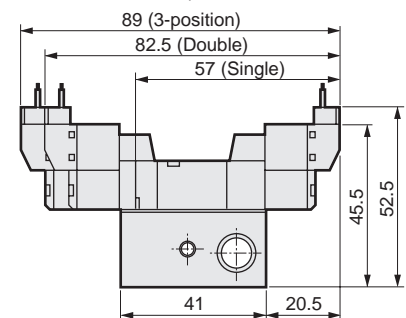

4GA/B
M4GA/B
MN4GA/B
4GA/B (master)
4GB With sensor
4GD/E
M4GD/E
MN4GD/E
4GA4/B4
MN3E
MN4E
W4GA/B2
W4GB4
MN3S0
MN4S0
4SA/B0
4KA/B
4KA/B (master)
4F
4F (master)
PV5G
GMF
PV5
GMF
PV5S-0
3Q
MV3QR
3MA/B0
3PA/B
P/M/B
NP/NAP
NVP
4G*0EJ
4F*0EX
4F*0E
HMV
HSV
2QV
3QV
SKH
Silencer
TotAirSys (Total Air)
TotAirSys (Gamma)
Ending



Reduced wiring manifold
Pilot operated 5-port valve
Sub-plate piping

M4SB0 Series

● Cylinder bore size: $\varnothing 6$ to $\varnothing 25$



JIS symbol

- 5-port valve
2 position single

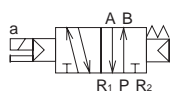

- 2-position double

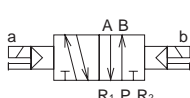

- 3-position
All ports closed

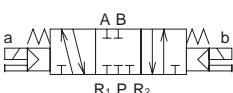

- 3-position A/B/R connection



- 3-position P/A/B connection

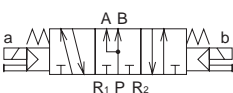

Common specifications

Item	Description
Manifold method	Manifold integrated
Manifold	Common supply, common exhaust*1
Station No.	2 to 20 stations
Valve and operation	Pilot operated soft spool valve
Working fluid	Compressed air
Max. working pressureMPa	0.7
Min. working pressureMPa	0.2
Proof pressure MPa	1.05
Ambient temperature°C	5 to 50
Fluid temperature °C	5 to 50
Lubrication	Not required
Degree of protection	Dust-proof
Vibration resistance m/s^2	50 or less
Shock resistance m/s^2	300 or less
Atmosphere	Cannot be used in corrosive gas environment.

Electrical specifications

Item	Description	
Rated voltage V	24 DC	12 DC
Voltage fluctuation range	$\pm 10\%$	
Holding current A	0.029	0.058
Power consumption W (*2)	0.7	0.7
Thermal class	B	
Temperature rise°C	50	

*1: The pilot exhaust for 4SB0 is centralized with port R.

*2: The power consumption for the 6/5 VDC will be 1.0W. The power consumption for ozone-proof specifications (P11) will be 1.0 W.

Individual specifications

Item	M4SB0	
Port size (*3)	Port P	M5/Rc1/8
	Port A/B	M5
	Port R	Rc1/8
Manifold base	Port P: M5	20n+146
Weight calculation formula (n:Station No.)g	Port P: Rc1/8	21n+136

*3: For the port size of P and A/B-ports, there are options other than those listed above. Refer to item ⑤ of How to order on the next page.

*4: The manifold weight is the value when equipped with wiring section.

Performance/characteristics

Item	M4SB0	
Response time	2-position	20 or less
(*5) ms	3-position	30 or less

*5: The response times are values with supply pressure of 0.5 MPa, without lubrication, and with the power ON. They depend on the pressure and the lubricant quality.

Flow characteristics

Model No.	Solenoid position	Port size	P → A/B		A/B → R	
			C($dm^3/(sbar)$)	b	C($dm^3/(sbar)$)	b
M4SB0	2-position	Port P: M5/Rc1/8	0.30	0.15	0.30	0.21
	3-position	Port A/B: M5, port R: Rc1/8	0.29	0.14	0.30	0.20

*6: Be careful when using the T4 specifications ($\varnothing 4$ barbed fitting use) as the flow rate will be constricted depending on the effective cross-sectional area of the fitting.

*7: Effective cross-sectional area S and sonic conductance C are converted as $S \approx 5.0 \times C$.

[Mix manifold]

- How to list combination descriptions
When selecting a combination manifold (write 8 from ③), list the code (refer to table on right) for required functions and the arrangement No. (numbering up to specified station No. with left side as 1) in the field for remarks below the normal model No. display as shown in the example.

Code	Function
S1	2 position single
S2	2-position double
S3	3-position all ports closed
S4	3-position A/B/R connection
S5	3-position P/A/B connection
MP	Masking plate

1	2	3	4	5	6	7
2-position Single (S1)	2-position Double (S2)	3-position All ports closed (S3)	3-position All ports closed (S3)	2-position Double (S2)	2-position Single (S1)	3-position A/B/R connection (S4)

Example

The model No. when using a combination manifold of 7 stations with an array such as that in the figure at left with the A/B/port Ps of M5 and 24 VDC is **M4SB080-M5-C4T50-7-3-222100**
S1=1,6 S2=2,5 S3=3,4 S4=7
Code Position

- With a mix manifold, when using 10 or more actuators of the same model No., specify using the codes in the table below.

Actuator quantity	10	11	12	13	14	15	16	17	18	19
Code	A	B	C	D	E	F	G	H	I	J

S1	S2	S3	S4	S5	MP
2	2	2	1	0	0

How to order reduced wiring manifold

- Single solenoid valve for manifold (sub-plate piping)

4SB0 1 9 - 00 - M1 C4 ——— 3

- Reduced wiring manifold

M 4SB0 8 0 - M5 - M1 C4T31 - 5 - 3 - 2 2 0 0 0 1

Indicate the valve function based quantity display position when using a mix manifold. Refer to page 1248.

Model No.

Fixed code

A Solenoid position

B Port size

C Manual override

D Electrical connections
Note: Refer to page 1234 for the circuit diagram with a surge suppressor/lamp.

E Station No.

F Voltage

- Refer to page 1255 for how to order manifold bases and masking plates.
- Refer to page 1253 for the model No. of cables with D sub-connector.
- Refer to page 1255 for the model No. of cables for a flat cable connector.

⚠ Precautions for model No. selection

- *1: For GS4, push-in fitting GWS4-M5-S screws into the A/B-port.
- *2: For T4 and T6, FTS4-M5 and FTS6-M5 screw into the A/B-port.
- *3: C4 and D4 are only single solenoid valves for 4SB0 manifolds.
A reduced wiring socket assembly (length of 270 mm) will be attached.
- *4: T30/T31 has a max. number of single solenoids of 20 stations while T50 has a max. number of single solenoids of 16 stations.

[Example of model No.]

● Reduced wiring manifold
M4SB010-M5-C4T50-7-3

Model: M4SB0

- A** Solenoid position : 2-position single
- B** Port size : A/B/P-port = M5,
R-port = Rc1/8
- C** Manual override : Non-locking manual override
- D** Electrical connections: Flat cable connector
- E** Station No. : 7 stations
- F** Voltage : 24 VDC

Code	Description		
A Solenoid position			
1	2 position single		
2	2-position double		
3	3-position all ports closed		
4	3-position A/B/R connection		
5	3-position P/A/B connection		
8	Mix manifold (when there are multiple solenoid positions)		
B Port size			
Port	A/B	P	R
M5	M5	M5	Rc 1/8
GS4	ø4 push-in fitting (*1)		
T4	ø4 barbed fitting (*2)		
T6	ø6 barbed fitting (*2)	Rc 1/8	Rc 1/8
PM5	M5		
PGS4	ø4 push-in fitting (*1)		
PT4	ø4 barbed fitting (*2)		
PT6	ø6 barbed fitting (*2)		
C Manual override			
Blank	Manual override of non-locking		
M1	Locking manual override		
D Electrical connections			
C4	C-connector (for T31/T50) (*3) with surge suppressor and indicator lamp		
D4	D-connector (T30) (*3) with surge suppressor and indicator lamp		
C4T31	D-sub-connector lateral facing type with surge suppressor and indicator lamp		
D4T30	D-sub-connector upward facing type with surge suppressor and indicator lamp		
C4T50	Flat cable connector with surge suppressor and indicator lamp		
E Station No.			
4 to 20	4 to 20 stations (*4)		
F Voltage			
3	Standard	24 VDC	
4		12 VDC	
DC6V	Option	6 VDC	
DC5V		5 VDC	

Ozone-proof specifications (Ending Page 5)

** - Voltage - **P11**

4GA/B
M4GA/B
MN4GA/B
4GA/B (master)
4GB With sensor
4GD/E
M4GD/E
MN4GD/E
4GA4/B4
MN3E
MN4E
W4GA/B2
W4GB4
MN3S0
MN4S0
4SA/B0
4KA/B
4KA/B (master)
4F
4F (master)
PV5G
GMF
PV5
GMF
PV5S-0
3Q
MV3QR
3MA/B0
3PA/B
P/M/B
NP/NAP
NVP
4G*0EJ
4F*0EX
4F*0E
HMV
HSV
2QV
3QV
SKH
Silencer
TotAirSys (Total Air)
TotAirSys (Gamma)
Ending

M4SB0 Series

Reduced wiring manifold; sub-plate piping

Dimensions

M4SB0*0-M5-D4T30

● D sub-connector upward facing: (Port P M5)

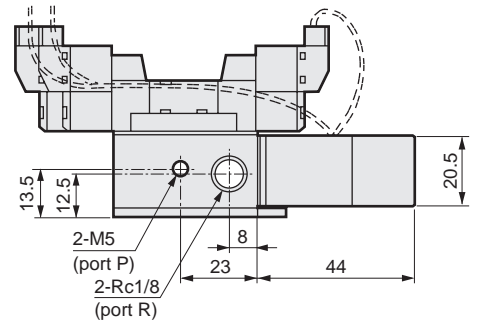
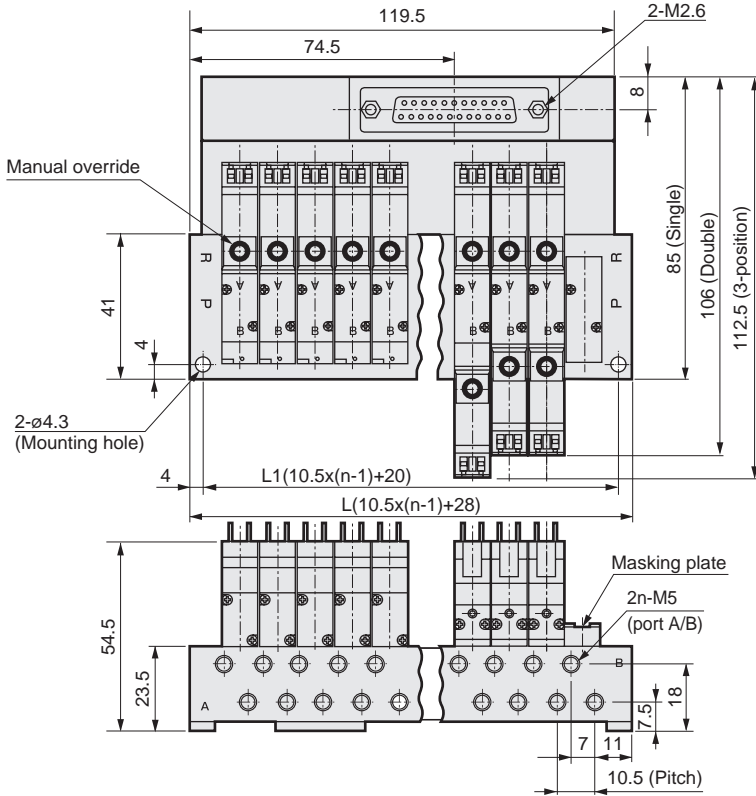

M4SB0*0-M5-C4T31

● D sub-connector lateral facing: (Port P M5)

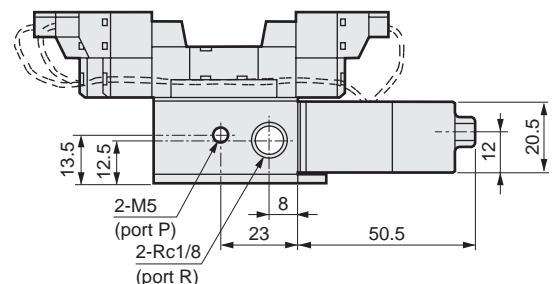
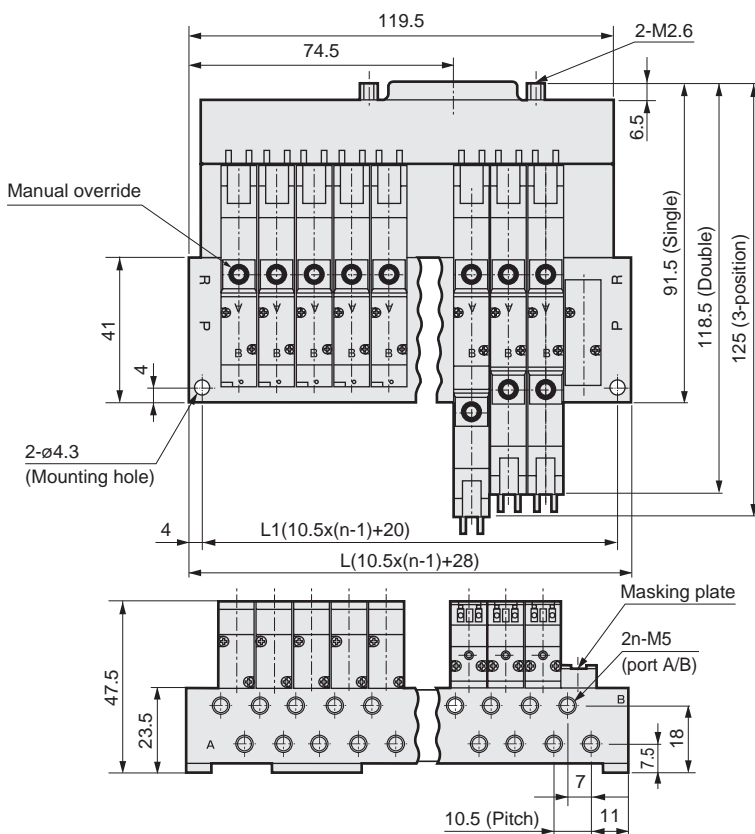

Station No.	4	5	6	7	8	9	10	11	12	13	14	15	16	17	18	19	20
L1	51.5	62	72.5	83	93.5	104	114.5	125	135.5	146	156.5	167	177.5	188	198.5	209	219.5
L	59.5	70	80.5	91	101.5	112	122.5	133	143.5	154	164.5	175	185.5	196	206.5	217	227.5

- 4GA/B
- M4GA/B
- MN4GA/B
- 4GA/B (master)
- 4GB With sensor
- 4GD/E
- M4GD/E
- MN4GD/E
- 4GA4/B4
- MN3E
- MN4E
- W4GA/B2
- W4GB4
- MN3S0
- MN4S0
- 4SA/B0**
- 4KA/B
- 4KA/B (master)
- 4F
- 4F (master)
- PV5G
- GMF
- PV5
- GMF
- PV5S-0
- 3Q
- MV3QR
- 3MA/B0
- 3PA/B
- P/M/B
- NP/NAP
- NVP
- 4G*0EJ
- 4F*0EX
- 4F*0E
- HMV
- HSV
- 2QV
- 3QV
- SKH
- Silencer
- TotAirSys (Total Air)
- TotAirSys (Gamma)
- Ending

Dimensions

● Port A/B M5, port P 1/8:
(PM5)

● $\varnothing 4$ push-in fitting: (GS4/PGS4)

● $\varnothing 4/\varnothing 6$ barbed fitting:
(T4/T6/PT4/PT6)

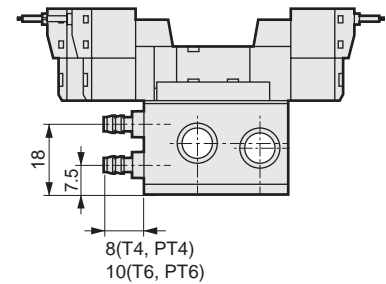
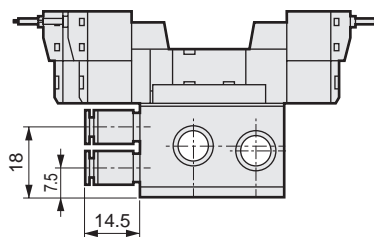
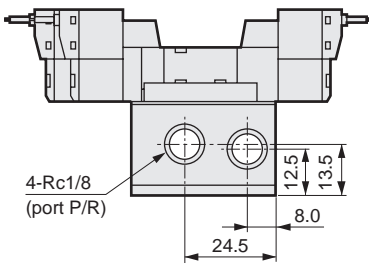
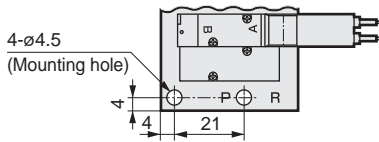

M4SB0*0-M5-C4T50

● Flat cable connector: (Port P M5)

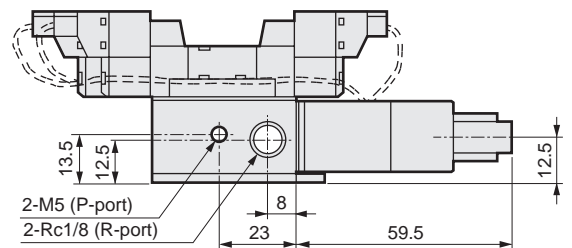
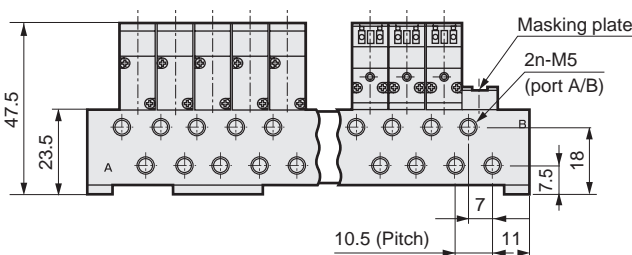
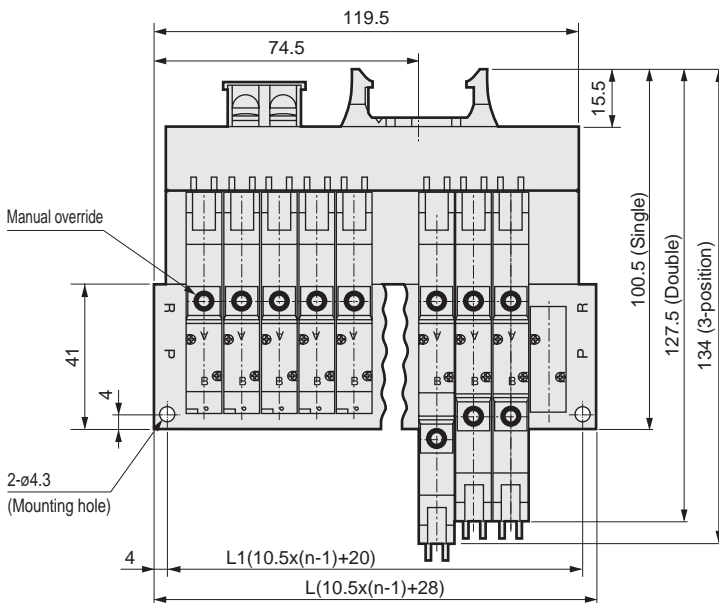

Station No.	4	5	6	7	8	9	10	11	12	13	14	15	16
L1	51.5	62	72.5	83	93.5	104	114.5	125	135.5	146	156.5	167	177.5
L	59.5	70	80.5	91	101.5	112	122.5	133	143.5	154	164.5	175	185.5

4GA/B
M4GA/B
MN4GA/B
4GA/B (master)
4GB With sensor
4GD/E
M4GD/E
MN4GD/E
4GA4/B4
MN3E MN4E
W4GA/B2
W4GB4
MN3S0 MN4S0
4SA/B0
4KA/B
4KA/B (master)
4F
4F (master)
PV5G GMF
PV5 GMF
PV5S-0
3Q
MV3QR
3MA/B0
3PA/B
P/M/B
NP/NAP NVP
4G*0EJ
4F*0EX
4F*0E
HMV HSV
2QV 3QV
SKH
Silencer
TotAirSys (Total Air)
TotAirSys (Gamma)
Ending