

Hydraulic Motors M3 - M4 Series

Denison Vane Technology, fixed displacement



ENGINEERING YOUR SUCCESS.

Contents

General Information	Introduction and product key features	3
	Description of the M3 - M4 motors	4
Main Technical Data	Installation and connection	5
	Displacement and specific torque.....	6
	Maximum speed and pressure	6 - 7
	Hydraulic fluids and seals.....	8
	Motor installation	8
Ordering Code	M3B - M3B1 motors.....	8
	M4C - M4C1 motors.....	10
	M4D - M4D1 motors.....	12
	M4E motors.....	14
Operating characteristics	M3B - M3B1 motors.....	8
	M4C - M4C1 motors.....	10
	M4D - M4D1 motors.....	12
	M4E motors.....	14
Dimension Drawings	M3B - M3B1 motors.....	9
	M4C - M4C1 motors.....	11
	M4D - M4D1 motors.....	13
	M4E motors.....	15
Technical Data	M3B - M3B1 performance charts	16
	M4C - M4C1 performance charts.....	17 - 19
	M4D - M4D1 performance charts.....	20 - 21
	M4E performance charts.....	22
	Minimum replenishment pressure during deceleration	23
Circuit Design	Motor selection example	24
	Hydraulic fluids, types of seals, motor installation	25
	Shaft and coupling data.....	26
	Start-up instructions	26
	Warning.....	27

Introduction**The M3 - M4 hydraulic motors****Introduction**

This wide range of hydraulic vane motors allows selection of a model to suit any particular application. They are used industrially where there is a need to provide a relatively high torque from a power source of small dimensions. The low moment of inertia of the rotating group admits high acceleration and deceleration resulting in rapid response to system control signals.

This catalogue describes the existing sizes of M3B and M4 hydraulic vane motors in their various standard construction types. Equipment manufacturers who may request additional options or have specific requests, are welcome to contact us for a tailored solution study.



Licensing for this image came with permission from the Parker Hannifin Media Manager collection.

Key features**Reliable performance**

The M3 and M4 motors have been designed especially for severe duty applications which require long lasting medium pressure, high speed and reversing capabilities even with low fluid lubricity. Their performances remain stable over time.

Long lifetime

The fully pressure balanced concept increase the motor lifetime over its full speed range. Double lip vanes reduce the sensitivity to fluid pollution.

The bearing capabilities are totally dedicated to the external loads on the shaft ends, whatever the operating pressures are.

Low noise

Simply silent! The Denison Vane Technology allows a very low noise level, whatever the speed.

Low torque ripple

Thanks to their 10 vanes, advanced cam ring profile, two torque cycles per revolution and low internal dead volumes, the M3 and M4 motors exhibit a very low torque ripple, even at low speeds.

Versatility and compactness

With several displacements for the same installation size, the M3 and M4 motors are very powerful and compact.

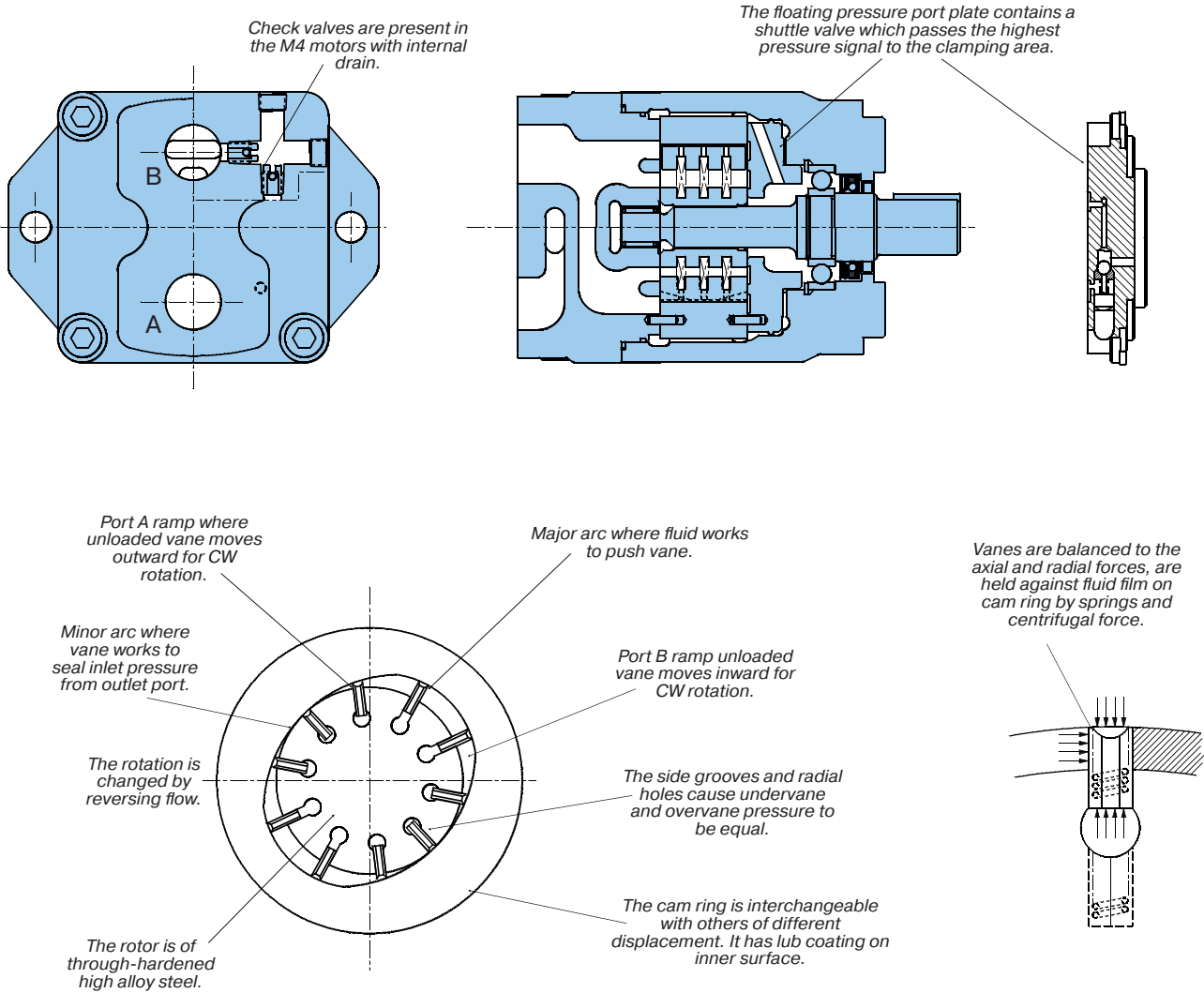

Operation

- The motor shaft is driven by the rotor. The vanes, closely fitted into the rotor slots move radially to seal against the cam ring. The ring has two major and two minor radial sections joined by transitional sections called ramps. These contours and the pressures exposed to them are balanced diametrically.
- Light springs urge the vanes radially against the cam contour assuring a seal at zero speed so the motor can develop starting torque. The springs are assisted by centrifugal force at higher speeds. Radial grooves and holes through the vanes equalize radial hydraulic forces on the vanes at all times. Fluid enters and leaves the motor cartridge through opening in the side plates at the ramps. Each motor port connects to two diametrically opposed ramps. Pressurized fluid entering at Port A torques the rotor clockwise. The rotor transports it to the ramp openings which connect to Port B from which it returns to the low pressure side of the system. Pressure at Port B torques the rotor counter-clockwise.
- The rotor is axially separated from the sideplate surface by the fluid film. The front pressure port plate is clamped against the cam ring by the pressure, maintains optimum clearance as dimensions change with temperature and pressure. A 3-way shuttle valve in the port plate causes clamping pressure in Port A or B, whichever is the highest.
- Materials are chosen for long life efficiency. The vanes, rotor and cam ring are made out of hardened high alloy steels. The cast iron port plate and the end cap are chemically etched to offer a fine crystalline surface allowing a better lubrication at start-up.

Installation and connection

	Mounting flange	Weight without connector and bracket - kg	Moment of inertia $\text{kgm}^2 \times 10^{-4}$	Option for inlet and outlet port
M3B	SAE J744c ISO/3019-1 SAE A	8.0	3.0	SAE threaded SAE 4 bolts J718c ISO/DIS 6162-1 - 3/4" BSPP threaded
M4C	SAE J744c ISO/3019-1 SAE B	15.4	7.9	SAE threaded SAE 4 bolts J718c ISO/DIS 6162-1 - 1"
M4D	SAE J744c ISO/3019-1 SAE C	27.0	21.8	SAE threaded SAE 4 bolts J718c ISO/DIS 6162-1 - 1.1/4"
M4E	SAE J744c ISO/3019-1 SAE C	45.0	58.5	SAE threaded SAE 4 bolts J718c ISO/DIS 6162-1 - 2"

Drain line option

All these motors may be equipped with internal drain. Then the model numbers will be M3B1, M4C1, M4D1.

- Externally drained motors M3B, M4C, M4D, M4E : These motors may be alternately pressurized at Ports A & B. Whichever port is at low pressure should not be subjected to more than 35 bar.

If it is necessary to exceed these limitations, please contact your Parker representative for application assistance.

- Internally drained motors M3B1, M4C1, M4D1 : These motors may be alternately pressurized at Ports A & B. Whichever port is at low pressure must not be subjected to more than 1,5 bar for M3B, 3,5 bar for M4 (pressure peak 7 bar).

Displacement and specific Torque

Series	Size	Ring size	Theor. Displ. V_i	Theoretical Torque T	Power at 100 rpm	Torque T		Power P	
			cm/rev.	Nm/bar	kW/bar	n = 2000 rpm at Δp 175 bar		n = 2000 rpm at Δp 175 bar	
							Nm	kW	
M3	B	018	18.5	0.304	0.0032	46.6	10.0		
		027	27.8	0.485	0.0050	77.4	16.3		
		036	37.1	0.624	0.0065	102.0	21.1		
M4	C	024	24.4	0.39	0.0040	60.5	12.7		
		027	28.2	0.45	0.0047	70.0	14.7		
		031	34.5	0.55	0.0058	86.8	18.0		
		043	46.5	0.74	0.0078	120.0	25.1		
		055	58.8	0.93	0.0098	149.0	31.2		
		067	71.1	1.13	0.0120	170.0	35.6		
		075	80.1	1.27	0.0130	198.0	41.5		
	D	088	91.1	1.45	0.0150	236.0	49.4		
		102	105.5	1.68	0.0180	264.0	55.3		
		113	116.7	1.86	0.0200	300.0	62.8		
		128	132.4	2.11	0.0220	340.0	71.2		
		138	144.4	2.30	0.0240	372.0	77.9		
	E	153	158.5	2.52	0.0260	398.0	83.4		
		185	191.6	3.05	0.0320	484.0	101.4		
		214	222.0	3.53	0.0370	567.0	118.8		

For further information or if the performance characteristics outlined above do not meet your own particular requirements, please consult your local Parker representative.

To insure maximum motor performance in conjunction with your specific application, consult your local Parker representative if your application requires, minimum speed of less than 100 rpm, indirect drive, overrunning loads, braking or retarding.

Maximum Speed and pressure

Series	Size	Displ.	Max. pressure					Operating pressure range drain	Max. speed for low loaded condition ¹⁾	Max. speed for max. pressure ratings						
			HF-0	HF-6a	HF-1	HF-3	HF-4			HF-0	HF-2	HF-6a, HF6b	HF-1			
			HF-2	HF-6b	HF-5	bar	bar			bar	bar	rpm	rpm	rpm	rpm	rpm
M3	B	018	210						1.5	4000	3000	3600				
		027														
		036														
M4	C	024	230	175	175	140	3.5	4000	2500	3600	2500	3600	2000	2500		
		027														
		031														
		043														
		055													210	
		067														
		075													175	
	D	088	230	140	140	140	3.5	4000	2500	3000	2500	3000	2000	2500		
		102	210													
		113	190													
		128	175													
	E	153	190	140	140	140	3.5	3600	2500	3000	2500	3000	1800	2200		
		185	180													
		214	175													

1) Low loaded condition 35 bar for M3, 80 bar max. for M4 (see page 8).
2) Intermittent speed - Do not exceed 6 seconds per minute of operation.

- HF-0, HF-2 = Antiwear petroleum base.
- HF-1 = Non antiwear petroleum base.
- HF-3 = Water in oil emulsions.
- HF-4 = Water glycols.
- HF-5 = Synthetic fluids.
- HF-6a = Saturated HEES Bio fluids.
- HF-6b = Partially saturated HEES Bio fluids.

Internal drain : All these motors may be equipped with internal drain. Then the model will be M3B1, M4C1, M4D1.

Maximum ratings M3B

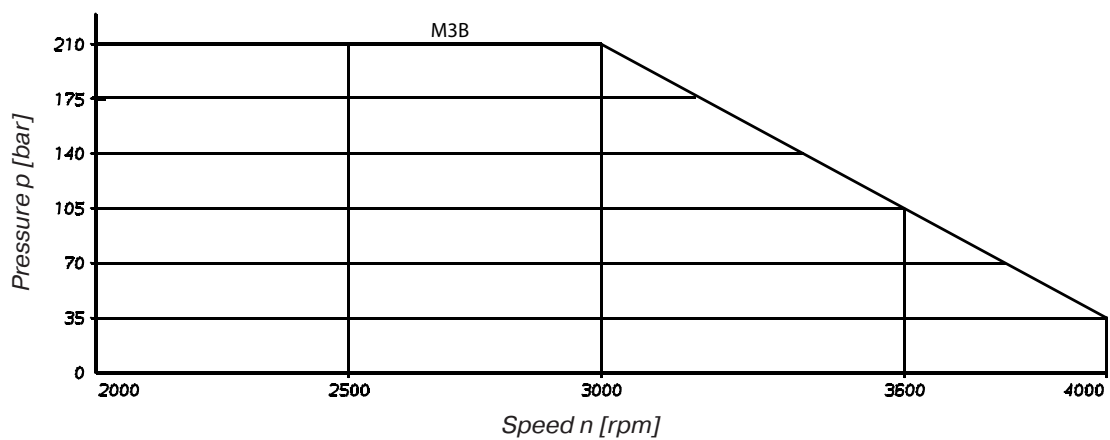

- Running condition limits - Typical curves at 26 cSt @ 45°.
- For higher specifications or for operating speed under < 100 rpm, please consult Parker.

Maximum ratings M4C

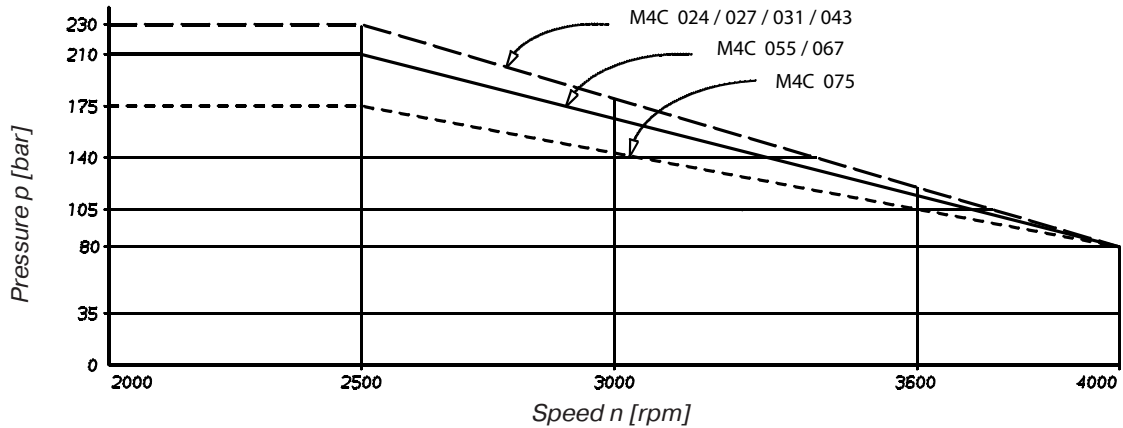

Maximum ratings M4D

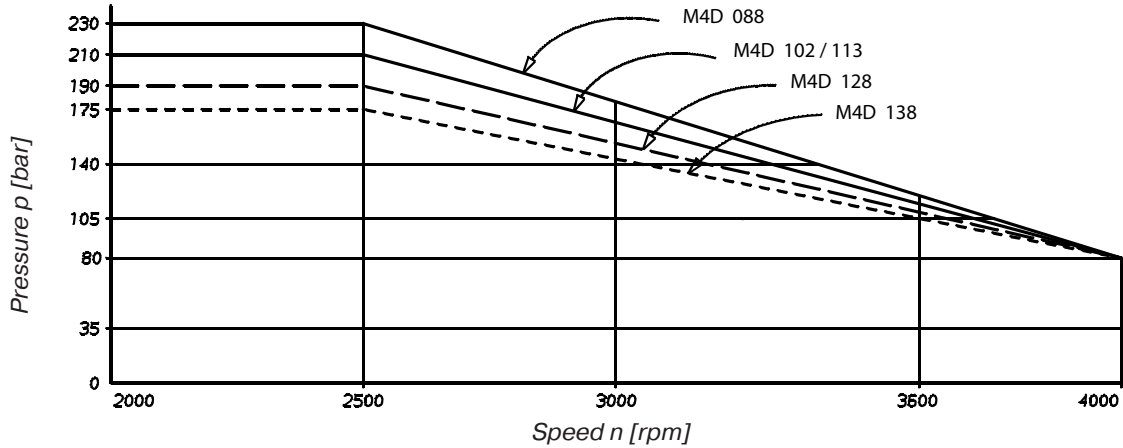

Maximum ratings M4E

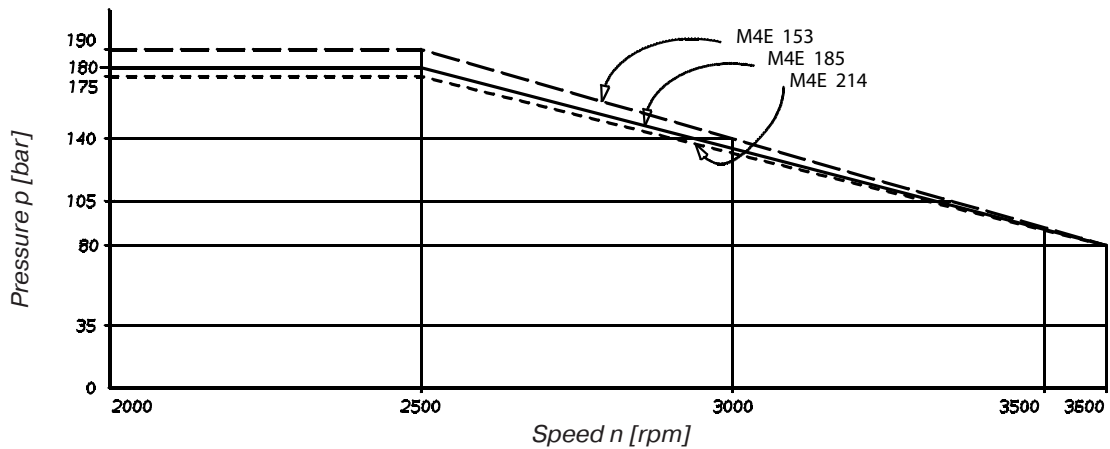

- Running condition limits - Typical curves at 26 cSt @ 45°.
- For higher specifications or for operating speed under < 100 rpm, please consult Parker.

Model No. M3B1 M3B - 036 - 1 N 00 - B 1 02 -

M3B - Series external drain
M3B1 - Series internal drain

Torque
018 = 0.304 Nm/bar
027 = 0.485 Nm/bar
036 = 0.624 Nm/bar

Type of shaft
1 = keyed (non SAE)
3 = splined (SAE A)
4 = splined (SAE B)

Direction of rotation (shaft end view)
N = bi-directional
CW rotation => A = inlet B = outlet
CCW rotation => B = inlet A = outlet

Modifications
Ports
02 = BSPB threaded port
BSPB drain

Seal class
1 = S1 - BUNA N
5 = S5 - VITON®

Design letter
Porting combination
00 = standard

Operating Characteristics - Typical [24 cSt]

Model	V _i Volumetric displacement cm ³ /rev.	Input flow at n = 2000 rpm		Torque T at n = 2000 rpm	Power output at n = 2000 rpm
		Theoretical	at 175 bar Δ p	at 175 bar Δ p	at 175 bar Δ p
		l/min	l/min	Nm	kW
M3B 018	18.5	37.0	49.0	46.6	10.0
M3B 027	27.8	55.6	67.6	77.4	16.3
M3B 036	37.1	74.2	86.2	102.0	21.1

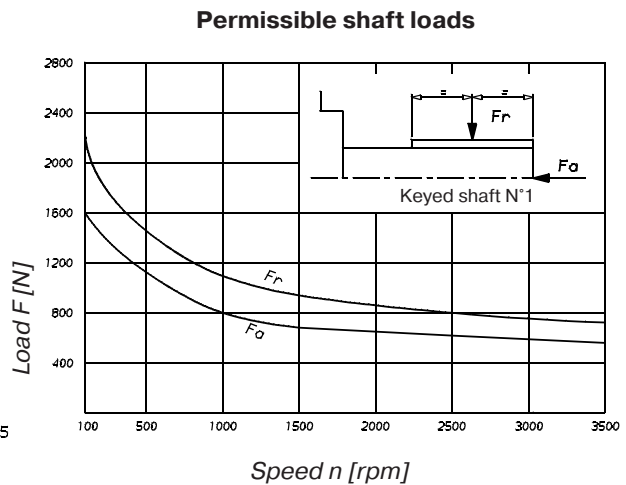
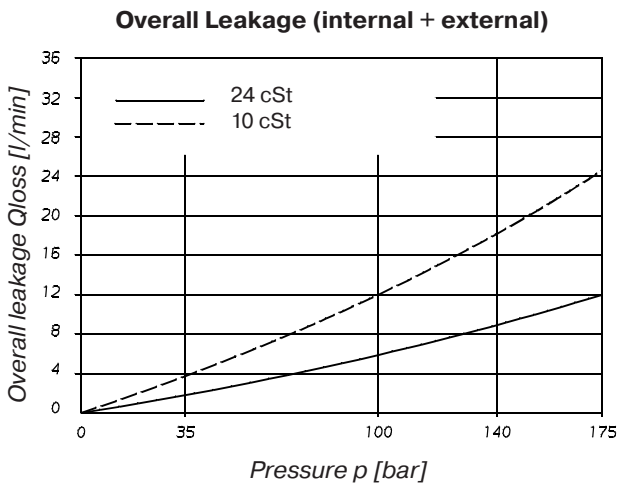

Do not apply Fr and Fa loads simultaneously

M3B - M3B1 motor

Weight : 8.0 kg

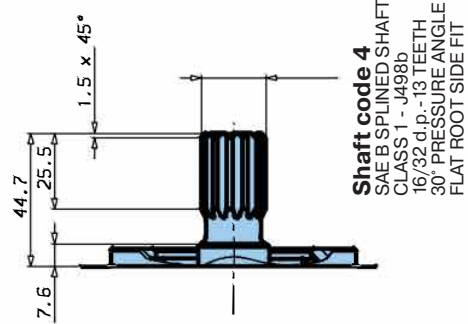
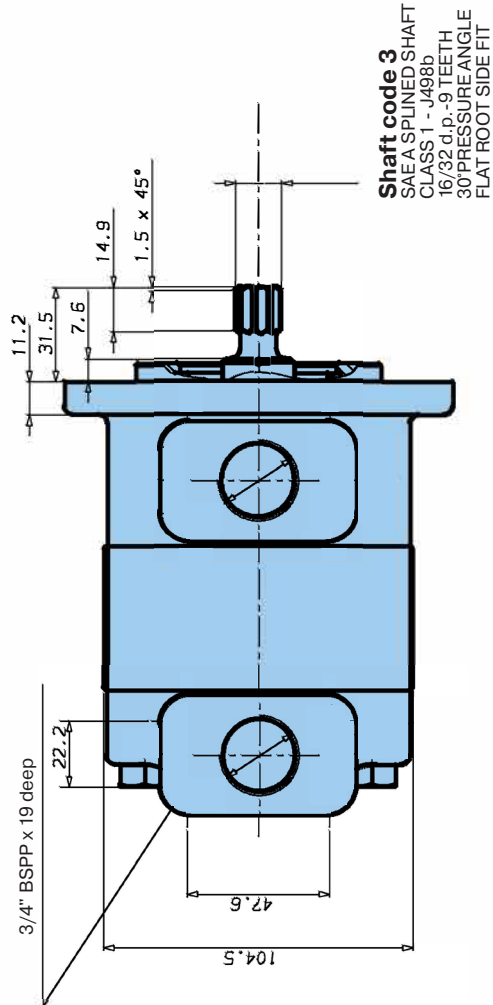
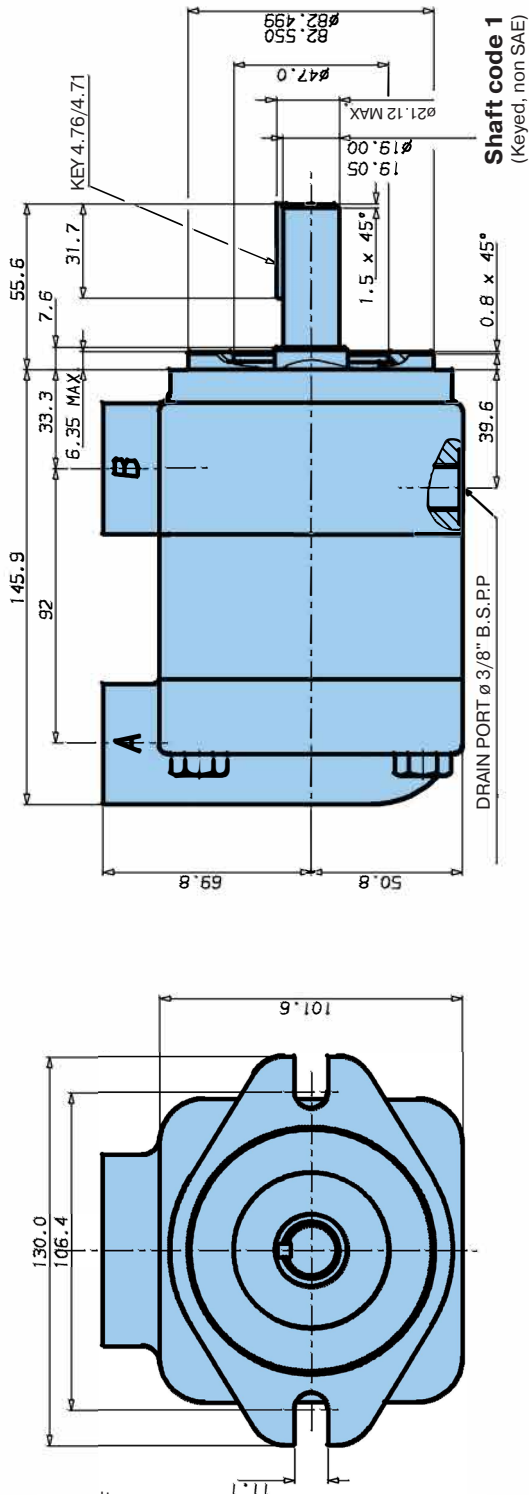

PORT

M4C - M4C1 motor

Weight : 15.4 kg

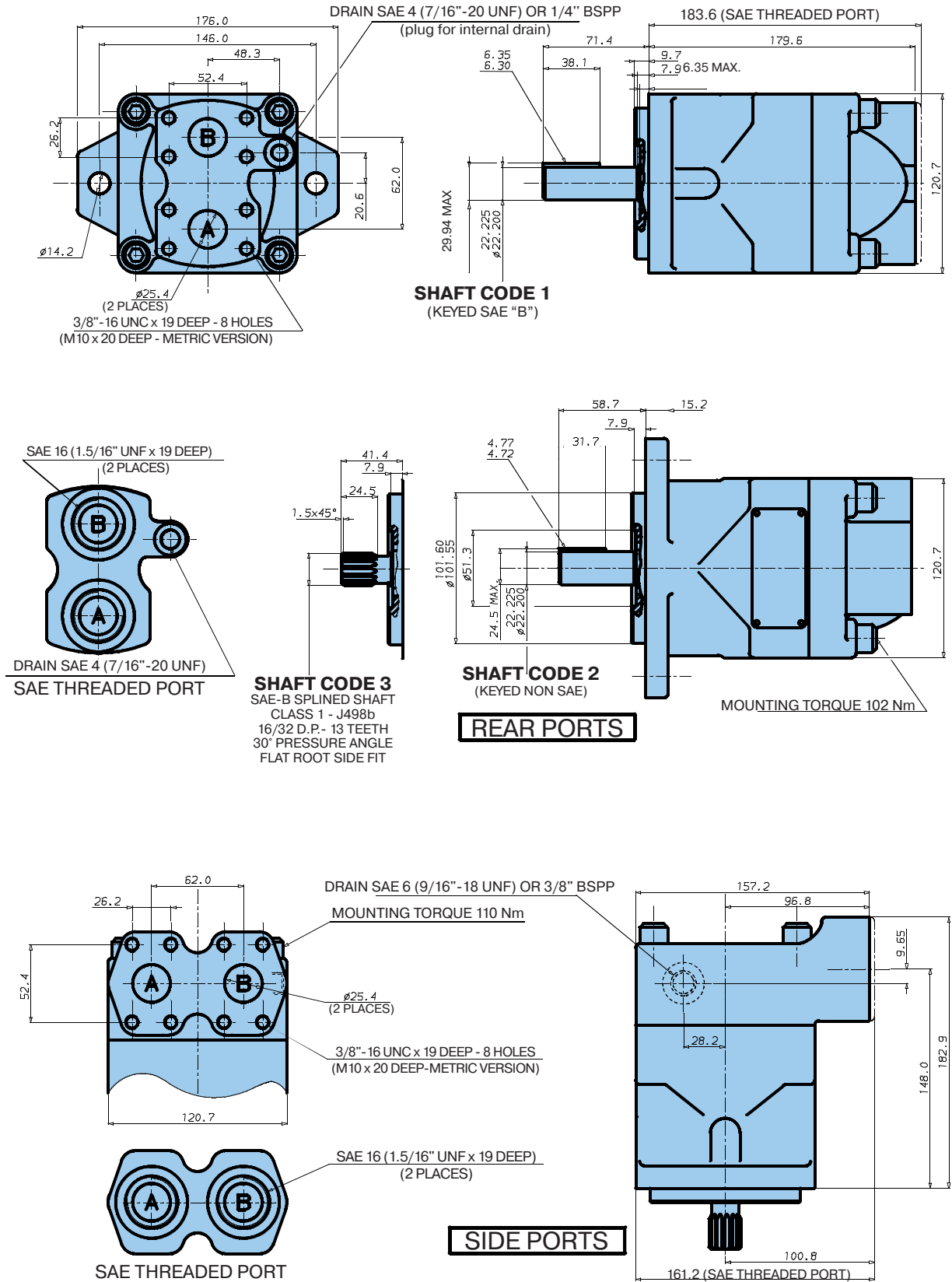

Ordering Code

Model No. M4D1
M4D - 138 - 1 N 00 - B 1 02 ..

M4D - Series external drain

M4D1 Series internal drain

Torque

- 088 = 1.45 Nm/bar
- 102 = 1.68 Nm/bar
- 113 = 1.86 Nm/bar
- 128 = 2.11 Nm/bar
- 138 = 2.30 Nm/bar

Type of shaft

- 1 = keyed (SAE C)
- 3 = splined (SAE C)

Direction of rotation (shaft end view)

- N = bi-directional
- CW rotation => A = inlet B = outlet
- CCW rotation => B = inlet A = outlet

Modifications

Ports

- 01 (M4D only) = SAE threaded port SAE drain
- 02 (M4D & M4D1) = 4 bolt SAE flange with UNC threads SAE drain

Seal class

- 1 = S1 - BUNA N
- 5 = S5 - VITON®

Design letter

Porting combination

- 00 = standard

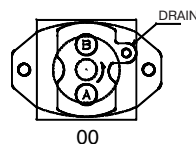

M4D1 : Drain port is plugged.

Operating Characteristics - Typical [24 cSt]

Model	V _i Volumetric displacement cm ³ /rev.	Input flow at n = 2000 rpm		Torque T at n = 2000 rpm	Power output at n = 2000 rpm
		Theoretical l/min	at 175 bar Δp l/min	at 175 bar Δp Nm	at 175 bar Δp kW
M4D 088	91.0	182.0	206.0	236.0	49.4
M4D 102	105.5	211.0	241.0	264.0	55.3
M4D 113	116.7	233.0	257.0	300.0	62.8
M4D 128	132.4	265.0	289.0	340.0	71.2
M4D 138	144.4	289.0	313.0	372.0	77.9

Overall Leakage (internal + external)

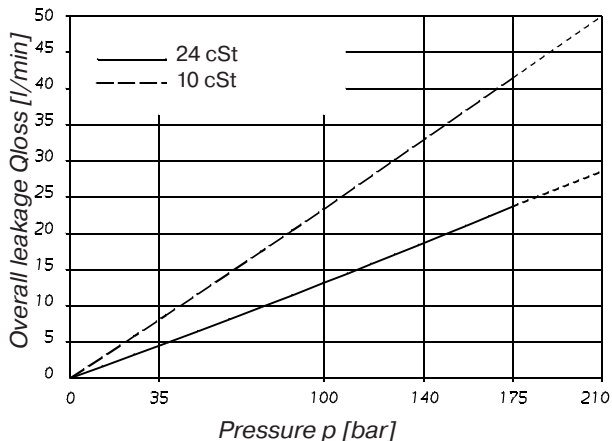

Permissible shaft loads

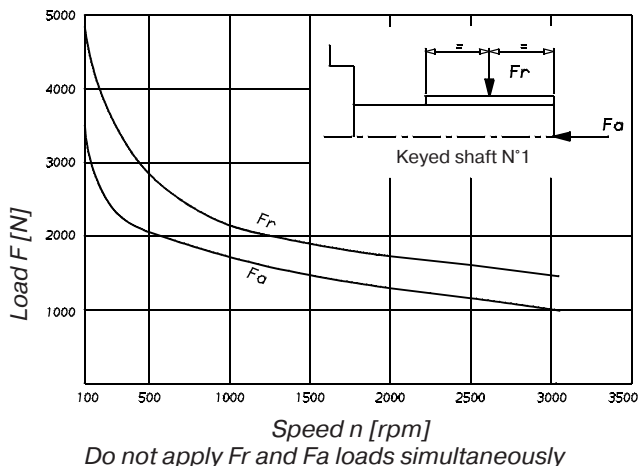

M4D - M4D1 motor

Weight : 27.0 kg

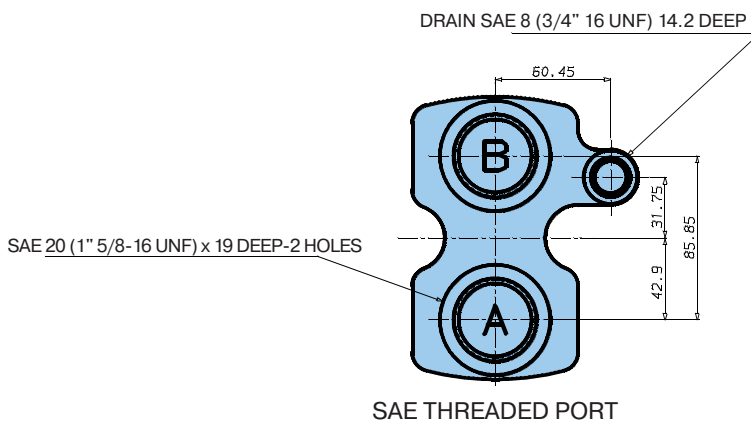
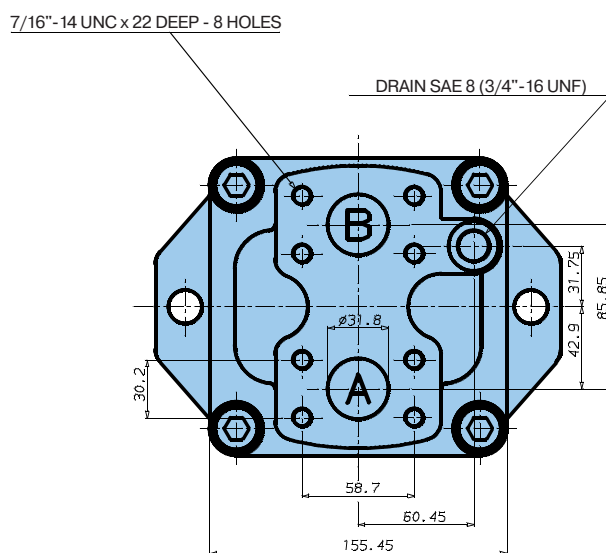
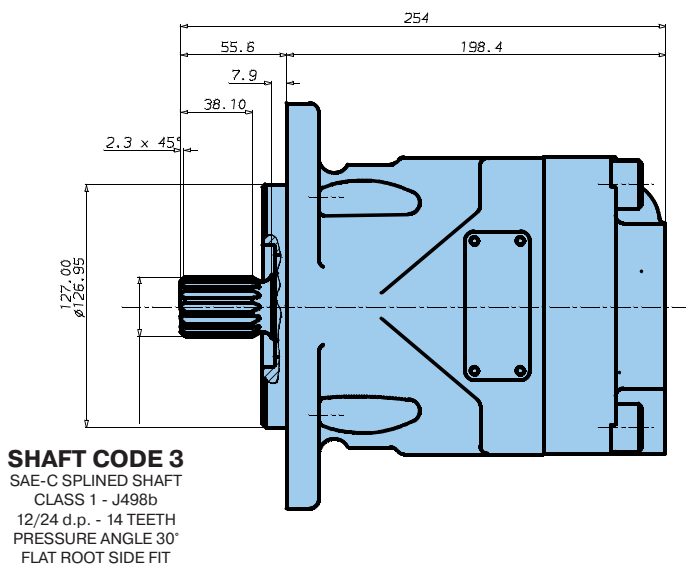
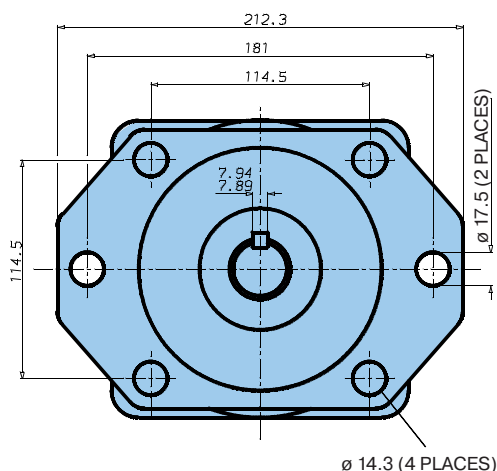
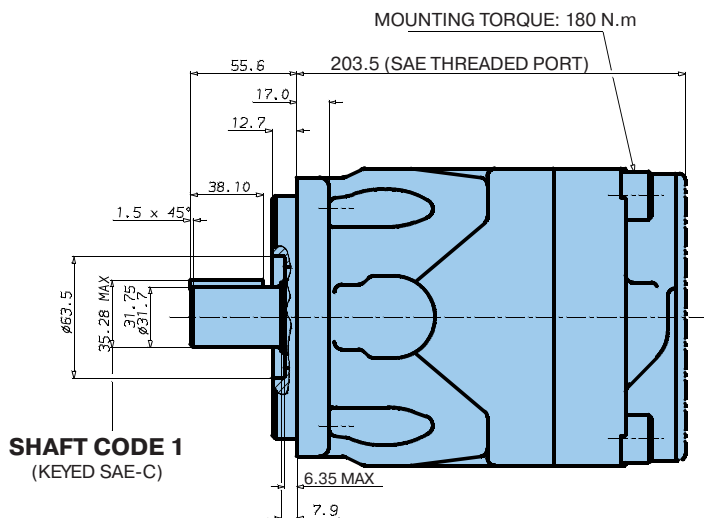

Ordering Code

Model No. **M4E - 214 - 1 N 00 - B 5 02 ..**

M4E - Series external drain

Torque

- 153 = 2,52 Nm/bar
- 185 = 3,05 Nm/bar
- 214 = 3,53 Nm/bar

Type of shaft

- 1 = keyed (SAE C)
- 3 = splined (SAE C)

Direction of rotation (shaft end view)

N = bi-directional

- CW rotation => A = inlet B = outlet
- CCW rotation => B = inlet A = outlet

Modifications

Ports

02 = 4 bolt SAE flange with UNC threads
 SAE drain

Seal class

5 = S5 - VITON®

Design letter

Porting combination

00 = standard

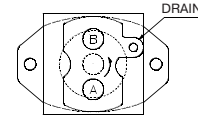

00

Operating Characteristics - Typical [24 cSt]

Model	V _i Volumetric displacement cm ³ /rev.	Input flow at n = 2000 rpm		Torque T at n = 2000 rpm	Power output at n = 2000 rpm
		Theoretical	at 175 bar Δp	at 175 bar Δp	at 175 bar Δp
		l/min	l/min	Nm	kW
M4E 153	158.5	317.0	343.0	398.0	83.4
M4E 185	191.6	383.0	409.0	484.0	101.4
M4E 214	222.0	444.0	470.0	567.0	188.8

Overall Leakage (internal + external)

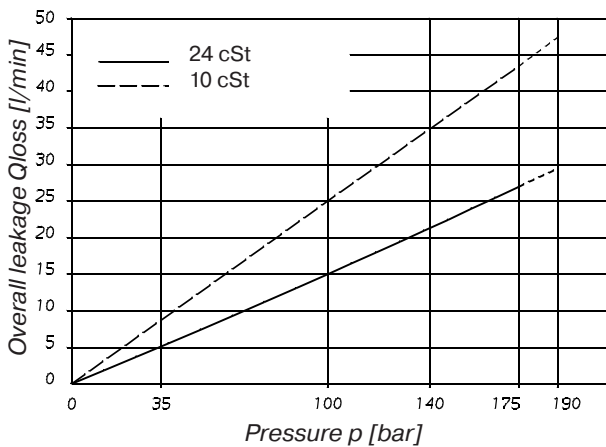

Permissible shaft loads

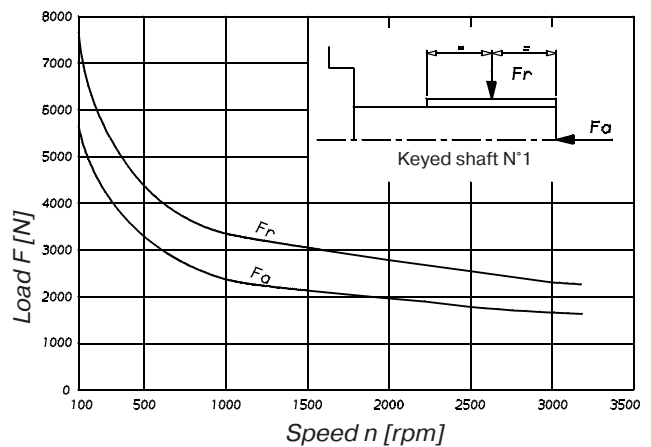

Do not apply Fr and Fa loads simultaneously

M4E motor

Weight : 45.0 kg

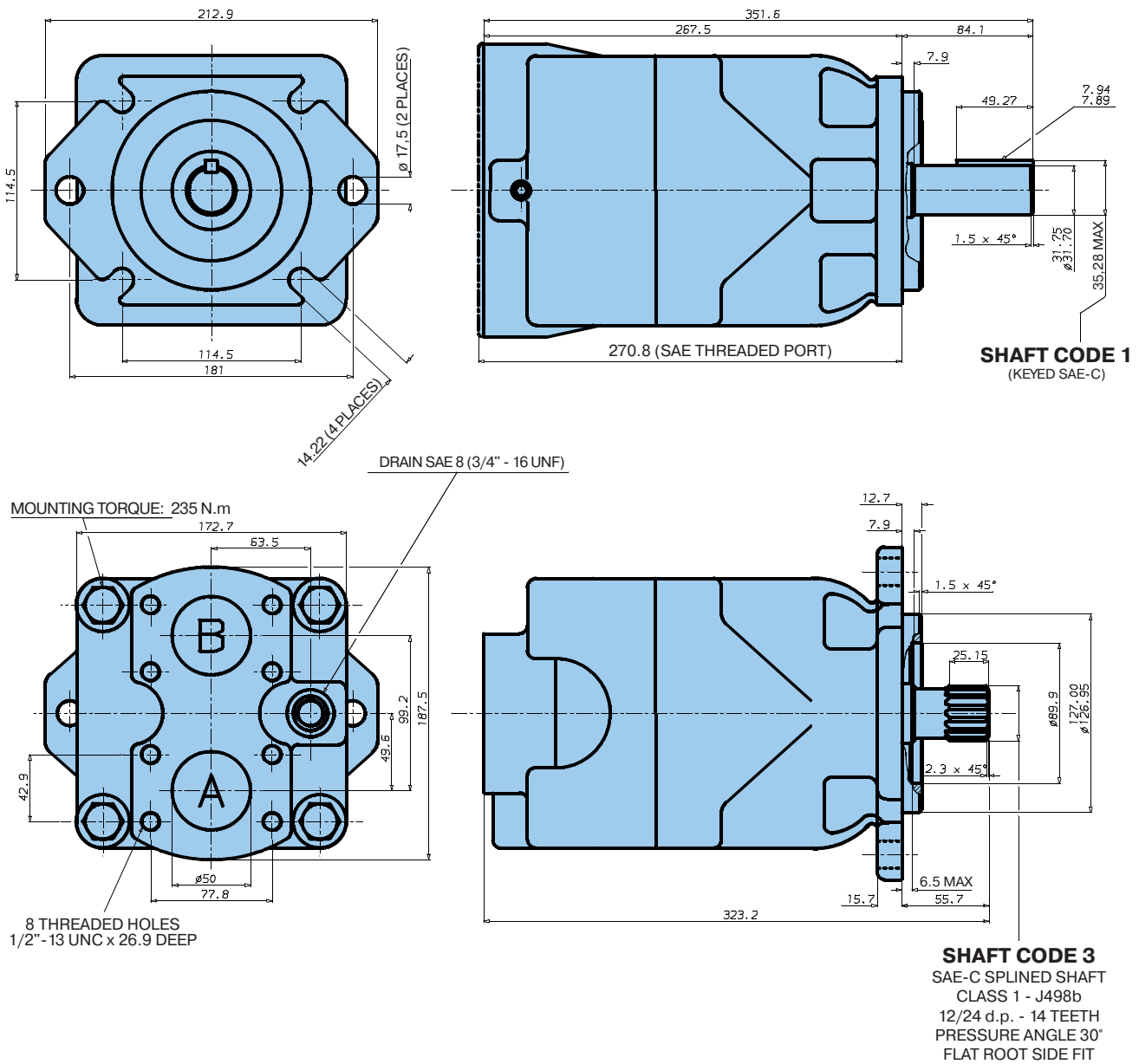

Performance charts

M3B 018

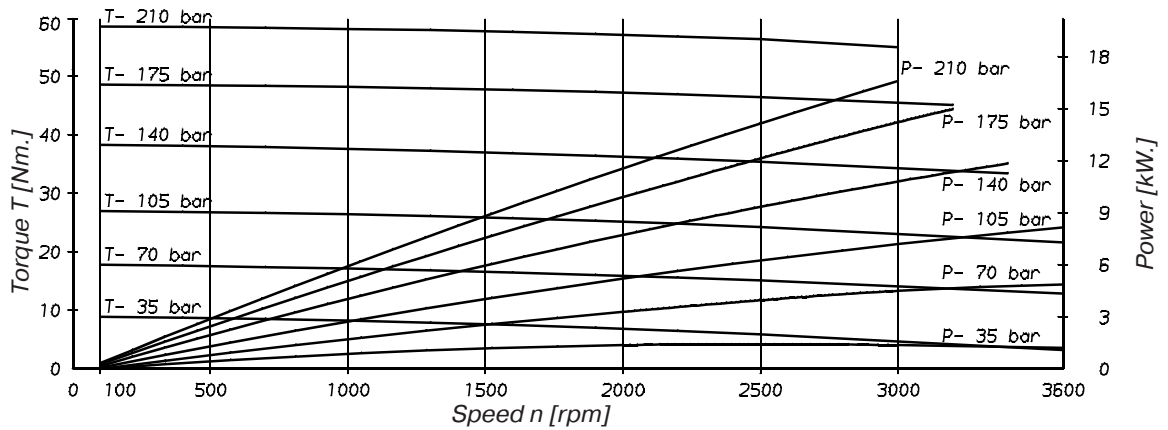

M3B 027

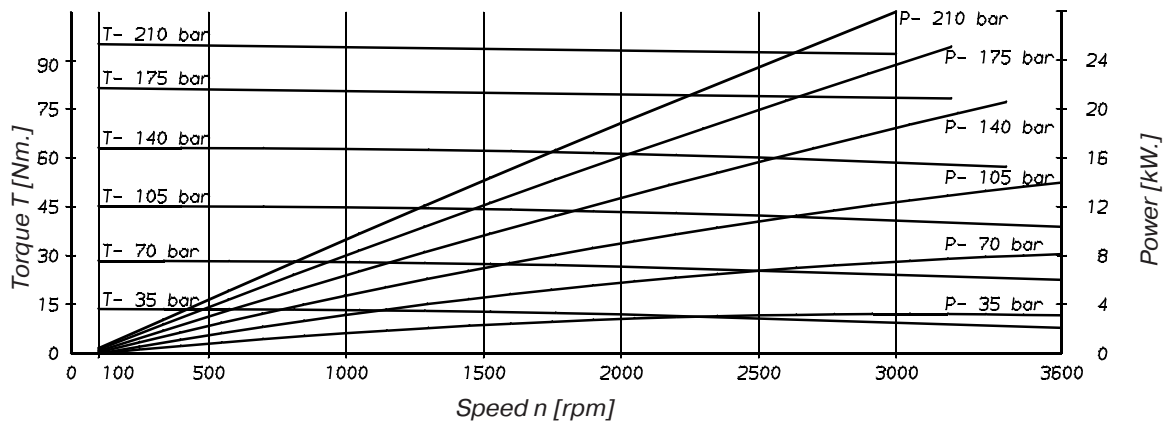

M3B 036

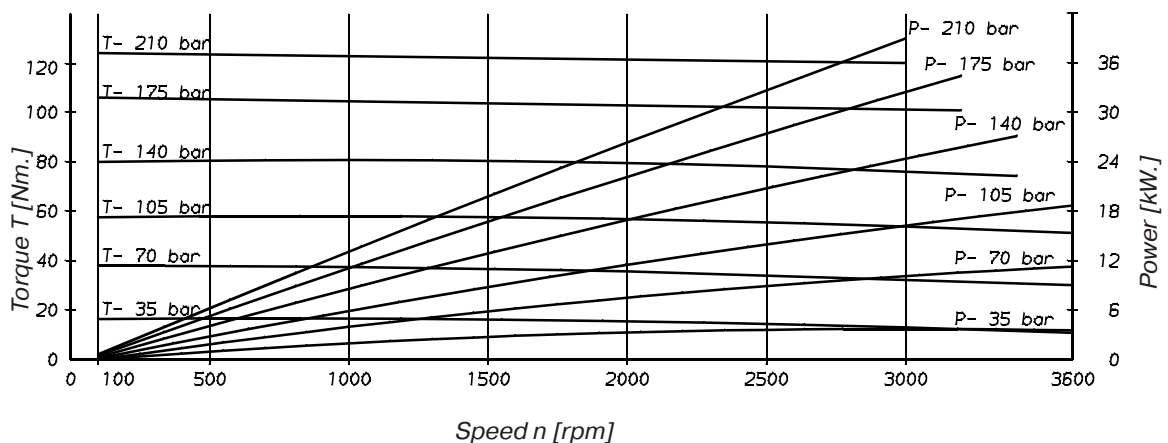

- Running condition limits - Typical curves at 26 cSt @ 45°.
- For higher specifications or for operating speed under < 100 rpm, please consult Parker.

Performance charts

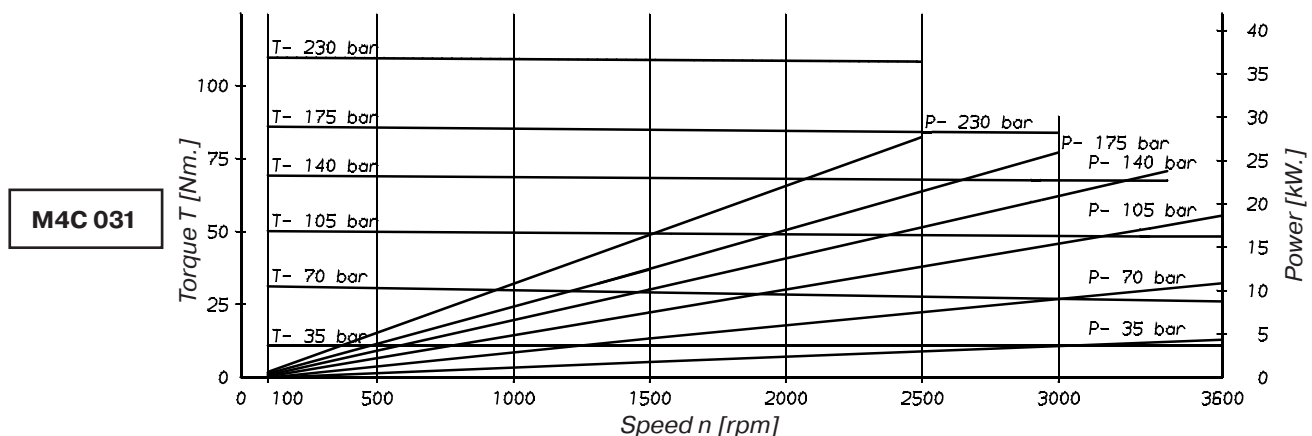
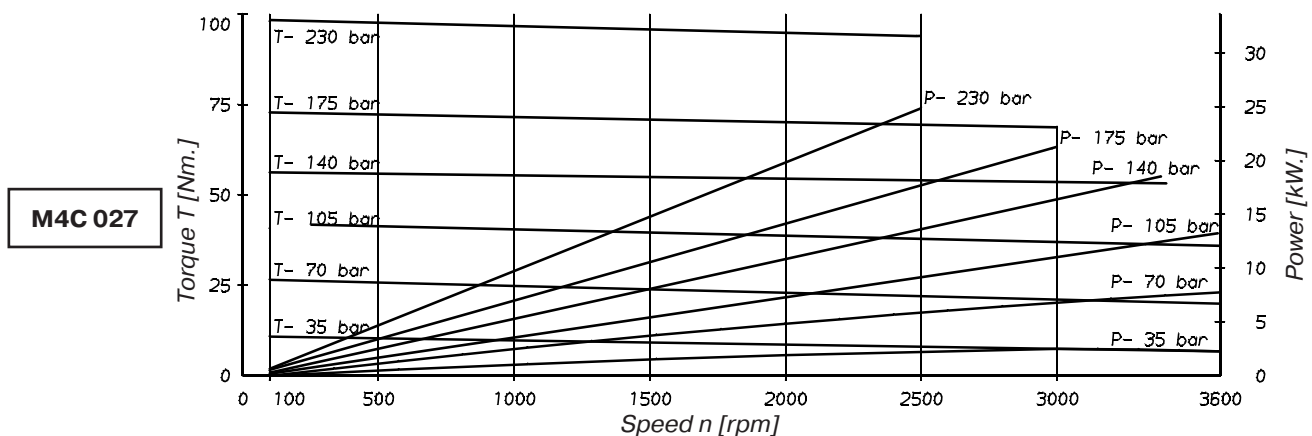
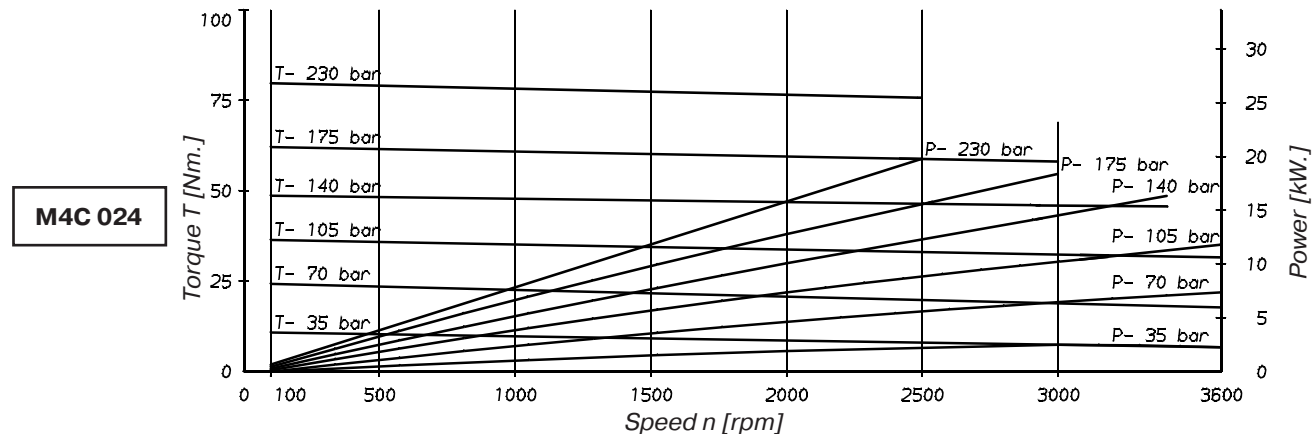

- Running condition limits - Typical curves at 26 cSt @ 45°.
- For higher specifications or for operating speed under < 100 rpm, please consult Parker.

Performance charts

M4C 043

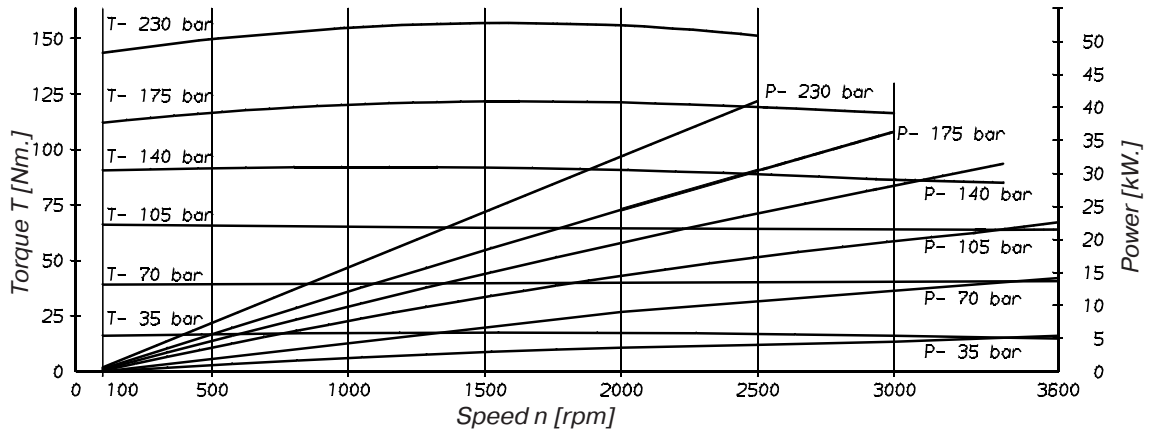

M4C 055

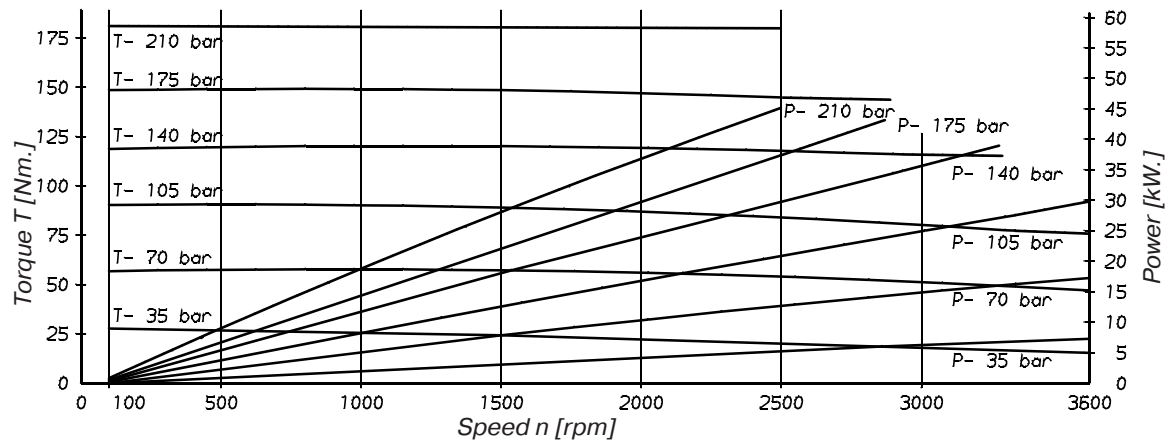

M4C 067

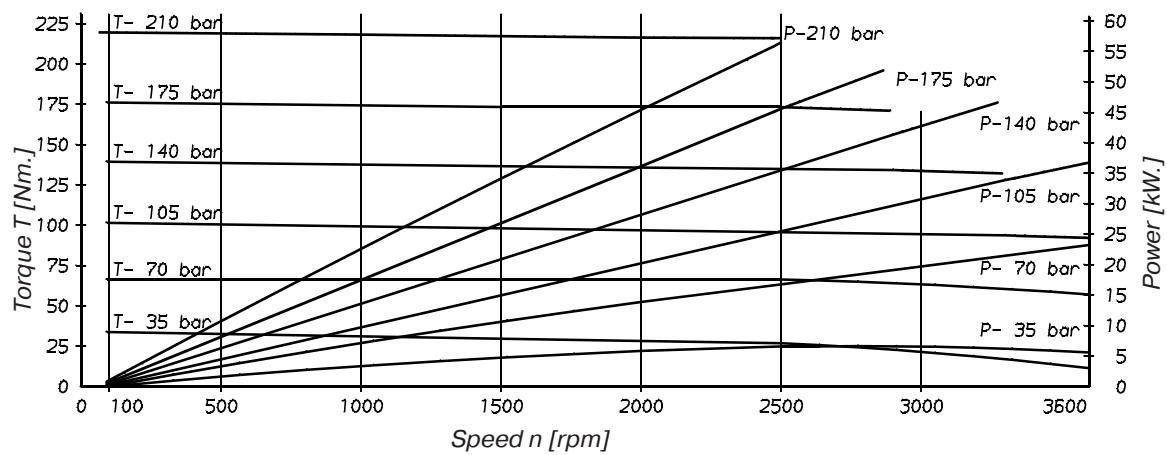

- Running condition limits - Typical curves at 26 cSt @ 45°.
- For higher specifications or for operating speed under < 100 rpm, please consult Parker.

Performance charts

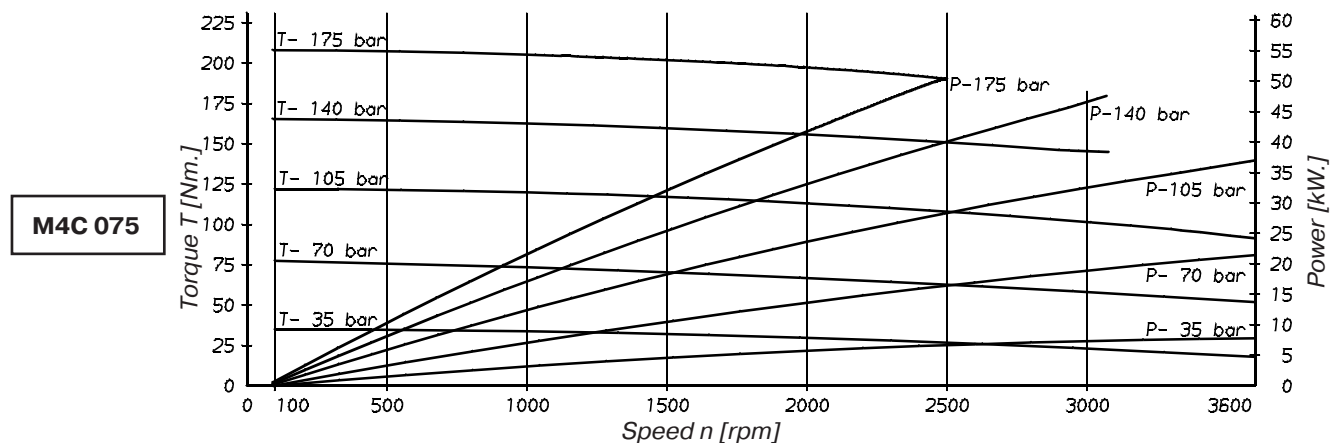

- Running condition limits - Typical curves at 26 cSt @ 45°.
- For higher specifications or for operating speed under < 100 rpm, please consult Parker.

Performance charts

M4D 088

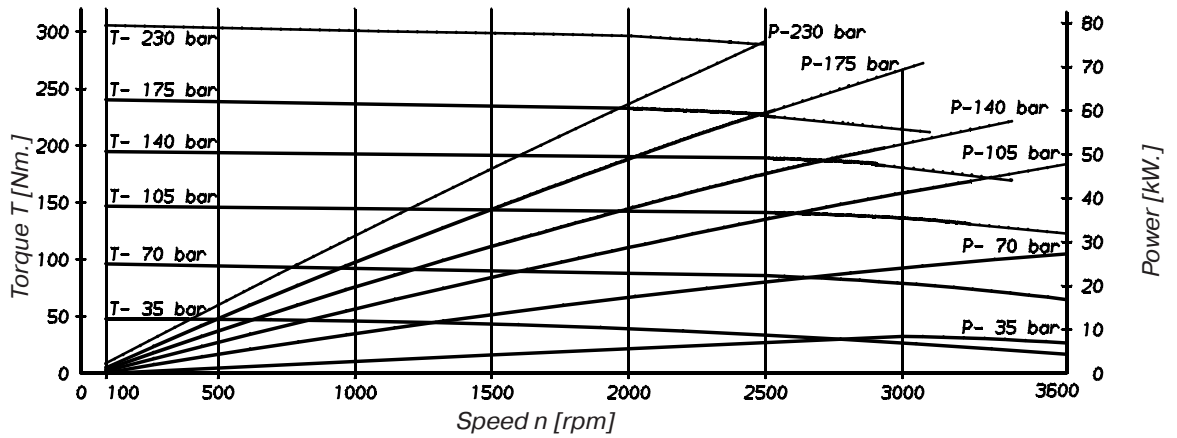

M4D 102

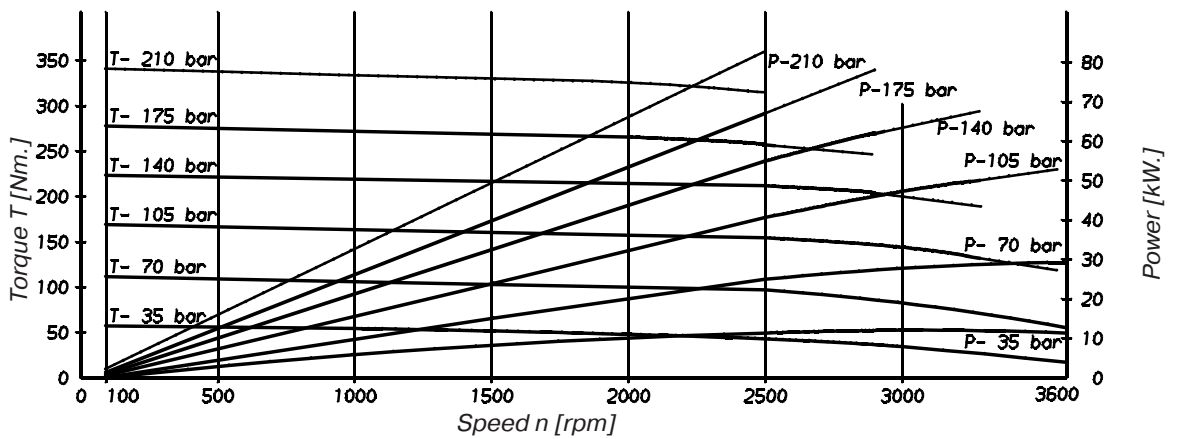

M4D 113

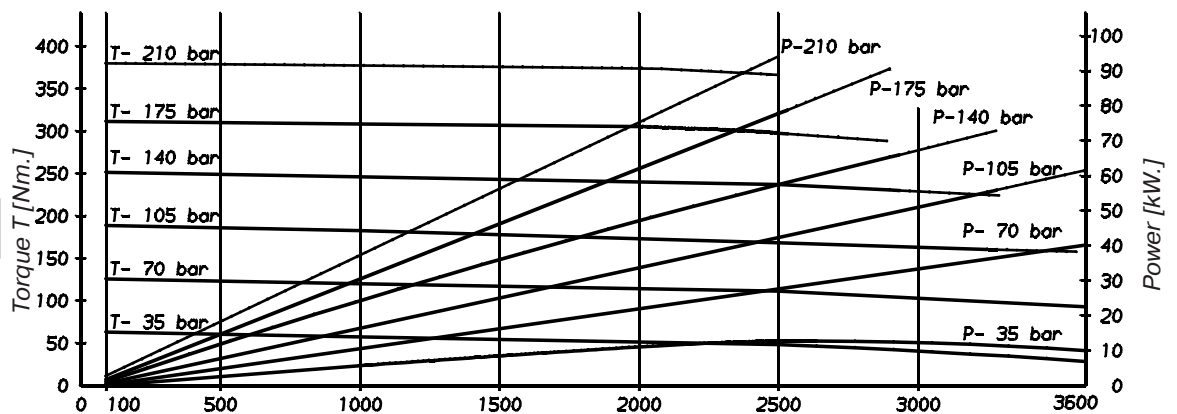

- Running condition limits - Typical curves at 26 cSt @ 45°.
- For higher specifications or for operating speed under < 100 rpm, please consult Parker.

Speed n [rpm]

Performance charts

M4D 128

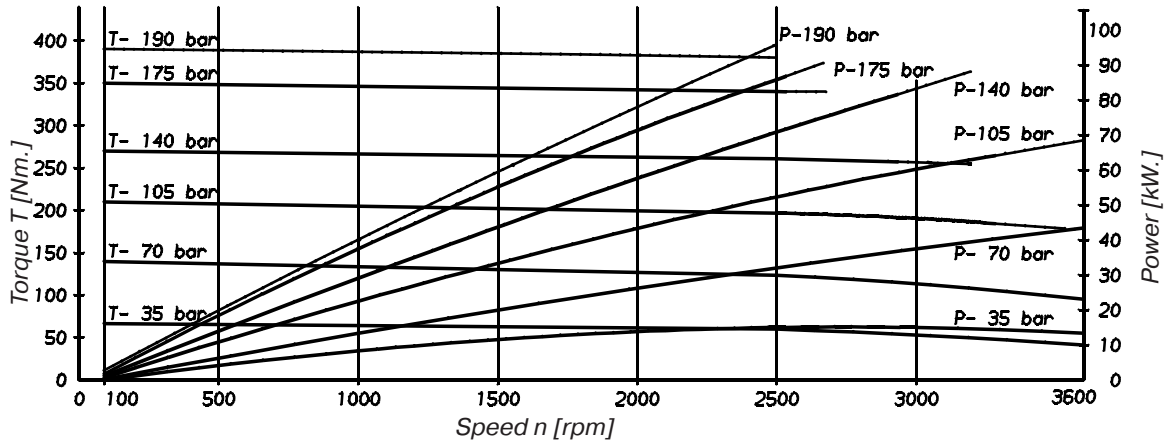

M4D 138

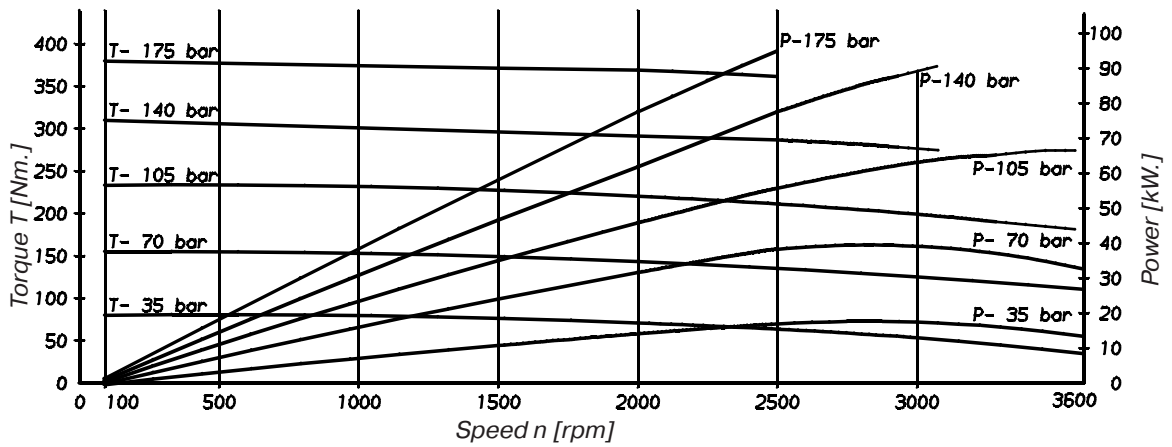

- Running condition limits - Typical curves at 26 cSt @ 45°.
- For higher specifications or for operating speed under < 100 rpm, please consult Parker.

Performance charts

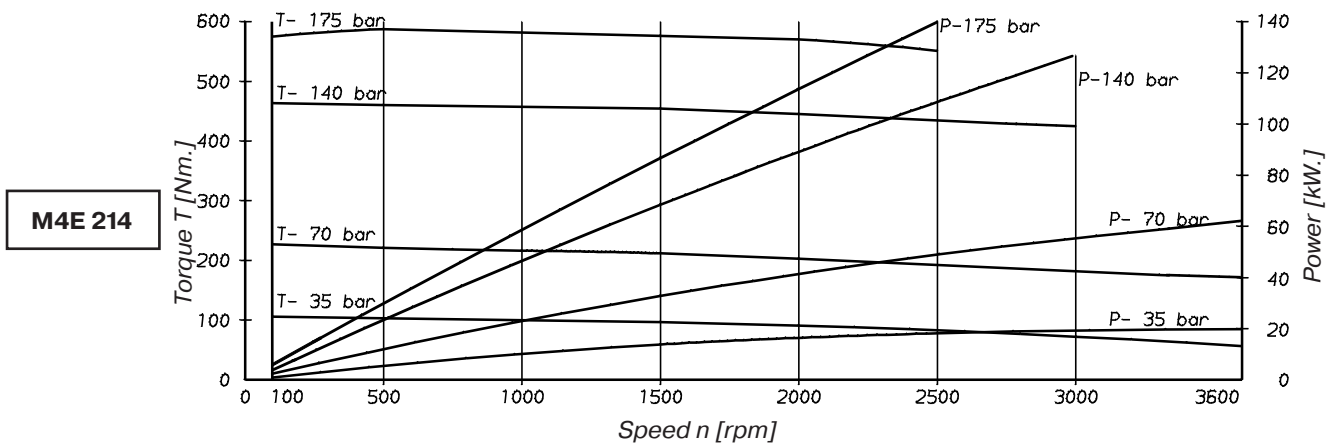
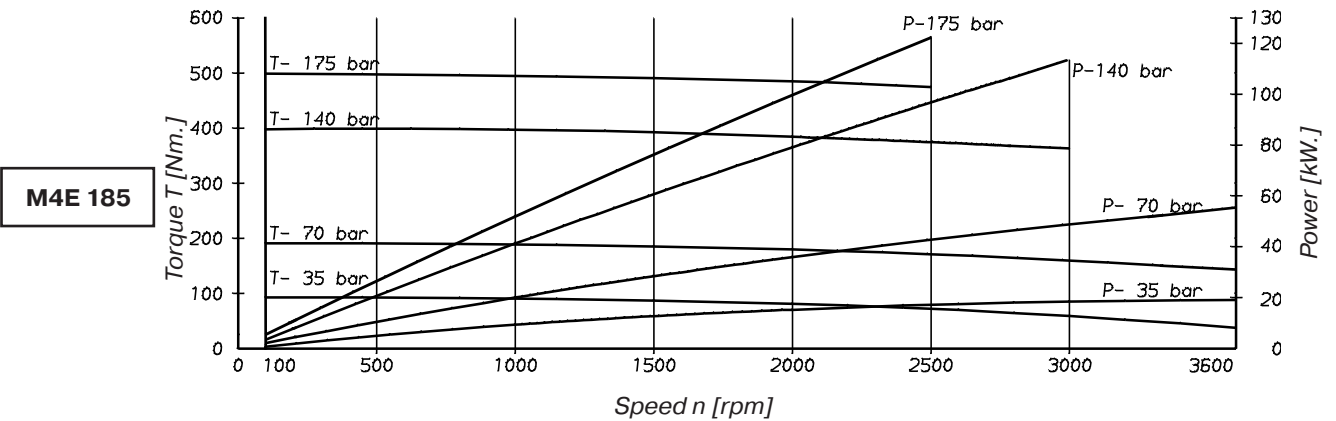
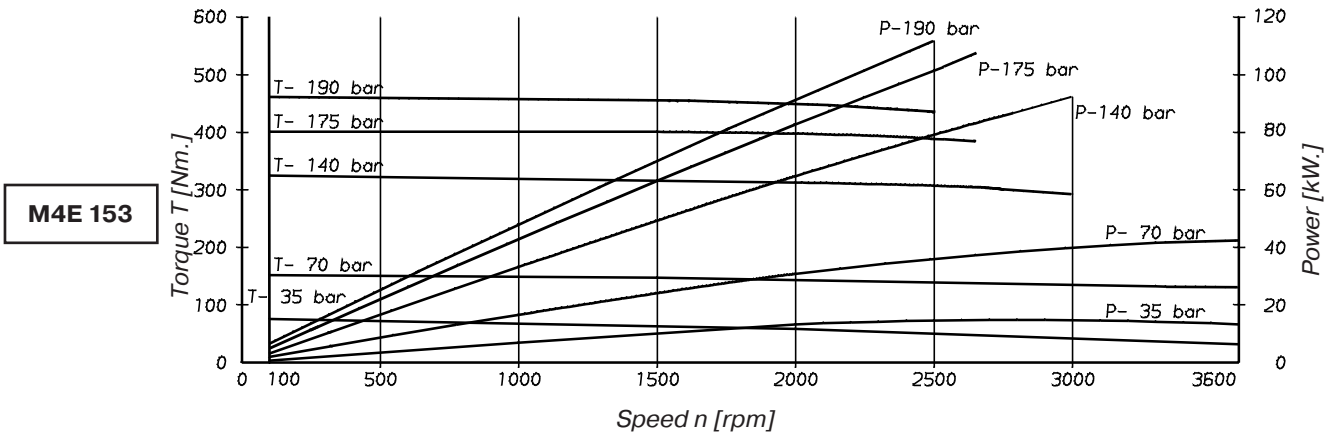

- Running condition limits - Typical curves at 26 cSt @ 45°.
- For higher specifications or for operating speed under < 100 rpm, please consult Parker.

Performance charts

Minimum replenishment pressure during deceleration

The hydraulic circuit should be designed in a way that when switching off the hydraulic motor, it remains supplied with fluid, without risk of cavitation (anti-cavitation valve may be needed).

The inlet port of the fluid motor must be supplied with replenishment pressure as listed below to prevent cavitation during dynamic braking. These pressures should be multiplied by a coefficient of 1,5 for M4 motors used with fire resistant fluids (HF-3, HF-4, HF-5).

Minimum replenishment pressure (bar)					
Series	Speed [rpm] - Oil viscosity = 32 cSt				
	500	1000	2000	3000	3600
M3B	0.6	1.0	1.9	3.5	5.8
M4C	0.7	1.4	3.1	5.5	9.3
M4D	0.7	1.4	3.1	5.5	9.3
M4E	1.4	2.8	5.2	11.0	

Reverse cycles for fan drives

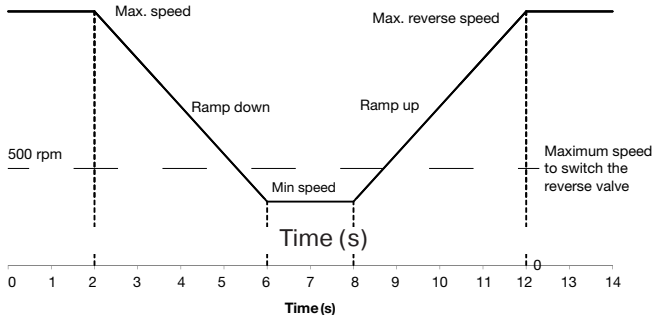

The motor must be decelerated from its (max.) rotation speed to less than 500 rpm in no less than 4 seconds time before energizing the solenoid of the reverse valve.

In the same way the motor must be ramped up to its (max.) reverse rotation speed in no less than 4 seconds time.

There should be no signs of cavitation during the reverse cycle (abnormal noise or lack of replenishment pressure).

Connection of several motors in the same circuit

For application requiring several motors to be driven simultaneously, we recommend to connect these in parallel circuits.

The use of several motors connected in series is not recommended. Depending on the different inertia of the loads, the displacements and torque requirements, the motors may be subjected to pressure instability and noise. Also hydraulic pressure valves will not admit high levels of back pressure, restricting this use to motors without pressure valves. Please consult Parker.

Circuit Design

Motor selection example

Motor performances required

Torque _____ T[Nm.] 140
Speed _____ n[rpm] 1500

Pump available data

Flow _____ Q [l/min] 115
Δ Pressure _____ Δ p [bar] 175

1. Check if available power is greater than required power (0.85 estimated overall efficiency).

$$0.85 \times \frac{Q \times p}{600} \geq \frac{T \times \pi \times n}{30 \times 1000}$$

$$28.5 > 22 \text{ kW}$$

$$0,85 \times \frac{115 \times 175}{600} \geq \frac{140 \times \pi \times 1500}{30 \times 1000}$$

2. Two ways of calculation : Calculate V_i from T required torque, or from Q available flow.

2a. Calculate V_i from T required torque

$$V_i = \frac{20 \pi \times T}{p} = \frac{20 \pi \times 140}{175} = 50.26 \text{ cm}^3/\text{rev.}$$

2b. Calculate V_i from Q available flow

$$V_i = \frac{1000 \times 175}{1500} = 76.7 \text{ cm}^3/\text{rev.}$$

3a. Choose motor from V_i immediately greater
M4C 055 $V_i = 58.8 \text{ cm}^3/\text{rev.}$ (see page 10)

3b. Choose motor from V_i immediately smaller
M4C 067 $V_i = 71.1 \text{ cm}^3/\text{rev.}$ (see page 10)

4a. Check real motor pressure for T = 140 Nm. at around 1500 rpm
M4C 055 T = 140 N.m n = 1500 rpm
p = 160 bar (see M4C 055 curve on page 19)

4b. Check motor pressure with T = 140 Nm. at 1500 rpm
M4C 067 T = 140 Nm. n = 1500 rpm
p = 140 bar (see M4C 067 curve on page 19)

5a. Flow loss at this pressure : 16 l/min
(see page 10)

Real flow used by the motor :
 $Q_{\text{eff.}} = 115 - 16 = 99 \text{ l/min}$

5b. Flow loss at this pressure : 14 l/min
(see page 10)

Real flow used by the motor :
 $Q_{\text{eff.}} = 115 - 14 = 101 \text{ l/min}$

6a. Real speed of the motor :

$$n_{\text{eff.}} = \frac{Q_{\text{eff.}} \times 1000}{V_i} = \frac{99 \times 1000}{58.8} = 1683 \text{ rpm}$$

6b. Real speed of the motor :

$$n_{\text{eff.}} = \frac{Q_{\text{eff.}} \times 1000}{V_i} = \frac{101 \times 1000}{71.1} = 1420 \text{ rpm}$$

Real performances

$V_i = 58.8 \text{ cm}^3/\text{rev.}$
 $n_{\text{eff.}} = 1683 \text{ rpm}$
 $T = 140 \text{ Nm.}$
 $\Delta p_{\text{eff.}} = 160 \text{ bar}$ } M4C 055

Real performances

$V_i = 71.1 \text{ cm}^3/\text{rev.}$
 $n_{\text{eff.}} = 1420 \text{ rpm}$
 $T = 140 \text{ Nm.}$
 $\Delta p_{\text{eff.}} = 140 \text{ bar}$ } M4C 067

Fluid power formulas

Volumetric efficiency	$\frac{1}{1 + \frac{\text{total leakage} \times 1000}{\text{speed} \times \text{displacement}}}$	Speed [rpm]
Mechanical efficiency	$1 - \frac{\text{torque loss} \times 20 \times p}{\Delta \text{ pressure} \times \text{displacement}}$	Displacement [cm ³ /rev]
Fluid motor speed	$\frac{1000 \times \text{flow rate} \times \text{volumetric eff.}}{\text{displacement}}$	Pressure [bar]
Fluid motor torque	$\frac{\Delta \text{ pressure} \times \text{displacement} \times \text{mech. eff.}}{20 \times p}$	Flow rate [l/min]
Fluid motor power	$\frac{\text{speed} \times \text{displacement} \times \Delta \text{ pressure} \times \text{overall eff.}}{600\,000}$ or $\frac{\text{torque} \times \text{speed} \times 20 \times p}{600\,000}$	Leakage [l/min]
		Torque [Nm]
		Torque loss [Nm]
		Power [kW]

Hydraulic fluids

Recommended fluids

Petroleum base anti-wear, anti-rust and anti-oxidation fluids (covered by Parker Denison HF-0 and HF-2 specifications). Maximum catalogue ratings and performance data are based on operation with these fluids.

Acceptable alternate fluids

The use of fluids other than petroleum base anti-wear R & O fluids requires that the maximum ratings of the motor will be reduced. In some cases, the minimum replenishment pressure must be increased.

HF-1 : non antiwear petroleum base HF-4 : water glycols solutions HF-5 : synthetic fluids HF-6a, HF-6b : HEES Bio fluids

Fluids viscosity

The minimum Viscosity Index is 90. The kinematic viscosity range is as below. Over or under these values, please contact Parker.

Max. (cold start, low speed & pressure) ___ 2000 cSt	Min. (full speed & pressure for HF-1, HF-4 & HF-5 fluids) 18 cSt
Max. (full speed & pressure) _____ 108 cSt	Min. (full speed & pressure for HF-0 & HF-2 fluids) 10 cSt
Optimum (max. lifetime) _____ 30 cSt	

Fluids temperatures

The usual limiting factor of temperature (low or high) comes from the obtained viscosity. The seals are sometimes the limit.

Maximum fluid temperature (also depends on min. viscosity). Minimum fluid temperature (also depends on max. viscosity).

	°C	°F		°C	°F
HF-0, HF-1, HF-2 _____	+ 100	(+ 212)	HF-0, HF-1, HF-2, HF-5, HF-6a, HF-6b _____	- 18	(- 0.4)
HF-4 _____	+ 50	(+ 122)	HF-4 _____	+ 10	(+ 50)
HF-5 _____	+ 70	(+ 158)			
HF-6a, HF-6b _____	+ 80	(+ 176)			

Filtration requirements

The fluid must be cleaned before and during operation to maintain a contamination level of ISO 18/16/13 (NAS 1638 class 7) for motors with proportional pressure valve and ISO 19/17/14 (NAS 1638 class 8) or better for others. Filters must be installed accordingly.

Water contamination in fluid

The maximum acceptable content of water shall be limited to 0,10 % for mineral base fluids, and 0.05 %for synthetic fluids, crankcase oils, and biodegradable fluids. The eventual excess of water must be drained off the circuit.

Types of seals

Seals type 1 (S1) : Use this seal type for applications with mineral oil and fluid temperature less than + 90° C (+ 194° F).

S1 seals temperature range : - 40°C to + 107° C (- 40° F to + 225° F).

Seals type 5 (S5) : Use this seal type with some fire resistant fluids and/or fluid temperature higher than + 90° C (+194° F).

S5 seal temperature range : - 29° C to + 204°C (- 20° F to + 400°F).

Motor installation

The Motor may be installed in any position providing that its drain line is correctly laid and that the loads on the shaft are clearly identified and acceptable. Motors fitted with valves will require some light back pressure.

The externally drained motors must have a drain line connected to their housing drain port. It must be of a sufficient size to prevent back pressure in excess of 3.5 bar (50 PSI), and return directly to the reservoir below the minimum fluid level, as far away as possible from the suction pipe of the pump.

It is preferable to install the housing with its drain port upward to facilitate the purge of the motor. If the motor is mounted vertically with the shaft pointing up, then the drain line must have a bend above the motor to purge it fully and to be sure that the shaft seal is well lubricated.



Shaft and coupling data

- **Keyed shafts** : Parker supplies its keyed shaft M3 - M4 motors with high strength heat-treated keys. Therefore, when installing or replacing these motors, the heat-treated keys must be used in order to ensure maximum life in the application. If the key is replaced, it must be a heat-treated key between 27 and 34 R.C. hardness. The corners of the keys must be chamfered by 0.76 mm to 1.02 mm (0.03 to 0.04) at 45° to clear the radii in the key way.

The alignment of the keyed shafts must be within the tolerances given for the splined shafts here below.

- **Couplings and female splines** : The coupling must be selected to minimize the load on the shaft (weight, misalignment).

The female spline must be made to conform to the Class 1 fit as described in SAE-J498b (1971). This is described as a Flat Root Side Fit.

The mating female spline should be free to float and find its own center. If both members are rigidly supported, they must be aligned within 0,15 TIR (0.006" TIR) or less to reduce fretting. The angular alignment of two splines axes must be less than ± 0.05 per 25.4 radius (± 0.002 " per 1" radius).

The coupling must be hardened to a hardness between 29 and 45 HRC.

The coupling spline must be lubricated with a lithium molydisulfide grease, disulfide of molybdenum or a similar lubricant.

Start-up instructions

All Parker hydraulic vane motors are individually factory tested to provide the best quality & reliability. They are to be used within the operation limits indicated in our documentation. Only qualified personnel who is competent and familiar with the installation and operation of hydraulic drives and has hydraulic circuits and hydraulic equipment knowledge is allowed to put the equipment into operation. Make sure to have all necessary documentation available and always conform yourself to the valid regulations (safety, electrical, environment...).

Pre-start checks

- Before the initial installation of the motor, please remove the protective covers or plugs from the connection ports and pour some clean and suitable hydraulic fluid in all ports.
- Before the initial starting of the motor, the following checks should be made :
 - a. Check the requested rotation way of the driven device and make sure that the hydraulic motor shaft will rotate accordingly.
 - b. Check entry, outlet and drain lines to be sure all connections are tight and properly connected.
 - c. Check the cleanliness of the piping, the hydraulic fluid type, its cleanliness and level. Make sure it can reach the motor entry port.
 - d. Check the correct fixture of the hydraulic motor mounting flange and of its driven device. Check their correct coupling.
 - e. For hydraulic motors with built-in solenoid valves, check the electrical wiring and the connections.

First start and air removing

- The pressure relief valve of the circuit should be backed off to its minimum setting value to keep the hydraulic motor unloaded when first started. Circuit priming and air bleed off have to be performed before resetting the pressure relief valve.
- Start the hydraulic motor rotation in a jogging manner until a prime is picked up, and increase its speed from 500 to 1000 rpm. Check that there is no leakage or air suction neither at the ports (inlet, outlet, drain), nor at the shaft end.
- It is important to bleed the air off the circuit, and off the hydraulic motor itself. Purge the air off, preferably using air bleed off valves or pressure test points. Let the hydraulic motor rotate several minutes unloaded.
- Hydraulic motors equipped with a proportional pressure relief valve have to purge the air off the pressure valve in the following way: energize and de-energize the coil 5 times from 0 Amp to max current. Check that the proportional pressure relief valve is properly air bled off by running the hydraulic motor at full speed. It should rotate without vibrations or pulses.

Notes

- In case of very cold temperature, the hydraulic motor should be kept at low pressure and low speed until the fluid warms up, before running it at high pressure or speed.
- If the motor does not work properly or pressure cannot be obtained within seconds, it should be shut down and conditions corrected. Refer to the machine/vehicle manufacturer instructions and motor catalogue.

 **WARNING – USER RESPONSIBILITY**

FAILURE OR IMPROPER SELECTION OR IMPROPER USE OF THE PRODUCTS DESCRIBED HEREIN OR RELATED ITEMS CAN CAUSE DEATH, PERSONAL INJURY AND PROPERTY DAMAGE.

This document and other information from Parker-Hannifin Corporation, its subsidiaries and authorized distributors provide product or system options for further investigation by users having technical expertise.

The user, through its own analysis and testing, is solely responsible for making the final selection of the system and components and assuring that all performance, endurance, maintenance, safety and warning requirements of the application are met. The user must analyze all aspects of the application, follow applicable industry standards, and follow the information concerning the product in the current product catalogue and in any other materials provided from Parker or its subsidiaries or authorized distributors.

To the extent that Parker or its subsidiaries or authorized distributors provide component or system options based upon data or specifications provided by the user, the user is responsible for determining that such data and specifications are suitable and sufficient for all applications and reasonably foreseeable uses of the components or systems.

Offer of Sale

Please contact your Parker representation for a detailed "Offer of Sale".

www.parker.com



European Headquarters
La Tuilière 6, 1163 Etoy,
Switzerland
Tel: +41 21 821 85 00

Your authorized Distributor