

DEUBLIN

1005/1101/1116 Series Rotary Unions for Multi-Media-Application

- Single passage for clamping, unclamping, lubricating, cooling and sensing
- Special design closed seals for multi-media-applications and dry run cycles
- All-purpose design; one model for various applications
- Full-flow design has no obstructions to trap swarf or debris
- Rotor-mounted design for easy installation
- Labyrinth system and large vents to protect ball bearings
- Anodised aluminium housing resists corrosion



Operating Data

Filtration	ISO 4406:2017 Class 17/15/12, max. 60 micron	
Max. Speed**	10.000 min ⁻¹	10,000 rpm
Max. Pressure		
Hydraulic	70 bar	1,015 psi
Coolant	70 bar	1,015 psi
Lubricant	70 bar	1,015 psi
MQL	10 bar	145 psi
Compressed Air	6 bar	87 psi
Dry run	defined dry run cycles	
Max. Flow	Coolant see table	
Max. Temperature	71 °C	160 °F

** 1116 series: max. 3,500 rpm for compressed air and hydraulic service



DEFINED DRY RUN



MULTI-MEDIA-APPLICATION

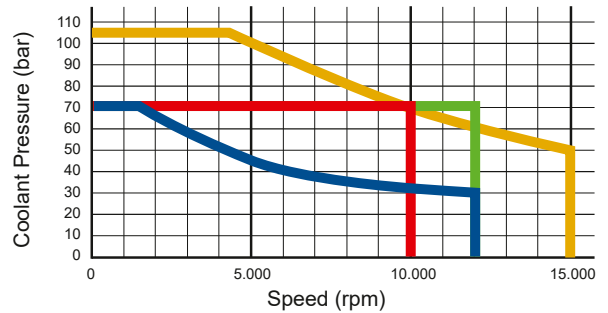

1101-265-644

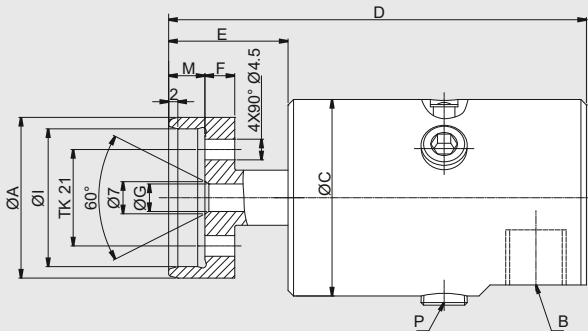

Radial Connection

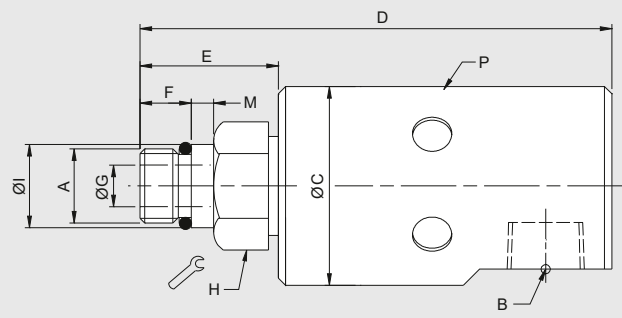

Ordering Number	B Supply Connection	Flow Coolant l/min	D Overall Length	C Overall Diameter	P Drain Size Ø (6 x 60°)	A Rotor Connection	E Rotor Length	F Length	G Bore Diameter	H Across Flats	I Pilot Diameter	M Pilot Length
1005-704-434	1/8 NPT Radial	11	80	34	3 x Rp 1/8	M10 x 1 RH	22	11	3.4	17	10.994 / 10.989	5
1101-265-343	G 1/4 Radial	20	95	43	3 x Rp 1/8	M16 x 1.5 LH	30	11	6	24	17.993 / 17.988	5
1101-265-644	G 1/4 Radial	20	91	43	3 x Rp 1/8	Flange 35 h8	26	6.5	6	4 x M4	30.01 H6	8
1116-516-463*	G 3/8 Radial	82	102	44	6 x 8.5 closed	M16 x 1.5 LH	30	11	8.5	24	17.993 / 17.998	5
1116-063-463*	G 3/8 Axial	82	112	44	6 x 8.5	M16 x 1.5 LH	30	11	9	24	17.993 / 17.998	5
1116-987-463	G 3/8 Radial	82	102	44	6 x 8.5	M16 x 1.5 LH	30	11	8.5	24	17.993 / 17.998	5
1101-202-651*	Rc 3/8	24.3	110	43	3 x Rc 1/8	M16 x 1.5 LH	30	11	6	24	17.993 / 17.988	5
1101-202-664*	Rc 3/8	24.3	110	43	3 x Rc 1/8	M12 x 1.25 LH	30	11	6	24	13.994 / 13.989	5

* Not allowed for operation with hydraulic.