

DC-RINGE



BAUART



Die DC-Ringe sind für den Einsatz mit DC-Klemmkörperkäfigen bestimmt (» siehe Beschreibung vorhergehende Seite).

Die Kombination von Käfigfreilauf und DC-Ringen ergibt einen ungelagerten Freilauf. Der zusätzliche Einbau von Lagern, die axiale und radiale Kräfte aufnehmen, ist erforderlich, ebenso Schmierung und Abdichtung. Die Summe aller Montagetoleranzen darf nicht zum Überschreiten der maximal zulässigen Klemmspalthöhe führen (siehe Tabelle Seite 33).

Die maximale Konizität zwischen den Klemmbahnen beträgt 0,007 mm auf 25 mm Länge. Die Außenringe der Typen »A« und »B« müssen in formstabile Gehäuse eingepresst werden, um eine gute Abstützung zu gewährleisten.

Bitte setzen Sie sich mit unserer Technik in Verbindung, wenn Sie das maximale Freilaufdrehmoment mit der Type »A« und »G« übertragen wollen. Die Belastung der Passfeder ist zu überprüfen.

DC-RINGE

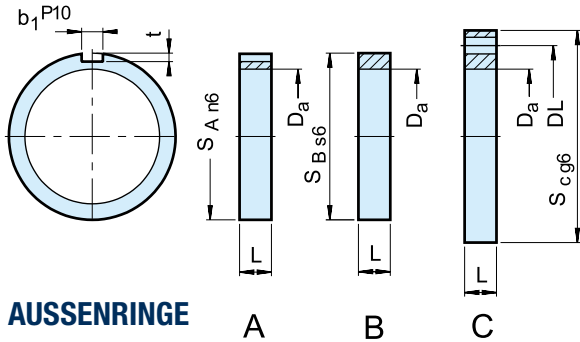

AUSSENRINGE

A

B

C

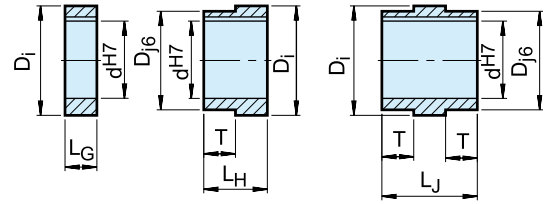

INNENRINGE

G

H

J

1) Passfedernut nach DIN 6885.1

Größe														Lochanzahl x Ø	Passende DC Bauart		
	d ^{H7} [mm]	L _G [mm]	L _H [mm]	L _J [mm]	D _{J6} [mm]	T [mm]	D ₁ +0,008 -0,005 [mm]	L [mm]	S _{An6} [mm]	b ₁ ^{P10}	t	S _{Bs6}	S _{cg6} [mm]	DL ^{±0,1} [mm]	D _a ±0,013 [mm]		
DC 230A								16	72	6	3,5				54,752	DC 3809A	
DC 230B								16				72			54,752		
DC 230C								16					95	78	8 x 7		54,752
DC 230 G-10	10	16					38,092										
DC 230 G-15	15	16					38,092										
DC 230 G-20	20	16					38,092										
DC 230 H-10	10		33		35	17	38,092										
DC 230 H-15	15		33		35	17	38,092										
DC 230 H-20	20		33		35	17	38,092										
DC 230 J-10	10			50	35	17	38,092										
DC 230 J-15	15			50	35	17	38,092										
DC 230 J-20	20			50	35	17	38,092										
DC 167A								16	90	10	5				71,425	DC 5476A DC 5476A (4c)	
DC 167B								16				90			71,425		
DC 167C								16					110	95	8 x 9		71,425
DC 167G-25	25	16					54,765										
DC 167G-30	30	16					54,765										
DC 167G-35	35	16					54,765										
DC 167H-25	25		35		50	19	54,765										
DC 167H-30	30		35		50	19	54,765										
DC 167H-35	35		35		50	19	54,765										
DC 167J-25	25			54	50	19	54,765										
DC 167J-30	30			54	50	19	54,765										
DC 167J-35	35			54	50	19	54,765										
DC 168A								21	110	14	5,5				88,877	DC 7221 (5c) DC 7221B DC 7221B (5c)	
DC 168B								21				110			88,877		
DC 168C								21					140	120	8 x 11		88,877
DC 168G-40	40	21					72,217										
DC 168G-45	45	21					72,217										
DC 168G-50	50	21					72,217										
DC 168H-40	40		42		65	21	72,217										
DC 168H-45	45		42		65	21	72,217										
DC 168H-50	50		42		65	21	72,217										
DC 168J-40	40			63	65	21	72,217										
DC 168J-45	45			63	65	21	72,217										
DC 168J-50	50			63	65	21	72,217										
DC 235A								16	150	20	7,5				119,891	DC 10323A (5c)	
DC 235B								16				150			119,891		
DC 235C								16					190	170	8 x 11		119,891
DC 235G-55	55	16					103,231										
DC 235G-60	60	16					103,231										
DC 235G-75	75	16					103,231										
DC 235H-55	55		43		100	27	103,231										
DC 235H-60	60		43		100	27	103,231										
DC 235H-75	75		43		100	27	103,231										
DC 235J-55	55			70	100	27	103,231										
DC 235J-60	60			70	100	27	103,231										