

ENGINEERING
TOMORROW



Technical Information

Steering

VSPP Steering Unit



Revision history

Table of revisions

Date	Changed	Rev
July 2021	Minor corrections to MMC section	0102
October 2020	First edition	0101

Contents

Overview

A wide range of steering components.....	4
Conversion factors.....	5
Survey of literature with technical data on Danfoss steering components.....	5

Steering unit type VSPP

General.....	6
VSPP.....	6
Load Sensing dynamic steering unit with built in priority valve, VSPP LS.....	6
Non-reaction.....	6
Gear set.....	7
VSPP versions, overview.....	7
VSPP circuits.....	8

Technical data, VSPP LS

Displacement, flow and pressure.....	9
Valve functions.....	10
Pilot pressure relief valve; (P-T, Qp) characteristic.....	11
Check valve function in LS.....	11
Pressure drop, P-EF.....	12
Shock valves.....	12
Suction valves.....	13
Check valve in P.....	13
Weights.....	14

Port thread versions

Dimensions

VSPP.....	16
VSPP dimensions details.....	17

VSPP: Variants and ordering specifications

VSPP MMC.....	18
Variants codes for VSPP MMC.....	19

Overview

A wide range of steering components



Danfoss is one of the largest producers in the world of steering components for hydrostatic steering systems on off-road vehicles. Danfoss offers steering solutions both at component and system levels. Our product range makes it possible to cover applications of all types, ranging from ordinary 2 wheel steering (also known as Ackermann steering) to articulated steering, automatic steering (for example, by sensor) and remote controlled steering via satellite. We can offer more than 1,800 different steering units and 250 different priority valves categorized in types, variants and sizes.

Danfoss offers:

For hydrostatic steering systems:

Product type	Displacement	Rated Flow	Steering Pressure
Mini steering units	32 – 100 cm ³ /rev [1.95 – 6.10 in ³ /rev]	max. 20 l/min [5.28 US gal/min]	max. 150 bar [2180 psi]
Steering units	40 – 1200 cm ³ /rev [2.44 to 73.2 in ³ /rev]	max. 100 l/min [26.4 US gal/min]	max. 240 bar [3481 psi]
Priority valves	-	40, 80, 120, 160, 320 l/min [10.6, 21.1, 31.7, 42.3, 84.5 US gal/min]	max. 350 bar [5076 psi]
Pilot operated flow-amplifiers (factors: 4, 5, 8, or 10)	-	240 and 400 l/min [63.4 and 105.7 US gal/min]	max. 240 bar [3480 psi]
Pilot operated steering valves	-	max. 100 l/min [26.4 US gal/min]	max. 250 bar [3625 psi]

For electrohydraulic steering systems

Product type	Displacement	Rated flow	Steering pressure
Pilot operated steering valves	-	100 l/min [26.4 US gal/min]	250 bar [3625 psi]
Integrated electrical operated steering valve	100 - 500 cm ³ /rev [6.10 - 30.51 in ³]	50 l/min [13.2 US gal/min]	210 bar [3045 psi]
Electrical operated steering valve	-	70 l/min [18.5 US gal/min]	210 bar [3045 psi]

Overview

Characteristic features for steering units:

- Low steering torque: from 0.5 to 3 N·m in normal steering situations
- Low noise level
- Low pressure drop
- Many types available: Open center Non-reaction, Open center Reaction, Power Beyond, Closed center Non-reaction, Load Sensing, Load Sensing Reaction
- One or more built-in valve functions: relief valve, shock valves, suction valves, non-return valve in P-line and LS-line
- Optional port connections according to ISO, SAE or DIN standards

Characteristics for EH steering systems with OSPE, EHPS, and EHi:

- Possibility of GPS, row sensor, variable steering ratio and joystick steering
- Possibility of manual steering even on very heavy vehicles
- EHPS:
 - High steering pressure requiring smaller cylinders and flow
 - Low pilot pressure and flow giving extremely low noise in the cabin
 - Combined with Danfoss PVG 32 proportional valve

Conversion factors

1 N·m = [8.851 lbf·in]

1 N = [0.2248 lbf]

1 mm = [0.0394 in]

1 cm³ = [0.061 in³]

1 l = [0.264 US gal]

1 bar = [14.5 psi]

°F = [1.8°C + 32]

Survey of literature with technical data on Danfoss steering components

Detailed data on all Danfoss steering components and accessories can be found in our steering component catalogues, which is divided into the following individual sub-catalogues:

General information	Steering components
Technical data on mini steering units	OSPM
Technical data on open center and closed center steering units	OSPB, OSPC, and OSPD
Technical data on load sensing steering units, priority valves and flow amplifiers	OSPB, OSPC, OSPF, OSPD, OSPL, OSPBX, OSPLX, OVPL, OLS, and OSQ
Technical data on load sensing steering unit with amplification	OSPU
Technical data on steering units	VSP
Technical data on steering units	VSPP
Technical data on hydraulic and electrohydraulic pilot operated steering valves, electrical actuation modules and appropriate steering units	EHPS, EHPS w. OLS 320, PVE for EHPS and OSPCX
Technical data on combined steering unit/ electrohydraulic steering valves	OSPE
Technical data on electrohydraulic steering valves	EHi
Technical data on steering wheel sensors	SASA

For technical information on individual variants, please contact the Danfoss Sales Organization.

Steering unit type VSPP



General

The VSPP is a steering unit with integrated priority valve inside the envelope of a standard steering unit housing.

This brings about a very compact solution minimizing installation space, cost and time.

VSPP is the perfect solution for smaller vehicles like e.g. low horse power tractors, mini wheel loaders and light fork lift trucks, where one gear pump is in use for steering and working hydraulic.

All VSPP products are black painted as standard.

VSPP

All VSPP's are **High Spec.** for maximum steering pressure 190 bar [2755 psi].

Load Sensing dynamic steering unit with built in priority valve, VSPP LS

The VSPP is a steering unit with integrated priority valve inside the envelope of the standard VSP housing. VSPP LS are all of load sensing dynamic type and so the integrated priority valve is dynamic type.

Spool/sleeve sets for 2 levels of LS dynamic flow are available:

- Standard LS spool/sleeve set: 0.6 - 0.9 l/min [0.16 - 0.24 US gal/min]
- High dynamic LS spool/sleeve set: 1.0 - 1.3 l/min [0.26 - 0.34 US gal/min]

High dynamic is recommended, when extreme fast response is requested, e.g. when unloading working hydraulic load (EF) very rapidly during steering. Trade off with high dynamic is slightly higher energy consumption.

Non-reaction

VSPP's are non-reaction steering units, where there is no movement of the steering wheel, when the driver is not steering the vehicle. The vehicle keeps the steering direction independent of forces on the steering cylinder.

Steering unit type VSPP

Gear set

The gear set meters the volume of oil/revolution on the steering wheel, cm³/rev. 2 versions of gear set are available for VSPP:

- Low Noise is default for VSPP up to and including 250 cm³/rev. VSPP 315 and VSPP 400 will have gear set with standard profile
- Seal star: reduces slippage, when steering cylinder is at end stroke. Seal star gear sets are available in 50, 70, 80, 100 and 125 cm³/rev.

All seal star gear sets have standard profile.

VSPP versions, overview

The VSP's are available in the x-marked combinations:

Type	Spool/sleeve set		Gear set	
	Standard	LS: High dynamic	Low Noise	Seal star
VSPP LS: Load Sensing non reaction w. int. Priority valve	X		X	
	X			X
		X	X	
		X		X

Steering unit type VSPS

VSPS circuits

VSPS Load Sensing dynamic, steering unit with integrated valve functions

VSPS LS Load Sensing Non-reaction

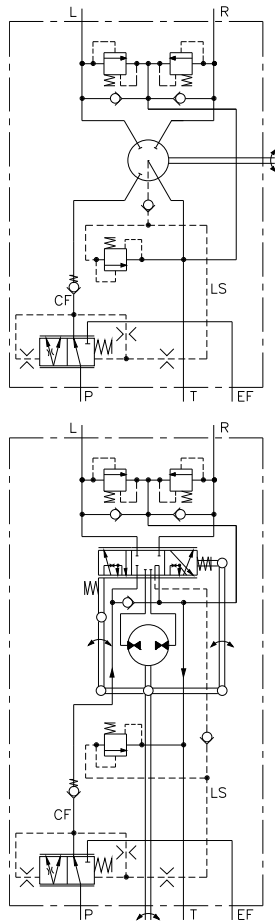

Technical data, VSPP LS

Displacement, flow and pressure

For common data: Look in sub catalog: "General Steering Components"

Steering unit	Displacement cm ³ /rev [in ³ /rev]	Rated oil flow for steering @ 100 rpm l/min [US gal/ min]	Max. oil flow from pump l/min [US gal/ min]	Max. pressure, bar [psi]			
				System pressure ¹ / P-T portpressure	T, absolute port pressure	L-T/R-T port pressure	P and EF, absolute port pressure
VSPP 50 LSH	50 [3.05]	5 [1.32]	80[21.1]	140 [2030]	30 [435]	250 [3625]	230[3335]
VSPP 70 LSH	70 [4.27]	7 [1.85]		170 [2465]			
VSPP 80 LSH	80 [4.88]	8 [2.11]					
VSPP 100 LSH	100 [6.10]	10 [2.64]		190 [2755]			
VSPP 125 LSH	125 [7.63]	13 [3.43]					
VSPP 160 LSH	160 [9.76]	16 [4.23]					
VSPP 200 LSH	200 [12.20]	20 [4.23]					
VSPP 250 LSH	250 [15.26]	25 [6.60]					
VSPP 315 LSH	315 [19.22]	32 [8.45]					
VSPP 400 LSH	400 [24.41]	40 [10.57]					

¹ Any VSPP LSH can withstand 190 bar [2755 psi] in max steering system pressure. However, VSPP w small gear set and high pressure will have relatively high slippage values.

Technical data, VSPP LS

Valve functions

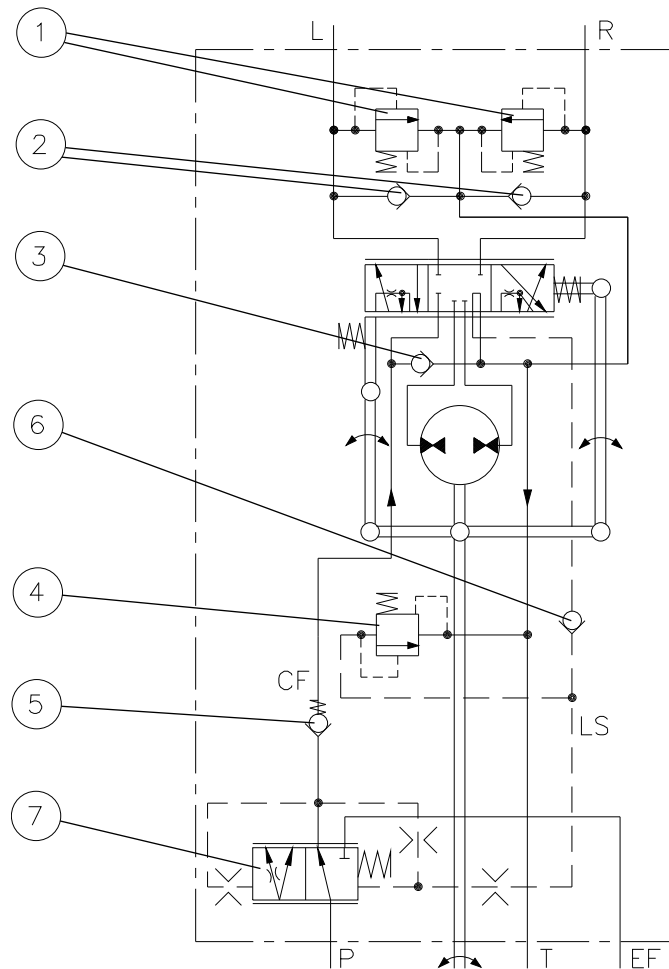

All VSPP LS have the following valves built in:

- Priority valve (7)
- P-Check valve in CF line (5)
- Pilot relief valve (4)
- Check valve in LS (6)
- Emergency steering check valve (3)

All VSPP LS with UNF and Metric ports also have the following valves built in:

- Shock valves (1)
- Suction valves (2)

VSPP LS with G-thread ports can be specified with or without shock and suction valves

Shock and suction are always combined

Technical data, VSPP LS

Pilot pressure relief valve; (P-T, Qp) characteristic

The pilot pressure relief valve protects the steering unit against excessive pressure. The pilot pressure relief valve in the VSPP LS steering unit together with the integrated priority valve spool, limits the maximum steering pressure P-T. The pilot pressure relief valve is set at an oil flow to the P-port of the VSPP valve of 25 l/min [6.60 US gal/min].

For VSPP load sensing dynamic steering units with standard LS spool/sleeve set, the setting values are valid at a dynamic flow of 0.6 l/min [0.16 US gal/min].

For VSPP load sensing high dynamic steering units with low noise/high dynamic spool/sleeve set, the setting values are valid at a dynamic flow of 1.1 l/min [0.29 US gal/min].

Setting tolerance:

</= 170 bar [2465 psi]: rated value +5 bar [72.5 psi].

> 170 bar [2465 psi]: rated value +10 bar [145 psi].

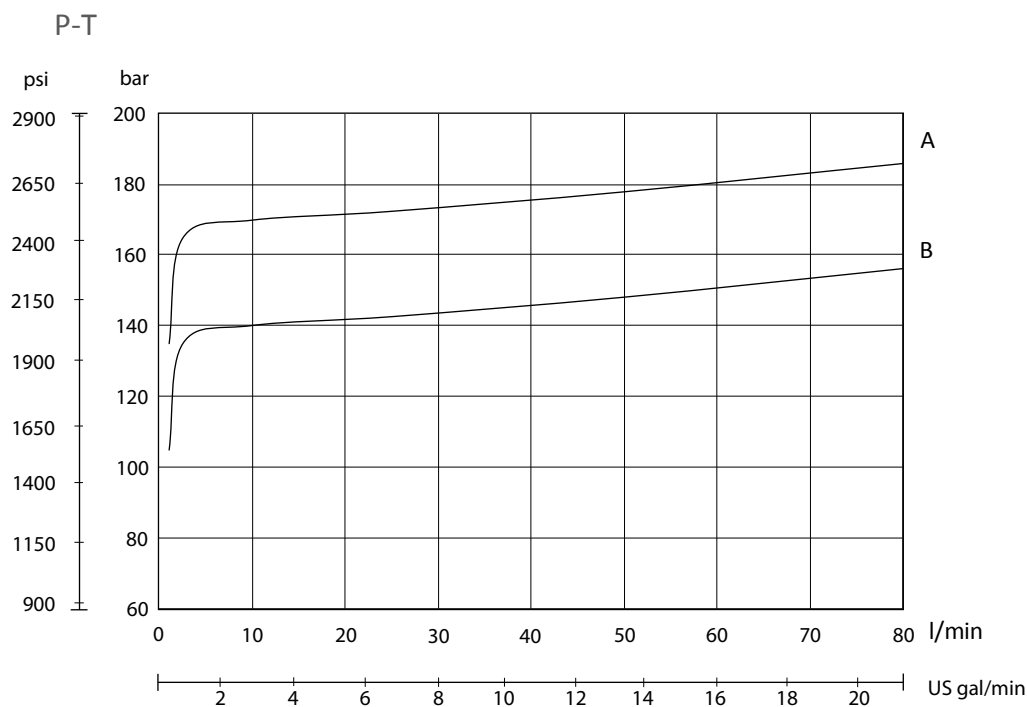

A 170 + 5/-0 bar [2465+ 73/-0 psi]

B 140 + 5/-0 bar [2030 + 73/-0 psi]

Check valve function in LS

The check valve in the LS line of VSPP LS dynamic steering units protects the driver against steering wheel jerks. The check valve prevents oil from flowing backwards into the LS line to the priority valve, when steering against a high pressure on the cylinder side. The need for the LS check valve is very system dependent. It is recommended to be included in VSPP LS up to and including 200 cm³/rev sizes.

Technical data, VSPP LS

Pressure drop, P-EF

This data comes from measurements on a representative sample of VSPP LS w. standard spool/sleeve set. Oil with viscosity of 21 mm²/s at 50 °C [102 SUS at 122 °F] was used during measuring. Measurement made when pressure on the LS connection is zero (steering unit in neutral position). The minimum curves apply when the pressure on the EF connection is higher than the actual control spring pressure. The curves for control spring pressure of 4 or 7 bar [58 or 101 psi] apply when pressure on the EF connection is zero.

Pressure drop, P-EF, for VSPP LS w. standard dynamic LS spool/sleeve set

P-EF, VSPP

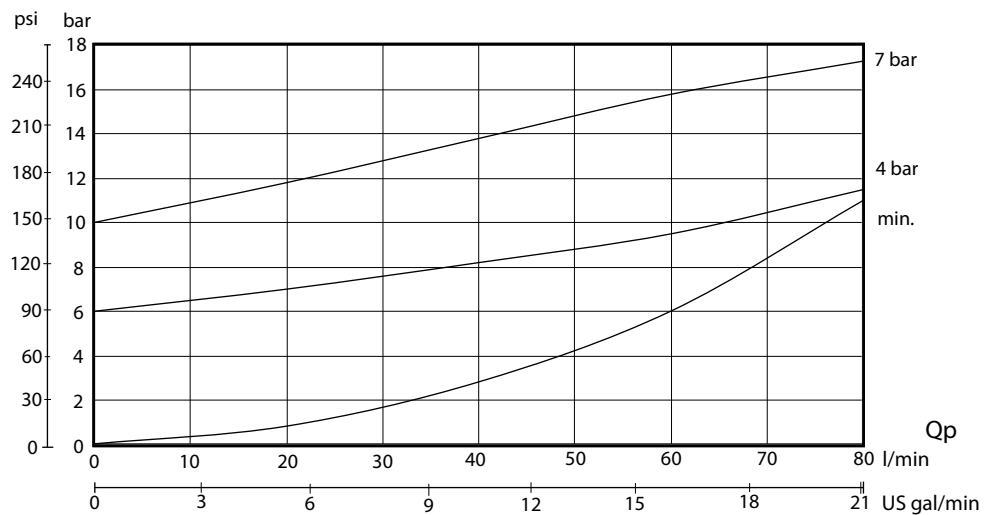

Shock valves

The shock valves protect the steering unit and reduce external forces on the steering cylinder by limiting the pressure difference from L to T and from R to T.

The shock valves are set at 3 l/min [0.792 US gal/min]

At higher flow, pressure peaks may occur.

The shock valves are of the direct acting type, so they react very quickly.

Setting tolerance: rated value +20 bar [290 psi].

Technical data, VSPS LS

Suction valves

The suction valves allow oil suction to avoid cavitation in the steering cylinder. To provide correct suction, a back pressure valve must be fitted in the tank line from the steering unit.

Generally Danfoss recommend a back pressure of 2 bar [29 psi], but on vehicles with strong self-straightening tendencies and on articulated steered vehicles, we recommend 5-10 bar [72.5 - 145 psi]. For further advice, please contact the Danfoss Sales Organisation.

[A connection which incorporates a check valve must be established to allow oil flow to by-pass the back pressure valve \(and filter\) from the tank to steering unit. See diagram examples in sub catalogue "General Steering Components" page 37 - 39.](#)

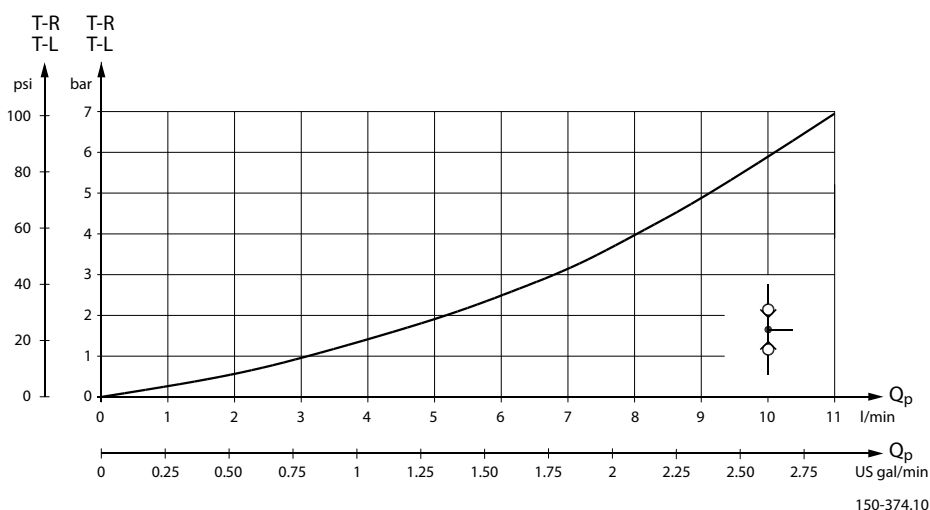

Check valve in P

The check valve in the P connection of the steering unit protects the driver against steering wheel jerks. The check valve prevents oil from flowing backwards into the pump line when steering against a high pressure on the cylinder side. The pressure drop across the check valve is indicated on the following graph, which assumes the use of port adaptors with 11 mm [0.43 in] minimum bore.

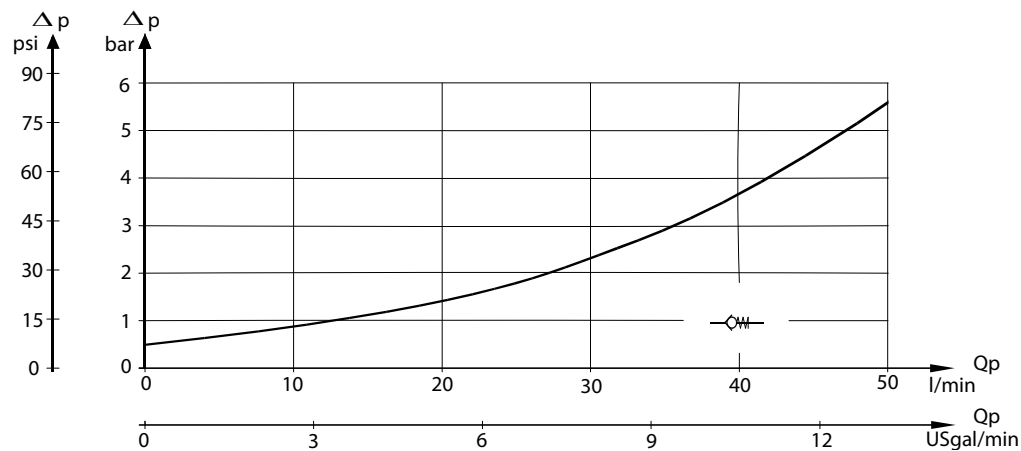

Technical data, VSPP LS

Weights

Type	Weight, kg [lb]
VSPP 50 LS	5.2 [11.46]
VSPP 70 LS	5.3 [11.68]
VSPP 80 LS	5.3 [11.68]
VSPP 100 LS	5.4 [11.90]
VSPP 125 LS	5.5 [12.13]
VSPP 160 LS	5.6 [12.35]
VSPP 200 LS	5.8 [12.79]
VSPP 250 LS	6.0 [13.23]
VSPP 315 LS	6.2 [13.67]
VSPP 400 LS	7.0 [15.43]

Port thread versions

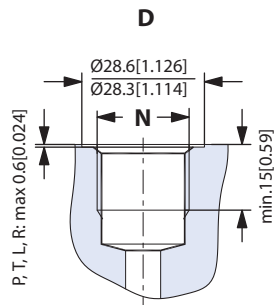

D G port w. spot face (P, T, L, R, EF)

N DIN 3852-2 – G1/2

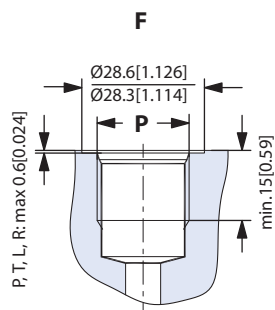

F Metric ports w. spot face and O-ring chamfer (P, T, L, R, EF)

P ISO 6149-1 - M18 x 1.5

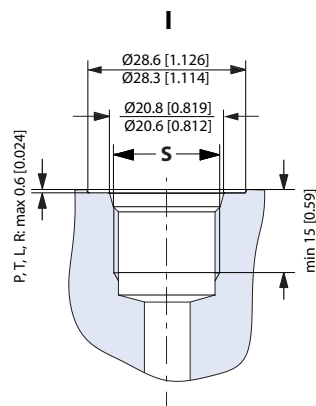

I UNF ports w. spot face and O-ring chamfer (P, T, L, R, EF)

S ISO 11926-1 3/4-16UNF O-ring boss port

Dimensions

VSPS

VSPSLS

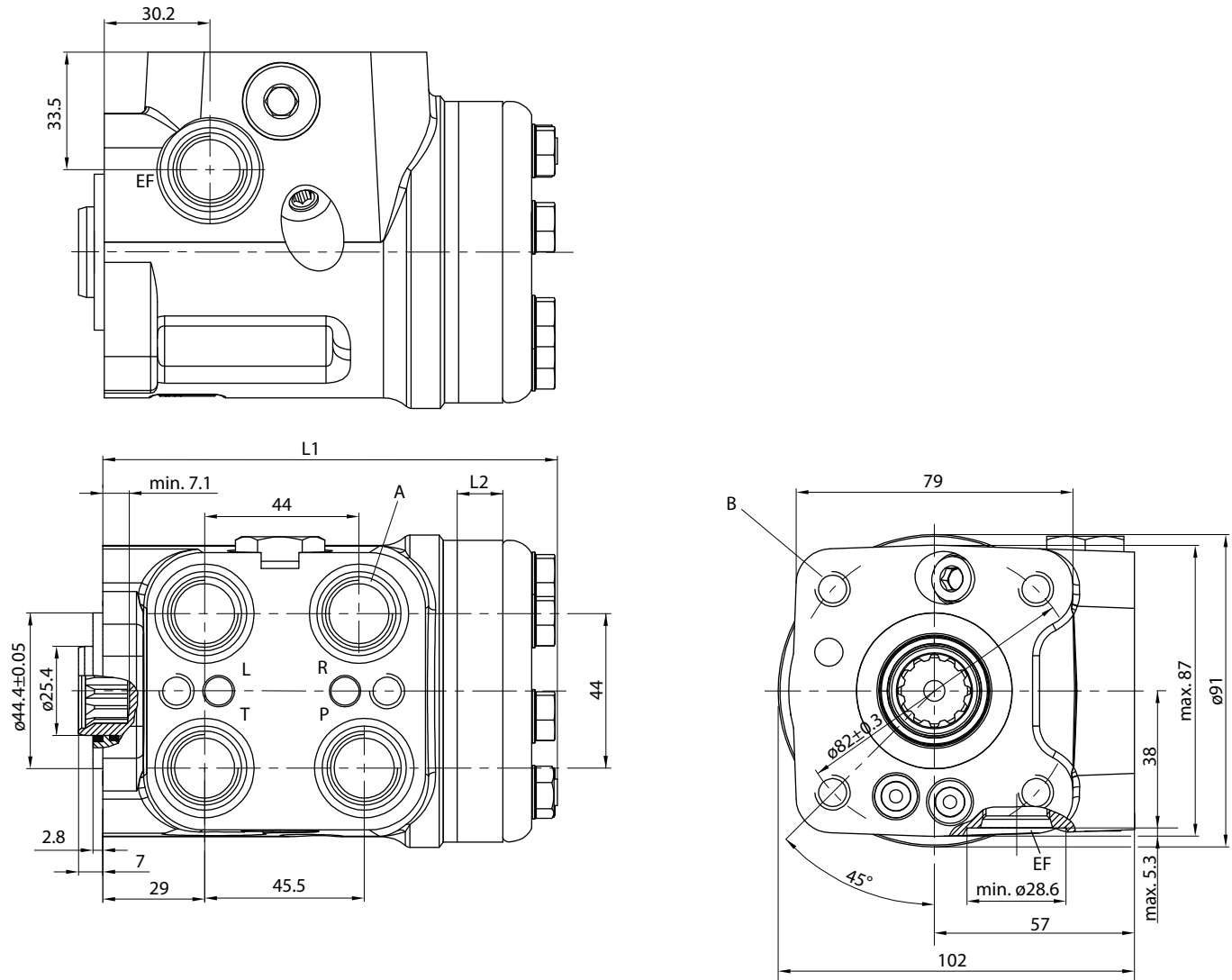

A (P, T, L, R, and EF)

G ½ w. **spot face** (G, DIN 3852-2) 15 mm [0.59 in] deep

Or: M18 x 1.5 ISO 6149-1, 15 mm [0.59 in] deep

Or: 3/4 - 16 UNF O-ring boss ISO 11926-1 15 mm [0.59 in] deep

B

M10 x 1.5, 16 mm [0.63 in] deep

Dimensions

VSPP dimensions details

VSPP dimensions

Type	L1 mm [in]	L2 mm [in]
VSPP 50	125 [4.92]	6.5 [0.26]
VSPP 70	127 [4.99]	9.1 [0.36]
VSPP 80	128 [5.04]	10.4 [0.41]
VSPP 100	131 [5.16]	13.0 [0.51]
VSPP 125	134 [5.28]	16.2 [0.64]
VSPP 160	139 [5.47]	20.8 [0.82]
VSPP 200	144 [5.67]	26.0 [1.02]
VSPP 250	150 [5.91]	32.5 [1.28]
VSPP 315	159 [6.26]	40.9 [1.61]
VSPP 400	170 [6.69]	52.0 [2.05]

VSPP: Variants and ordering specifications

VSPP MMC

Determine Master Model Code (MMC). Fill in with codes from [Variants codes for VSPP MMC](#) on page 19, to specify VSPP steering unit.

MMC-pos.	1	2	3	4	5	6	7
	Type	Displ.	Circuit type	PTL&R size	PTL&R interface	Column thread	EF size
Your VSPP							
Example*	VSPP##	0100	LSH#	UUUU	C	M	H

MMC-pos.	8	9	10	11	12	13	14
	EF interface	EF location	Relief valve	Shock valves	Suction valves	Check valves	Neutral springs
Your VSPP							
Example*	C	9	180	240	1	4	N03

MMC-pos.	15	16	17	18	19
	Spool/sleeve set	Gear set	Special	Label	Paint
Your VSPP					
Example*	SV5	G01	NN	DNFS	PB

* Example is a valid for Catalog code of VSPP 100 LSH: 11189283

VSPP: Variants and ordering specifications

Variants codes for VSPP MMC

MMC pos. 1	Main steering product Type1
VSPP##	VSPP Steering units w. integrated priority valve
MMC pos. 2	Displacement, cm³/rev
0050	50
0070	70
0080	80
0100	100
0125	125
0160	160
0200	200
0250	250
0315	315
0400	400
MMC pos. 3	Circuit type
LSH#	Load Sensing non reaction, High spec.
MMC pos. 4	P, T, L & T Port Size
MMMM	M18x1.5 (ISO 6149-1)
UUUU	3/4"-16 UNF (ISO 11926-1)
GGGG	G1/2" (DIN 3852-2)
MMC pos. 5	P, T, L & T Port Interface
A	O-ring boss + Spot-face (ISO 6149-1)
C	O-ring boss + Spot-face (ISO 11926-1)
E	Spot-face (for G-thread, DIN 3852-2)
MMC pos. 6	Column Thread
M	M10x1,5
MMC pos. 7	EF Port Size
M	M18x1.5 (ISO 6149-1)
H	3/4"-16 UNF (ISO 11926-1)
G	G1/2" (DIN 3852-2)
MMC pos. 8	EF Port Interface
A	O-ring boss + Spot-face (ISO 6149-1)
C	O-ring boss + Spot-face (ISO 11926-1)
E	Spot-face (for G-thread, DIN 3852-2)
MMC pos. 9	EF Port Location
9	On Side

VSPS: Variants and ordering specifications

MMC pos. 10	Relief valve setting
140	Value for setting (140 bar), P-T. All VSPS's have relief valve. Range VSPS: 50 - 190 bar

MMC pos. 11	Shock valves
NNN	No shock valves (only possible for VSPS with G-thread, DIN 3852-2)
200	Value for setting (200 bar), R-T/L-T. Shock and suction valves are belonging Range: 110 - 250 bar, last digit: 0 or 5

MMC pos. 12	Suction valves
N	No suction valves (only possible for VSPS with G-thread, DIN 3852-2)
1	Shock and suction valves are belonging

MMC pos. 13	Check valves
1	Check valve in P (standard)
4	Check valve in P and in LS (standard in LS up to and included 200 ccm/rev)

MMC pos. 14	Neutral Springs
N01	11124634, torque 0.7-1.7 Nm in normal steering situations. Soft
N03	150N4019, torque 0.6-2.5 Nm in normal steering situations. Medium
N05	150-4209, torque 0.8-4 Nm in normal steering situations. Standard

MMC pos. 15	Spool/ Sleeve Set
SV5	LSH: Dynamic flow recommended 0.6-0.9 l/min. Constant pressure. High Spec.
SV6	LSH High dynamic: Dynamic flow recommended 1.0-1.3 l/min. Constant pressure. High Spec.

MMC pos. 16	Gear set
G03	Gear set, Standard cross grinded
G01	Gear set, Low Noise/profile grinded, available up to and including 250 ccm/rev
G04	Gear set, Standard cross grinded, with Seal Star (for low slippage) Available in 50, 70, 80, 100 and 125 ccm/rev

MMC pos. 17	Special
NN	Not Applicable
XX	Special feature

VSPP: Variants and ordering specifications

MMC pos. 18	Label
DNFS	Danfoss name tag
XXXX	Special Label

MMC pos. 19	Paint
PB	Black, Powder, RAL 9005, Corrosion class C3. Standard covering

Products we offer:

- Cartridge valves
- DCV directional control valves
- Electric converters
- Electric machines
- Electric motors
- Gear motors
- Gear pumps
- Hydraulic integrated circuits (HICs)
- Hydrostatic motors
- Hydrostatic pumps
- Orbital motors
- PLUS+1® controllers
- PLUS+1® displays
- PLUS+1® joysticks and pedals
- PLUS+1® operator interfaces
- PLUS+1® sensors
- PLUS+1® software
- PLUS+1® software services, support and training
- Position controls and sensors
- PVG proportional valves
- Steering components and systems
- Telematics

Danfoss Power Solutions is a global manufacturer and supplier of high-quality hydraulic and electric components. We specialize in providing state-of-the-art technology and solutions that excel in the harsh operating conditions of the mobile off-highway market as well as the marine sector. Building on our extensive applications expertise, we work closely with you to ensure exceptional performance for a broad range of applications. We help you and other customers around the world speed up system development, reduce costs and bring vehicles and vessels to market faster.

Danfoss Power Solutions – your strongest partner in mobile hydraulics and mobile electrification.

Go to www.danfoss.com for further product information.

We offer you expert worldwide support for ensuring the best possible solutions for outstanding performance. And with an extensive network of Global Service Partners, we also provide you with comprehensive global service for all of our components.

Local address:

Hydro-Gear

www.hydro-gear.com

Daikin-Sauer-Danfoss

www.daikin-sauer-danfoss.com

**Danfoss
Power Solutions (US) Company**
2800 East 13th Street
Ames, IA 50010, USA
Phone: +1 515 239 6000

**Danfoss
Power Solutions GmbH & Co. OHG**
Krokamp 35
D-24539 Neumünster, Germany
Phone: +49 4321 871 0

**Danfoss
Power Solutions ApS**
Nordborgvej 81
DK-6430 Nordborg, Denmark
Phone: +45 7488 2222

**Danfoss
Power Solutions Trading
(Shanghai) Co., Ltd.**
Building #22, No. 1000 Jin Hai Rd
Jin Qiao, Pudong New District
Shanghai, China 201206
Phone: +86 21 2080 6201

Danfoss can accept no responsibility for possible errors in catalogues, brochures and other printed material. Danfoss reserves the right to alter its products without notice. This also applies to products already on order provided that such alterations can be made without subsequent changes being necessary in specifications already agreed. All trademarks in this material are property of the respective companies. Danfoss and the Danfoss logotype are trademarks of Danfoss A/S. All rights reserved.