

Centrifugally Lift Off Sprags Freewheels

RSXM

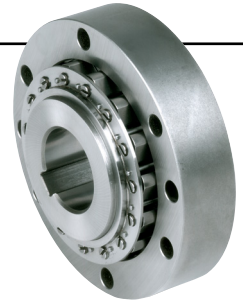

TYPE



The series RSXM completes the small to medium backstop range, which commenced with the highly successful RSCI programme. Type RSXM is a centrifugal lift off sprag type freewheel with the inner race rotating. Only the inner race is designed for freewheeling. It is a non self-supported type. Bearings must be provided to ensure concentricity of the inner and outer races and support axial and radial loads, as shown overleaf. Concentricity and run-out limits must be observed.

The RSXM type accepts all types of lubricant currently used in power transmission equipment. It is possible to mount these freewheels directly in gearboxes without separate lubrication. An oil mist is generally sufficient. Grease lubrication may be acceptable if the unit works mostly in overrunning condition, as on E-motors. When used as a backstop, it must be checked that the overrunning speed will not go below the minimum speed given in the characteristic table.

Centrifugally Lift Off Sprags Freewheels

RSXM

RSXM

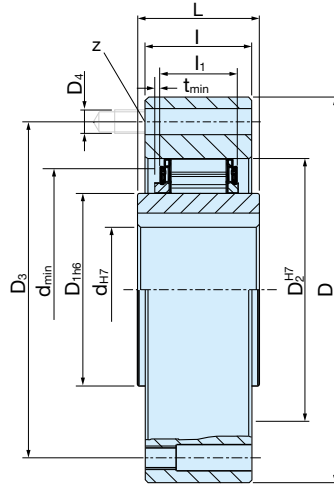

Type	Size	Bore dia.	Torque	Overrunning speeds						Number						Weight		
		d^{H7} [mm]	$T_{KN}^{1)}$ [Nm]	$n_{max}^{2)}$ [min ⁻¹]	$n_{min}^{3)}$ [min ⁻¹]	$n_{imax}^{4)}$ [min ⁻¹]	$D^{5)}$ [mm]	D_{1h6} [mm]	D_2^{H7} [mm]	D_3 [mm]	D_4 [mm]	z [nb]	L [mm]	l [mm]	l_1 [mm]	t_{min} [mm]	d_{min} [mm]	[kg]
RSXM	31	20*	100	340	820	20000	85	31	55	70	M6	6	24	25	17	1	41	0,75
	38	25*	135	320	770	18500	90	38	62	75	M6	6	24	25	17	1	50	0,95
	46	25,30	425	300	530	13500	95	46	70	82	M6	6	35	35	25	1	53	1,4
	51	30,35	525	220	525	12500	105	51	75	90	M6	6	35	35	25	1	62	1,8
	56	35,40	625	210	500	11500	110	56	80	96	M6	8	35	35	25	1	70	1,8
	61	35,40	420	265	640	14000	120	61	85	105	M8	6	25	27	17	2	73	1,8
	66	35,40,45	850	200	480	10000	132	66	90	115	M8	8	35	35	25	1	78	2,7
	76	40,45,50	1100	190	460	9000	140	76	100	125	M8	8	35	35	25	1	90	3,1
	86	45,50	1450	180	440	8000	150	86	110	132	M8	8	40	40	25	1	100	4,2
	101	45,55,60,70	1950	175	420	6500	175	101	125	155	M10	8	50	50	25	1	117	7,3

NOTES

- 1) $T_{max} = 2 \times T_{KN}$
» Refer to Selection page 7 to 11
 - 2) This maximum allowable torque transmission speed n_{max} must not be exceeded when transmitting torque.
 - 3) This minimum allowable overrunning speed n_{min} should not be reduced under continuous operation. Possible reduction of this minimum speed in request.
 - 4) Inner race overruns.
Keyway to DIN 6885.1
*Keyway to DIN 6885.3
 - 5) Tolerance +1
- » Refer to mounting and maintenance instructions page 12 to 13.

Other bore diameters on request.

MOUNTING EXAMPLE

