

HMV/HSV Series



- 4GA/B
- M4GA/B
- MN4GA/B
- 4GA/B (master)
- 4GB With sensor
- 4GD/E
- M4GD/E
- MN4GD/E
- 4GA4/B4
- MN3E
- MN4E
- W4GA/B2
- W4GB4
- MN3S0
- MN4S0
- 4SA/B0
- 4KA/B
- 4KA/B (master)
- 4F
- 4F (master)
- PV5G
- GMF
- PV5
- GMF
- PV5S-0
- 3Q
- MV3QR
- 3MA/B0
- 3PA/B
- P/M/B
- NP/NAP
- NVP
- 4G*0EJ
- 4F*0EX
- 4F*0E
- HMV
- HSV
- 2QV
- 3QV
- SKH
- Silencer
- TotAirSys (Total Air)
- TotAirSys (Gamma)
- Ending

JIS symbol

● HMVC2, H SVC2
(All ports closed)

Switching position 1 N 2

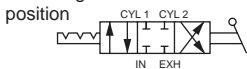

● HMVO2, H SVO2
(ABR connection)

Switching position 1 N 2

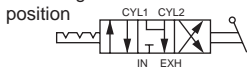

Common specifications

Item	HMV ₀ ^C 2	HSV ₀ ^C 2				
Valve and operation	Rotary sliding valve					
Working fluid	Compressed air					
Max. working pressure	MPa	0.97 (≈140 psi, 9.7 bar)				
Min. working pressure	MPa	0 (≈0 psi, 0 bar)				
Proof pressure	MPa	1.5 (≈220 psi, 15 bar)				
Ambient temperature	°C	5 (41°F) to 50 (122°F)				
Fluid temperature	°C	5 (41°F) to 50 (122°F)				
Lubrication	Not required					
Degree of protection	Dust-proof					
Operating angle	°	90				
Port size	Rc	1/4	1/4	3/8	1/2	3/4
Weight	kg	0.7	2.0	1.9	1.9	1.8

Flow characteristics

Model No.	Port size	IN→CYL1/CYL2		CYL1/CYL2→EXH	
		C[dm ³ /(s·bar)]	b	C[dm ³ /(s·bar)]	b
HMV ₀ ^C 2	1/4	1.5	0.31	1.6	0.28
	3/8	7.2	0.74	7.2	0.73
HSV ₀ ^C 2	3/8	10.2	0.32	10.1	0.34
	1/2	10.0	0.32	10.2	0.33
	3/4	10.3	0.36	10.2	0.36

*1 : Effective cross-sectional area S and sonic conductance C are converted as S ≈ 5.0 x C.

How to order

● Miniature

HMV C 2 - 8 - 4 H

● Standard

HSV C 2 - 10 - 4 H

A Model No.

B Solenoid position

C Port size

D Piping

A Model No.		HMV	HSV
Code	Description		
B Solenoid position			
C	3-position all ports closed	●	●
O	3-position ABR connection	●	●
C Port size			
8	Rc1/4	●	●
10	Rc3/8		●
15	Rc1/2		●
20	Rc3/4 (vertical piping not available.)		●
D Piping			
H	Side piping	●	●
V	Vertical piping (not compatible with a port size of Rc 3/4.)	●	●

Internal structure and parts list

HMVC2-8-4H HSVC2-8 to 20-4H

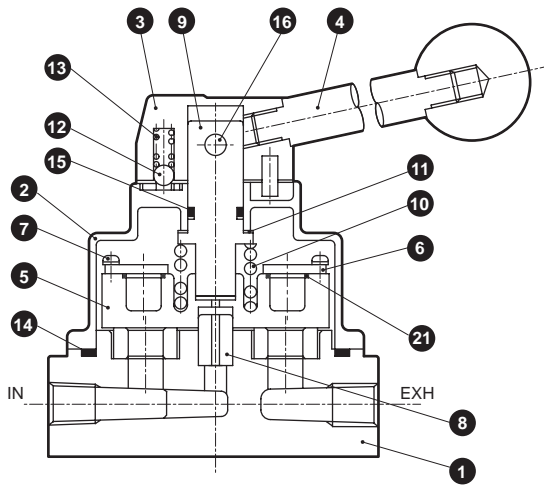

HMVO2-8-4H HSVO2-8 to 20-4H

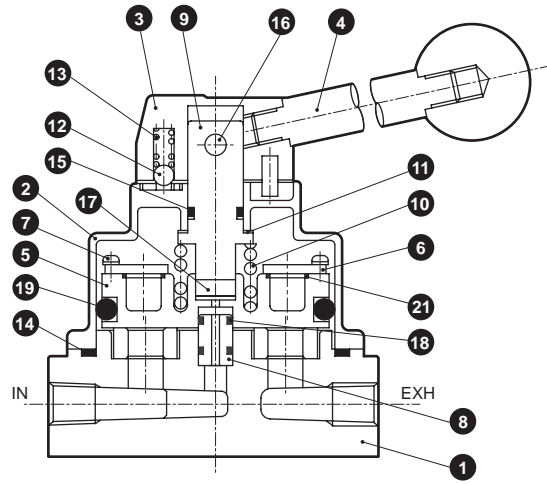

HMVC2-8-4V HSVC2-8 to 15-4V

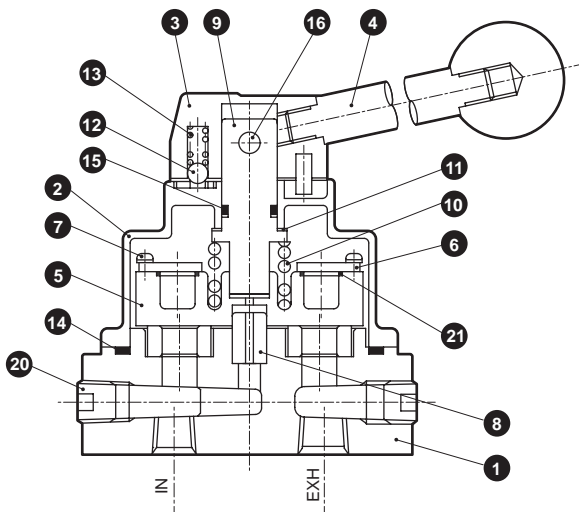

HMVO2-8-4V HSVO2-8 to 15-4V

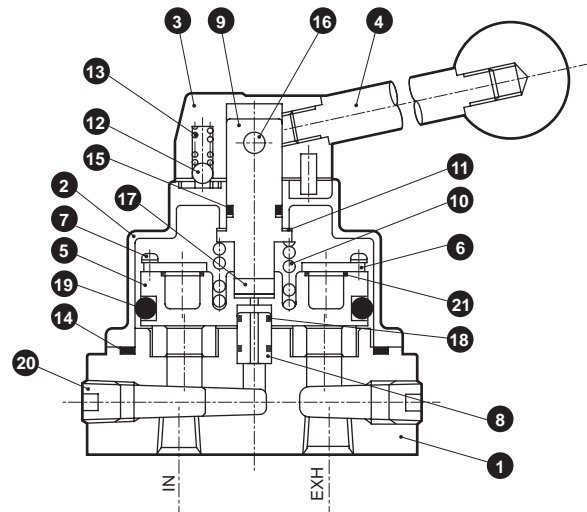

Main parts list

No.	Part name	Material	No.	Part name	Material
1	Body assembly	Zinc alloy die-casting tetrafluoroethylene resin (other than port size 20)	11	Washer	Special polyethylene
			12	Ball	Stainless steel
			13	Spring	Stainless steel
		Aluminum alloy die-casting tetrafluoroethylene resin (port size 20 only)	14	O-ring	Nitrile rubber
			15	O-ring	Nitrile rubber
			16	Pin	Steel
2	Cover assembly	Zinc alloy die-casting	17	Spindle guide	Steel (HSVO2 only)
3	Handle head	Zinc alloy die-casting	18	O-ring	Nitrile rubber
4	Handle assembly	Steel, urea resin	19	O-ring	Nitrile rubber
5	Slide ring	Zinc alloy die-casting	20	Hexagon socket head cap plug	Steel
6	Plate	Steel	21	Gasket	Nitrile rubber
7	Cross-recessed tapping screw	Steel			
8	Rod	Steel			
9	Spindle	Stainless steel			
10	Spring	Piano wire			

4GA/B
M4GA/B
MN4GA/B
4GA/B (master)
4GB With sensor
4GD/E
M4GD/E
MN4GD/E
4GA4/B4
MN3E MN4E
W4GA/B2
W4GB4
MN3S0 MN4S0
4SA/B0
4KA/B
4KA/B (master)
4F
4F (master)
PV5G GMF
PV5 GMF
PV5S-0
3Q
MV3QR
3MA/B0
3PA/B
P/M/B
NP/NAP NVP
4G*0EJ
4F*0EX
4F*0E
HMV HSV
2QV 3QV
SKH
Silencer
TotAirSys (Total Air)
TotAirSys (Gamma)
Ending

HMV/HSV Series

Dimensions

- 4GA/B
- M4GA/B
- MN4GA/B
- 4GA/B (master)
- 4GB With sensor
- 4GD/E
- M4GD/E
- MN4GD/E
- 4GA4/B4
- MN3E MN4E
- W4GA/B2
- W4GB4
- MN3S0 MN4S0
- 4SA/B0
- 4KA/B
- 4KA/B (master)
- 4F
- 4F (master)
- PV5G GMF
- PV5 GMF
- PV5S-0
- 3Q
- MV3QR
- 3MA/B0
- 3PA/B
- P/M/B
- NP/NAP NVP
- 4G*0EJ
- 4F*0EX
- 4F*0E
- HMV HSV**
- 2QV 3QV
- SKH
- Silencer
- TotAirSys (Total Air)
- TotAirSys (Gamma)
- Ending

HMVC2-8-4H,4V
HMVO2-8-4H,4V

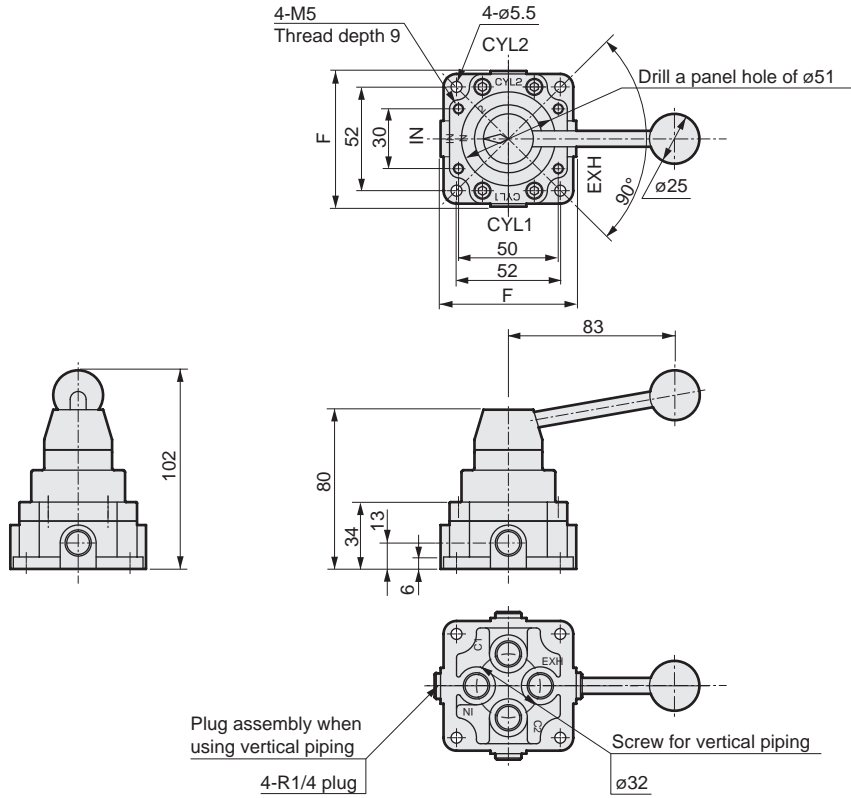

HSVC2-8 to 20-4H, 4V
HSVO2-8 to 20-4H, 4V

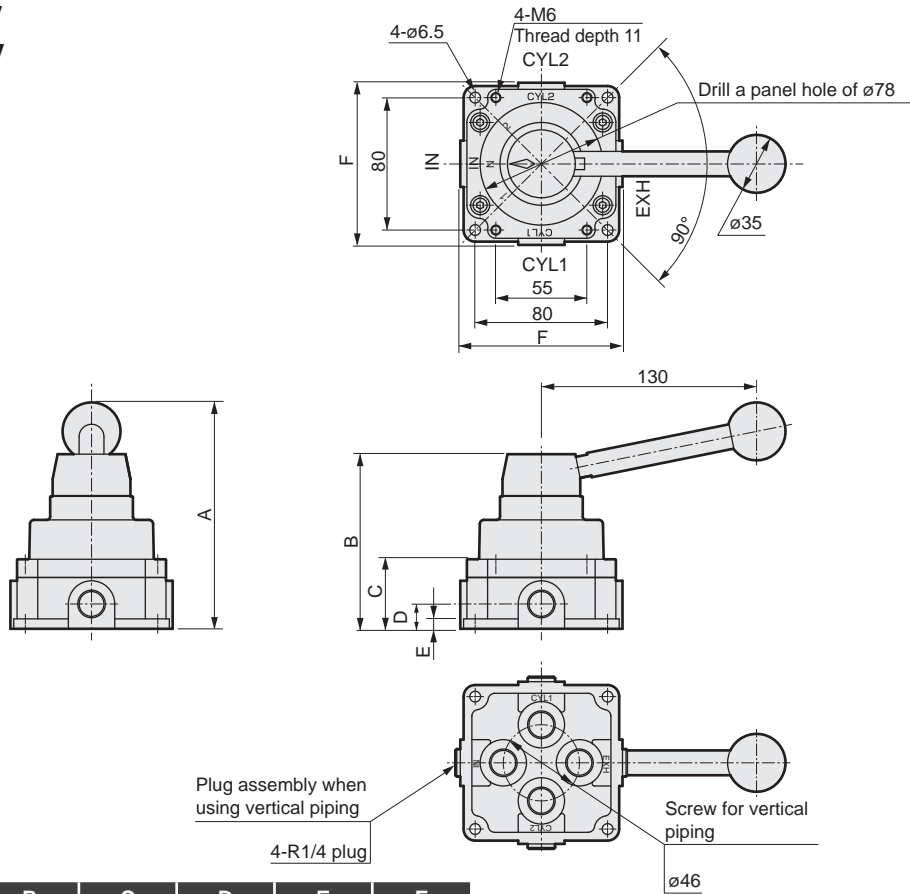

Model No.	A	B	C	D	E	F
HMV*2-8-4H						68
HMV*2-8-4V						74
HSV*2-8 to 15-4H	132	105	42	15	6	98
HSV*2-8 to 15-4V	132	105	42	15	6	104
HSV*2-20-4H	137	110	47	18	10	98