

Data Sheet

EC-LTS1200-410

Liquid cooled heavy duty inductor unit

FEATURES

- Extremely compact design – 410 A unit only 23 kg
- High enclosure class IP67 – sealed from moisture and dust
- Liquid cooled with water-glycol mixture
- Ambient temperature from -40°C to +105°C
- Allowed coolant temperature up to +65°C
- Robust design withstanding high levels of mechanical vibrations and shocks
- Designed especially for highly cyclical loads typical in heavy mobile work machines
- Three temperature sensors included for temperature surveillance



GENERAL

The device is a heavy duty external inductance unit designed to be combined with EC-C1200 DC/DC-converter. It allows flexible positioning of the DC/DC-converter and inductor unit and is used to transfer energy between two different voltage levels.

TYPICAL APPLICATIONS

- Boosting battery voltage to higher DC-link voltage
- Charging high voltage batteries from higher DC-link voltage

SPECIFICATIONS

DC connection	
DC link voltage range	0-850 V _{DC}
DC link nominal voltage	750 V _{DC}
Nominal current	410 A total (+65°C coolant, 8 kHz interleaved switching frequency)
Inductance per inductor	165 µH (at nominal current)
Resistance per inductor	11 mΩ

Mechanical	
Dimensions (W x H x L)	403 x 147 x 262 mm 403 x 147 x 287 mm (with +CG1 option)
Weight	23 kg
Main materials	Enclosure (including coolant circuit): AISi12Cu1 (Fe) Coolant connections: CuZn39Pb3

Cooling	
Cooling liquid	Plain water with appropriate corrosive inhibitor (max. 50 % corrosive inhibitor)
Cooling liquid glycol type	Ethylene glycol (Glysantin G48 recommended)
Minimum cooling liquid flow	10 l/min
Maximum continuous pressure	2 bar
Coolant volume	390 cm ³
Pressure loss	40 mbar with 10 l/min (+25°C coolant)
Cooling liquid temperature	-40°C ... +65°C

Ambient Conditions	
Storage temperature	-40°C...+105°C
Operating temperature	-40°C...+105°C (with nominal coolant temp.)
Absolute maximum inductor temperature	+160°C (Measured by the units PT100 sensors)
Altitude	max. 4000 m
Relative humidity	100 %
Enclosure class	IP67
Mechanical vibration	5.91G _{RMS} ISO 16750-3 Test VII – Commercial vehicle, sprung masses – Table 12 Notes: test duration 8h axis (three axes tested; x, y and z axis) total spectral acceleration 5.91G _{RMS} 5 G, CEI EN 61373 category 2 IEC 60068-2-6 (2007-12, Test Fc) 10...57 Hz: amplitude 0.075 mm 58...150 Hz: 1 G 5...24.9 Hz: ±1.6 mm 24.9...100 Hz: 4G (sinusoidal)
Mechanical shock	50 G ISO 16750-3 4.2.2 Test for devices on rigid points on the body and on the frame Notes: –acceleration: 500 m/s ² ;

	–duration: 6 ms; –number of shocks: 10 per test direction (x, y and z axis, both directions, 6x directions in total) 30 G, CEI EN 61373 category 2
--	--

Connections	
Coolant connection	2 x G3/4" coolant hose connector (see dimension drawing for details)
HV cable recommended type	HUBER+SUHNER Radox Elastomer S, screened, single core, automotive cable (FHLR4GC13X) www.hubersuhner.com
HV cable cross section	≤70 mm ² (Cu) (M25 cable gland) ≤120 mm ² (Cu) (M32 cable gland)
HV cable glands (with +CG1 option)	3x Pflitsch blueglobe TRI bg 225ms tri 3x Pflitsch blueglobe TRI bg 232ms tri 2x M32 plugs For more information on configurable cable glands, see Table 3.
HV cable lug	35-8, 50-8, 70-8, 95-8, 120-8
Recommended cable lug	35 mm ² : Druseidt with narrow flange 03901 50 mm ² : Druseidt with narrow flange 03903 70 mm ² : Druseidt with narrow flange 03906 95 mm ² : Druseidt with narrow flange 03910 (only compatible with M32 cable gland) 120 mm ² : Druseidt with narrow flange 03914 (only compatible with M32 cable gland) www.druseidt.de
Temperature measurement	3x PT100 temperature sensors, one per inductor
Temperature sensor connector + insert + pins	M16 male, 7.840.200.000 Insert 10-pole, 7.003.910.101 Sensor Connector Pin, 7.010.981.001 www.hummel.com
Temperature sensor mating connector + insert + socket	M16 female, 7.810.400.000 Insert 10-pole, M16, RCPT, 7.003.910.102 Sensor Connector Socket, 7.010.981.002 www.hummel.com

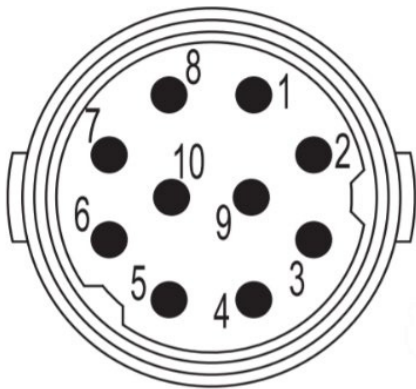

Figure 1 Temperature measurement connector pinout

PIN	Description
1	Temperature 1, PT100 (P), inductor
2	Temperature 1, PT100 (N), inductor
3	Temperature 2, PT100 (P), inductor
4	Temperature 2, PT100 (N), inductor
5	Temperature 3, PT100 (P), inductor
6	Temperature 3, PT100 (N), inductor
7	Enclosure ground (shield)
8	Reserve

Table 1 Pin configuration of temperature measurements (M16 connector, one sensor per inductor)

PRESSURE LOSS VS COOLANT FLOW

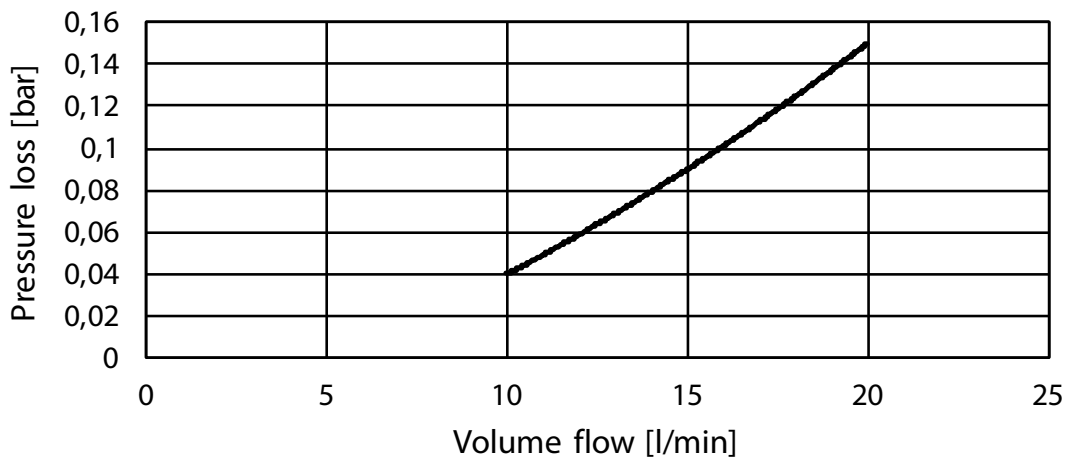

Figure 2 Device pressure loss vs coolant flow

DIMENSIONS

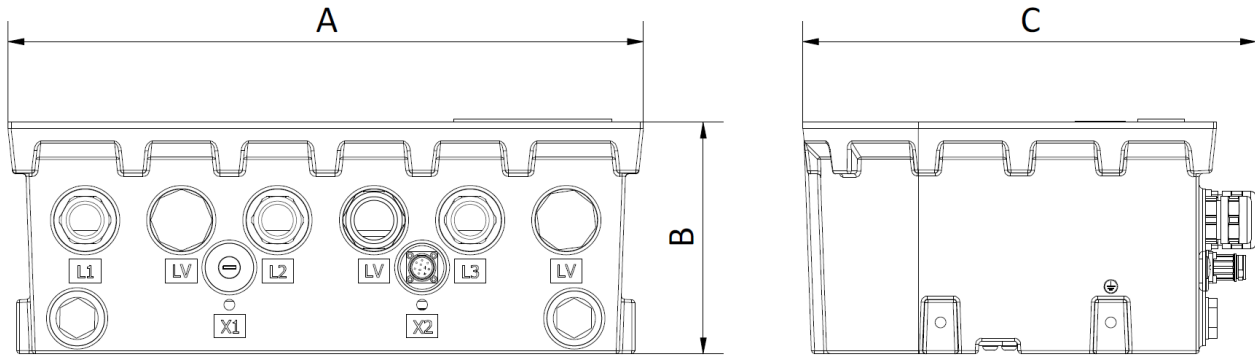

Figure 3 Device dimensions with +CG1 option (example cable gland configuration, 3x M25, 1x M32 cable glands and 2x M32 plugs)

Dimension	Length
A	403 mm
B	147 mm
C	287 mm

Table 2 Device dimensions with +CG1 option

APPLICATION EXAMPLE

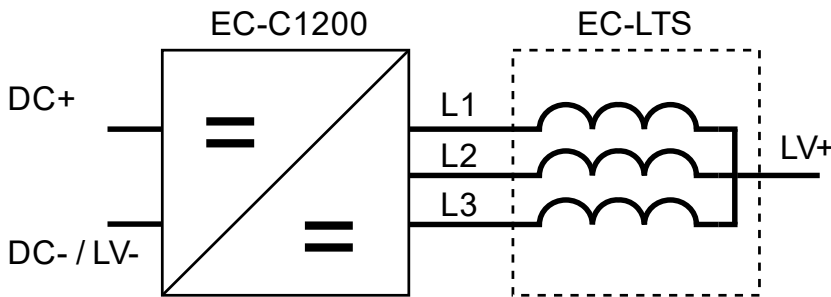

Figure 4 EC-C1200 DC/DC converter combined with the EC-LTS unit

LV+ and LV- can be connected, for example, to battery and DC+ and DC- to DC-link. EC-C1200 would then control the battery discharging and charging.

LTS1200 has internal parallel busbar included for low voltage (LV) side inductors. With internal parallel connection 1 to 3 output (LV+) cables can be used depending on the cable gland configuration. Typical cable gland configurations can be seen in the table below.

Connections	Typical cable gland combinations		
	Connection to DC/DC-converter (L1, L2, L3)	3x M25 cable glands	3x M25 cable glands
Low voltage side positive connection (+LV)	1x M32 cable gland, 2x M32 plugs	2x M32 cable glands, 1x M32 plugs	3x M32 cable glands, no plugs

Table 3 Typical cable gland configurations for LTS1200 (cable glands and plugs are included in the delivery with +CG1 option for any of these configurations)

PRODUCT CODE AND OPTIONS

Use the product code including all needed options for ordering. Standard options do not need to be listed in the code as they are selected by default if a non-standard option is not selected. Standard options are indicated by a star (*).

EC-LTS is designed to be used in combination with the EC-C inverters.

Product code	Description
EC-LTS1200-410	Standard unit without cable glands or plugs
EC-LTS1200-410+CG1	Unit with all necessary cable glands included for free configuration of power connections

Table 4 Product code examples

Variant	Code	Description	Additional information
Cable glands	*	No cable glands	No cable glands or plugs
	+CG1	M25/M32 cable glands	3x M25 cable glands, 3x M32 cable glands and 2x M32 plugs in delivery
Marine classification	*	No marine classification	
	+CL1		ABS American Bureau of Shipping
	+CL2		BV Bureau Veritas
	+CL3		DNV
	+CL4		LR Lloyd's Register
	+CL5		RINA
	+CL6		CCS China Classification Society

*Standard option

Table 5 Option list

Danfoss can accept no responsibility for possible errors in catalogues, brochures and other printed material. Danfoss reserves the right to alter its products without notice. This also applies to products already on order provided that such alterations can be made without changes being necessary in specifications already agreed. All trademarks in this material are property of the respective companies. Danfoss and the Danfoss logotype are trademarks of Danfoss A/S. All rights reserved.