

Partner for Performance

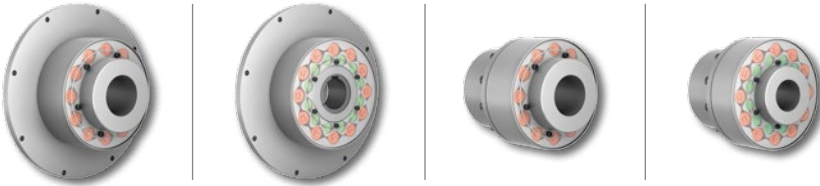

# Torsional Highflex Couplings



RINGFEDER® TNR

EN 08.2019

Product Paper & Tech Paper



# Welcome

---



Machine Building



Aerospace



Process



Movement



Energy



Extraction



## Your system supplier for every aspect of power transmission

**We say what we mean and mean what we say.**

**We see things from our customers' perspective.**

**We are considerate of our employees and their families as well as of our environment and society.**



RINGFEDER POWER TRANSMISSION is the global market leader in the niche markets of drive technology and is well regarded for its customer-specific, application-oriented solutions that ensure excellent and failure-free operation for its clients. We offer locking devices, damping technology and couplings for OEMs but also for the final customer under our strong brand name RINGFEDER®.

We do not only provide competent advice to our customers on the basis of our 90 years of experience but also develop innovative ideas in cooperation with them. This is part of our aspiration to be a **Partner for Performance**.

### Around the power transmission we promise

- Excellent know-how for our challenging customers
- Best cost-benefit ratio
- Short reaction times and a high product availability





## Know-how

Over 90 years of expertise.

## On-site worldwide

We are there for you. Anytime, anywhere.

## Your expert partner

From development to the finished product.

Customer

Value

## Online calculation program

Always find the right solution.

# Your projects are our drive

## **Know-how:** Over 90 years of expertise.

---

Rely on decades of engineering expertise from the inventor of the friction spring. As an expert in drive and damping technology, we are your reliable partner wherever forces are at work. Be it the permanent transfer of very high torques due to non-positive or positive connections or the absorption and trapping of extreme energies to protect expensive constructions.

## **Your expert partner:** From development to the finished product.

---

We accompany you through to the successful completion of your project. Beginning with the development phase of your project, we offer our know-how and professional solutions. By working together with global market leaders and as an international supplier of outstanding products and special solutions, we are a reliable partner for you.

## **Online calculation program:** Always find the right solution.

---

In response to the complex requirements involved in the correct selection and design of the required products under practical conditions, we have developed our online calculation program. Engineers and experts are able to calculate transferable torques and other important values, taking into account various parameters. Visit our website [www.ringfeder.com](http://www.ringfeder.com)!

## **On-site worldwide:** We are there for you. Anytime, anywhere.

---

With our locations in Germany, the Czech Republic, the USA, Brazil, China and India as well as a worldwide service and partner network, we are there for you around the clock. This ensures our support for the successful completion of your projects at any time.

# RINGFEDER®

## Torsional Highflex Couplings

### Introduction



**RINGFEDER® TNR**, the novel non-switchable coupling with adjustable dynamic parameters and unchanging outer dimensions. The torsionally flexible coupling can move in all directions, adjusting for angular, axial and radial shaft misalignment between coupled machines.

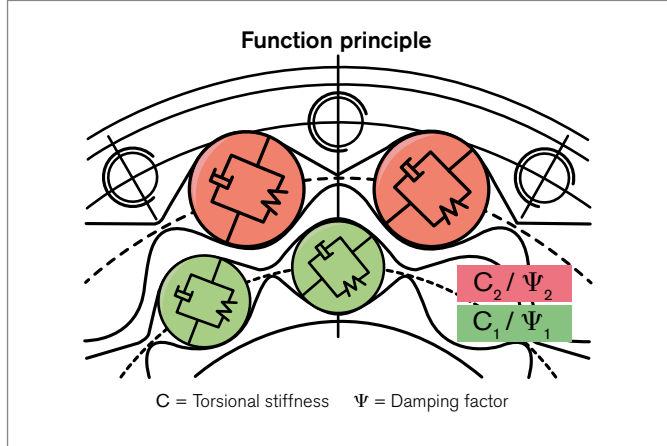

Fig. 1: Basic principle: Series arrangement of elastic buffers

### Adjustable rigidity

Using combustion engines such as diesel and gas engines, but also other machines and plant generating undesirable torsional vibrations, the drive train is subject to dynamic excitations. Unavoidable resonances will occur should engine-side excitation frequencies and the resonance frequency of the drive train coincide. These may be shifted from the desired range of operating speed range towards less critical frequencies by specific adjustments to the coupling rigidity, resulting in markedly smoother running. The smoothest running is often achieved in the hypercritical region, i.e. after passing through the resonances, which may be achieved through the use of highly elastic couplings.

Single-row coupling designs in the RINGFEDER® TNR series already exhibit rigidities similar to those of conventional, highly flexible rotationally elastic couplings, especially for higher torques. The RINGFEDER® TNR range double-row coupling design furthermore allows adjustment of the dynamic properties without much effort. This is made possible over a wide range by the serial arrangement of the elastic buffers (see Figure 1), with constant external dimensions.

		
<b>RINGFEDER® TNR 2424.1</b>	<b>RINGFEDER® TNR 2424.2</b>	<b>RINGFEDER® TNR 2425.1</b>
Single-row, SAE flange-shaft connection	Double-row, SAE flange-shaft connection	Single-row, SAE flange-shaft connection and taper lock bushing
		
<b>RINGFEDER® TNR 2425.2</b>	<b>RINGFEDER® TNR 2428.1</b>	<b>RINGFEDER® TNR 2428.2</b>
Double-row, SAE flange-shaft connection and taper lock bushing	Single-row, shaft-shaft connection	Double-row, shaft-shaft connection

#### Disclaimer of liability

All technical details and notes are non-binding and cannot be used as a basis for legal claims. The user is obligated to determine whether the represented products meet his requirements.

We reserve the right carry out modifications at any time in the interests of technical progress.

## Shifting the resonance position

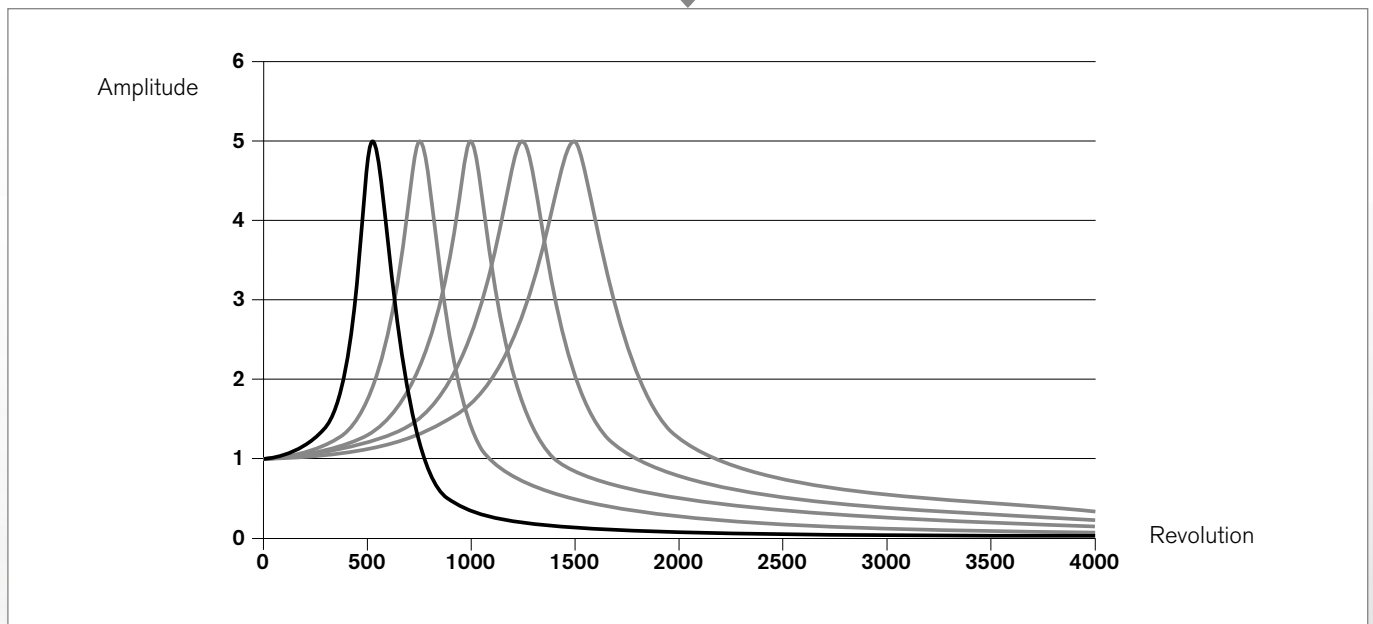
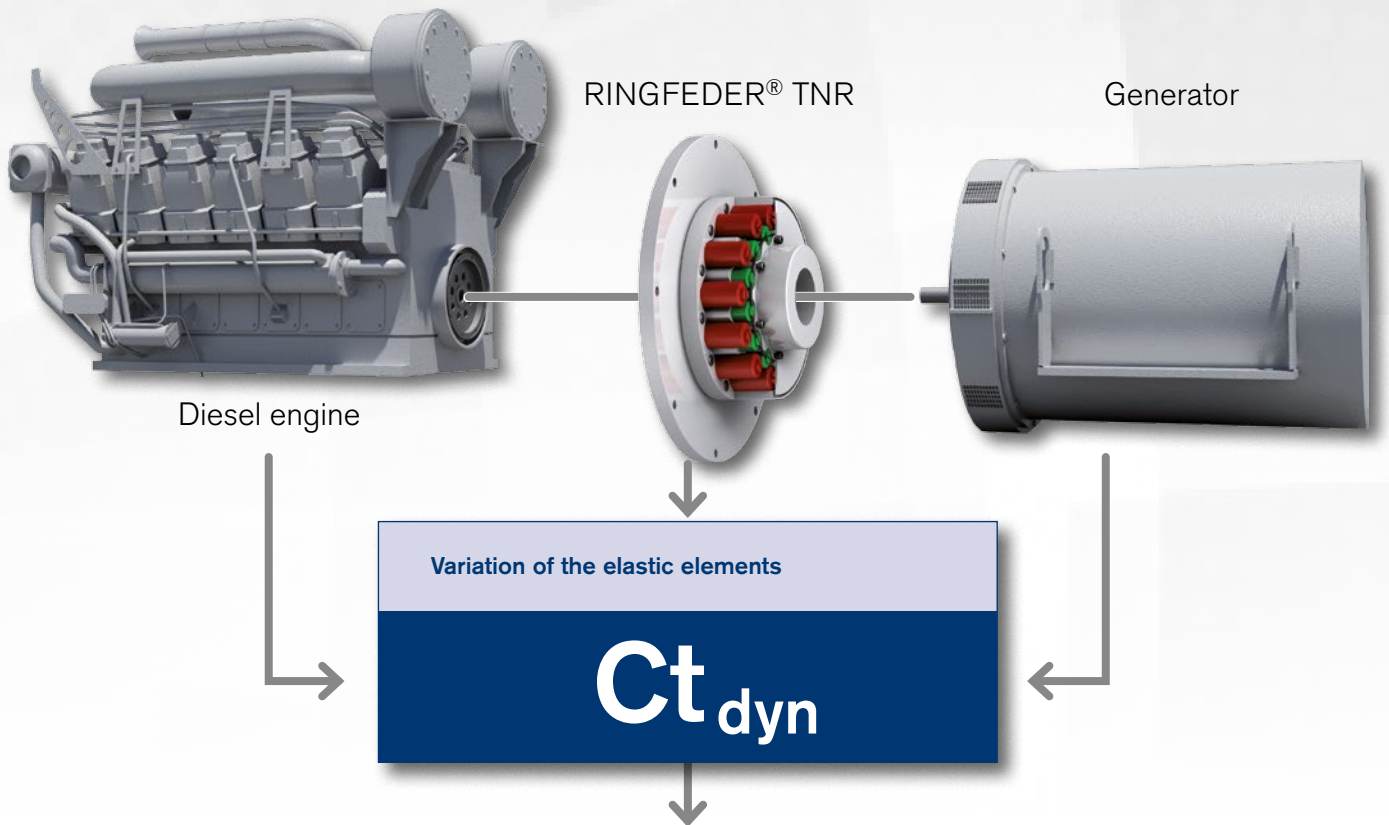

Fig. 2: Interaction of stiffness changes and resonance speeds demonstrated on a diesel engine driven generator

As demonstrated in Figure 2, the effects of resonances may be shifted to lower speeds by reducing the dynamic coupling stiffness without changing the connected dimensions. Hyper-critical opera-

tion is possible and optimal running smoothness is achieved by adjusting the stiffness of coupling through judicious selection of elastic buffers.

# Torsional characteristic

The stress the functional principle of the RINGFEDER® TNR imposes on the elastic buffers causes high torsional displacement and thereby a soft characteristic with little progressivity in the single row design which, as opposed to linear characteristic couplings, also has a positive effect on smooth running.

The properties of the couplings are easy to change with the RINGFEDER® TNR, to easily and optimally match the stiffness to the drive train.

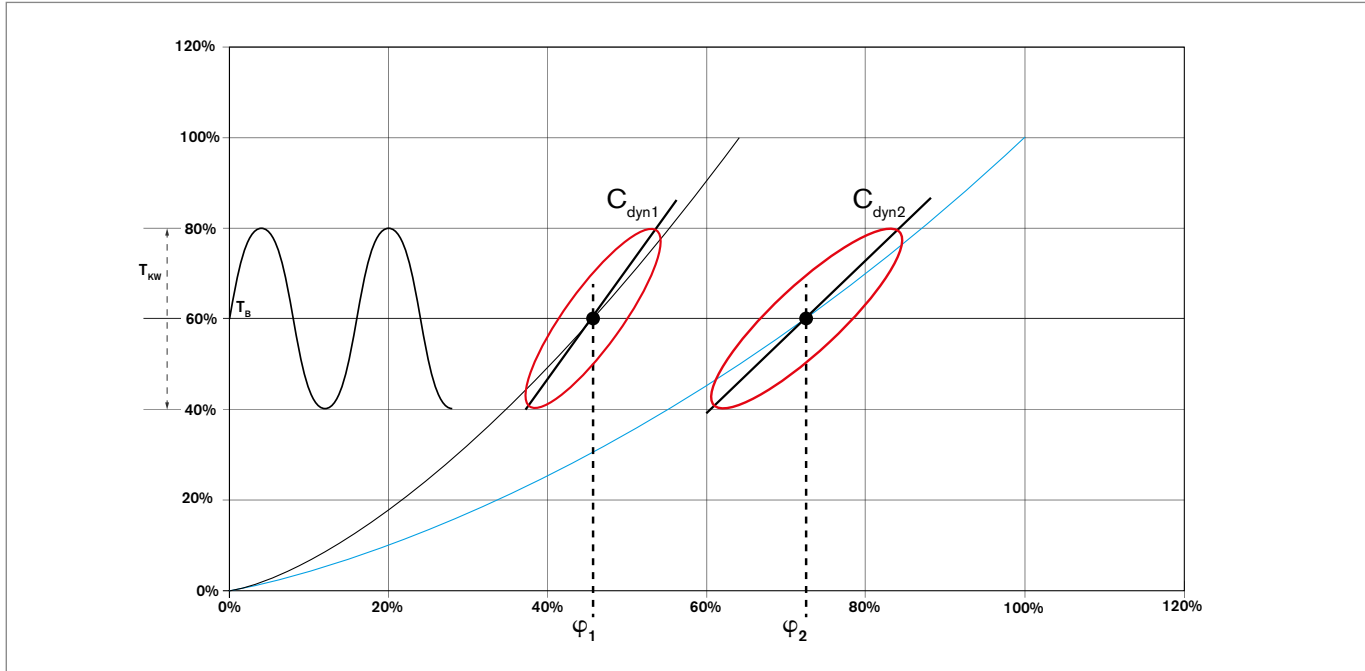

Fig. 3: Torsional characteristic for the single ( $C_{dyn1}$ ) and double-row ( $C_{dyn2}$ ) RINGFEDER® TNR

## Functional principle

Coupling hub and housing have special meshed gears. The relative torsional displacement under load causes the elastic buffer to roll in the gear teeth, whereby the free buffers will in the initial phase experience shear stress and then compressive stress at nominal torque. The elasticity and damping properties of the buffers together with the stress created by the special shape of the teeth lend the coupling its low torsional stiffness and excellent damping effect.

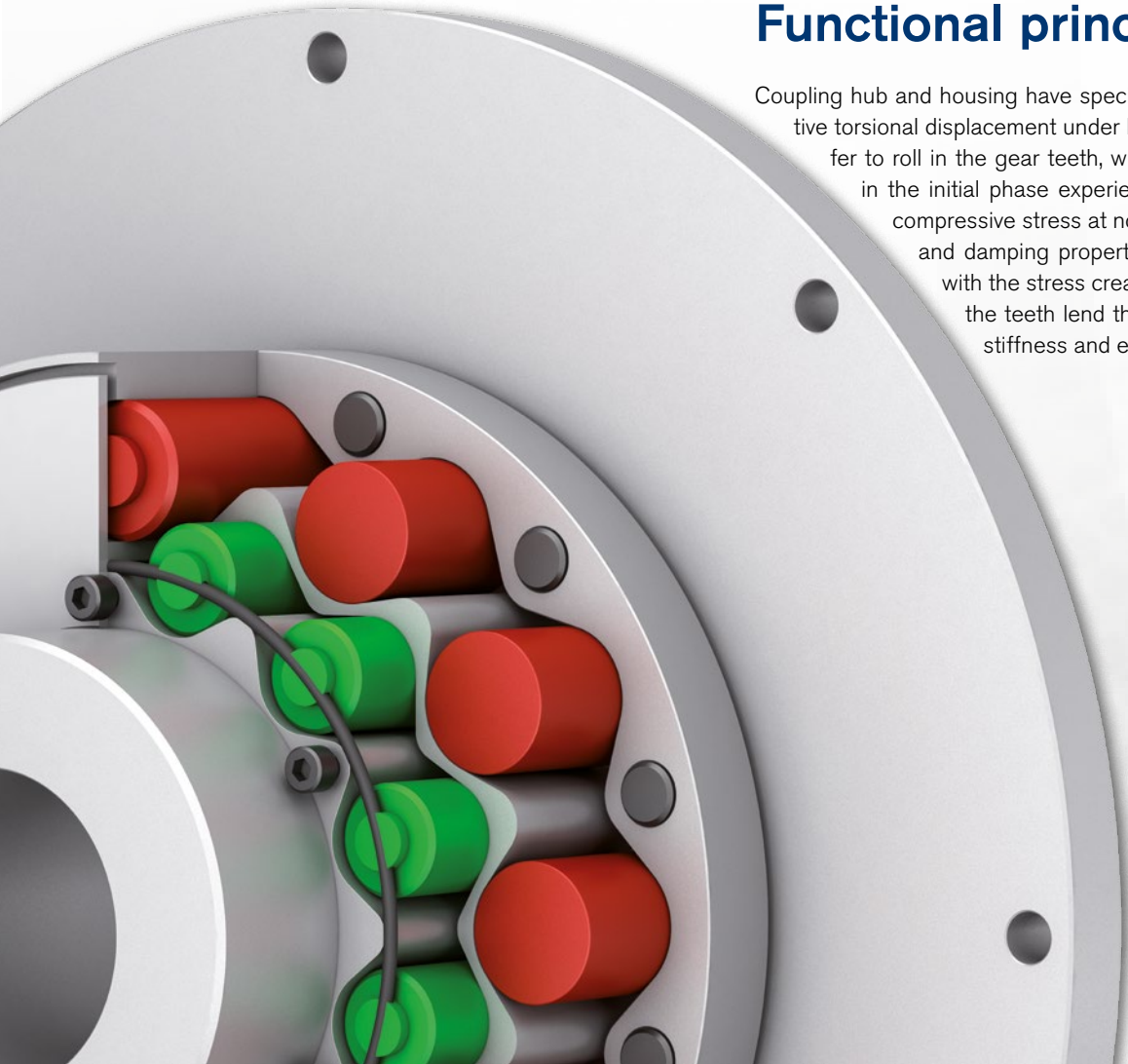
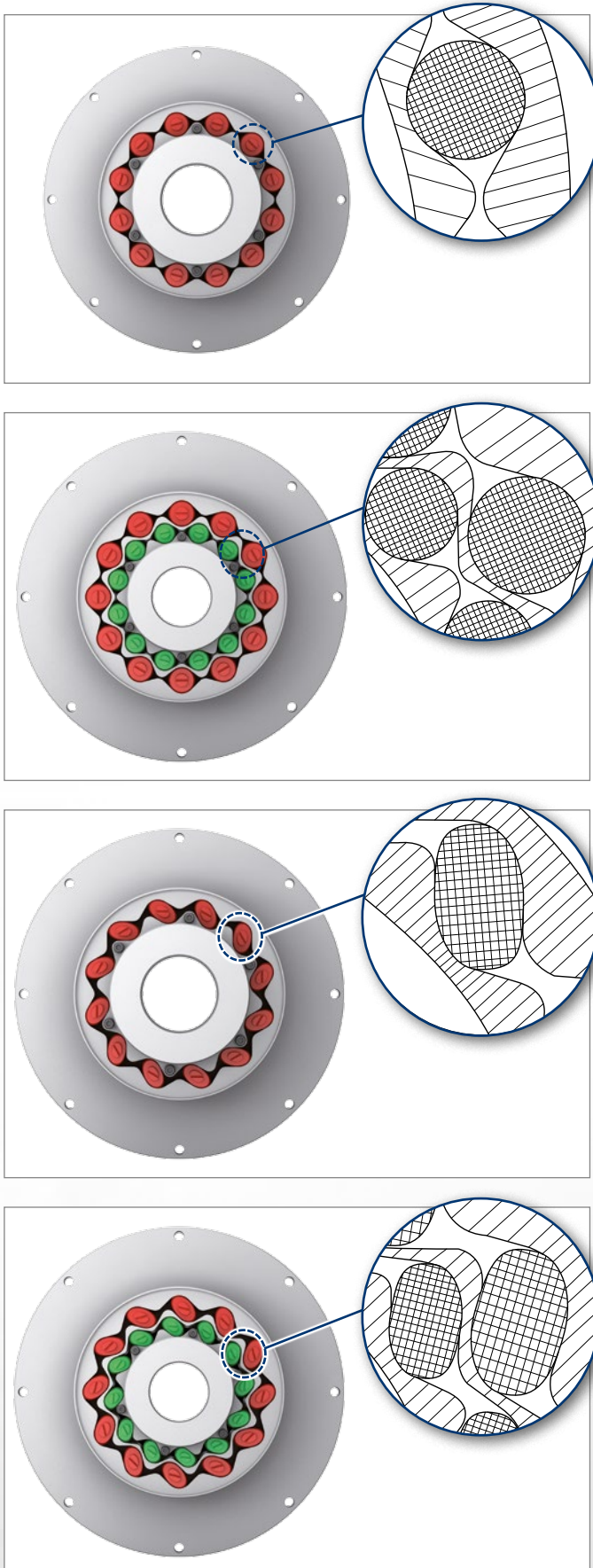



Fig. 4: Functional principle of the RINGFEDER® TNR.1 and the RINGFEDER® TNR.2



### Buffer materials

Synthetic rubbers and a variety of polyurethanes of different hardness are used for the elastic TNR coupling buffers. The product range is supplemented by special materials for low and high temperatures to render reliable solutions under extreme environmental conditions. The catalogue includes data for standard combinations of the specific materials and customised solutions may be found on demand, with little effort required. The shore hardness of each elastomeric material is the indication of its load bearing capacity. These values allow indirect estimates of the transmissible torques for the coupling and its spring constant. Consult the technical data sheet for additional detail.

### Environmental conditions

The elastomeric materials used are suited for ambient temperatures between  $-50\text{ °C}$  to  $+130\text{ °C}$ . For higher ambient temperatures, please enquire with us. The design guidelines below explain the effect of temperatures on the correct size of couplings. The coupling is for use only in normal industrial air. Aggressive media are a danger to reliable operation of the coupling, since they could attack components of the coupling such as screws and elastic elements.

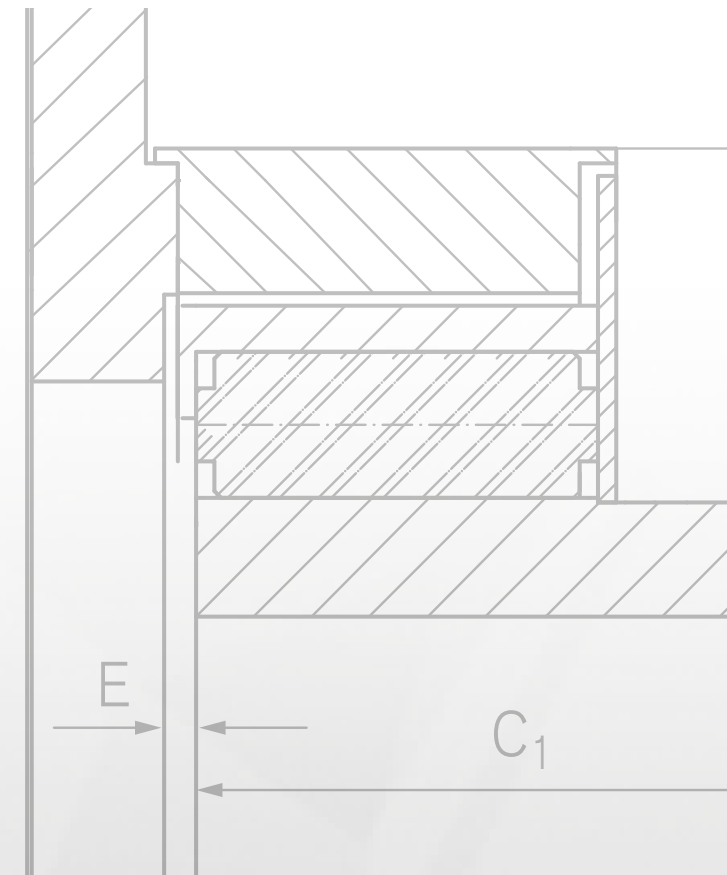



Drive side	Minimum load factor $S_A$
E-Motor, turbine	1
Hydraulic motor	1,1
Combustion machine 4 and more cylinders, U-degree $\leq$ 1:100	1,2 (DSR)*
Combustion machine 1 to 3 cylinders, U-degree $>$ 1:100	1,4 (DSR)*

$S_A$  = Load factor of drive side:  
We recommend for drivers with combustion machines to examine by a 'DSR' - torsional vibration calculation which coupling is suitable for the application!

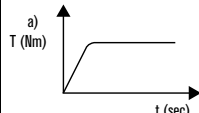
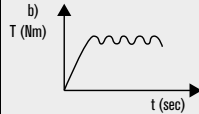
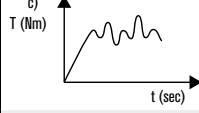
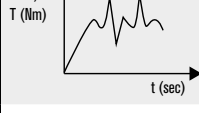
Torque characteristics at operating point on outside	Torque characteristics	Minimum load factor $S_L$
Constant, uniform, without torque variation	a) 	1
Uniform with little variations, slight shocks	b) 	1,25
Non-uniform, also API-671, API-610, moderate shocks	c) 	1,5
Non-uniform, fluctuant, heavy shocks	d) 	1,75
Other torque characteristics		Own specification/ personal vibration calculation

$S_L$  = Load factor of output side

Ambient temperature range [°C]	Temperature factor $S_\theta$ for intermediate ring materials			
	PB	Vk	HT	TT
-50 < $\vartheta$ < -30	-	-	-	1,2
-30 < $\vartheta$ < +40	1	1	1	1
+40 < $\vartheta$ < +60	1	1,2	1	1,2
+60 < $\vartheta$ < +80	1	1,4	1	1,4
+80 < $\vartheta$ < +100	1,2	-	1,2	1,8
+100 < $\vartheta$ < +130	-	-	1,4	-

$S_\theta$  = Temperature factor depending on intermediate ring materials

# Dimensioning of coupling

The dimensioning of the elastic RINGFEDER® couplings is based on the nominal torque  $T_N$  and maximum impact torque  $T_{max}$  of the machines.

Equation 1)

$$T_N = 9550 \cdot P_N / n_N$$

$T_N$	= Nominal torque of machine	[Nm]
$P_N$	= Machine power	[kW]
$n_N$	= Operating speed	[min <sup>-1</sup> ]

The following equation applies when subjected to the nominal torque:

Equation 2)

$$T_{KN} > T_N \cdot S_\vartheta \cdot S_f$$

$T_{KN}$	= Nominal torque of coupling	[Nm]	acc. to Paper data
$T_N$	= Nominal torque of machine	[Nm]	acc. to equation (1)
$S_\vartheta$	= Temperature factor	[-]	according to table
$S_f$	= Service factor	[-]	$S_A \cdot S_L$
$S_A$	= Load factor of drive side		
$S_L$	= Load factor of output side		

Verifying the maximum torque of the coupling:

The following equation applies for transient impact torques, which occur e.g. by starting an electric motor:

Equation 3)

$$T_{Kmax} > T_{max} \cdot S_\vartheta \cdot S_Z$$

$T_{Kmax}$	= Maximum torque of the coupling	[Nm]	acc. to Paper data
$T_{max}$	= Maximum impact torque of machine	[Nm]	

\* e.g. when starting an electric motor:  $T_{max} = T_{Kipp}$   
 $T_{Kipp}$  = Tipping torque by starting with directly engaged asynchronous motor e.g.  
 $T_{Kipp} \sim 2,5 \cdot T$ ; observe details of motor producer

Start-ups per hour	Start-up factor $S_Z$
< 120	1
120 - 240	1,3
>240	On request

$S_Z$  = Start-up factor

## Check selected coupling size

■ Check whether the **hub bore** is able to accommodate the shaft diameters. The values of the maximum finish bores stated in the tables are applicable for keyed connections according to DIN 6885/1 and must not be exceeded.

■ Check the power transmission capability of the **shaft-hub-connection**. The nominal torques stated in the tables will be reliably transmitted by the couplings. The introduction of the torque into the coupling hub has to be verified by the user of the coupling according to recognized rules of technology. If necessary, the second key is to be offset by 180°.

■ Observe the **maximum permissible speed** of the coupling.

■ Check whether **balancing** is necessary.

We advise to balance the coupling parts or sub assemblies if the circumferential speed at the outer diameter exceeds 22 m/s. Balancing can only be performed on couplings with finish-bores. Unless otherwise specified, the half-key convention applies, so that the coupling hubs are balanced prior to producing the keyways.

# Dimensioning example

Example for dimensioning a coupling for a pump drive with electric motor type IEC 355; preselected type: RINGFEDER® TNR (Single-row).

Coupling size TNR 320.1 with buffer quality Vk90 and 8500 Nm nominal coupling torque are selected from the Tech Paper data

sheet. The dimension of coupling TNR 320.1 is OK for the performance data. The operating speed of 1480 rpm results in a circumferential speed of 24,8 m/s. Therefore it is recommended to balance the coupling parts. If the shaft-hub connections are dimensioned sufficiently, this coupling can be used.

Input power $P_N =$	355 kW	
Operating speed $n_N =$	1480 rpm	
Nominal torque $T_N =$	$9550 \cdot P_N / n = 9550 \cdot 355 / 1480 = 2291 \text{ Nm}$	acc. to equation 1)
Ambient temperature $\vartheta =$	65 °C	
→ Temperature factor $S_\vartheta =$	1,4	for Vk90
Load factor		
Drive motor	Directly engaged asynchronous motor ( $\Delta$ -connection)	
→ Load factor of drive side $S_A =$	1	
Working machine	Centrifugal pump - torque characteristics uniform with little variations, skight shocks	Figure 2 (page 7)
→ Load factor of output side $S_L =$	1,25	
Required nominal torque of the coupling $T_{KN} >$	$T_N \cdot S_\vartheta \cdot S_f = 2291 \text{ Nm} \cdot 1,4 \cdot 1,25 = 4009 \text{ Nm}$	acc. to equation 2)

## Verifying the maximum torque of the coupling

Maximum torque $T_{max} = T_{max} = T_{Kipp} =$ Tipping torque when starting with directly engaged asynchronous motors	$2,5 \cdot T_N = 2,5 \cdot 2291 \text{ Nm} = 5727,5 \text{ Nm}$	
Ambient temperature $\vartheta =$	65 °C	
→ Temperature factor $S_\vartheta =$	1,4	for Vk90
Starts per hour	6	
→ Start-up factor $S_z =$	1	for Vk90
Required maximum torque of the coupling $T_{Kmax} >$	$T_{max} \cdot S_\vartheta \cdot S_z = 5727,5 \text{ Nm} \cdot 1,4 \cdot 1 = 8019 \text{ Nm}$	acc. to equation 3)

## Verifying the dimensioning result

Value	System data	Coupling data TNR 320.1 Vk90
Nominal torque	4009 Nm (excl. safety factor)	8500 Nm
Maximum torque	8019 Nm (excl. safety factor)	17000 Nm
Speed	1480 rpm	max. 2500 rpm
Shaft diameter motor	95 mm	max. 120 mm
Shaft diameter pump	85 mm	max. 120 mm

## Arrangement of the coupling parts

The coupling hubs have to be arranged on the shaft ends in accordance with the coupling type. In order to obtain a shaft-hub connection that is capable of carrying the load it is important to ensure that the hubs are pushed onto the shaft until the face of the hub is flush with the shaft end.

## Bore

The stated values for the finished bores are valid for a keyway according to DIN 6885/1 and must not be exceeded. To ensure true running, select the bore fit in such a manner that, when mating it with the shaft tolerance, a tight fit or light interference fit, such as e.g. H7/m6 or tighter, results. Precise details are required for shrinking a keyless hub on a shaft.

## Fastening on a shaft

If not specified RINGFEDER® couplings are usually supplied with keyways according to DIN 6885/1. In addition, the hub should be axially locked in position, for example by means of a set screw, or by means of distance rings in case of longer shaft ends. The key must be axially fixed in the shaft.

## Observe restoring forces

The coupling compensates the permissible misalignments with low restoring forces. Please observe the alignment values specified in the assembly and operation manual. If highly loaded bearings are involved, the additional loads resulting from the restoring forces should be taken into consideration. In such cases, please contact RINGFEDER POWER TRANSMISSION for more detailed information.

## Shaft end bearings

The shaft ends to be coupled should be supported by bearings which are directly fitted in front and after the coupling.

### Attention!

In the interest of further development, we reserve the right to make changes which serve technological progress. Carefully observe the actually instructions given in the relevant installation and operation manual, which can be downloaded from our webpage [www.ringfeder.com](http://www.ringfeder.com).



# Technical data sheet

Size	Buffer inside/outside	Nominal torque	Max. torque	Permanent oscillating torque <sup>*)</sup>	Max. speed	Dynamical stiffness ( $C_{t_{dyn}}$ )			
		$T_{KN}$ Nm	$T_{Kmax}$ Nm	$T_{KW}$ Nm	$n_{max}$ 1/min	0,25 $T_{KN}$ kNm/rad	0,5 $T_{KN}$ kNm/rad	0,75 $T_{KN}$ kNm/rad	1 $T_{KN}$ kNm/rad
120.1	Pb 60	160	320	96	6000	1,4	1,8	2,1	2,3
160.2	Pb 60 / Pb 60				5000	0,9	1,2	1,4	1,6
120.1	Pb 70	180	360	108	6000	2,2	2,8	3,3	3,8
160.2	Pb 70 / Pb 60				5000	1,3	1,6	1,8	2,1
120.1	Pb 80	300	600	180	6000	2,6	3,1	3,5	3,9
160.2	Pb 80 / Pb 70				5000	1,6	2,0	2,3	2,6
120.1	VK 80	300	600	180	6000	3,9	4,7	5,5	6,1
160.2	VK 80 / Vk 80				5000	2,6	3,2	3,6	4,1
120.1	VK 90	510	1020	306	6000	9,0	11,0	12,8	14,3
160.2	VK 90 / Vk 80				5000	4,2	5,1	5,9	6,6
160.1	Pb 60	325	650	195	5000	2,8	3,5	4,1	4,7
200.2	Pb 60 / Pb 60				4000	1,9	2,4	2,8	3,1
160.1	Pb 70	360	720	216	5000	4,5	5,7	6,7	7,5
200.2	Pb 70 / Pb 60				4000	2,5	3,2	3,7	4,2
160.1	Pb 80	600	1200	360	5000	5,2	6,2	7,1	7,8
200.2	Pb 80 / Pb 70				4000	3,3	4,1	4,7	5,2
160.1	VK 80	600	1200	360	5000	7,8	9,5	10,9	12,2
200.2	VK 80 / Vk 80				4000	5,2	6,4	7,4	8,3
160.1	VK 90	1020	2040	612	5000	17,9	22,1	25,6	28,6
200.2	VK 90 / Vk 90				4000	8,5	10,4	12,1	13,5
200.1	Pb 60	675	1350	405	4000	6,0	7,5	8,7	9,8
260.2	Pb 60 / Pb 60				3600	3,9	4,9	5,7	6,5
200.1	Pb 70	750	1500	450	4000	9,3	11,8	13,9	15,6
260.2	Pb 70 / Pb 60				3600	5,2	6,6	7,7	8,7
200.1	Pb 80	1250	2500	750	4000	10,9	13,0	14,7	16,3
260.2	Pb 80 / Pb 70				3600	6,9	8,4	9,6	10,7
200.1	VK 80	1250	2500	750	4000	16,2	19,8	22,8	25,5
260.2	VK 80 / Vk 80				3600	10,8	13,2	15,2	17,0
200.1	VK 90	2125	4250	1275	4000	37,4	46,0	53,3	59,7
260.2	VK 90 / Vk 80				3600	17,3	21,3	24,6	27,5
260.1	Pb 60	1350	2700	810	3600	11,8	14,8	17,2	19,4
320.2	Pb 60 / Pb 60				3000	7,9	9,8	11,4	12,9
260.1	Pb 70	1500	3000	900	3600	18,7	23,6	27,7	31,3
320.2	Pb 70 / Pb 60				3000	10,4	13,1	15,3	17,3
260.1	Pb 80	2500	5000	1500	3600	21,8	25,9	29,5	32,6
320.2	Pb 80 / Pb 70				3000	13,7	16,7	19,2	21,4
260.1	VK 80	2500	5000	1500	3600	32,3	39,5	45,6	51,0
320.2	VK 80 / Vk 80				3000	21,6	26,4	30,4	34,0
260.1	VK 90	4250	8500	2550	3600	74,7	92,0	106,6	119,3
320.2	VK 90 / Vk 80				3000	34,7	42,5	49,1	55,0

To continue see next page



Size	Buffer inside/outside	Nominal torque	Max. torque	Permanent oscillating torque <sup>*)</sup>	Max. speed	Dynamical stiffness (Ct <sub>dyn</sub> )			
		T <sub>KN</sub>	T <sub>Kmax</sub>	T <sub>KW</sub>	n <sub>max</sub>	0,25 T <sub>KN</sub>	0,5 T <sub>KN</sub>	0,75 T <sub>KN</sub>	1 T <sub>KN</sub>
		Nm	Nm	Nm	1/min	kNm/rad	kNm/rad	kNm/rad	kNm/rad
320.1	Pb 60	2700	5400	1620	3000	23,6	29,5	34,3	38,8
400.2	Pb 60 / Pb 60				2400	15,7	19,7	22,9	25,8
320.1	Pb 70	3000	6000	1800	3000	37,3	47,3	55,4	62,5
400.2	Pb 70 / Pb 60				2400	20,8	26,2	30,7	34,6
320.1	Pb 80	5000	10000	3000	3000	43,5	51,8	58,9	65,3
400.2	Pb 80 / Pb 70				2400	27,5	33,5	38,5	42,9
320.1	VK 80	5000	10000	3000	3000	64,7	79,1	91,2	101,9
400.2	VK 80 / Vk 80				2400	43,1	52,7	60,8	67,9
320.1	VK 90	8500	17000	5100	3000	149,4	184,1	213,2	238,7
400.2	VK 90 / Vk 80				2400	69,3	85,1	98,3	109,9
400.1	Pb 60	5400	10800	3240	2400	47,8	59,7	69,5	78,5
500.2	Pb 60 / Pb 60				1800	31,4	39,3	45,8	51,7
400.1	Pb 70	6000	12000	3600	2400	74,7	94,5	110,8	125,0
500.2	Pb 70 / Pb 60				1800	41,7	52,5	61,3	69,2
400.1	Pb 80	10000	20000	6000	2400	87,0	103,7	117,8	130,5
500.2	Pb 80 / Pb 70				1800	55,0	66,9	76,9	85,7
400.1	VK 80	10000	20000	6000	2400	129,3	158,2	182,3	203,8
500.2	VK 80 / Vk 80				1800	86,2	105,4	121,6	135,9
400.1	VK 90	17000	34000	10200	2400	298,8	368,2	426,3	477,3
500.2	VK 90 / Vk 80				1800	138,6	170,1	196,5	219,9
500.1	Pb 60	10800	21600	6480	1800	94,3	118,0	137,3	155,0
640.2	Pb 60 / Pb 60				1500	62,9	78,7	91,6	103,3
500.1	Pb 70	12000	24000	7200	1800	149,3	189,0	221,7	250,0
640.2	Pb 70 / Pb 60				1500	83,4	105,0	122,7	138,4
500.1	Pb 80	20000	40000	12000	1800	174,0	207,3	235,7	261,0
640.2	Pb 80 / Pb 70				1500	109,9	133,9	153,9	171,5
500.1	VK 80	20000	40000	12000	1800	258,7	316,3	364,7	407,7
640.2	VK 80 / Vk 80				1500	172,4	210,9	243,1	271,8
500.1	VK 90	34000	68000	20400	1800	597,6	736,3	852,7	954,7
640.2	VK 90 / Vk 80				1500	277,3	340,3	393,1	439,8
640.1	Pb 60	21600	43200	12960	1500	188,7	236,0	274,7	310,0
640.1	Pb 70	24000	48000	14400	1500	298,7	378,0	443,3	500,0
640.1	Pb 80	40000	80000	24000	1500	348,0	414,7	471,3	522,0
640.1	VK 80	40000	80000	24000	1500	517,3	632,7	729,3	815,3
640.1	VK 90	68000	136000	40800	1500	1195,2	1472,7	1705,3	1909,3

<sup>\*)</sup> Permanent oscillating torque  $\pm T_{KW}$  at  $f \geq 10$  Hz, applies at higher frequencies  $f_x$  gilt  $T_{KW} \cdot \sqrt{\frac{10}{f_x}}$

The data shown are an extract and apply to preferred buffer material combinations. Especially data for material combinations for low and high temperature applications are available on request. The characteristics of elastic materials depend on ambient temperature, frequency of the excitation and load change sequence,

also manufacturing tolerances. These physical characteristics underlie the given stiffness data of the TNR buffers and should be considered when interpreting the calculated torsional harmonics (TVA). Further information on request.



# Ordering examples

■ **RINGFEDER® TNR 2424.1, size 260.1 – 16 Pb 70/100 H7/keyway to DIN 6885/1 P9/set screw**

Torsional highflex RINGFEDER® TNR 2424.1, single-row, size 260, Pb 70 buffer and SAE flange connection size 16, hub bore diameter 100 H7 with keyway to DIN 6885/1 tolerance P9 and set screw

■ **RINGFEDER® TNR 2424.2, size 260.2 – 16 Pb 70/ Pb 60/80 H7/keyway to DIN 6885/1 P9/set screw**

Torsional highflex RINGFEDER® TNR 2424.1, double-row, size 260, Pb 70 buffer inside and Pb 60 outside and SAE flange connection size 16, hub bore diameter 80 H7 with keyway to DIN 6885/1 tolerance P9 and set screw

■ **RINGFEDER® TNR 2425.2, size 260.2 – 11.5 Vk 90/ Vk 80/2517/48**

Torsional highflex RINGFEDER® TNR 2425.2, double-row, size 260, Vk 90 buffer inside and Vk 80 outside and SAE flange connection size 11.5, with taper lock bushing 2517 bush arbor hole 48

■ **RINGFEDER® TNR 2428.1, size 260.1 Vk 90/100 H7/ keyway to DIN 6885/1 P9/set screw /120 H7/keyway to DIN 6885/1 P9/set screw**

Torsional highflex RINGFEDER® TNR 2428.1, single-row, size 260, Vk 90 buffer, hub bore diameter 100 H7 with keyway to DIN 6885/1 tolerance P9 and set screw flange hub bore diameter 120 H7 with keyway to DIN 6885/1 tolerance P9 and set screw

■ **RINGFEDER® TNR 2428.2, size 260.2 Vk 90/Vk 80/100 H7/keyway to DIN 6885/1 P9/ set screw /120 H7/keyway to DIN 6885/1 P9/set screw**

Torsional highflex RINGFEDER® TNR 2428.2, double-row, size 260, Vk 90 buffer inside, Vk 80 outside hub bore diameter 100 H7 with keyway to DIN 6885/1 tolerance P9 and set screw flange hub bore diameter 120 H7 with keyway to DIN 6885/1 tolerance P9 and set screw



## Excerpt delivery program taper bushings

Bore	Keyway width	Identifier					
		1615	2012	2517	3535	4040	5050
19	6	x	x	x			
24	8	x	x	x			
28	8	x	x	x	x		
30	8	x	x	x	x		
32	10	x	x	x	x		
38	10	x	x	x	x		
40	12	x	x	x	x	x	
42	12	x	x	x	x	x	
48	14		x	x	x	x	
50	14		x	x	x	x	
55	16			x	x	x	
60	18			x	x	x	
65	18			x	x	x	
70	20				x	x	x
75	20				x	x	x
80	22				x	x	x
85	22				x	x	x
90	25				x	x	x
95	25				x	x	x
100	28					x	x
105	28						x
110	28						x
115	32						x
120	32						x
125	32						x



# Solution for limited axial installation space

If axial space is extremely restricted, as demanded under DIN 6281, the free space in the flywheel may be utilised using a cropped SAE flange.

## Prevention of disconnection

Disconnection may on request be prevented if it is necessary to ensure emergency operation of the couplings. This will maintain synchronism of the components. Disconnection prevention may be retrofitted for all coupling types.

The RINGFEDER® TNR coupling will disconnect on failing (non fail-safe). This means that the drive train will disconnect should the elastic buffers be destroyed.

The RINGFEDER® TNR may be fitted to prevent disconnecting in applications where emergency operation must be enabled or a load must be supported.

Metal claws which do not make contact under permissible loads will in this event transfer the torque.

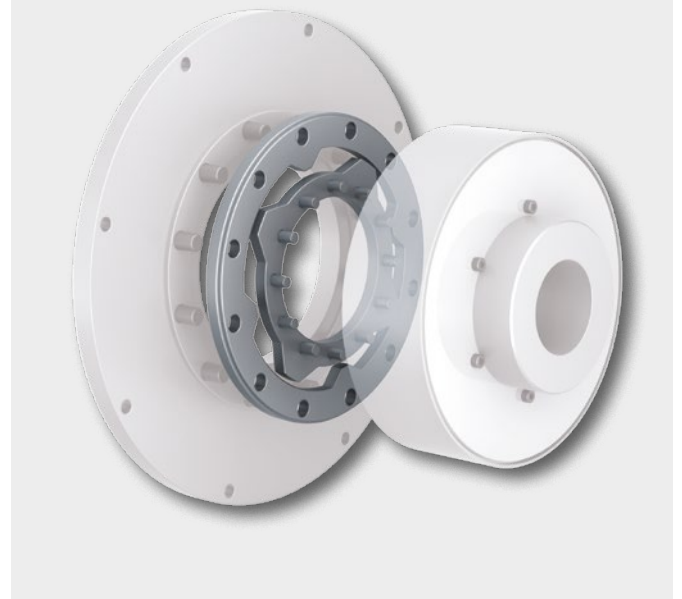
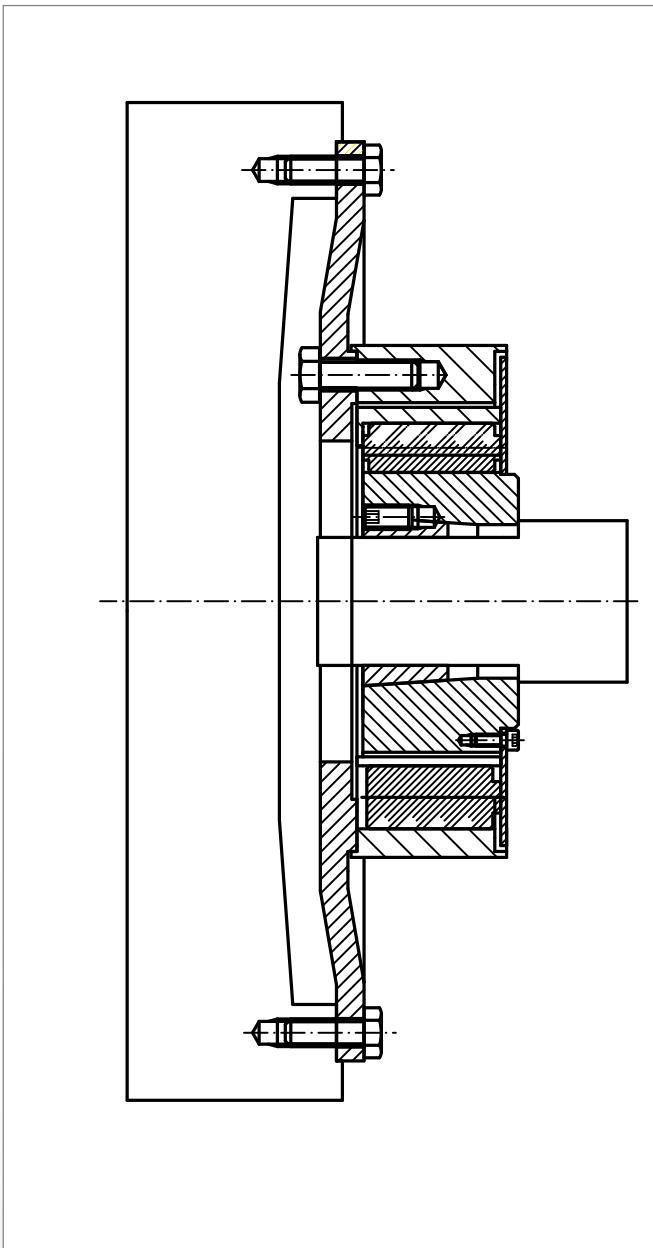

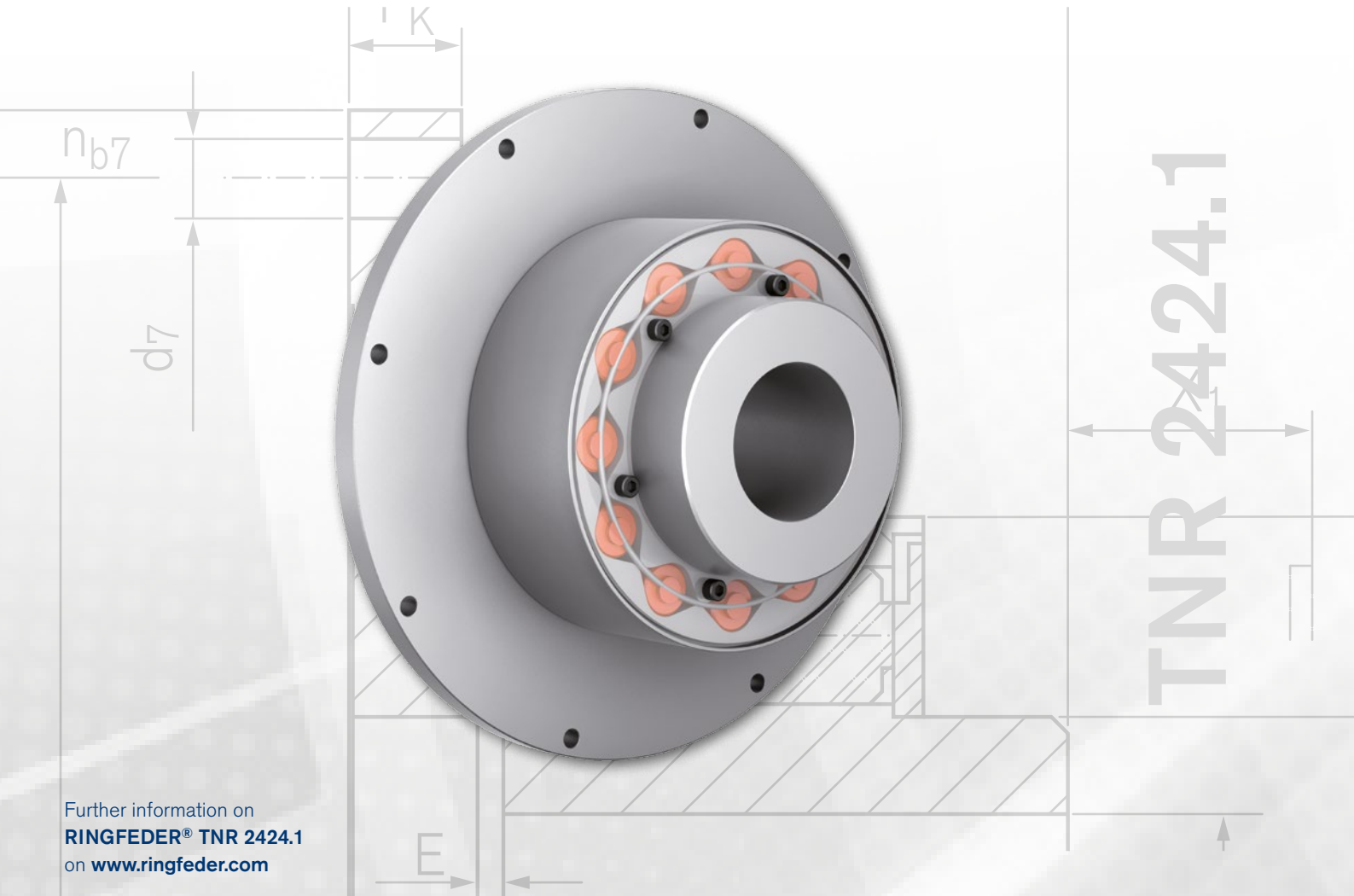

Further information on  
**RINGFEDER® TNR 2424.1**  
on [www.ringfeder.com](http://www.ringfeder.com)

## Single-row, SAE flange-shaft connections

Single-row torsional highflex **RINGFEDER® TNR 2424.1** for flange-shaft connection, flange connecting dimensions acc. to SAE J 620 d. In mind of X1 easy replacement of the elastic elements without axial movement of the coupled machines.

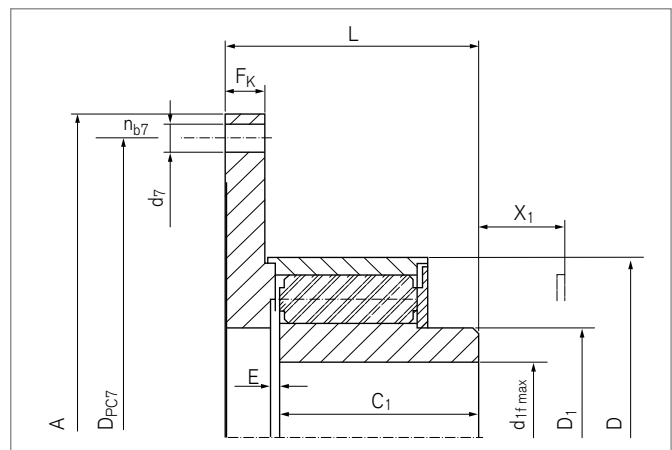

### Properties

- Specific adjustment of dynamic characteristics by selection of the elastic buffers
- Can be executed as puncture-proof using simple modification
- Very compact construction, allowing the coupling to be installed in confined spaces
- Easy exchange of wearing parts without dismantling hubs or flanges
- The modular system design allows special solutions to be cost-effectively implemented
- Adjustment of the stiffness at no additional cost, even for single projects

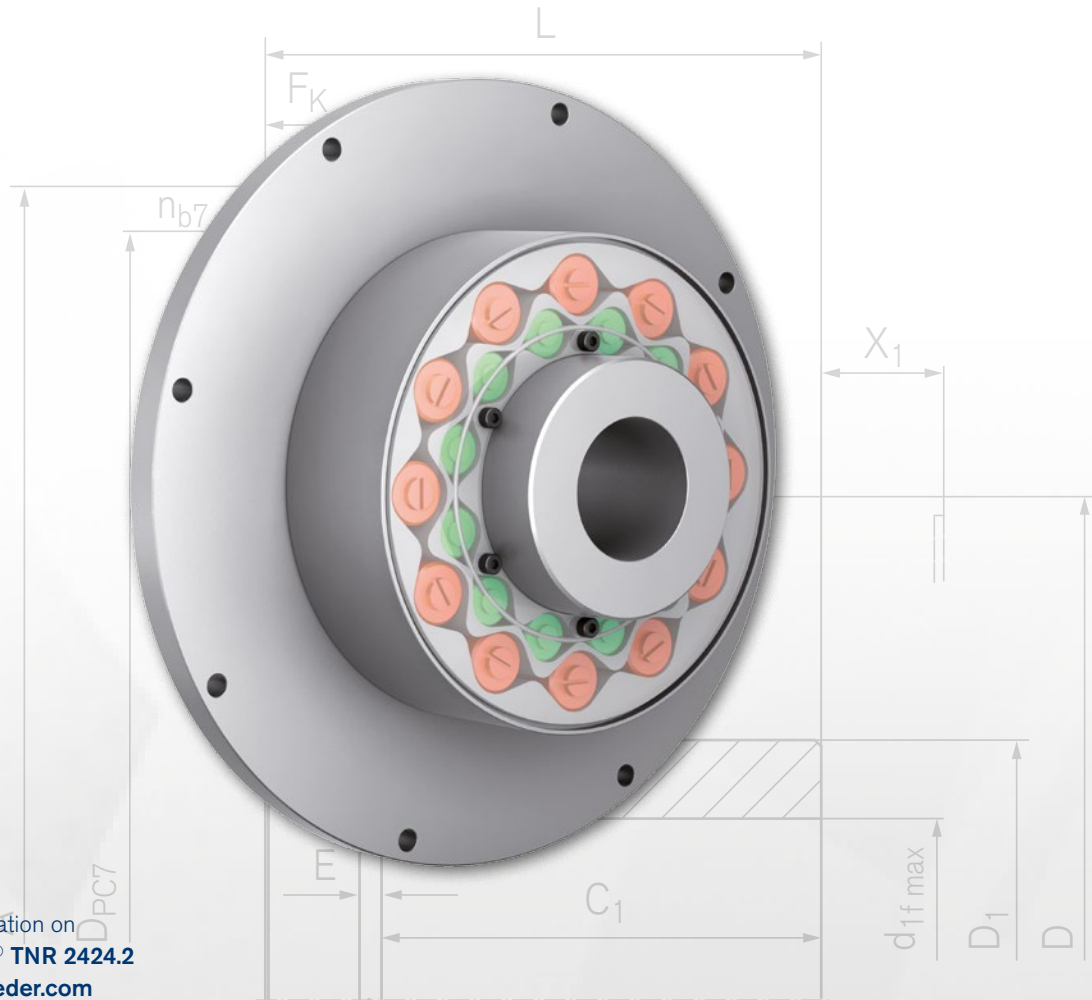

Further information on  
**RINGFEDER® TNR 2424.2**  
 on [www.ringfeder.com](http://www.ringfeder.com)

## Double-row, SAE flange-shaft connections

Double-row torsional highflex **RINGFEDER® TNR 2424.2** for flange-shaft connection, flange connecting dimensions acc. to SAE J 620 d. In mind of X1 easy replacement of the elastic buffers without axial movement of the coupled machines.

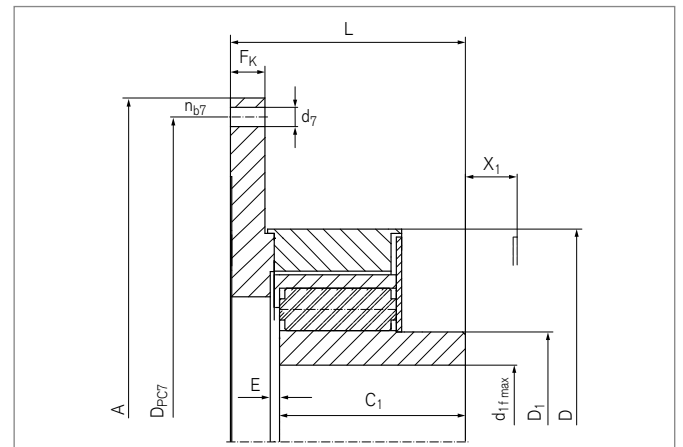

### Properties

- Specific adjustment of dynamic characteristics by selection of the elastic buffers
- Can be executed as puncture-proof using simple modification
- Very compact construction, allowing the coupling to be installed in confined spaces
- Easy exchange of wearing parts without dismantling hubs or flanges
- The modular system design allows special solutions to be cost-effectively implemented
- Adjustment of the stiffness at no additional cost, even for single projects

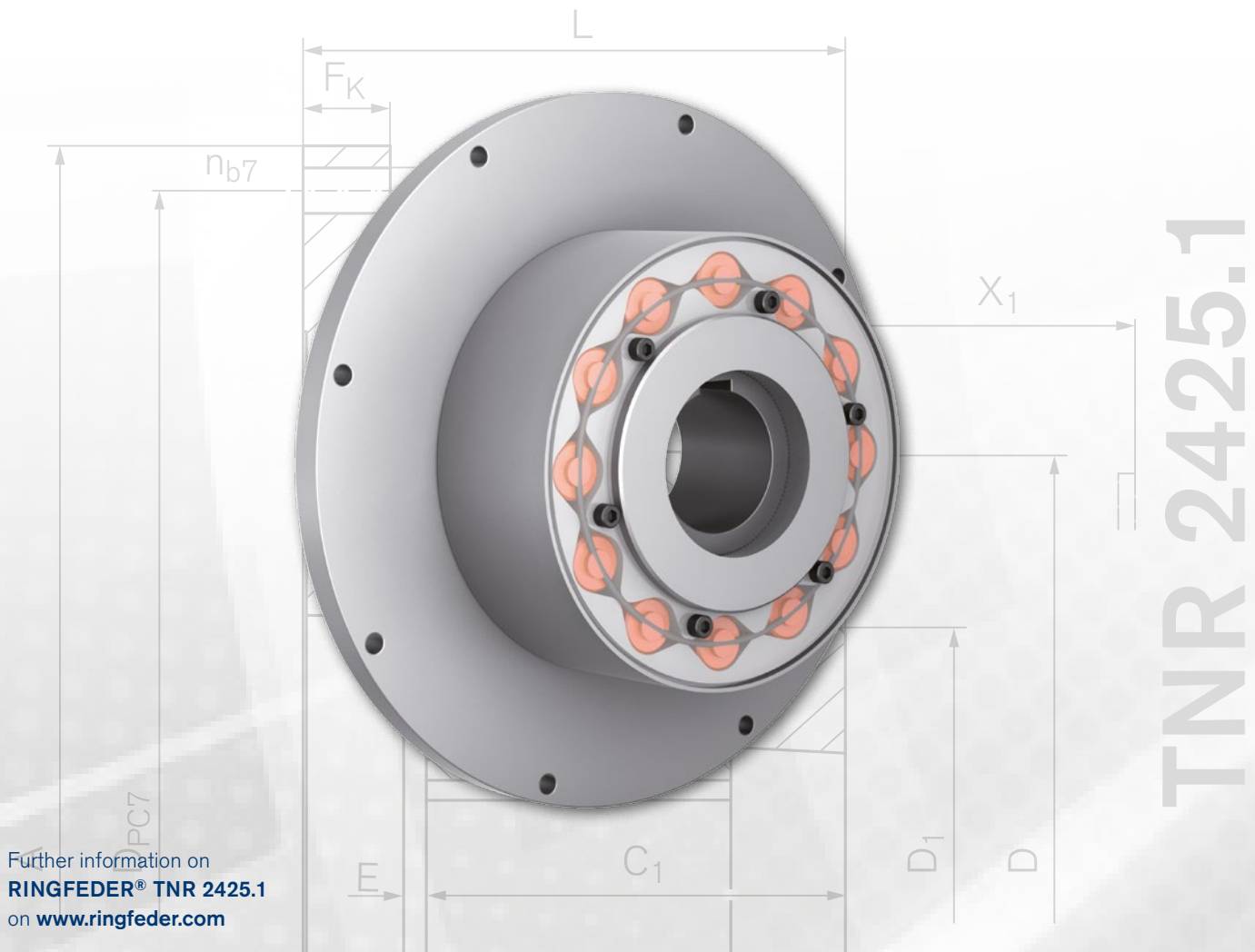

TNR 2425.1

Further information on  
**RINGFEDER® TNR 2425.1**  
 on [www.ringfeder.com](http://www.ringfeder.com)

## Single-row, SAE flange-shaft connections with taper clamping bush

Single-row torsional highflex **RINGFEDER® TNR 2425.1** for flange-shaft connection and taper lock bushing systems, flange dimensions acc. to SAE J 620 d. In mind of X<sub>1</sub> easy replacement of the elastic elements without axial movement of the coupled machines.

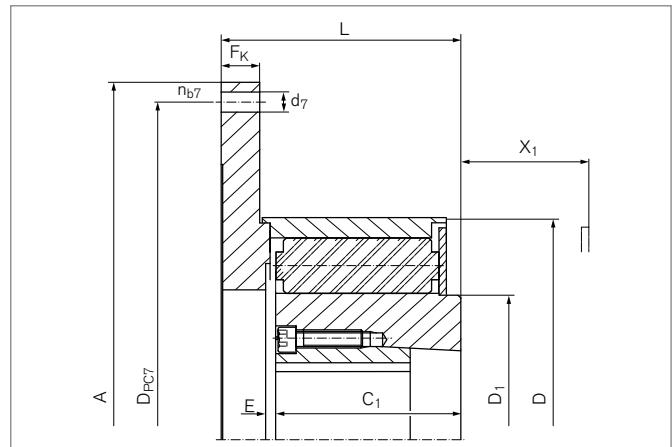

### Properties

- Specific adjustment of dynamic characteristics by selection of the elastic buffers
- Can be executed as puncture-proof using simple modification
- Very compact construction, allowing the coupling to be installed in confined spaces
- Easy exchange of wearing parts without dismantling hubs or flanges
- The modular system design allows special solutions to be cost-effectively implemented
- Adjustment of the stiffness at no additional cost, even for single projects

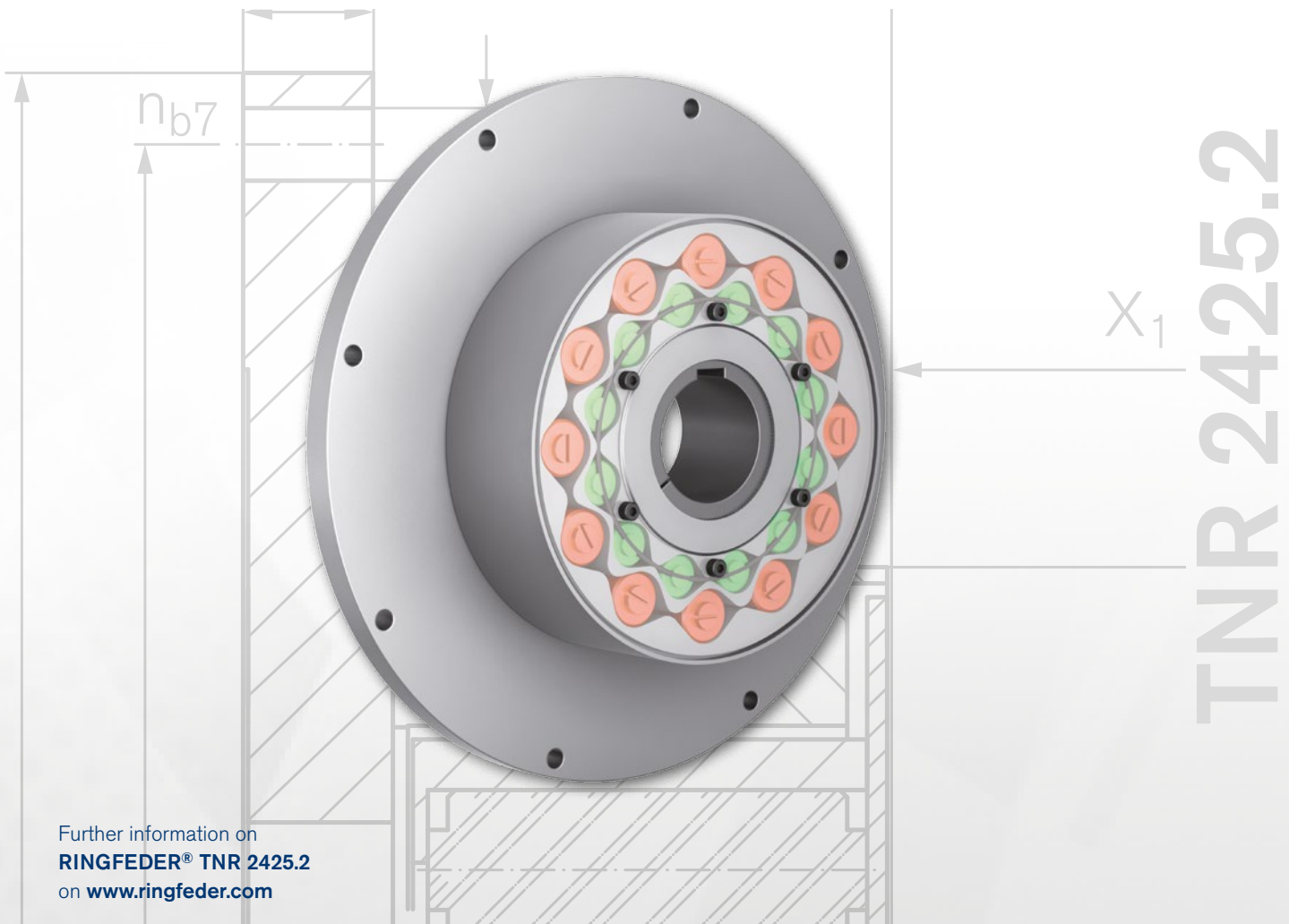

TNR 2425.2

Further information on  
**RINGFEDER® TNR 2425.2**  
 on [www.ringfeder.com](http://www.ringfeder.com)

## Double-row, SAE flange-shaft connections with taper clamping bush

Double-row torsional highflex **RINGFEDER® TNR 2425.2** for flange-shaft connection and taper lock bushing systems, flange dimensions acc. to SAE J 620 d. In mind of X1 easy replacement of the elastic elements without axial movement of the coupled machines.

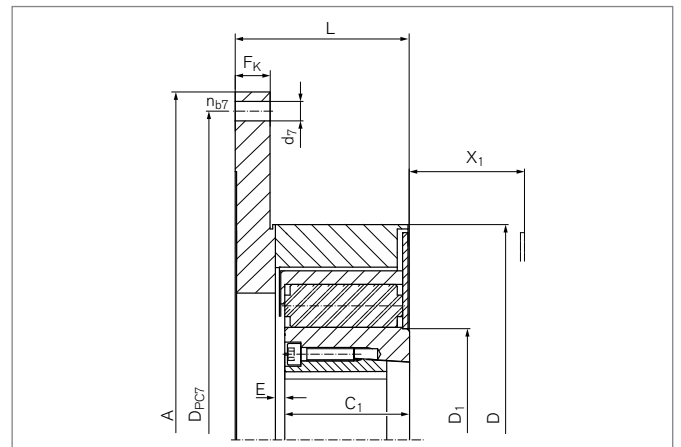

### Properties

- Specific adjustment of dynamic characteristics by selection of the elastic buffers
- Can be executed as puncture-proof using simple modification
- Very compact construction, allowing the coupling to be installed in confined spaces
- Easy exchange of wearing parts without dismantling hubs or flanges
- The modular system design allows special solutions to be cost-effectively implemented
- Adjustment of the stiffness at no additional cost, even for single projects

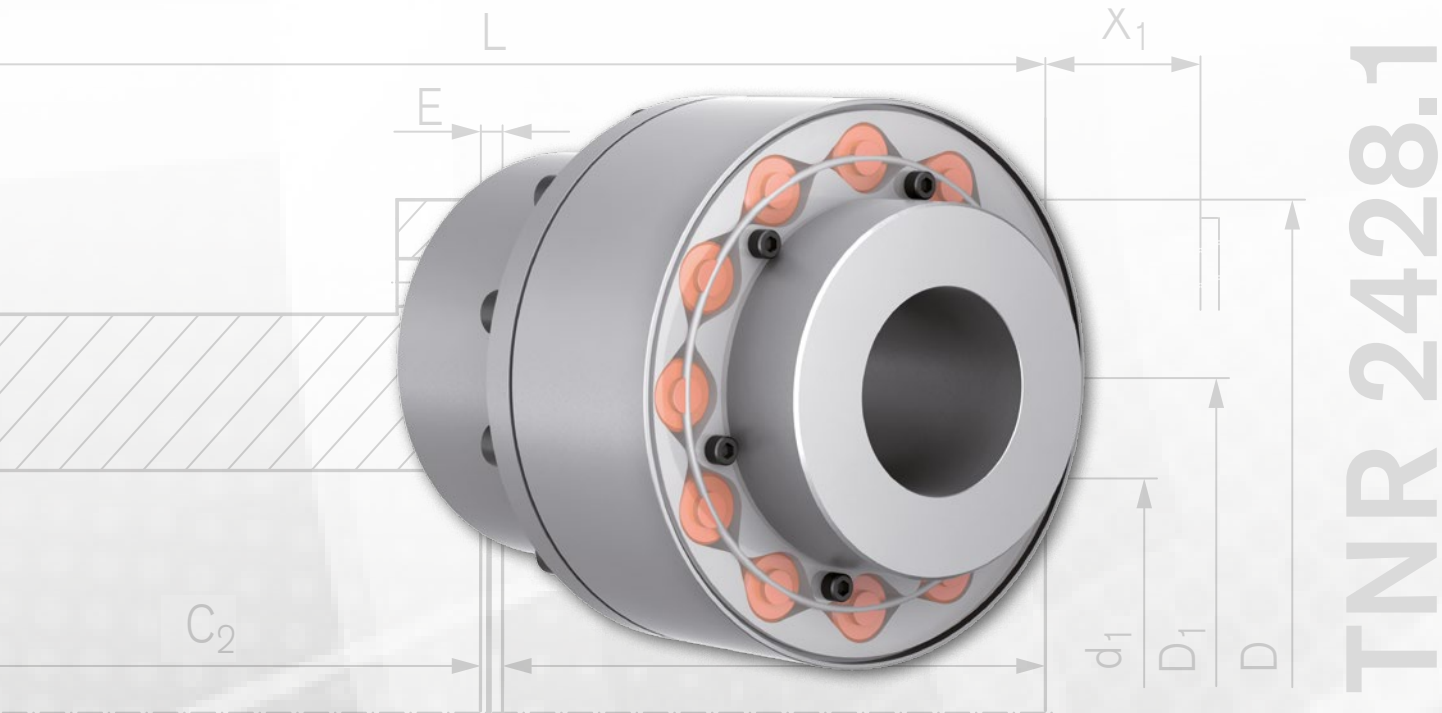

TNR 2428.1

Further information on  
**RINGFEDER® TNR 2428.1**  
 on [www.ringfeder.com](http://www.ringfeder.com)

## Single-row, shaft-shaft connections

Single-row torsional highflex **RINGFEDER® TNR 2428.1** for shaft-shaft connection. In mind of X1 easy replacement of the elastic elements without axial movement of the coupled machines.

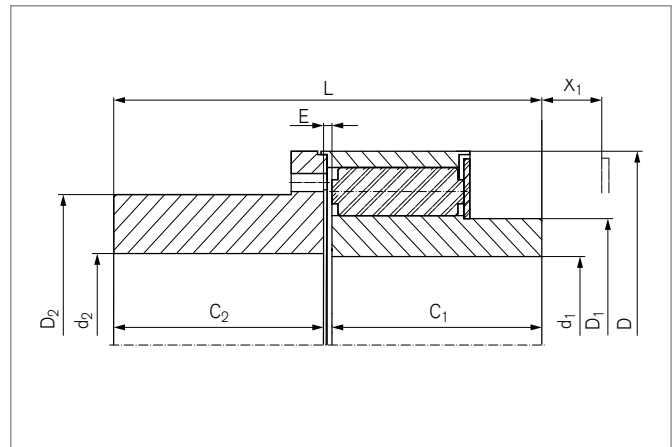

### Properties

- Specific adjustment of dynamic characteristics by selection of the elastic buffers
- Can be executed as puncture-proof using simple modification
- Very compact construction, allowing the coupling to be installed in confined spaces
- Easy exchange of wearing parts without dismantling hubs or flanges
- The modular system design allows special solutions to be cost-effectively implemented
- Adjustment of the stiffness at no additional cost, even for single projects

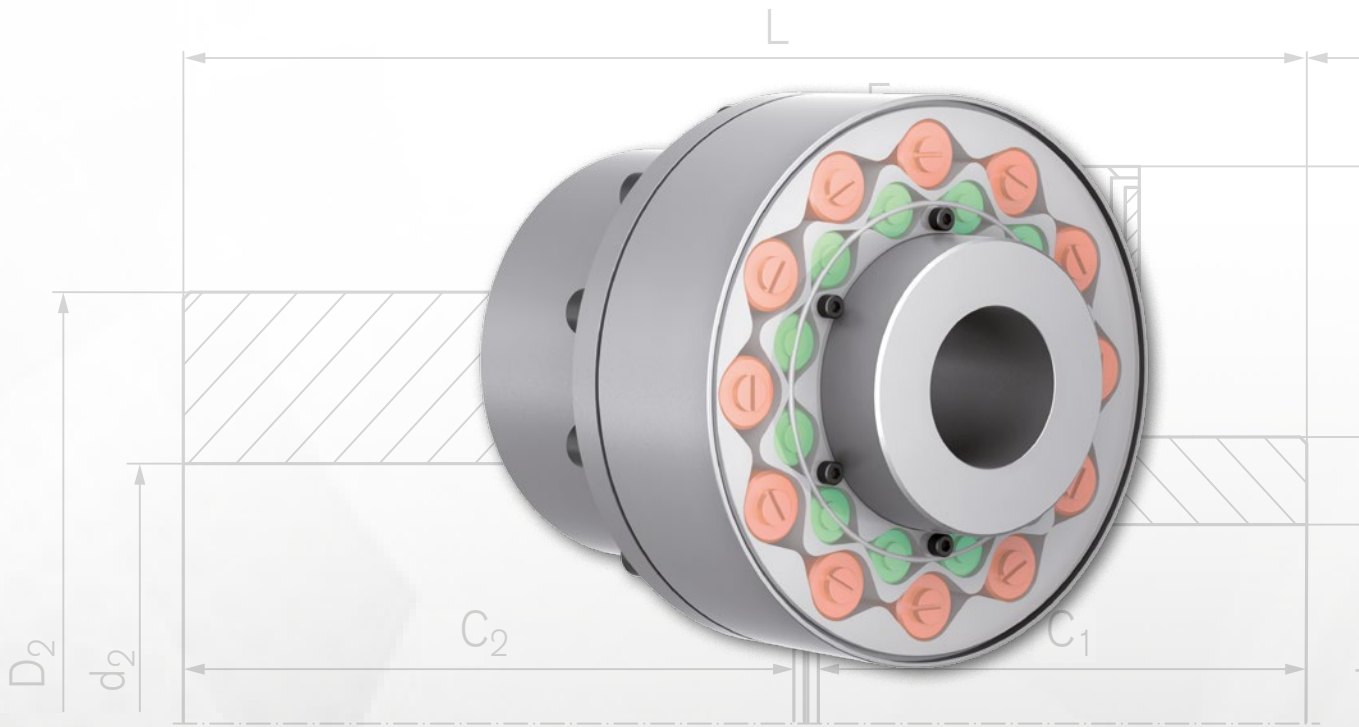

TNR 2428.2

Further information on  
**RINGFEDER® TNR 2428.2**  
 on [www.ringfeder.com](http://www.ringfeder.com)

## Double-row, shaft-shaft connections

Double-row torsional highflex **RINGFEDER® TNR 2428.2** for shaft-shaft connection. In mind of  $X_1$  easy replacement of the elastic buffers without axial movement of the coupled machines.

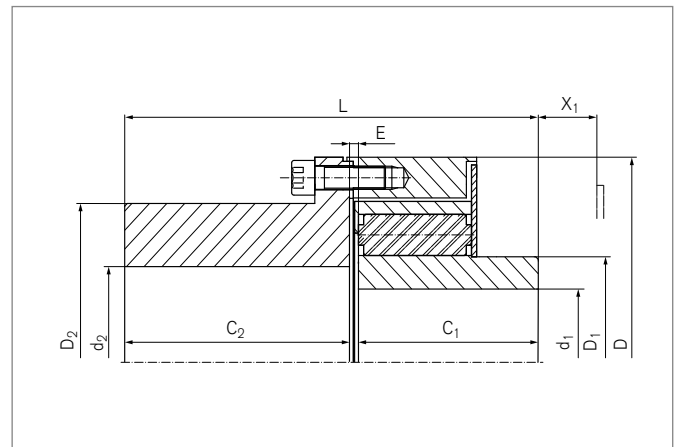

### Properties

- Specific adjustment of dynamic characteristics by selection of the elastic buffers
- Can be executed as puncture-proof using simple modification
- Very compact construction, allowing the coupling to be installed in confined spaces
- Easy exchange of wearing parts without dismantling hubs or flanges
- The modular system design allows special solutions to be cost-effectively implemented
- Adjustment of the stiffness at no additional cost, even for single projects







# Torsional Highflex Couplings **RINGFEDER® TNR**

## Tables & Values

The equations and recommendations from the chapter 'Dimensioning of coupling' must be taken into account in order to determine coupling size.



# Torsional Highflex Couplings

## RINGFEDER® TNR 2424.1

### Single-row, SAE flange-shaft connections

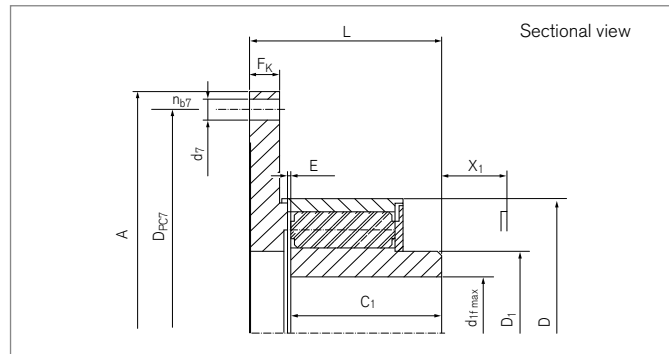

Size	$d_{1f \max}$	SAE size	A	$D_{pc7}$	$d_7$	$n_{b7}$	D	$D_1$	$C_1$
			mm	mm	mm		mm	mm	mm
120.1 - 06.5	50	6,5	215,9	200,0	9,5	6	120	73	65
120.1 - 07.5	50	7,5	241,3	222,3	9,5	8	120	73	65
120.1 - 08.0	50	8,0	263,5	244,5	11,0	6	120	73	65
120.1 - 10.0	50	10,0	314,3	295,3	11,0	8	120	73	65
160.1 - 06.5	70	6,5	215,9	200,0	9,5	6	160	100	90
160.1 - 07.5	70	7,5	241,3	222,3	9,5	8	160	100	90
160.1 - 08.0	70	8,0	263,5	244,5	11,0	6	160	100	90
160.1 - 10.0	70	10,0	314,3	295,3	11,0	8	160	100	90
200.1 - 07.5	90	7,5	241,3	222,3	9,5	8	200	129	115
200.1 - 08.0	90	8,0	263,5	244,5	11,0	6	200	129	115
200.1 - 10.0	90	10,0	314,3	295,3	11,0	8	200	129	115
200.1 - 11.5	90	11,5	352,4	333,7	11,0	8	200	129	115
260.1 - 10.0	115	10,0	314,3	295,3	11,0	8	260	165	140
260.1 - 11.5	115	11,5	352,4	333,7	11,0	8	260	165	140
260.1 - 14.0	115	14,0	466,7	438,2	14,5	8	260	165	140
260.1 - 16.0	115	16,0	517,5	489,0	14,5	8	260	165	140
320.1 - 14.0	145	14,0	466,7	438,2	14,5	8	320	210	175
320.1 - 16.0	145	16,0	517,5	489,0	14,5	8	320	210	175
320.1 - 18.0	145	18,0	571,5	542,9	18,0	6	320	210	175
400.1 - 16.0	185	16,0	517,5	489,0	14,5	8	400	275	230
400.1 - 18.0	185	18,0	571,5	542,9	18,0	6	400	275	230
400.1 - 21.0	185	21,0	673,1	641,4	18,0	12	400	275	230
400.1 - 24.0	185	24,0	733,4	692,2	22,0	12	400	275	230
500.1 - 21.0	230	21,0	673,1	641,4	18,0	12	500	335	300
500.1 - 24.0	230	24,0	733,4	692,2	22,0	12	500	335	300

To continue see next page

**Torsional Highflex Couplings RINGFEDER® TNR 2424.1**

Size	L	E	F <sub>E</sub>	F <sub>K</sub>	X <sub>1</sub>	J <sub>F</sub>	J <sub>N</sub> <sup>1)</sup>	Gw <sub>ub</sub> <sup>1)</sup>
	mm	mm	mm	mm	mm	10 <sup>-3</sup> kgm <sup>2</sup>	10 <sup>-3</sup> kgm <sup>2</sup>	kg
120.1 - 06.5	84	4,0	+/-1,0	13	28	6	2	4,1
120.1 - 07.5	84	4,0	+/-1,0	13	28	9	2	4,4
120.1 - 08.0	84	4,0	+/-1,0	13	28	12	2	4,7
120.1 - 10.0	84	4,0	+/-1,0	13	28	26	2	5,4
160.1 - 06.5	111	4,0	+/-1,0	15	23	9	11	8,6
160.1 - 07.5	111	4,0	+/-1,0	15	23	12	11	8,9
160.1 - 08.0	111	4,0	+/-1,0	15	23	16	11	9,2
160.1 - 10.0	111	4,0	+/-1,0	15	23	31	11	10,1
200.1 - 07.5	140	5,0	+/-1,5	18	28	23	35	16,9
200.1 - 08.0	140	5,0	+/-1,5	18	28	28	35	17,3
200.1 - 10.0	140	5,0	+/-1,5	18	28	45	35	18,4
200.1 - 11.5	140	5,0	+/-1,5	18	28	66	35	19,3
260.1 - 10.0	172	6,0	+/-1,5	24	40	92	116	35,0
260.1 - 11.5	172	6,0	+/-1,5	24	40	118	116	36,3
260.1 - 14.0	172	6,0	+/-1,5	24	40	260	116	40,4
260.1 - 16.0	172	6,0	+/-1,5	24	40	381	116	42,8
320.1 - 14.0	212	7,0	+/-2,0	26	45	474	375	73,5
320.1 - 16.0	212	7,0	+/-2,0	26	45	662	375	76,6
320.1 - 18.0	212	7,0	+/-2,0	26	45	1195	375	83,0
400.1 - 16.0	271	8,0	+/-2,0	31	46	760	1274	142,0
400.1 - 18.0	271	8,0	+/-2,0	31	46	971	1274	146,0
400.1 - 21.0	271	8,0	+/-2,0	31	46	1579	1274	153,0
400.1 - 24.0	271	8,0	+/-2,0	31	46	2035	1274	158,0
500.1 - 21.0	346	10,0	+/-2,5	34	52	2402	4155	289,0
500.1 - 24.0	346	10,0	+/-2,5	34	52	2877	4155	294,0

<sup>1)</sup> Weight and moment of inertia for unbored hubs

To continue see next page

## Torsional Highflex Couplings RINGFEDER® TNR 2424.1

### Explanations

<b>d<sub>1f max</sub></b> = Max. bore diameter d <sub>1</sub> with keyway acc. to ANSI B17.1	<b>D</b> = Outer diameter	<b>F<sub>K</sub></b> = Flange thickness
<b>SAE</b> = Flange connection to SAE J 620 d	<b>D<sub>1</sub></b> = Outer diameter	<b>X<sub>1</sub></b> = Required space for dismounting of the elastic buffer
<b>A</b> = Max. outer diameter	<b>C<sub>1</sub></b> = Guided length in hub bore	<b>J<sub>F</sub></b> = Moment of inertia on thrust flange side
<b>D<sub>PC7</sub></b> = Pitch circle diameter of bore holes d <sub>7</sub>	<b>L</b> = Total length	<b>J<sub>N</sub></b> = Moment of inertia hub side
<b>d<sub>7</sub></b> = Bore diameter	<b>E</b> = Gap width between left and right component	<b>G<sub>wub</sub></b> = Weight, unbored
<b>n<sub>b7</sub></b> = Quantity of bore d <sub>7</sub>	<b>F<sub>E</sub></b> = Tolerance of the gap width E	

### Ordering example

Series	Size	Buffer	d <sub>1f</sub>	Further details <sup>1)</sup>
TNR 2424.1	200.1 - 08.0	Pb 70	80	*

<sup>1)</sup> Without any other specification, we deliver as a standard: with set screws and keyway acc. to DIN 6885-1, keyway side fit P9, bore tolerance H7

Further information on  
**RINGFEDER® TNR 2424.1**  
 on [www.ringfeder.com](http://www.ringfeder.com)

#### Disclaimer of liability

All technical details and notes are non-binding and cannot be used as a basis for legal claims. The user is obligated to determine whether the represented products meet his requirements. We reserve the right carry out modifications at any time in the interests of technical progress.

# Torsional Highflex Couplings

## RINGFEDER® TNR 2424.2

### Two-row, SAE flange-shaft connections

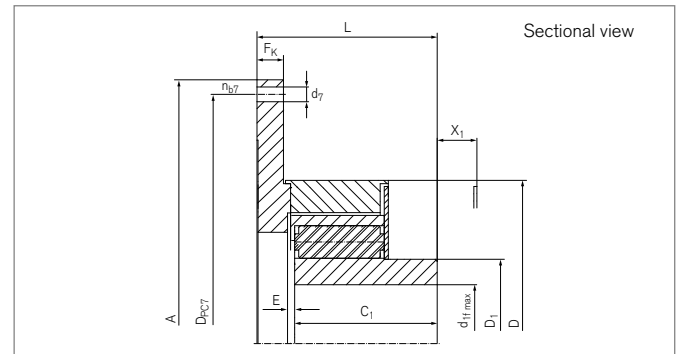

Size	$d_{1f \max}$	SAE size	A	$D_{PC7}$	$d_7$	$n_{b7}$	D	$D_1$	$C_1$
			mm	mm	mm		mm	mm	mm
160.2 - 06.5	50	6,5	215,9	200,0	9,5	6	160	73	65
160.2 - 07.5	50	7,5	241,3	222,3	9,5	8	160	73	65
160.2 - 08.0	50	8,0	263,5	244,5	11,0	6	160	73	65
160.2 - 10.0	50	10,0	314,3	295,3	11,0	8	160	73	65
200.2 - 07.5	70	7,5	222,3	213,3	9,5	8	200	100	90
200.2 - 08.0	70	8,0	263,5	244,5	11,0	6	200	100	90
200.2 - 10.0	70	10,0	314,3	295,3	11,0	8	200	100	90
200.2 - 11.5	70	11,5	352,4	333,7	11,0	8	200	100	90
260.2 - 10.0	90	10,0	314,3	295,3	11,0	8	260	129	115
260.2 - 11.5	90	11,5	352,4	333,7	11,0	8	260	129	115
260.2 - 14.0	90	14,0	466,7	438,2	14,5	8	260	129	115
260.2 - 16.0	90	16,0	517,5	489,0	14,5	8	260	129	115
320.2 - 14.0	115	14,0	466,7	438,2	14,5	8	320	165	140
320.2 - 16.0	115	16,0	517,5	489,0	14,5	8	320	165	140
320.2 - 18.0	115	18,0	571,5	542,9	18,0	6	320	165	140
400.2 - 16.0	145	16,0	517,5	489,0	14,5	8	400	208	175
400.2 - 18.0	145	18,0	571,5	542,9	18,0	6	400	208	175
400.2 - 21.0	145	21,0	673,1	641,4	18,0	12	400	208	175
400.2 - 24.0	145	24,0	733,4	692,2	22,0	12	400	208	175
500.2 - 21.0	185	21,0	673,1	641,4	18,0	12	500	268	230
500.2 - 24.0	185	24,0	733,4	692,2	22,0	12	500	268	230
640.2 - 24.0	230	24,0	733,4	692,2	22,0	12	640	335	300

To continue see next page

## Torsional Highflex Couplings RINGFEDER® TNR 2424.2

Size	L	E	F <sub>E</sub>	F <sub>K</sub>	X <sub>1</sub>	J <sub>F</sub>	J <sub>N</sub> <sup>1)</sup>	G <sub>Wub</sub> <sup>1)</sup>
	mm	mm	mm	mm	mm	10 <sup>-3</sup> kgm <sup>2</sup>	10 <sup>-3</sup> kgm <sup>2</sup>	kg
160.2 - 06.5	86	4,0	-1	15	28	10	3	5,0
160.2 - 07.5	86	4,0	-1	15	28	13	3	5,3
160.2 - 08.0	86	4,0	-1	15	28	17	3	5,6
160.2 - 10.0	86	4,0	-1	15	28	32	3	6,5
200.2 - 07.5	115	5,0	-2	18	23	21	14	10,1
200.2 - 08.0	115	5,0	-2	18	23	26	14	10,5
200.2 - 10.0	115	5,0	-2	18	23	43	14	11,6
200.2 - 11.5	115	5,0	-2	18	23	64	14	12,5
260.2 - 10.0	147	6,0	-2	24	28	86	44	21,9
260.2 - 11.5	147	6,0	-2	24	28	112	44	23,2
260.2 - 14.0	147	6,0	-2	24	28	254	44	27,3
260.2 - 16.0	147	6,0	-2	24	28	375	44	29,7
320.2 - 14.0	177	7,0	-2	26	39	464	144	47,4
320.2 - 16.0	177	7,0	-2	26	39	652	144	50,5
320.2 - 18.0	177	7,0	-2	26	39	1185	144	56,9
400.2 - 16.0	216	8,0	-2	31	51	740	462	83,4
400.2 - 18.0	216	8,0	-2	31	51	951	462	87,1
400.2 - 21.0	216	8,0	-2	31	51	1559	462	94,7
400.2 - 24.0	216	8,0	-2	31	51	2015	462	99,2
500.2 - 21.0	276	10,0	-3	34	52	2327	1544	172,0
500.2 - 24.0	276	10,0	-3	34	52	2802	1544	176,0
640.2 - 24.0	360	12,5	-5	45	60	5994	5100	340,0

<sup>1)</sup> Weight and moment of inertia for unbored hubs

To continue see next page

## Torsional Highflex Couplings RINGFEDER® TNR 2424.2

### Explanations

<b>d<sub>1f max</sub></b> = Max. bore diameter d <sub>1</sub> with keyway acc. to ANSI B17.1	<b>D</b> = Outer diameter	<b>F<sub>K</sub></b> = Flange thickness
<b>SAE</b> = Flange connection to SAE J 620 d	<b>D<sub>1</sub></b> = Outer diameter	<b>X<sub>1</sub></b> = Required space for dismounting of the elastic buffer
<b>A</b> = Max. outer diameter	<b>C<sub>1</sub></b> = Guided length in hub bore	<b>J<sub>F</sub></b> = Moment of inertia on thrust flange side
<b>D<sub>PC7</sub></b> = Pitch circle diameter of bore holes d <sub>7</sub>	<b>L</b> = Total length	<b>J<sub>N</sub></b> = Moment of inertia hub side
<b>d<sub>7</sub></b> = Bore diameter	<b>E</b> = Gap width between left and right component	<b>G<sub>wub</sub></b> = Weight, unbored
<b>n<sub>b7</sub></b> = Quantity of bore d <sub>7</sub>	<b>F<sub>E</sub></b> = Tolerance of the gap width E	

### Ordering example

Series	Size	Buffer	d <sub>1f</sub>	Further details <sup>*)</sup>
TNR 2424.2	260.2 - 14.0	Pb 70/Pb 60	80	*

<sup>\*)</sup> Without any other specification, we deliver as a standard: with set screws and keyway acc. to DIN 6885-1, keyway side fit P9, bore tolerance H7

Further information on  
**RINGFEDER® TNR 2424.2**  
 on [www.ringfeder.com](http://www.ringfeder.com)

#### Disclaimer of liability

All technical details and notes are non-binding and cannot be used as a basis for legal claims. The user is obligated to determine whether the represented products meet his requirements. We reserve the right carry out modifications at any time in the interests of technical progress.

# Torsional Highflex Couplings

## RINGFEDER® TNR 2425.1

Single-row, SAE flange-shaft connections with taper clamping bush

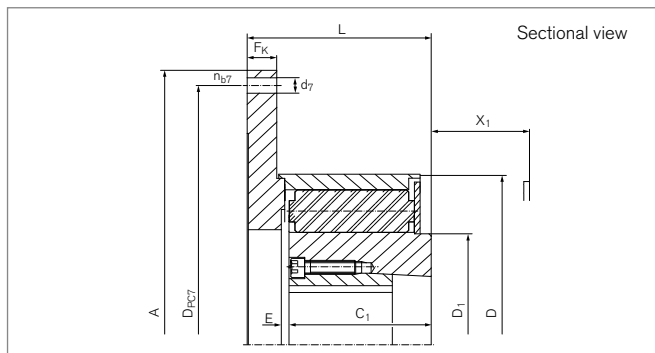

Size	Taper bushing	SAE size	A	D <sub>PC7</sub>	d <sub>7</sub>	n <sub>b7</sub>	D	D <sub>1</sub>	C <sub>1</sub>
			mm	mm	mm		mm	mm	mm
120.1 - 06.5	1615	6,5	215,9	200,0	9,5	6	120	73	52,0
120.1 - 07.5	1615	7,5	241,3	222,3	9,5	8	120	73	52,0
120.1 - 08.0	1615	8,0	263,5	244,5	11,0	6	120	73	52,0
120.1 - 10.0	1615	10,0	314,3	295,3	11,0	8	120	73	52,0
160.1 - 06.5	2012	6,5	215,9	200,0	9,5	6	160	100	64,0
160.1 - 07.5	2012	7,5	241,3	222,3	9,5	8	160	100	64,0
160.1 - 08.0	2012	8,0	263,5	244,5	11,0	6	160	100	64,0
160.1 - 10.0	2012	10,0	314,3	295,3	11,0	8	160	100	64,0
200.1 - 07.5	2517	7,5	222,3	213,3	9,5	8	200	129	80,0
200.1 - 08.0	2517	8,0	263,5	244,5	11,0	6	200	129	80,0
200.1 - 10.0	2517	10,0	314,3	295,3	11,0	8	200	129	80,0
200.1 - 11.5	2517	11,5	352,4	333,7	11,0	8	200	129	80,0
260.1 - 10.0	3535	10,0	314,3	295,3	11,0	8	260	165	100,0
260.1 - 11.5	3535	11,5	352,4	333,7	11,0	8	260	165	100,0
260.1 - 14.0	3535	14,0	466,7	438,2	14,5	8	260	165	100,0
260.1 - 16.0	3535	16,0	517,5	489,0	14,5	8	260	165	100,0
320.1 - 14.0	4040	14,0	466,7	438,2	14,5	8	320	208	125,0
320.1 - 16.0	4040	16,0	517,5	489,0	14,5	8	320	208	125,0
320.1 - 18.0	4040	18,0	571,5	542,9	18,0	6	320	208	125,0
400.1 - 16.0	5050	16,0	517,5	489,0	14,5	8	400	268	156,0
400.1 - 18.0	5050	18,0	571,5	542,9	18,0	6	400	268	156,0
400.1 - 21.0	5050	21,0	673,1	641,4	18,0	12	400	268	156,0
400.1 - 24.0	5050	24,0	733,4	692,2	22,0	12	400	268	156,0

Taper bushing bore see chapter „Ordering example“ in Product Paper & Tech Paper „RINGFEDER® Torsional Highflex Couplings“

To continue see next page



### Torsional Highflex Couplings RINGFEDER® TNR 2425.1

Size	L	E	F <sub>E</sub>	F <sub>K</sub>	X <sub>1</sub>	J <sub>F</sub>	J <sub>N</sub> <sup>1)</sup>	G <sub>wub</sub> <sup>1)</sup>
	mm	mm	mm	mm	mm	10 <sup>-3</sup> kgm <sup>2</sup>	10 <sup>-3</sup> kgm <sup>2</sup>	kg
120.1 - 06.5	71	4,0	+/- 1,0	13	41	6	1,4	2,8
120.1 - 07.5	71	4,0	+/- 1,0	13	41	9	1,4	3,1
120.1 - 08.0	71	4,0	+/- 1,0	13	41	12	1,4	3,4
120.1 - 10.0	71	4,0	+/- 1,0	13	41	26	1,4	4,1
160.1 - 06.5	84	4,0	+/- 1,0	15	50	9	7,6	5,3
160.1 - 07.5	84	4,0	+/- 1,0	15	50	12	7,6	5,6
160.1 - 08.0	84	4,0	+/- 1,0	15	50	16	7,6	5,9
160.1 - 10.0	84	4,0	+/- 1,0	15	50	31	7,6	6,8
200.1 - 07.5	104	5,0	+/- 1,5	18	64	23	24	10,2
200.1 - 08.0	104	5,0	+/- 1,5	18	64	28	24	10,6
200.1 - 10.0	104	5,0	+/- 1,5	18	64	45	24	11,6
200.1 - 11.5	104	5,0	+/- 1,5	18	64	66	24	12,6
260.1 - 10.0	132	6,0	+/- 1,5	24	80	92	80	20,3
260.1 - 11.5	132	6,0	+/- 1,5	24	80	118	80	21,5
260.1 - 14.0	132	6,0	+/- 1,5	24	80	260	80	25,6
260.1 - 16.0	132	6,0	+/- 1,5	24	80	381	80	28,0
320.1 - 14.0	162	7,0	+/- 2,0	26	100	474	275	44,6
320.1 - 16.0	162	7,0	+/- 2,0	26	100	662	275	47,2
320.1 - 18.0	162	7,0	+/- 2,0	26	100	1195	275	50,3
400.1 - 16.0	197	8,0	+/- 2,0	31	126	760	897	83,9
400.1 - 18.0	197	8,0	+/- 2,0	31	126	971	897	87,6
400.1 - 21.0	197	8,0	+/- 2,0	31	126	1579	897	95,2
400.1 - 24.0	197	8,0	+/- 2,0	31	126	2035	897	99,7

<sup>1)</sup> Weight and mass moment of inertia for hubs without taper lock bushing

### Explanations

<b>SAE</b> = Flange connection to SAE J 620 d	<b>D<sub>1</sub></b> = Outer diameter	<b>X<sub>1</sub></b> = Required space for dismounting of the elastic buffer
<b>A</b> = Max. outer diameter	<b>C<sub>1</sub></b> = Guided length in hub bore	<b>J<sub>F</sub></b> = Moment of inertia on thrust flange side
<b>D<sub>PC7</sub></b> = Pitch circle diameter of bore holes d <sub>7</sub>	<b>L</b> = Total length	<b>J<sub>N</sub></b> = Moment of inertia hub side
<b>d<sub>7</sub></b> = Bore diameter	<b>E</b> = Gap width between left and right component	<b>G<sub>wub</sub></b> = Weight, unbored
<b>n<sub>b7</sub></b> = Quantity of bore d <sub>7</sub>	<b>F<sub>E</sub></b> = Tolerance of the gap width E	
<b>D</b> = Outer diameter	<b>F<sub>K</sub></b> = Flange thickness	

### Ordering example

Series	Size	Buffer	Taper bushing	Bore taper bushing
TNR 2425.1	200.1 - 08.0	Pb 70	2517	28

Further information on  
**RINGFEDER® TNR 2425.1**  
 on [www.ringfeder.com](http://www.ringfeder.com)

#### Disclaimer of liability

All technical details and notes are non-binding and cannot be used as a basis for legal claims. The user is obligated to determine whether the represented products meet his requirements. We reserve the right carry out modifications at any time in the interests of technical progress.

# Torsional Highflex Couplings

## RINGFEDER® TNR 2425.2

Two-row, SAE flange-shaft connections with taper clamping bush

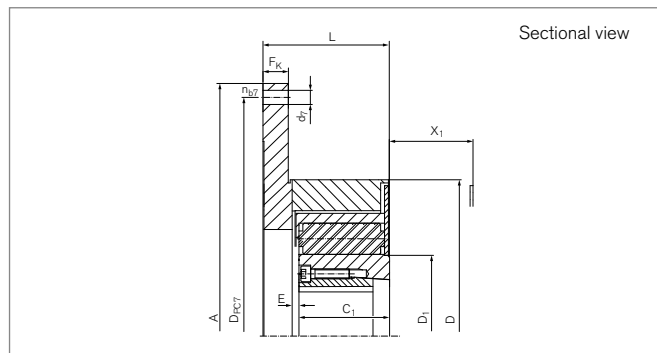

Size	Taper bushing	SAE Size	A	D <sub>pc7</sub>	d <sub>7</sub>	n <sub>b7</sub>	D	D <sub>1</sub>	C <sub>1</sub>
			mm	mm	mm		mm	mm	mm
160.2 - 06.5	1615	6,5	215,9	200,0	9,5	6	160	73	52,0
160.2 - 07.5	1615	7,5	241,3	222,3	9,5	8	160	73	52,0
160.2 - 08.0	1615	8,0	263,5	244,5	11,0	6	160	73	52,0
160.2 - 10.0	1615	10,0	314,3	295,3	11,0	8	160	73	52,0
200.2 - 07.5	2012	7,5	222,3	213,3	9,5	8	200	100	64,0
200.2 - 08.0	2012	8,0	263,5	244,5	11,0	6	200	100	64,0
200.2 - 10.0	2012	10,0	314,3	295,3	11,0	8	200	100	64,0
200.2 - 11.5	2012	11,5	352,4	333,7	11,0	8	200	100	64,0
260.2 - 10.0	2517	10,0	314,3	295,3	11,0	8	260	129	80,0
260.2 - 11.5	2517	11,5	352,4	333,7	11,0	8	260	129	80,0
260.2 - 14.0	2517	14,0	466,7	438,2	14,5	8	260	129	80,0
260.2 - 16.0	2517	16,0	517,5	489,0	14,5	8	260	129	80,0
320.2 - 14.0	3535	14,0	466,7	438,2	14,5	8	320	165	100,0
320.2 - 16.0	3535	16,0	517,5	489,0	14,5	8	320	165	100,0
320.2 - 18.0	3535	18,0	571,5	542,9	18,0	6	320	165	100,0
400.2 - 16.0	4040	16,0	517,5	489,0	14,5	8	400	208	125,0
400.2 - 18.0	4040	18,0	571,5	542,9	18,0	6	400	208	125,0
400.2 - 21.0	4040	21,0	673,1	641,4	18,0	12	400	208	125,0
400.2 - 24.0	4040	24,0	733,4	692,2	22,0	12	400	208	125,0
500.2 - 21.0	5050	21,0	673,1	641,4	18,0	12	500	268	156,0
500.2 - 24.0	5050	24,0	733,4	692,2	22,0	12	500	268	156,0

Taper bushing bore see chapter „Ordering example“ in Product Paper & Tech Paper „RINGFEDER® Torsional Highflex Couplings“

To continue see next page

**Torsional Highflex Couplings RINGFEDER® TNR 2425.2**

Size	L	E	F <sub>E</sub>	F <sub>K</sub>	X <sub>1</sub>	J <sub>F</sub>	J <sub>N</sub> <sup>1)</sup>	G <sub>wub</sub> <sup>1)</sup>
	mm	mm	mm	mm	mm	10 <sup>-3</sup> kgm <sup>2</sup>	10 <sup>-3</sup> kgm <sup>2</sup>	kg
160.2 - 06.5	71	4,0	-1,0	15	41	10	9	3,7
160.2 - 07.5	71	4,0	-1,0	15	41	13	12	4,0
160.2 - 08.0	71	4,0	-1,0	15	41	17	16	4,3
160.2 - 10.0	71	4,0	-1,0	15	41	32	31	5,2
200.2 - 07.5	84	5,0	-1,5	18	50	21	18	6,8
200.2 - 08.0	84	5,0	-1,5	18	50	26	23	7,2
200.2 - 10.0	84	5,0	-1,5	18	50	43	40	8,3
200.2 - 11.5	84	5,0	-1,5	18	50	64	61	9,2
260.2 - 10.0	104	6,0	-1,5	24	64	86	76	15,2
260.2 - 11.5	104	6,0	-1,5	24	64	112	102	16,4
260.2 - 14.0	104	6,0	-1,5	24	64	254	244	20,5
260.2 - 16.0	104	6,0	-1,5	24	64	375	365	22,9
320.2 - 14.0	132	7,0	-2,0	26	80	464	302	30,1
320.2 - 16.0	132	7,0	-2,0	26	80	652	428	32,7
320.2 - 18.0	132	7,0	-2,0	26	80	1185	616	35,7
400.2 - 16.0	162	8,0	-2,0	31	100	740	640	57,1
400.2 - 18.0	162	8,0	-2,0	31	31	951	851	60,7
400.2 - 21.0	162	8,0	-2,0	31	100	1559	1459	68,4
400.2 - 24.0	162	8,0	-2,0	31	100	2015	1915	72,8
500.2 - 21.0	197	10,0	-2,5	34	126	2327	1950	114,0
500.2 - 24.0	197	10,0	-2,5	34	126	2802	2425	118,0

<sup>1)</sup> Weight and mass moment of inertia for hubs without taper lock bushing

## Explanations

<b>SAE</b> = Flange connection to SAE J 620 d	<b>D<sub>1</sub></b> = Outer diameter	<b>X<sub>1</sub></b> = Required space for dismounting of the elastic buffer
<b>A</b> = Max. outer diameter	<b>C<sub>1</sub></b> = Guided length in hub bore	<b>J<sub>F</sub></b> = Moment of inertia on thrust flange side
<b>D<sub>PC7</sub></b> = Pitch circle diameter of bore holes d <sub>7</sub>	<b>L</b> = Total length	<b>J<sub>N</sub></b> = Moment of inertia hub side
<b>d<sub>7</sub></b> = Bore diameter	<b>E</b> = Gap width between left and right component	<b>G<sub>wub</sub></b> = Weight, unbored
<b>n<sub>b7</sub></b> = Quantity of bore d <sub>7</sub>	<b>F<sub>E</sub></b> = Tolerance of the gap width E	
<b>D</b> = Outer diameter	<b>F<sub>K</sub></b> = Flange thickness	

## Ordering example

Series	Size	Buffer	Taper bushing	Bore taper bushing
TNR 2425.2	260.2 - 14.0	Pb 70/Pb 60	2517	28

Further information on  
**RINGFEDER® TNR 2425.2**  
 on [www.ringfeder.com](http://www.ringfeder.com)

### Disclaimer of liability

All technical details and notes are non-binding and cannot be used as a basis for legal claims. The user is obligated to determine whether the represented products meet his requirements. We reserve the right carry out modifications at any time in the interests of technical progress.

# Torsional Highflex Couplings

## RINGFEDER® TNR 2428.1

### Single-row, shaft-shaft connections

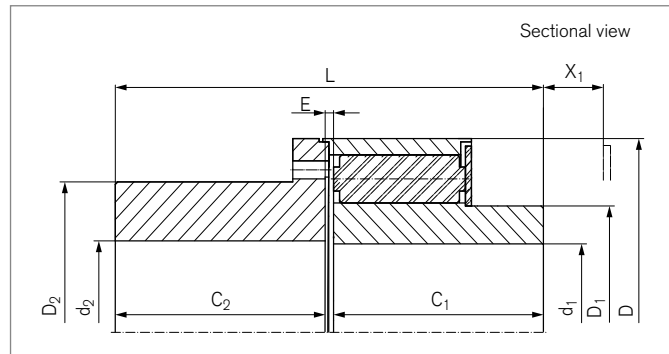
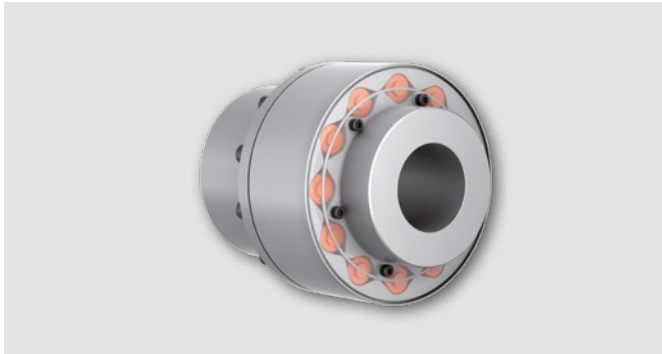

Size	$d_{1f \max}$	$d_{2f \max}$	D	D <sub>1</sub>	D <sub>2</sub>	C <sub>1</sub>	C <sub>2</sub>
	mm	mm	mm	mm	mm	mm	mm
120.1	50	55	120	73	85	65	65
160.1	70	75	160	100	115	90	90
200.1	90	105	200	129	155	115	115
260.1	115	130	260	165	195	140	140
320.1	145	165	320	210	245	175	175
400.1	185	215	400	275	305	230	230
500.1	230	250	500	335	350	300	300
640.1	300	320	640	430	450	380	380

Size	L	E	F <sub>E</sub>	X <sub>1</sub>	J <sub>F</sub>	J <sub>N</sub> <sup>1)</sup>	G <sub>w<sub>ub</sub></sub> <sup>1)</sup>
	mm	mm	mm	mm	10 <sup>-3</sup> kgm <sup>2</sup>	10 <sup>-3</sup> kgm <sup>2</sup>	kg
120.1	134	4	+/- 1,0	28	5	2	6,7
160.1	184	4	+/- 1,0	23	23	11	16,3
200.1	235	5	+/- 1,5	28	83	35	34,9
260.1	286	6	+/- 1,5	40	274	116	69,7
320.1	357	7	+/- 2,0	50	804	375	137,0
400.1	468	8	+/- 2,0	52	2383	1274	278,0
500.1	610	10	+/- 2,5	60	6175	4155	527,0
640.1	775	15	+/- 4,5	68	21314	13355	1088,0

<sup>1)</sup> Weight and moment of inertia for unbored hubs

To continue see next page

## Torsional Highflex Couplings RINGFEDER® TNR 2428.1

### Explanations

<b>d<sub>1f max</sub></b> = Max. bore diameter d <sub>1</sub> with keyway acc. to ANSI B17.1	<b>D<sub>2</sub></b> = Outer diameter hub	<b>F<sub>E</sub></b> = Tolerance of the gap width E
<b>d<sub>2f max</sub></b> = Max. bore diameter d <sub>2</sub> with keyway acc. to ANSI B17.1	<b>C<sub>1</sub></b> = Guided length in hub bore	<b>X<sub>1</sub></b> = Required space for dismounting of the elastic buffer
<b>D</b> = Outer diameter	<b>C<sub>2</sub></b> = Guided length in hub bore	<b>J<sub>F</sub></b> = Moment of inertia on thrust flange side
<b>D<sub>1</sub></b> = Outer diameter	<b>L</b> = Total length	<b>J<sub>N</sub></b> = Moment of inertia hub side
	<b>E</b> = Gap width between left and right component	<b>G<sub>wub</sub></b> = Weight, unbored

### Ordering example

Series	Size	Buffer	d <sub>1f</sub>	d <sub>2f</sub>	Further details <sup>*)</sup>
TNR 2428.1	260.1	Vk 90	100	90	*

<sup>\*)</sup> Without any other specification, we deliver as a standard: with set screws and keyway acc. to DIN 6885-1, keyway side fit P9, bore tolerance H7

Further information on  
**RINGFEDER® TNR 2428.1**  
 on [www.ringfeder.com](http://www.ringfeder.com)

#### Disclaimer of liability

All technical details and notes are non-binding and cannot be used as a basis for legal claims. The user is obligated to determine whether the represented products meet his requirements. We reserve the right carry out modifications at any time in the interests of technical progress.

# Torsional Highflex Couplings

## RINGFEDER® TNR 2428.2

Two-row, shaft-shaft connections

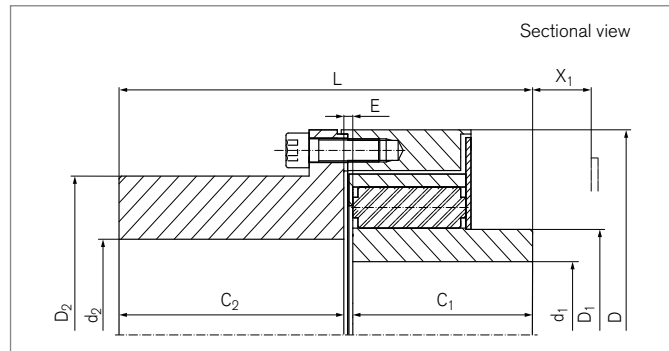

Size	$d_{1f \max}$	$d_{2f \max}$	D	D <sub>1</sub>	D <sub>2</sub>	C <sub>1</sub>	C <sub>2</sub>
	mm	mm	mm	mm	mm	mm	mm
160.2	50	75	160	73	115	65	90
200.2	70	105	200	100	155	90	115
260.2	90	130	260	129	195	115	140
320.2	115	165	320	165	245	140	175
400.2	145	215	400	210	305	175	230
500.2	185	250	500	275	350	230	300
640.2	230	320	640	335	450	300	380

Size	L	E	F <sub>E</sub>	X <sub>1</sub>	J <sub>F</sub>	J <sub>N</sub> <sup>1)</sup>	G <sub>wub</sub> <sup>1)</sup>
	mm	mm	mm	mm	10 <sup>-3</sup> kgm <sup>2</sup>	10 <sup>-3</sup> kgm <sup>2</sup>	kg
160.2	159	4	-1,0	28	23	3	12,8
200.2	210	5	-1,5	23	81	14	28,1
260.2	261	6	-1,5	28	268	44	56,6
320.2	322	7	-2,0	40	794	144	110,0
400.2	413	8	-2,0	50	2363	462	219,0
500.2	540	10	-2,5	52	6100	1544	409,0
640.2	695	15	-4,5	60	21052	5100	855,0

<sup>1)</sup> Weight and moment of inertia for unbored hubs

To continue see next page

## Torsional Highflex Couplings RINGFEDER® TNR 2428.2

### Explanations

<b>d<sub>1f max</sub></b> = Max. bore diameter d <sub>1</sub> with keyway acc. to ANSI B17.1	<b>D<sub>2</sub></b> = Outer diameter hub	<b>F<sub>E</sub></b> = Tolerance of the gap width E
<b>d<sub>2f max</sub></b> = Max. bore diameter d <sub>2</sub> with keyway acc. to ANSI B17.1	<b>C<sub>1</sub></b> = Guided length in hub bore	<b>X<sub>1</sub></b> = Required space for dismounting of the elastic buffer
<b>D</b> = Outer diameter	<b>C<sub>2</sub></b> = Guided length in hub bore	<b>J<sub>F</sub></b> = Moment of inertia on thrust flange side
<b>D<sub>1</sub></b> = Outer diameter	<b>L</b> = Total length	<b>J<sub>N</sub></b> = Moment of inertia hub side
	<b>E</b> = Gap width between left and right component	<b>G<sub>wub</sub></b> = Weight, unbored

### Ordering example

Series	Size	Buffer	d <sub>1f</sub>	d <sub>2f</sub>	Further details*)
TNR 2428.2	260.2	Vk 90/Vk 80	80	120	*

\*) Without any other specification, we deliver as a standard: with set screws and keyway acc. to DIN 6885-1, keyway side fit P9, bore tolerance H7

Further information on  
**RINGFEDER® TNR 2428.2**  
 on [www.ringfeder.com](http://www.ringfeder.com)

#### Disclaimer of liability

All technical details and notes are non-binding and cannot be used as a basis for legal claims. The user is obligated to determine whether the represented products meet his requirements. We reserve the right carry out modifications at any time in the interests of technical progress.

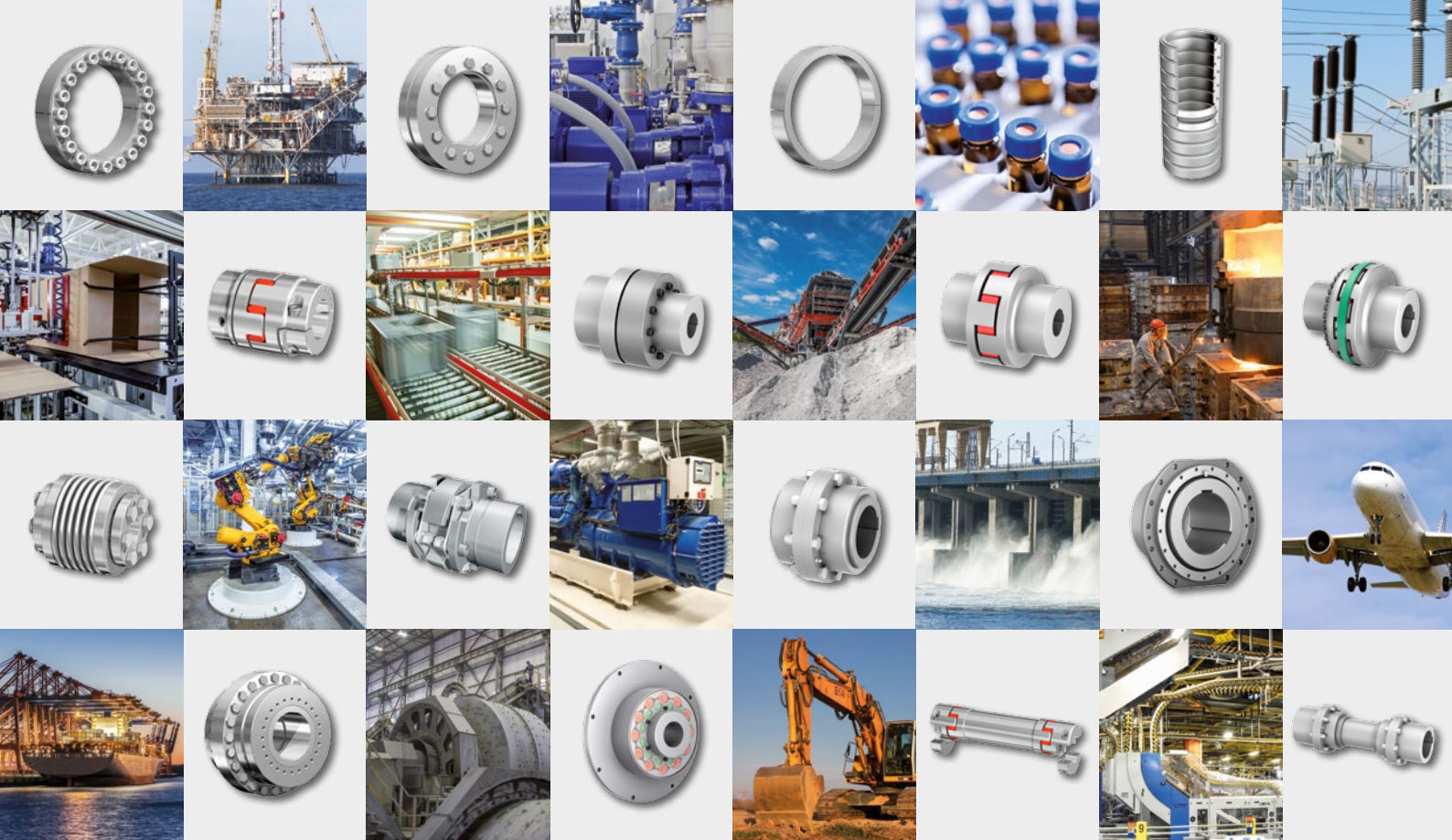

**RINGFEDER POWER TRANSMISSION GMBH**

Werner-Heisenberg-Straße 18, D-64823 Groß-Umstadt, Germany · Phone: +49 (0) 6078 9385-0 · Fax: +49 (0) 6078 9385-100  
E-mail: sales.international@ringfeder.com

**RINGFEDER POWER TRANSMISSION TSCHAN GMBH**

Zweibrücker Straße 104, D-66538 Neunkirchen, Germany · Phone: +49 (0) 6821 866-0 · Fax: +49 (0) 6821 866-4111  
E-mail: sales.tschan@ringfeder.com

**RINGFEDER POWER TRANSMISSION USA CORPORATION**

165 Carver Avenue, Westwood, NJ 07675, USA · Toll Free: +1 888 746-4333 · Phone: +1 201 666 3320 · Fax: +1 201 664 6053  
E-mail: sales.usa@ringfeder.com

**HENFEL INDÚSTRIA METALÚRGICA LTDA.**

Av. Major Hilário Tavares Pinheiro, 3447 · CEP 14871 300 · Jabcoticabal - SP - Brazil · Phone: +55 (16) 3209-3422  
E-mail: vendas@henfel.com.br

**RINGFEDER POWER TRANSMISSION INDIA PRIVATE LIMITED**

Plot No. 4, Door No. 220, Mount - Poonamallee Road, Kattupakkam, Chennai – 600 056, India  
Phone: +91 (0) 44-2679 1411 · Fax: +91 (0) 44-2679 1422 · E-mail: sales.india@ringfeder.com

**KUNSHAN RINGFEDER POWER TRANSMISSION COMPANY LIMITED**

NO. 406 Jiande Road, Zhangpu 215321, Kunshan, Jiangsu Province, China  
Phone: +86 (0) 512-5745-3960 · Fax: +86 (0) 512-5745-3961 · E-mail: sales.china@ringfeder.com

Partner for Performance  
[www.ringfeder.com](http://www.ringfeder.com)

