

Air valve(5/2 way, 5/3 way)

4A100 Series

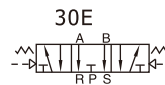
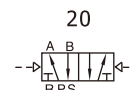
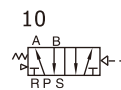

Ordering code

4A 1 10 06 T

① ② ③ ④ ⑤

① Model

4A: Air valve
(5/2, 5/3 way)

② Code

1: 100 Series

③ Valve type

10: Single air control 5/2 way
20: Double air control 5/2 way
30C: Double air control 5/3 way
closed center
30E: Double air control 5/3 way
exhaust center
30P: Double air control 5/3 way
pressure center

④ Port size

M5: M5
06: 1/8"

⑤ Thread type

No this code(M5)
T: NPT

Please refer to P126 for manifold specification and the order way.

Specification

Model	4A110-M5 4A120-M5	4A130C-M5 4A130E-M5 4A130P-M5	4A110-06 4A120-06	4A130C-06 4A130E-06 4A130P-06
Fluid	Air(to be filtered by 40μm filter element)			
Acting	Exterior control			
Port size [Note1]	In=Out=M5		In=Out=1/8"	
Orifice size [Note4]	4A110-06,4A120-06:10.2mm ² (Cv=0.6) 4A130C-06:8.6mm ² (Cv=0.51)			
Valve type	5 port 2 position	5 port 3 position	5 port 2 position	5 port 3 position
Operating pressure	21~114psi(0.15~0.8MPa)			
Proof pressure	175psi(1.2MPa)			
Temperature	-20~70°C			
Material of body	Aluminum alloy			
Lubrication [Note2]	Not required			
Max.frequency [Note3]	5 cycle/sec	3cycle/sec	5 cycle/sec	3 cycle/sec
Weight (g)	4A110-M5:85 4A120-M5:140	165	4A110-06:85 4A120-06:140	165

[Note1] NPT thread is available.

[Note2] Once lubricated air is used, continue with same medium to optimize valve life span.
Lubricants like ISO VG32 or equivalent are recommended.

[Note3] The maximum actuation frequency is in the no-load state.

[Note4] Equivalent orifice S and Cv are all calculated from the flow rate data.

4A100 Series

Product feature

1. Structure in sliding column mode: good tightness and sensitive reaction.
2. Three position air valves have three kinds of central function for your choice.
3. Double air control valves have memory function.
4. Internal hole adopts special processing technology which has little attrition friction, low start pressure and long service life.
5. No need to add oil for lubrication.
6. Integrate with the manifold to save installation space.

Flow chart

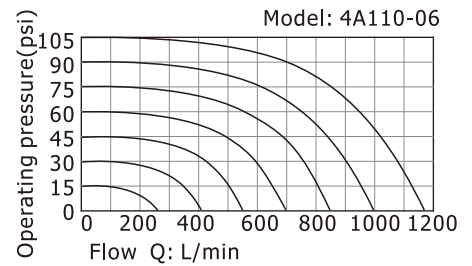

The data in flow rate chart are obtained from AirTAC lab.

Inner structure

4A110

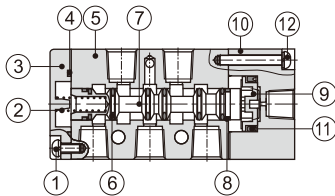

4A120

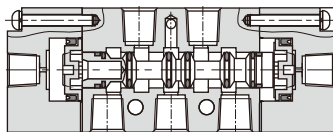

4A130C

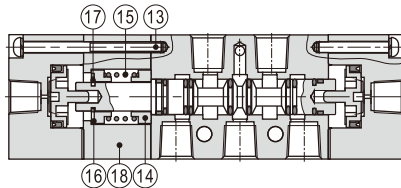

No.	Item	No.	Item	No.	Item
1	Screw	7	Spool	13	Screw
2	Spring	8	Wear ring	14	Spring holder
3	Bottom cover	9	Piston	15	Return Spring
4	Bottom cover gasket	10	Pilot body	16	Spring holder
5	Body	11	O-ring	17	E Clip
6	O-ring	12	Screw	18	Side cover

Air valve(5/2 way, 5/3 way)

4A100 Series

Dimensions

4A110

[Unit: mm]

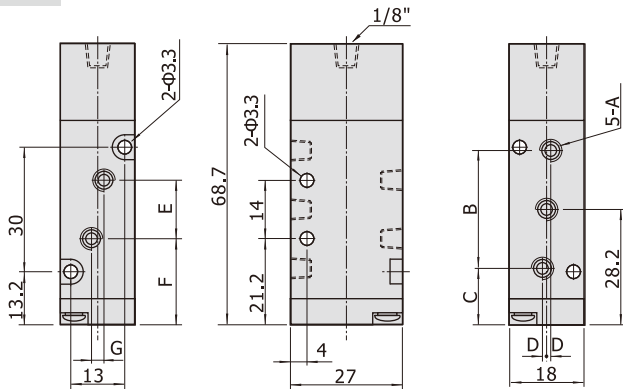

Model\Item	A	B	C	D	E	F	G
4A110-M5	M5x0.8	27	14.7	0	14	21.2	0
4A110-06	1/8"	28	14.2	1	16	20.2	3

4A120

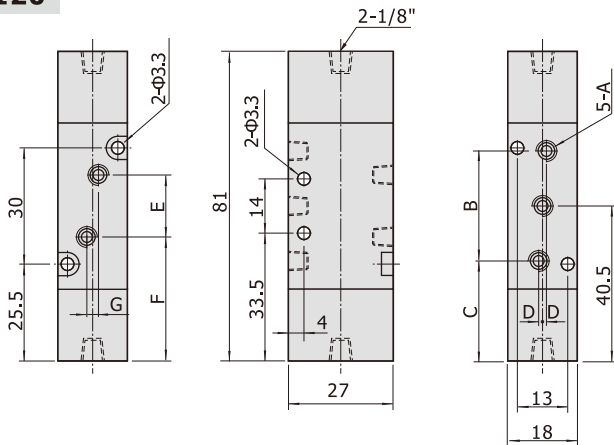

Model\Item	A	B	C	D	E	F	G
4A120-M5	M5x0.8	27	27	0	14	33.5	0
4A120-06	1/8"	28	26.5	1	16	32.5	3

4A130

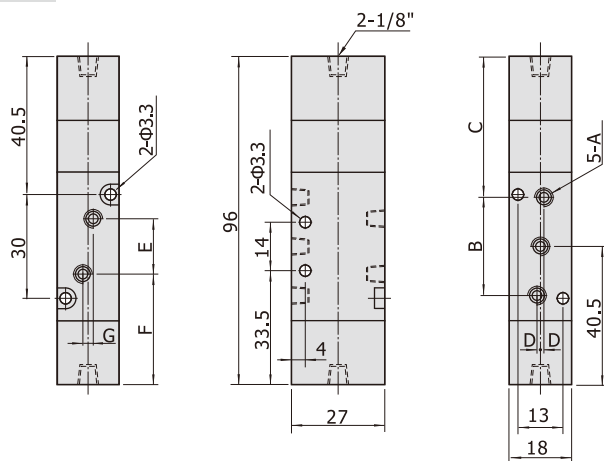

Model\Item	A	B	C	D	E	F	G
4A130-M5	M5x0.8	27	42	0	14	33.5	0
4A130-06	1/8"	28	41.5	1	16	32.5	3