

ELTIM

Inline basis weight measurement
Inline thickness measurement

Continuous acquisition and recording of
the basis weight and thickness

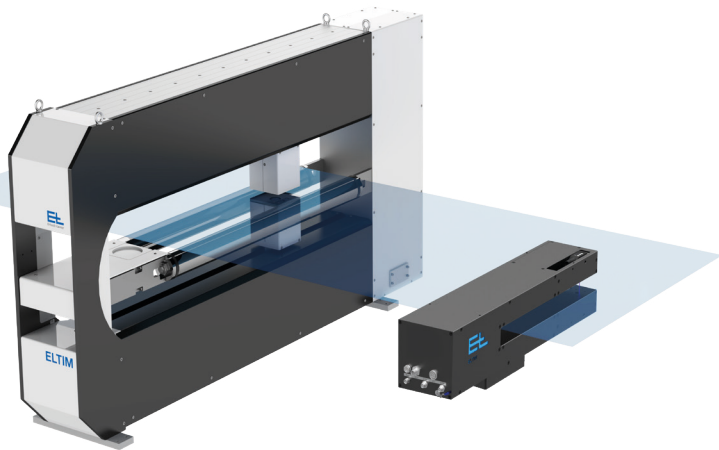

NO RISK
from radiation

Contents

Higher quality through basis weight measurement	4
Basis weight measuring system ELTIM	5
Sensors	5
ELTIM BWS10 O-frame	6
ELTIM BWS15/17 C-frame	8
Control and data management software ELQ	10
Expansion options	12
Application examples	14
Application example: detecting delamination	15
ROI with ELTIM – three steps to efficiency	16
Sample examination with customer material	17
Questionnaire, basis weight and thickness measurement	18

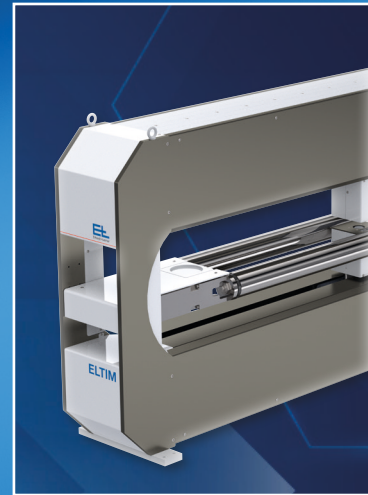
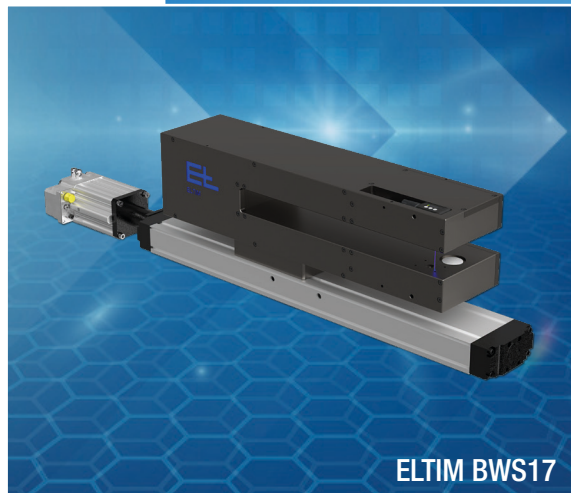

FOCUS ON CUSTOMER SATISFACTION

INTELLIGENT TECHNOLOGY · SMART PRODUCTS

INTERNATIONAL LOCATIONS · WORLDWIDE AVAILABILITY

CUTTING-EDGE TECHNOLOGY – AT HOME ALL OVER THE WORLD



ELTIM BWS10

Erhardt+Leimer

Global solutions for production of the future

Intelligent technologies and products in the highest quality designed to optimize the production processes of our customers all around the world. This is our claim as the internationally expanding Erhardt+Leimer group of companies.

With our global presence – from development to production and on to service – we are always close to the customer. We develop customer-specific solutions and provide our customers with excellent products either in digital or intelligent versions depending on their preference. Not only this, but we also set new standards for the production of tomorrow. In the process, it is not just our products that are increasingly becoming smart – our entire company is currently undergoing a digital transformation. One visible indication of this is the E+L online shop, which enables our customers to order products and spare parts quickly and easily from our website.

With more than 1,600 employees at sites across Europe, Asia, and America we deliver cutting-edge technology on-time to any location in the world.

In everything we do, we aim to use all company resources responsibly to protect the environment and demonstrate our commitment to increased sustainability.



Higher quality through basis weight measurement

Advantages of basis weight measurement

In all production processes, the quality of the materials must be ensured in the end, and any potential for optimization in manufacturing must be identified immediately. The ELTIM system allows precise determination of material distribution and of the amount of material consumed from the web based on the weight. This information enables customers to optimize energy consumption and save costs by reducing material usage.

Unlike other basis weight measuring systems, ELTIM does not use X-rays or radioactive isotopes for measurement. The system works with ultrasonic sensors and can be integrated into existing production lines with considerably less time and cost. In addition, the ultrasound-based, radiation-free sensor reduces occupational health & safety requirements and eliminates the danger of environmental damage due to unresolved radioactive waste disposal issues.

Can be used in the following applications

- Film extrusion
- Calendering
 - Floor coverings (e.g. PVC)
 - Rubber manufacture
 - Technical films/foils
- **Converting**
 - Lamination
 - Coating
 - Adhesive tapes
 - Paper converting
 - Lithium-ion batteries
 - Fuel cells
 - Photovoltaic cells
 - Painting
 - Printed electronics
 - Film stretching machines
 - Abrasives
 - Medical products

These materials can be measured



Plastic films (PE, PP, EVA, PVC, PVB, etc.)



Metal foils (aluminum, copper, etc.)



Batteries, fuel cells



Paper



All types of coating (e.g. adhesive tapes)



Abrasives



Composite non-woven fabrics (e.g. non-woven membrane fabrics, textiles)



Wallpapers

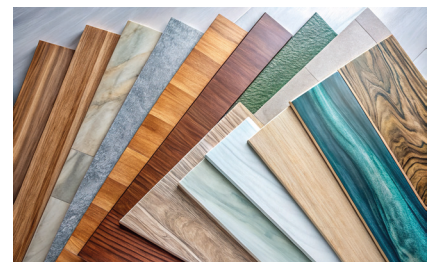

Floor coverings and roofing membranes

Other materials on request

Basis weight measurement system ELTIM

ELTIM is an ultrasound-based, radiation-free sensor for the contactless determination of the basis weight of materials produced as flat webs. It offers the highest accuracy, especially for thin materials with high frequencies and a small detection area. In addition, special sensors record data such as ambient and material temperatures, atmospheric humidity, or air pressure.

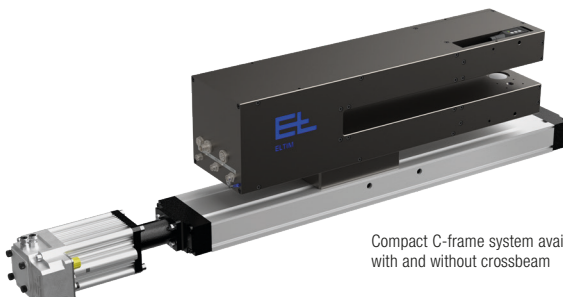

Compact C-frame system available with and without crossbeam

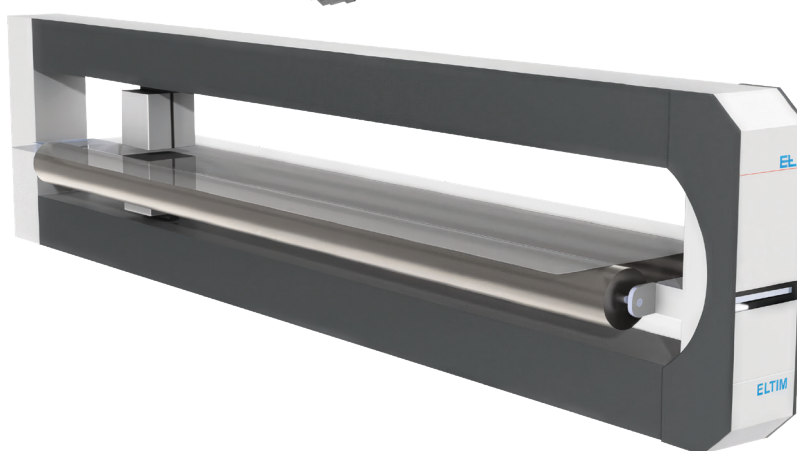

Traversing O-frame system for large web widths

Sensors

Principle of the ultrasonic measuring process

In this process, the absorption of an ultrasonic pulse as it propagates through a fabric web is determined without contact using an ultrasonic transmitter and an ultrasonic receiver. The basis weight is calculated from the absorption and a calibration factor.

Legend

- 1 Transmitter
- 2 Ultrasonic transducer
- 3 Environmental sensor system
- 4 Receiver
- 5 Support rollers

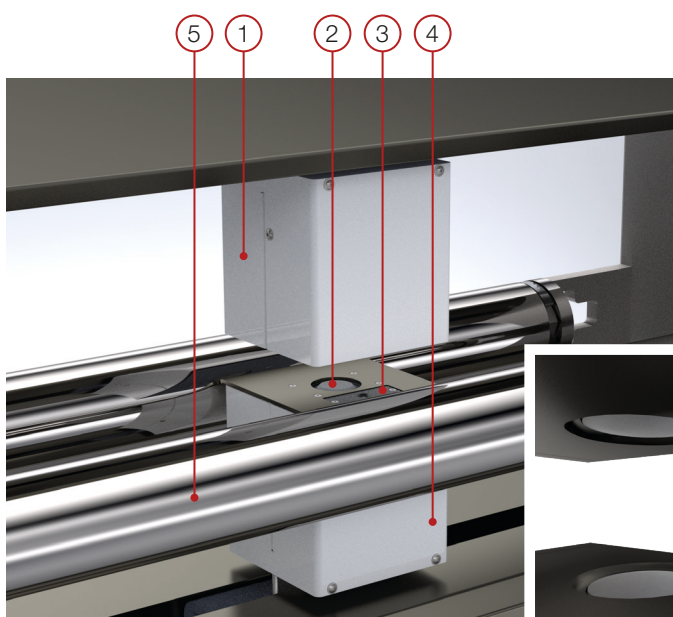

ELTIM O-frame sensor system

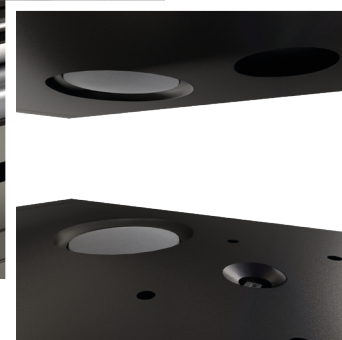

ELTIM C-frame sensor system

ELTIM BWS10 O-frame

- No danger from radiometric radiation or X-rays
- Compact system, easy to integrate in existing machines
- Small detection area for highest accuracy
- Sensors for detection of ambient conditions that might potentially impact on processes
- Insensitive to fluctuations in the web height
- Unaffected even by color fluctuations
- Maintenance-free transmitter and scanner
- Exceptionally user-friendly graphical user interface
- Machine interfaces for every customer control system
- Doctor blade control or applicator roller control depending on customer preference
- Extensive analysis software such as 3D surface profile display
- Continuous air and material recalibration for highest measuring equipment reproducibility (e.g. for compliance with DIN ISO 9001)
- Identification of coated surfaces via contrast sensors (for intermittent coating on top or underside)
- Same spot measurement for highly accurate determination of the basis weights of coatings, for example
- ATEX – EU directive on explosion protection: ELTIM systems will in future also be available in a special version for explosion hazard areas. Ex zones and version on request

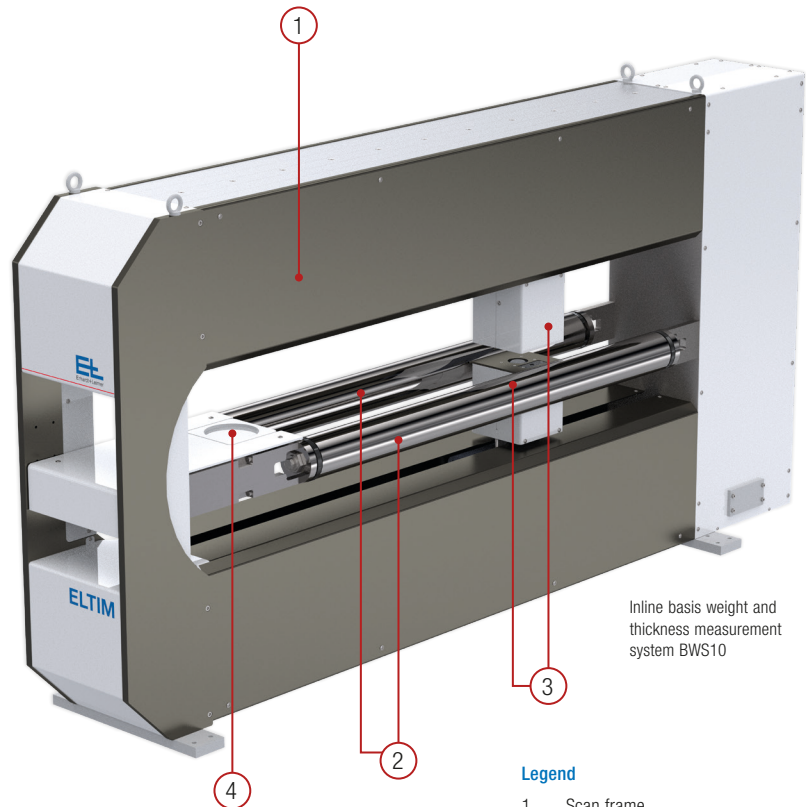

Inline basis weight and thickness measurement system BWS10

Legend

- 1 Scan frame
- 2 Support rollers
- 3 Scanning heads
- 4 Calibration table for reference material

General functions

Measurement of the basis weight (current, average, min. & max., basis weight profile over the entire width)

Comparison of nominal and measured values

Tolerances	Tolerances for warning and alarm if target exceeded or dropped below
Data output	To PLC, to ELQ, to I/O
User levels/pass-word	Operator level: Limited access rights Engineer level: Full access rights
WBM interface	Web-based administration Configuration and value display accessible via web browser

Technical data

Measuring range (basis weight measurement)	Up to 4000 g/m ²
Measuring accuracy	< ±0.5 % of the basis weight of the calibration piece
Resolution	0.001 g/m ²
Sensor type	US ultrasonic sensor
Measuring point size	Ø 25 mm
Cycle time of the measuring system	120 Hz
Passage height	40 mm (from measuring head to measuring head)
Height fluctuation of the web	±5 mm in the middle; no fluttering
Max. actuating speed of sensor	300 mm/s
Relative humidity	max. 95 % (non-condensing)
Ambient temperature	+10 °C to +50 °C
Ambient temperature at the sensor	+10 °C to +70 °C
Storage temperature	-20 °C to +80 °C
Protection rating / certification	IP 54, UL 50e: type 12
Operating voltage	24 V DC, 10 A
Nominal width (NW)	500 mm to 2500 mm (larger widths on request)
Dimensions	L (NW + 932 mm) x H 960 mm x D 270 mm

Support rollers for improved web guiding

Erhardt+Leimer offers two support rollers for stabilizing the web. In this way, fluctuations in the height of the material are reduced and the measured result optimized. Here it is to be noted that the rollers are each subject to slight wrapping.

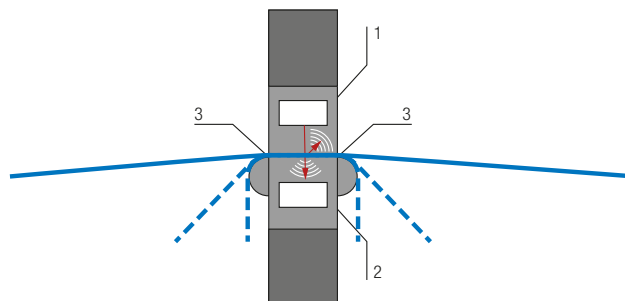

Legend

- 1 Transmitter
- 2 Receiver
- 3 Support rollers
- 4 Area of the basis weight measurement
- OW Operating width
- NW Nominal width

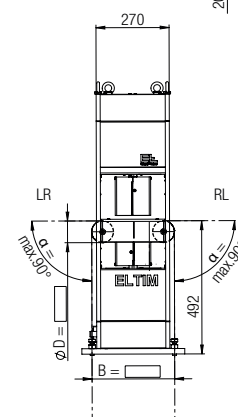
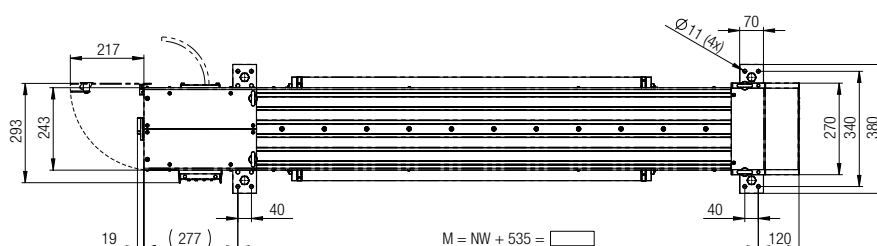
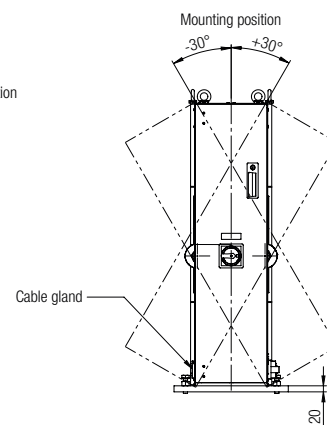
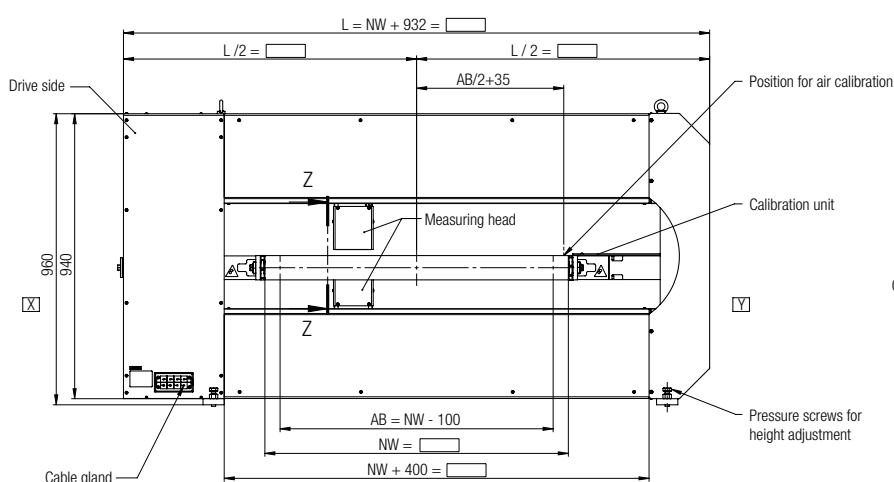
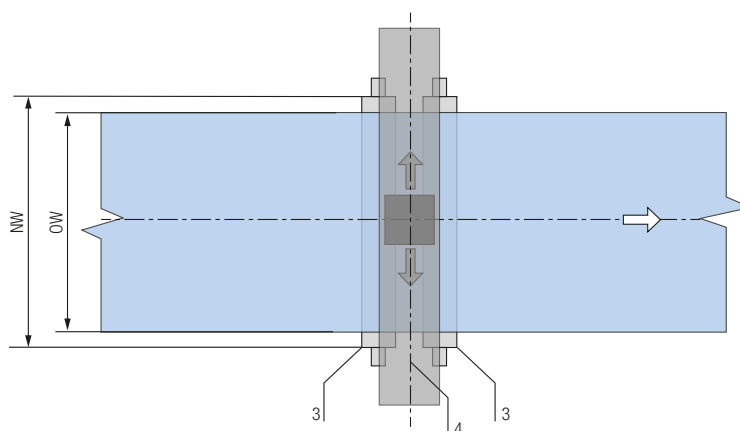

ELTIM BWS15/17 C-frame

- Space-saving and easy to integrate: ideal for systems with limited installation space or access from one side – also during retrofitting.
- Flexible use: optionally available on linear guide with motor drive – for basis measurements over the entire travel.
- Improved accessibility: design open on one side – for straightforward operation, cleaning and visual checks.
- Versatile – inline or offline: also available as stand-alone version for laboratory environments – ideal for development, quality assurance or sample inspection.
- Robust and maintenance-free: durable, reliable and without mechanical maintenance effort – for maximum availability.
- ATEX – EU directive on explosion protection: ELTIM systems will in future also be available in a special version for explosion hazard areas. Ex zones and version on request.
- Identification of coated surfaces via contrast sensors (for intermittent coating on top or underside)
- Same spot measurement for highly accurate determination of the basis weights of coatings, for example

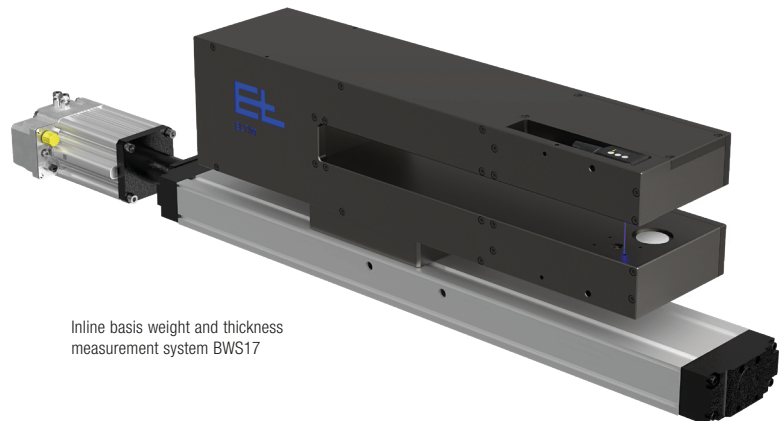

Inline basis weight and thickness measurement system BWS17

General functions

Measurement of the basis weight (current, average, min. & max., basis weight profile over the entire width)

Comparison of nominal and measured values

Tolerances Tolerances for warning and alarm if target exceeded or dropped below

Data output To PLC, to ELQ, to I/O

User levels/pass-word Operator level: Limited access rights Engineer level: Full access rights

WBM interface Web-based administration Configuration and value display accessible via web browser

Technical data

Measuring range (basis weight measurement)	Up to 4000 g/m ²
Measuring accuracy	< ±0.5 % of the basis weight of the calibration piece
Resolution	0.001 g/m ²
Sensor type	US ultrasonic sensor
Measuring point size	Ø 25 mm
Cycle time of the measuring system	120 Hz
Passage height	40 mm (from measuring head to measuring head)
Height fluctuation of the web	±5 mm in the middle; no fluttering
Max. actuating speed (only for variants with crossbeam)	150 mm/s
Relative humidity	max. 95 % (non-condensing)
Ambient temperature	+10 °C to +50 °C
Ambient temperature at the sensor	+10 °C to +70 °C
Storage temperature	-20 °C to +80 °C
Certification (optional)	UL/CSA
Operating voltage	24 V DC, 4 A (10 A for variant with crossbeam)
Nominal width (NW)	130 mm (5") to 610 mm (24") (larger widths on request)
Dimensions	L (NW + 228 mm) x H 144 mm x D 140 mm

Compact and flexible

The ELTIM C-frame is an intelligent measuring system for the highly accurate determination of the basis weight and thickness of continuously moving fabric webs. The compact C-frame is available as a fixed unit or, optionally, installed on a crossbeam to make possible measurements at various positions on the web.

Thanks to its open design on one side, it impresses with its minimal installation dimensions, high flexibility and straightforward integration, whether for static inline measurements, as a traversing system or as a laboratory unit for individual measurements.

The ELTIM C-frame utilizes proven ultrasonic technology for the contactless and radiation-free measurement of the basis weight of e.g. plastic films, coatings, laminates and numerous other materials. It is ideal for static point measurements, but can also be used for traversing measurements in applications with limited installation space.

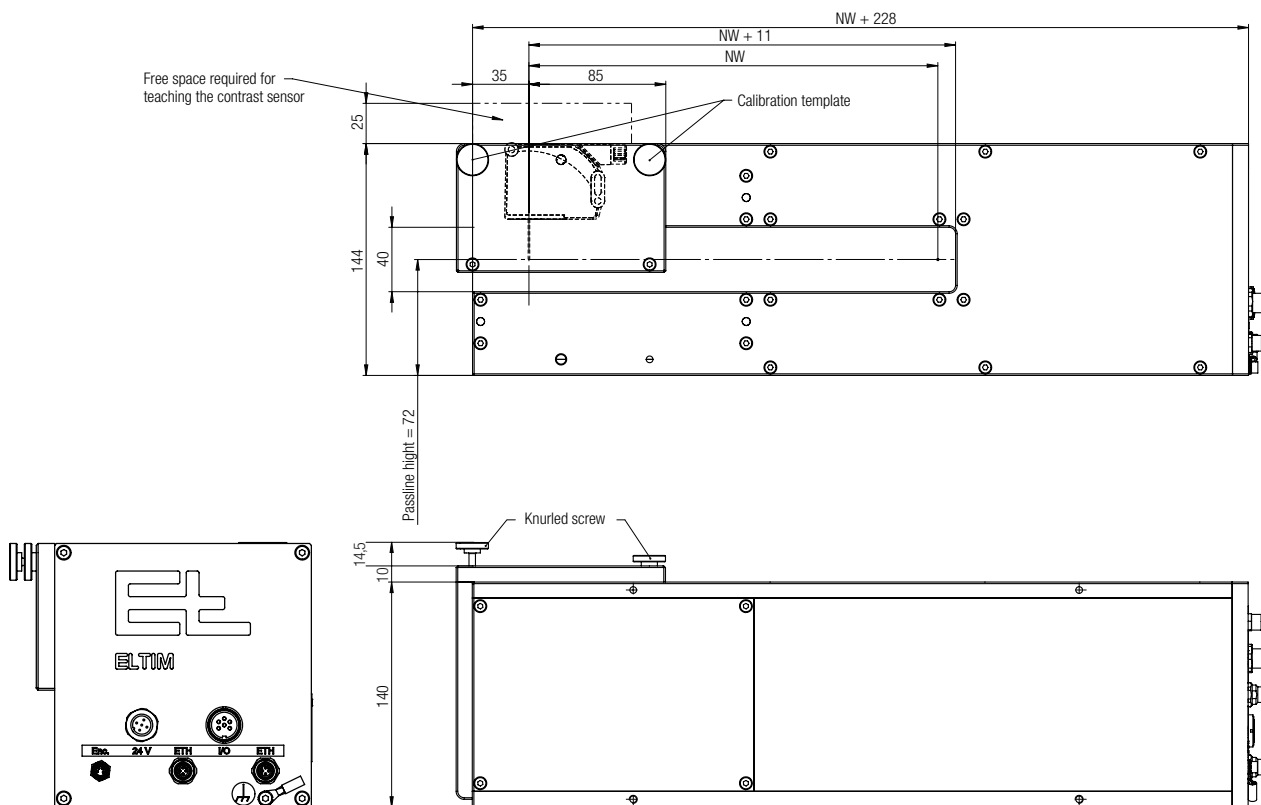

Control and data management software ELQ

Maximize the value of your knowledge

Our central ELQ software is designed for the operation and optimization of your E+L systems and handles data management for all production data, including data acquired from third-party systems via standard interfaces, for complete evaluation, analysis and documentation of your quality data.

The modular layout means that it is possible to connect a wide range of different systems and sensors, whether thickness measurement systems with confocal, interferometric, or laser triangulation sensors, basis weight measurement systems, closed-loop control systems based on the new EL.NET technology, or web tension measurement systems. All the data are displayed in a dashboard on the user-friendly panel PC with touchscreen. The hard drive is sufficient to store up to one year of archive data. Older data can also be deleted automatically.

- Statistical evaluation (maximum and minimum values, standard deviation, Cp, Cpk, etc.)
- Verification of measuring equipment capability by means of automated MSA test
- Automatic order/reel logs in the archive
- Central recipe management
- Operating and optimizing
- Various customer interfaces (Ethernet IP/UDP, Profinet, SQL, OPC-UA, and many more)
- Reel logs in PDF format
- Export of the measured data for a reel in CSV format
- Database interface possible
- Interface to MES (Manufacturing Execution System) possible
- High level of customization of the dashboard due to extended views

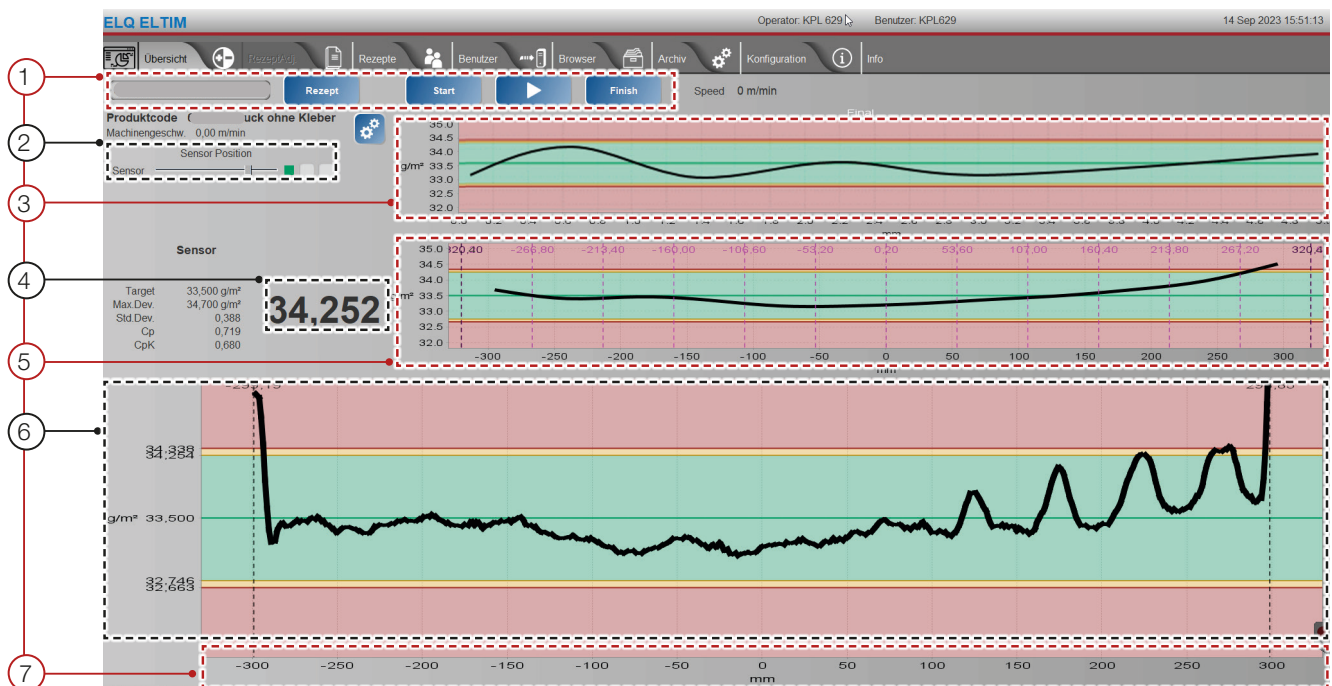

Legend

- 1 Manual operation
- 2 Relative sensor position
- 3 Measured value trend in direction of web travel (MD scan)
- 4 Numerical display of the current measured value
- 5 Profile of the mean values for measuring ranges transverse to the direction of web travel
- 6 Raw profile for measuring ranges transverse to the direction of web travel (CD scan)
- 7 Web width

Freely adjustable measuring ranges

- Alarm range (high grammage)
- Warning range (high grammage)
- Tolerance range (high grammage)
- Target weight
- Tolerance range (low grammage)
- Warning range (low grammage)
- Alarm range (low grammage)

Reports

The ELQ software allows you to output your measurement data quickly and easily as a PDF or CSV. PDF files provide clear, concise documentation for internal quality assurance, audits and customer reports. CSV files permit uncomplicated further processing of the data for deeper analysis and integration in your own (MES) systems. In this way, you can ensure quality, create transparency and sustainably optimize your production process.

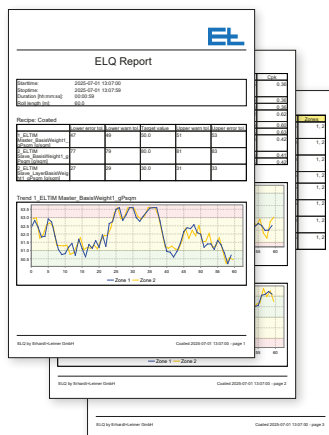

ELQ report in PDF format

CSV REPORT					
Start time [yyyy-MM-dd'T'HH:mm:ss.SSS]	Stop time [yyyy-MM-dd'T'HH:mm:ss.SSS]	Reference name	Target value [mm]	Upper tolerance [mm]	Lower tolerance [mm]
2020-07-31T15:03:01.775	2020-07-31T15:04:01.7	Thickness1	4	0.500	0.5

Timestamp [yyyy-MM-dd'T'HH:mm:ss.SSS]	Zone	K-position [mm]	Runlength [m]	Measuring Value
2020-07-31T15:03:01.775	0	50	0	3.992
2020-07-31T15:03:01.775	0	150	1	4.020
2020-07-31T15:03:01.775	0	250	2	4.064
2020-07-31T15:03:01.775	0	350	3	3.993
2020-07-31T15:03:01.775	0	450	4	3.996
2020-07-31T15:03:02.725	0	50	5	4.025
2020-07-31T15:03:02.725	0	150	6	4.063
2020-07-31T15:03:02.725	0	250	7	3.983
2020-07-31T15:03:02.725	0	350	8	4.024
2020-07-31T15:03:02.725	0	450	9	4.106
2020-07-31T15:03:03.729	0	50	10	4.003
2020-07-31T15:03:03.729	0	150	11	3.928
2020-07-31T15:03:03.729	0	250	12	3.959
2020-07-31T15:03:03.729	0	350	13	4.039

ELQ report in CSV format

Measuring System Analysis (MSA)

An automated MSA investigation means that the testing of the measuring equipment capability is very straightforward and easy to perform.

Cg and Cgk values are calculated based on the standard deviation of the measurement values and systematic measurement deviation.

Min value	425.83 g/m ²
Average value	426.10 g/m ²
Max value	426.30 g/m ²
Standard deviation	0.0992
cg	4.2966
cgk	4.2912

MSA statistics

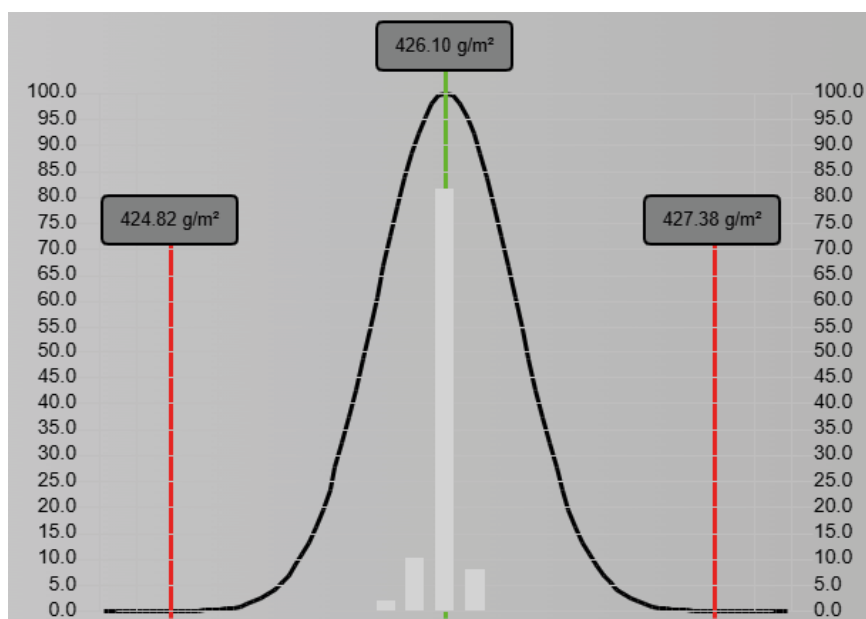

Distribution of the measurement values

	Value
0	426.018
1	426.242
2	426.082
3	426.091
4	426.052
5	426.027
6	426.237
7	426.085
8	426.142

Table with measured results

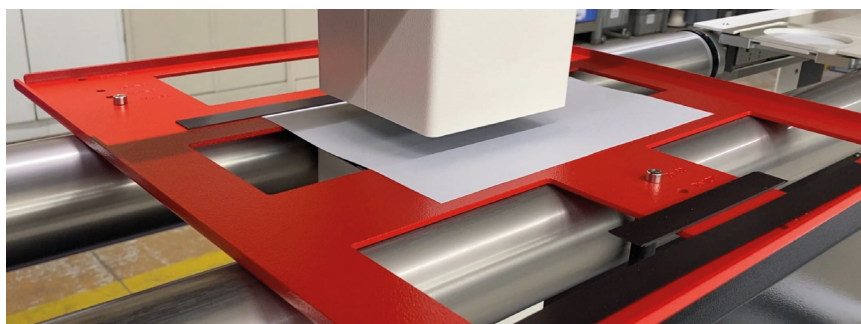

Measuring frame for MSA tests or measurements of material samples (optional)

Expansion options



Signal lamp



OP 9023 operating panel with touch function 15.6" FullHD



Touchpanel with pivoting arm



OP 9035 wheeled operating panel

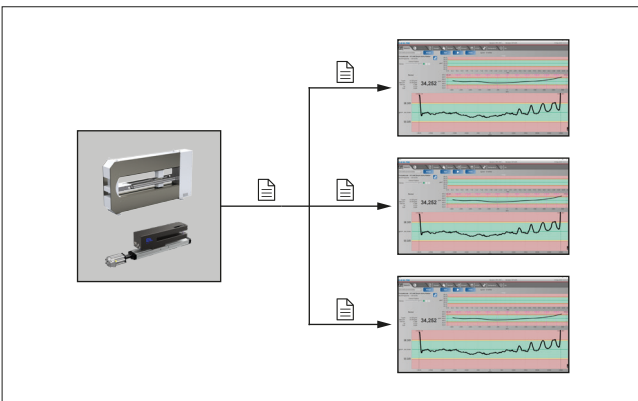

Multiple ELQ screens possible (server/client architecture)

- Control functions (closed loop) on request (e.g. slotted nozzle regulation)
- Automatic adjustment of the travel based on the material edges detected
- Air conditioning as overheating protection and to extend service life
- Material sample set



ATEX

A special version of the ELTIM O-frame systems can also be used in EX zone 1. ELTIM C-frame systems can be certified on request.

Lane and pattern detection

By using a contrast sensor, coated surfaces can be reliably identified even with intermittent coating on the underside or top of the material.

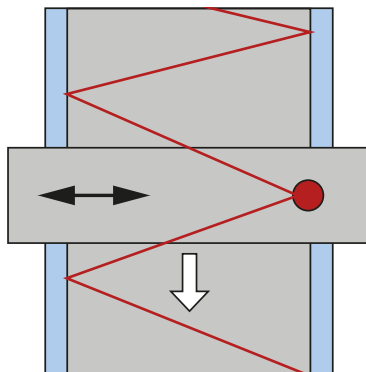

Traversing system for full-surface coating or uncoated material

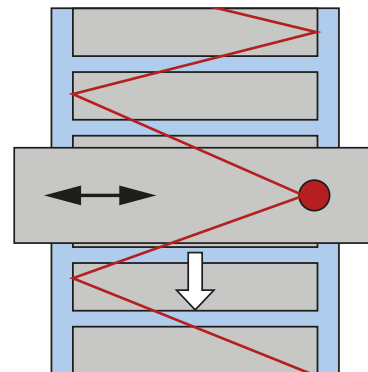

Traversing system for transversely intermittent coating transverse to the direction of web travel

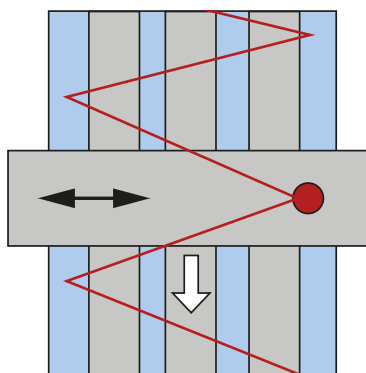

Traversing system for longitudinally intermittent coating in the direction of web travel

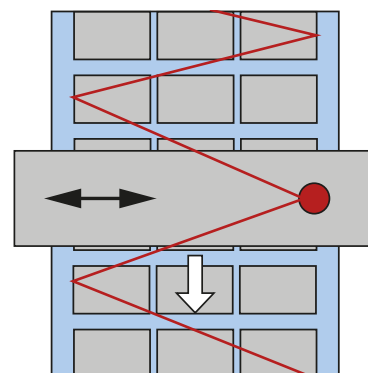

Traversing system for segmented matrix coating in the direction of web travel and transverse to the direction of web travel

Same spot measurement

Two or more measuring frames (O- or C-frame) measure the basis weight of a material before and after a process step. Here measuring points at exactly the same position on the same

measuring line are measured before and after the process step. In this way the differential surface weight, e.g. of the coating, can be determined with high precision.

Differential basis weight = basis weight ELTIM 2 - basis weight ELTIM 1

Legend

- Measuring line ELTIM 1
- Measuring line ELTIM 2

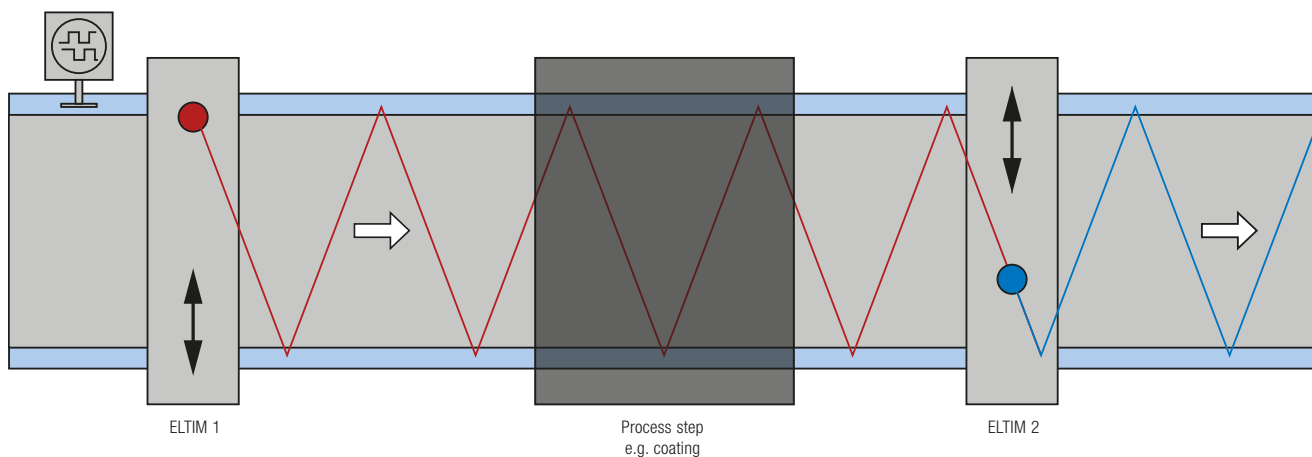

Application examples

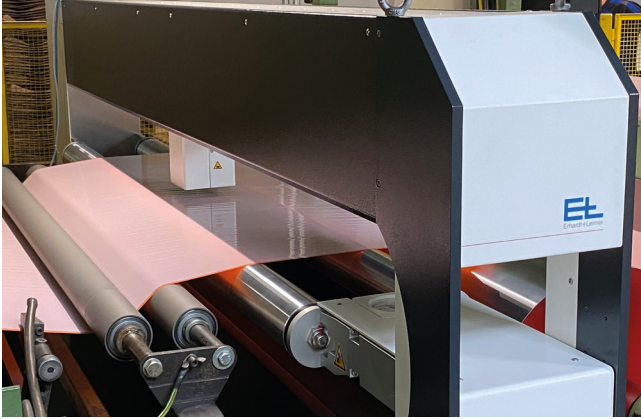

Film coating (adhesive tapes)



Film production (extrusion)

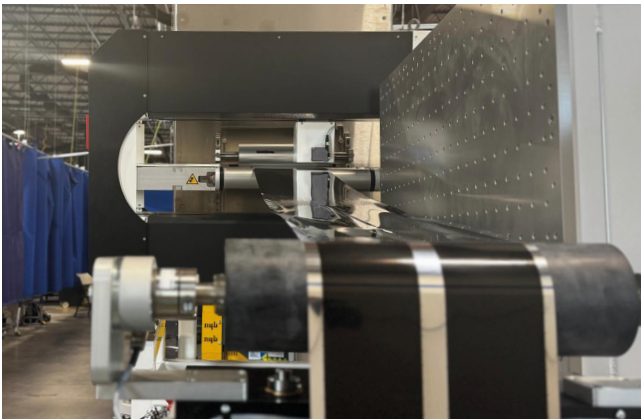

Battery production

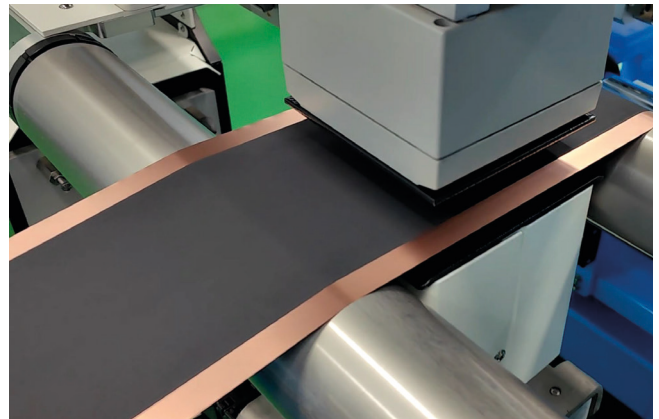

Battery production

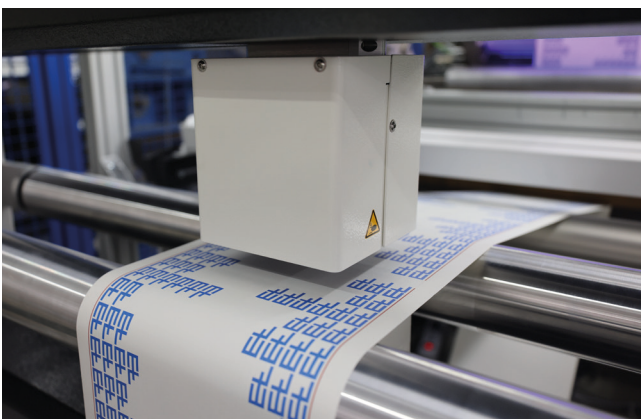

Film manufacture (printed film)

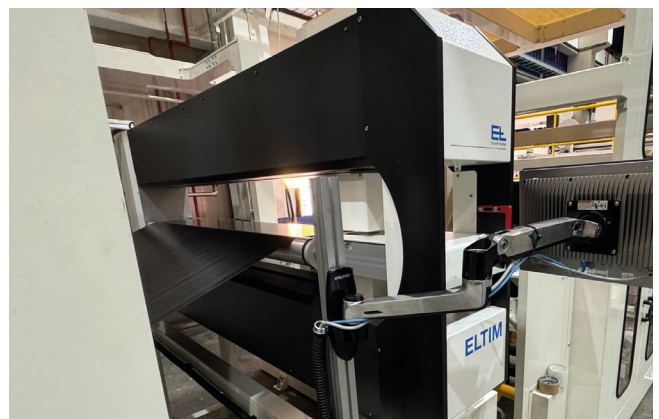

Manufacture of PVC film (calender)

Application example: detecting delamination

Invisible defects – appreciable consequences

Even minimal fluctuations in the application of the adhesive or in the material thickness can cause hidden delamination. Material irregularities and uneven adhesive distribution during production lead to invisible defects in the substrate, sometimes with serious consequences:

- unstable products
- increased risk of complaints
- avoidable costs

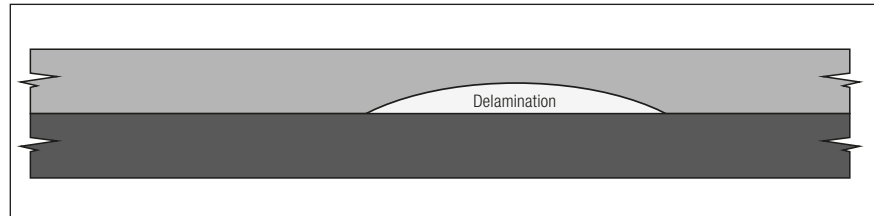

Not visibly apparent - measurable with ELTIM

The solution – ELTIM makes the invisible visible

During normal operation, the ELTIM system provides precise data about the basis weight. If ELTIM detects a delamination zone in the process, the intelligent software analyzes the anomaly and reacts immediately:

- with a visual or audible alarm
- by marking the exact position for subsequent analysis
- by documenting automatically for quality verification

In this way, not only is the quality of your products checked, it is also assured.

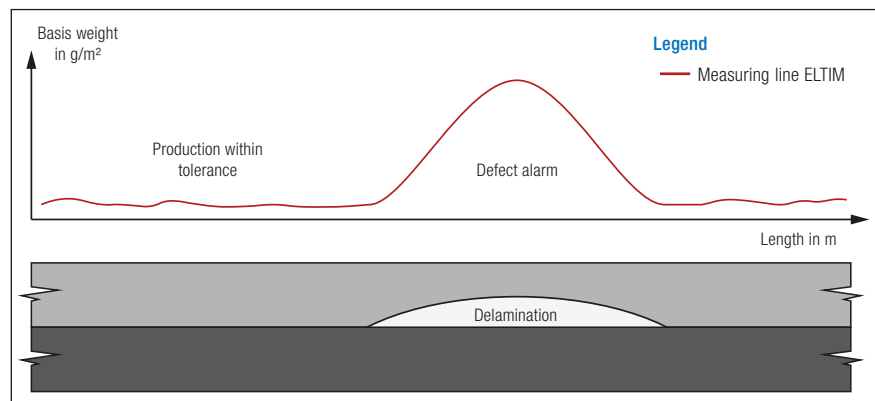

The measuring curve shows clearly: stable values in normal operation – abrupt peaks if delamination occurs

ROI with ELTIM – three steps to efficiency

1. Reliable measuring equipment capability

By means of an integrated MSA test, the measuring equipment capability of the ELTIM system is verified and documented before production start. Additional laboratory tests are not required and production can start immediately.

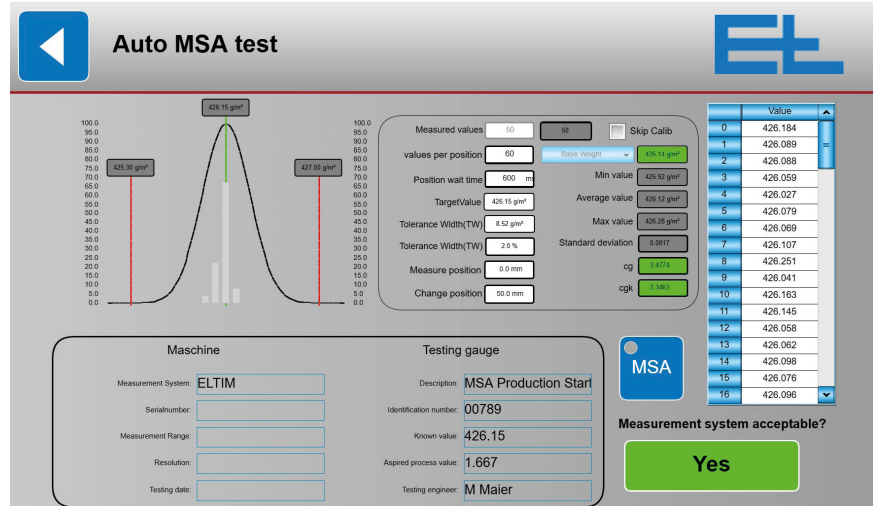

2. Less downtime - more output

With ELTIM it is not necessary to stop the machine for manual sampling and tedious offline measurements. Production runs from start-up to steady-state operation – continuously monitored and without downtimes.

The result:

- significant time savings
- faster start-up processes
- greater utilization
- more output
- noticeably more efficient production

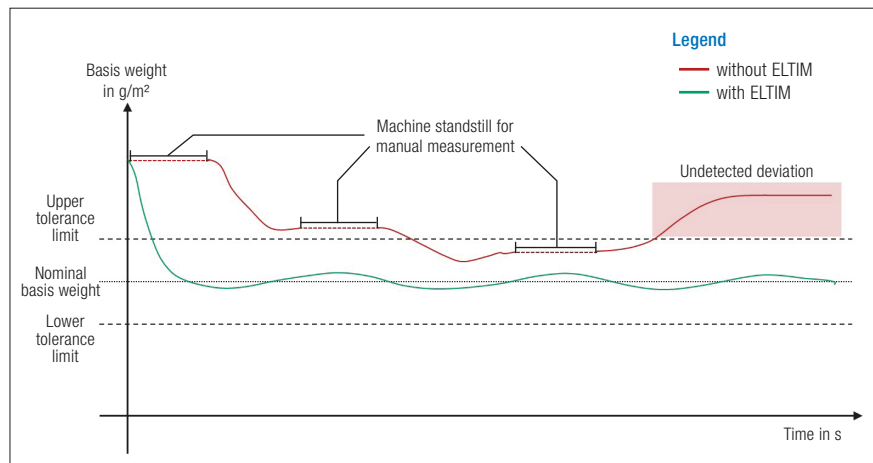

3. Stable processes - constant quality

With ELTIM, the basis weight is monitored continuously and precisely controlled – manually or fully automatically. Even manual control by the operator significantly reduces the deviations compared to processes without ELTIM. Automatic closed-loop control brings additional precision and maximum process reliability, while during production without ELTIM, undetected tolerance deviations and therefore scrap can occur that is only detected if remeasured.

The result with ELTIM:

- less scrap
- smaller deviations and therefore closer tolerances
- greater product quality

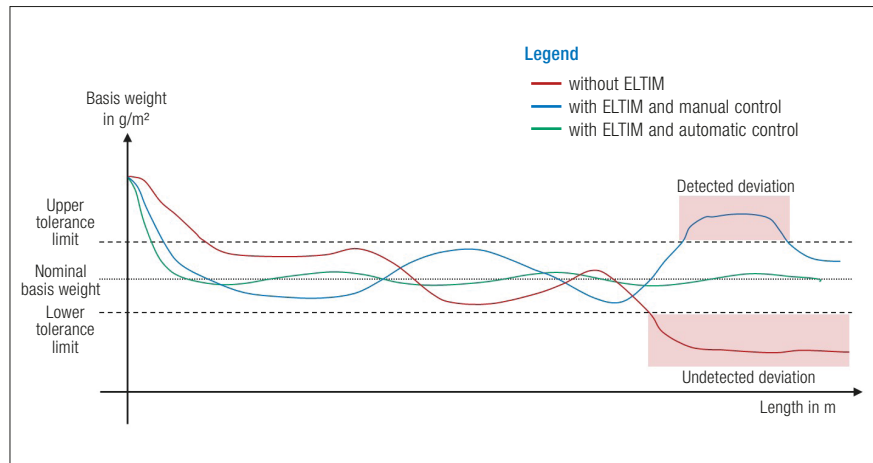

Sample examination with customer material

Individual material examination

Erhardt+Leimer offers a free, no-obligation sample examination during which a feasibility study is created. This report guarantees the efficiency of the basis weight measurement in the existing production process. Constant quality control of the material by ELTIM actively and sustainably contributes to resource optimization.

Requirements for sample examination

- Fully filled-in questionnaire (see page 18/19)
- Sample goods with the material to be examined
- **Two samples per material**
- **Format: DIN A4**

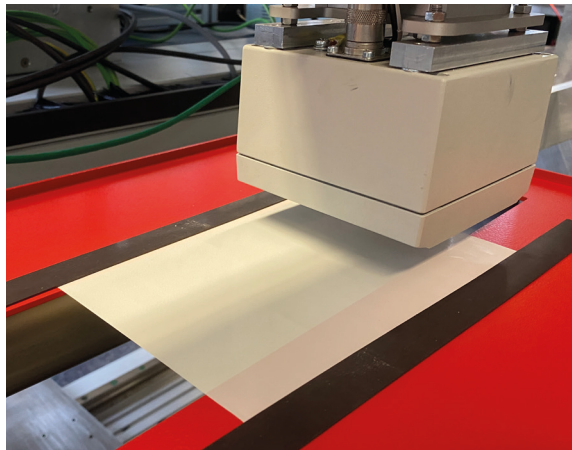

Measurement of a fabric web

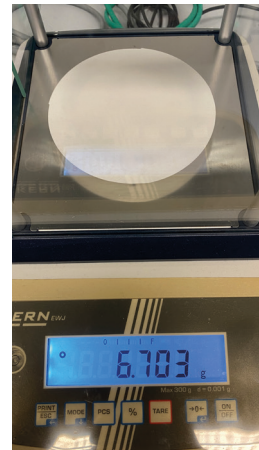

Reference measurement using a precision scale

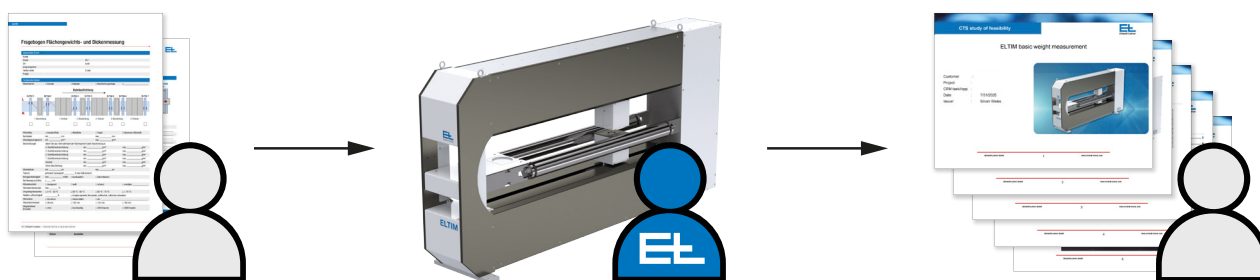

Your ROI with ELTIM

- Less scrap during production start
- Continuous quality assurance without interrupting production and therefore no undetected waste during production
- Automatic control reduces tolerances and saves material
- Greater machine utilization due to stable processes

Questionnaire basis weight and thickness measurement

General data

Customer

Street

Zip code

City/town

Country

Contact person

Phone (direct)

E-mail

Project

Technical data

Type of machine

 Extruder Calender Coating system _____

Direction of web travel

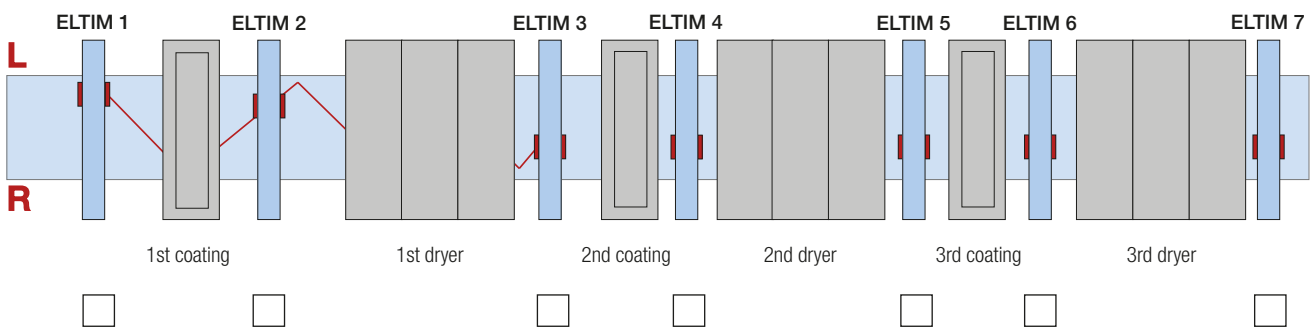

Material type

 Plastic film Metal foil Paper Non-woven fabric

Web width

min. _____ mm

max. _____ mm

Total material weight

min. _____ g/m²max. _____ g/m²

Coatings

State the minimum/maximum basis weight of each coating

4th surface coating

min. _____ g/m²max. _____ g/m²

3rd surface coating

min. _____ g/m²max. _____ g/m²

2nd surface coating

min. _____ g/m²max. _____ g/m²

1st surface coating

min. _____ g/m²max. _____ g/m²

Substrate

min. _____ g/m²max. _____ g/m²

Lower coating

min. _____ g/m²max. _____ g/m²

Material thickness

min. _____ μm

max. _____ μm

Tolerance

Required accuracy _____ % of the calibration value

Web speed

max. _____ m/min.

 Continuous Intermittent

Web movement (height)

± _____ mm

Material variation

 Transparent White Black Other _____

Fabric web temperature

max. _____ °C

Ambient temperature

 0 °C to 50 °C 50 °C to 60 °C 60 °C to 70 °C > 70 °C

Relative humidity

_____ %

 Ambient values (temperature, atmospheric humidity, air pressure) fluctuate

Support rollers

 Aluminum Hard anodized etc.:

Roller diameter

 80 mm 100 mm 120 mm 160 mm

Encoder

 Without Customer 2000 pulses 5000 pulses

Technical data

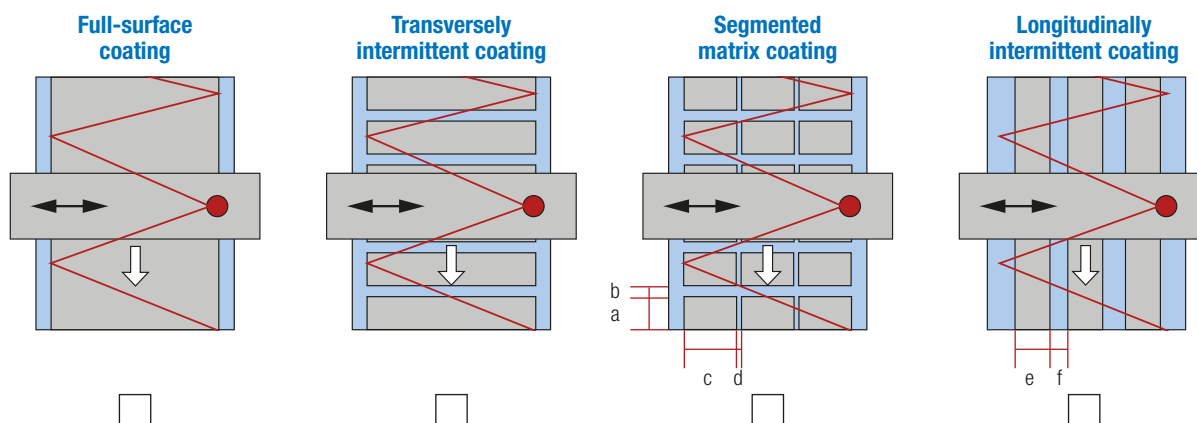

Are the top and bottom coating identical?

Yes

No

With segmented matrix coating

Number of segments transverse to the web _____

Dimension a in mm min. _____ max. _____

Dimension b in mm min. _____ max. _____

Dimension c in mm min. _____ max. _____

Dimension d in mm min. _____ max. _____

With longitudinally intermittent coating

Number of longitudinally intermittent coatings _____

Dimension e in mm min. _____ max. _____

Dimension f in mm min. _____ max. _____

Control unit Customer OP 90 Terminal Built-in panel PC 21.5"

Cable length, system power supply Without 3 m 5 m 10 m 15 m 25 m

Cable length, control unit power supply Without 3 m 5 m 10 m 15 m 25 m

Cable length, Ethernet, control unit <-> system Without 3 m 5 m 10 m 15 m 25 m

Cable length, position encoder Without 3 m 5 m 10 m 15 m 25 m

Selection of the calibration side/operating side L R

MSA measuring frame Without With

Same spot measurement required Yes No

Same spot measurement required between ELTIM systems
 1 and 2 2 and 3 3 and 4 4 and 5 5 and 6 6 and 7

Machine interface desired Digital I/O Others (e.g. PLC) _____

Is a closed control loop required? Yes No Description _____

ELTIM system number 1 2 3 4 5 6 7

No Ex protection

Ex protection zone 1

Comments

Date

Issuer

Head office

Erhardt+Leimer GmbH
Albert-Leimer-Platz 1 · 86391 Stadtbergen, Germany
Phone: +49 (0)821 2435-0
info@erhardt-leimer.com · www.erhardt-leimer.com



Subsidiaries

E+L Elektroanlagen Augsburg, Germany · E+L Steuerungstechnik St. Egidien, Germany
E+L Bradford, England · E+L Mulhouse, France · E+L Stezzano, Italy · E+L Bucharest, Romania
E+L Barcelona, Spain · E+L Burlington, Canada · E+L Duncan, S.C., USA · E+L Guarulhos-São Paulo, Brazil
E+L Ahmedabad, India · E+L Hangzhou, China · E+L Tao Yuan, Taiwan Province · E+L Yokohama, Japan
E+L Seoul, Republic of Korea · E+L Bangkok, Thailand



Subject to technical change without notice · PRO--251261-EN-08 · 09/2025 · 374432