

# PARALLEL GRIPPERS WITH T-GUIDE

## SERIES CGPT

SINGLE AND DOUBLE ACTING, MAGNETIC, SELF-CENTERING  
SIZES: Ø16, 20, 25, 32, 40, 50, 63, 80 MM



Thanks to the use of a high performing and precise force transmission system, the Series CGPT grippers are able to provide high gripping forces while guaranteeing a very high repeatability.

The wide range of sizes available allows you to find the best solution for any need of movement. The grippers are supplied with centering bushes (tolerance H8) which, once positioned on the body and/or on the jaws, are able to guarantee, during maintenance, a high interchangeability of the gripper and of the extensions.

- Robust, compact and light design
- High closing/opening forces
- Fixing from the top, from below and from the side
- Supply on the side or on the bottom (even without using tubes)
- Self-centering jaws
- High closing and opening repeatability
- High interchangeability (centering bushes)
- Position detection thanks to the use of magnetic proximity switches
- In compliance with ROHS directive
- PTFE, Silicone and Copper free
- High reliability
- High resistance to external loads thanks to the T-guide
- Variants available for use in ATEX zones and for high temperatures

### GENERAL DATA

<b>Type of construction</b>	Self-centering parallel gripper with T-guide
<b>Operation</b>	Single acting (NO, NC), double acting
<b>Sizes</b>	Ø16, 20, 25, 32, 40, 50, 63, 80 mm
<b>Force transmission</b>	Lever
<b>Air connections</b>	M3 (Ø16), M5 (Ø20, 25, 32), G1/8 (Ø40, 50, 63, 80)
<b>Working pressure</b>	2 ÷ 8 bar (double acting), 4 ÷ 8 bar (single acting)
<b>Working temperature</b>	5°C ÷ 60°C (standard) - 5°C ÷ 130°C (high temperature version)
<b>Store temperature</b>	-10°C ÷ 80°C
<b>Maximum use frequency</b>	3 Hz (Ø 16, 20, 25, 32), 2 Hz (Ø 40, 50, 63, 80)
<b>Repeatability</b>	0.02 mm
<b>Interchangeability</b>	0.1 mm
<b>Medium</b>	Filtered air in class 7.4.4 according to ISO 8573-1. In case lubricated air is used, we recommend ISOVG32 oil and to never interrupt lubrication.
<b>Lubrication</b>	After 10 million cycles, grease the sliding zones using Molykote DX grease.
<b>Protection class</b>	IP 40
<b>Compatibility</b>	ROHS Directive
<b>Certifications</b>	ATEX (II 2GD c IIC 120°C(T4)-20°C≤Ta≤80)
<b>Materials</b>	PTFE, Silicone and Copper free

N.B. Pressurize the pneumatic system gradually in order to avoid uncontrolled movements

**Coding example**

<b>CGPT</b>	-	<b>16</b>	-	<b>NC</b>	-	<b>W</b>	<b>EX</b>
<b>CGPT</b>	SERIES						
<b>16</b>	SIZES 16 20 25 32 40 50 63 80						
<b>NC</b>	FUNCTIONING = double acting NO = single acting, normally open NC = single acting, normally closed					<b>PNEUMATIC SYMBOLS</b> PNZ1 PNZ3 PNZ2	
<b>W</b>	VERSION = standard W = high temperatures (130 °C) - not magnetic						
<b>EX</b>	Add EX to order the certified ATEX version						

GRIPPERS

3

**Pneumatic symbols**

The pneumatic symbols which have been indicated in the CODING EXAMPLE are shown below.

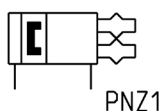

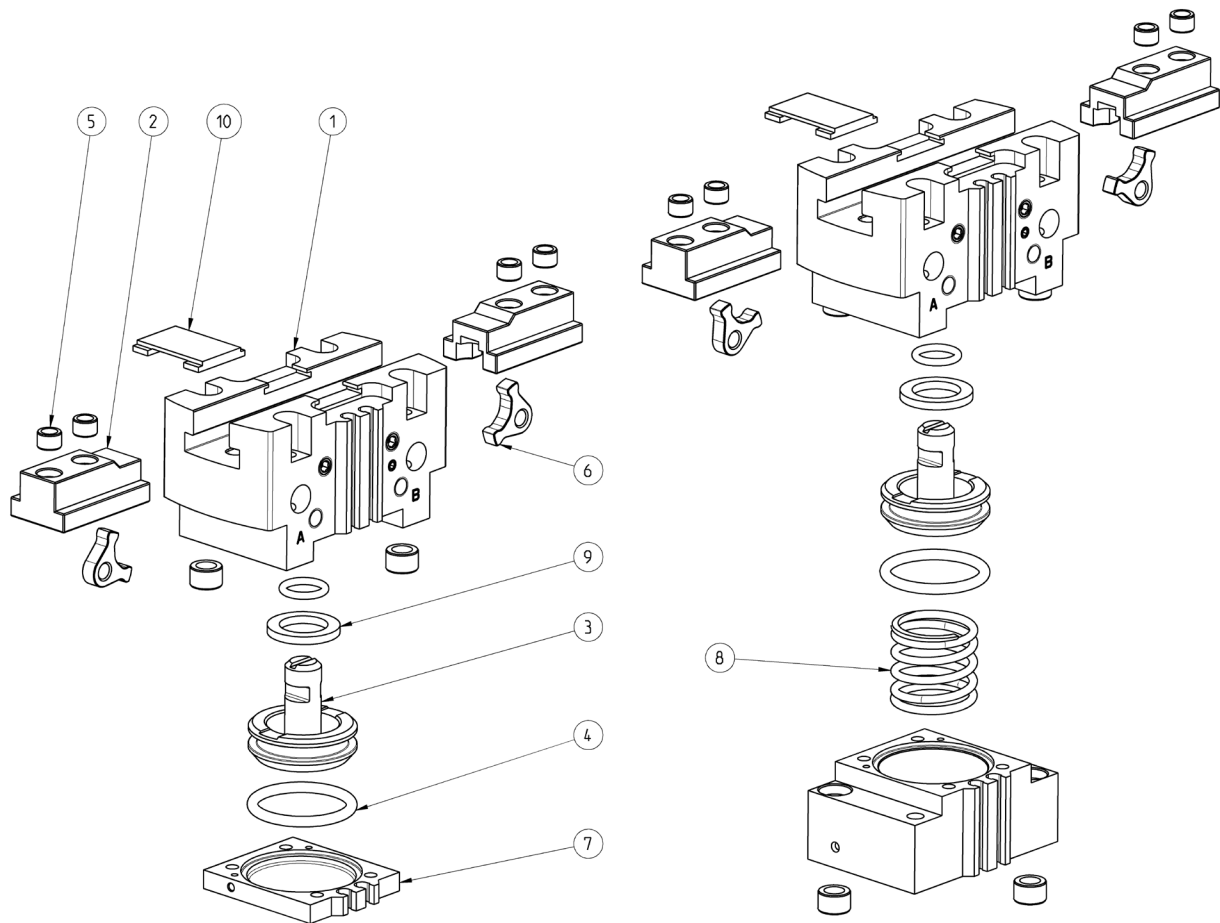
**Series CGPT grippers - construction**

PARTS	MATERIALS
1 - Body	Aluminium
2 - Guide	Stainless steel
3 - Cursor	Stainless steel
4 - Piston	HNBR / FKM
5 - Jaw	Stainless steel
6 - Cover	Steel
7 - Spring	Aluminium / Stainless steel
8 - Magnete	Stainless steel
9 - Screws	Neodymium
10 - Seals	Stainless steel

**PARALLEL GRIPPERS WITH T-GUIDE**  
**SERIES CGPT - DIMENSIONAL CHARACTERISTICS**
**Gripper - size 16 mm**

GRIPPERS

3

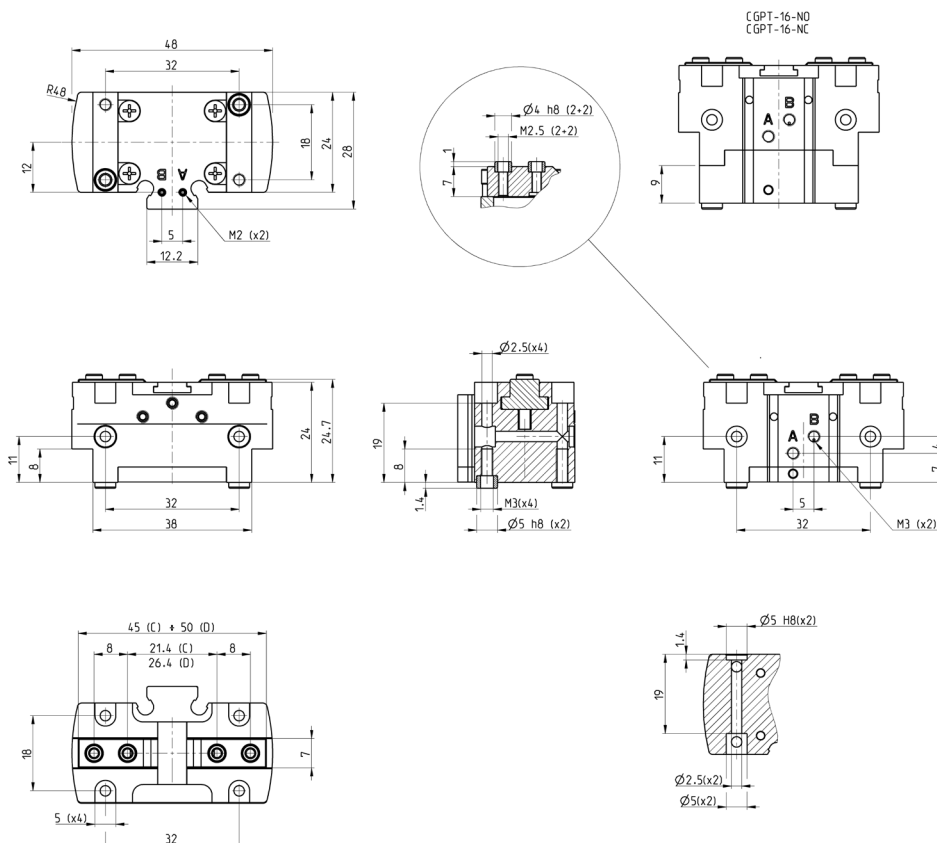

**DRAWING LEGEND:**

- A = Opening of air connection
- B = Closing of air connection
- C = Closed gripper
- D = Open gripper

Mod.	Total closing gripping force at 6 bar (N)	Closing gripping force each jaw at 6 bar (N)	Total opening gripping force at 6 bar (N)	Opening gripping force each jaw at 6 bar (N)	Stroke per jaw (mm)	Working pressure (bar)	Working temperature (°C)	Repeatability (mm)	Max use frequency (Hz)	Weight (kg)
CGPT-16	114	57	130	65	2,5	2 ÷ 8	5 ÷ 60	0,02	3	0,09
CGPT-16-NC	152	76	84	42	2,5	4 ÷ 8	5 ÷ 60	0,02	3	0,11
CGPT-16-NO	70	35	166	83	2,5	4 ÷ 8	5 ÷ 60	0,02	3	0,1

PARALLEL GRIPPERS WITH T-GUIDE  
**SERIES CGPT - DIMENSIONAL CHARACTERISTICS**

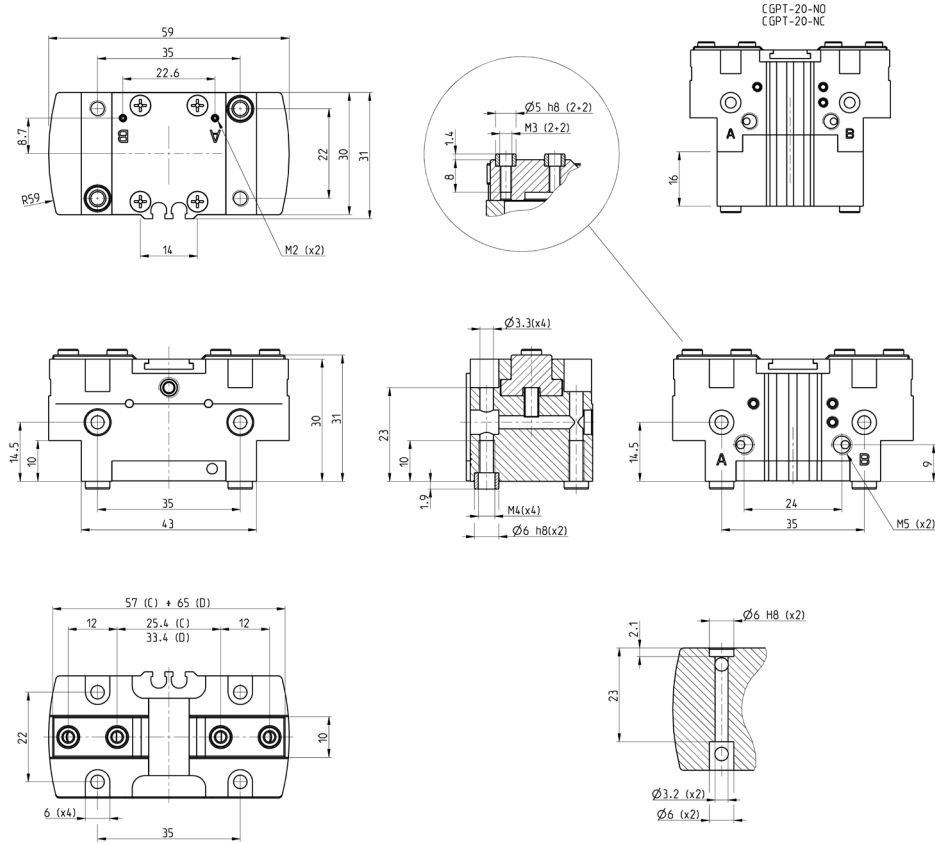
Gripper - size 20 mm



**DRAWING LEGEND:**  
**A** = Opening of air connection  
**B** = Closing of air connection  
**C** = Closed gripper  
**D** = Open gripper

Mod.	Total closing gripping force at 6 bar (N)	Closing gripping force each jaw at 6 bar (N)	Total opening gripping force at 6 bar (N)	Opening gripping force each jaw at 6 bar (N)	Stroke per jaw (mm)	Working pressure (bar)	Working temperature (°C)	Repeatability (mm)	Max use frequency (Hz)	Weight (kg)
CGPT-20	158	79	180	94	4	2 ÷ 8	5 ÷ 60	0,02	3	0,15
CGPT-20-NC	198	99	120	60	4	4 ÷ 8	5 ÷ 60	0,02	3	0,2
CGPT-20-NO	100	50	220	110	4	4 ÷ 8	5 ÷ 60	0,02	3	0,18

**PARALLEL GRIPPERS WITH T-GUIDE**  
**SERIES CGPT - DIMENSIONAL CHARACTERISTICS**
**Gripper - size 25 mm**

GRIPPERS

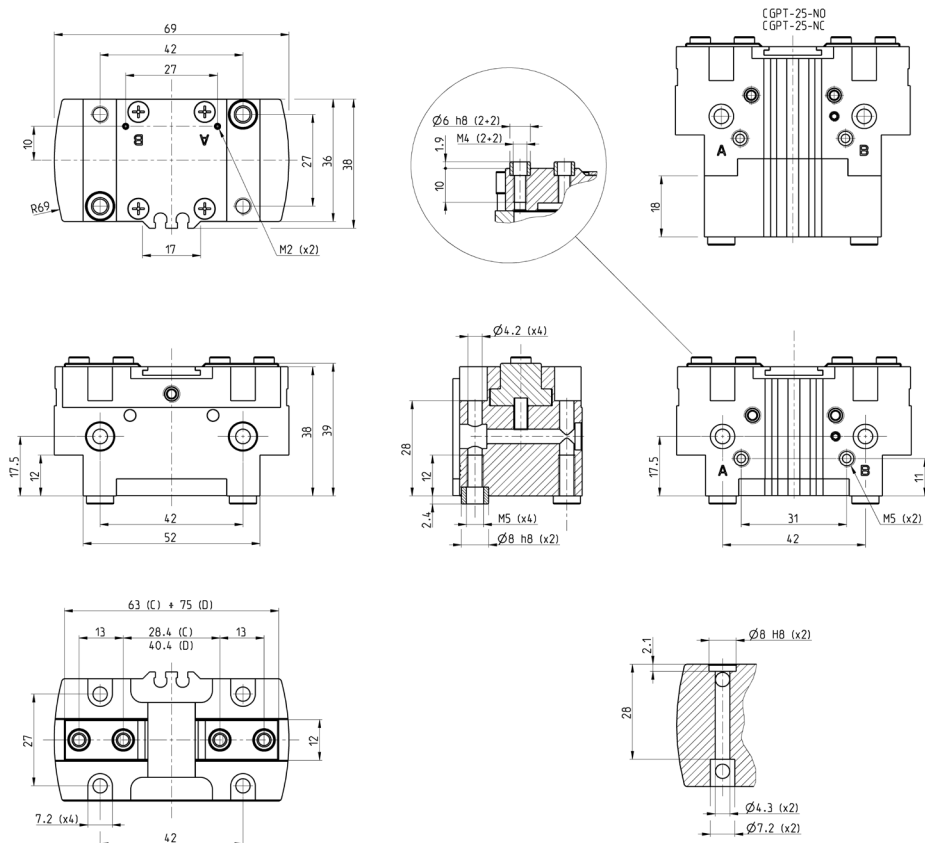
**3**

**DRAWING LEGEND:**

- A = Opening of air connection
- B = Closing of air connection
- C = Closed gripper
- D = Open gripper

Mod.	Total closing gripping force at 6 bar (N)	Closing gripping force each jaw at 6 bar (N)	Total opening gripping force at 6 bar (N)	Opening gripping force each jaw at 6 bar (N)	Stroke per jaw (mm)	Working pressure (bar)	Working temperature (°C)	Repeatability (mm)	Max use frequency (Hz)	Weight (kg)
CGPT-25	230	115	266	133	6	2 ÷ 8	5 ÷ 60	0,02	3	0,27
CGPT-25-NC	280	140	200	100	6	4 ÷ 8	5 ÷ 60	0,02	3	0,35
CGPT-25-NO	166	83	316	158	6	4 ÷ 8	5 ÷ 60	0,02	3	0,33

PARALLEL GRIPPERS WITH T-GUIDE  
**SERIES CGPT - DIMENSIONAL CHARACTERISTICS**

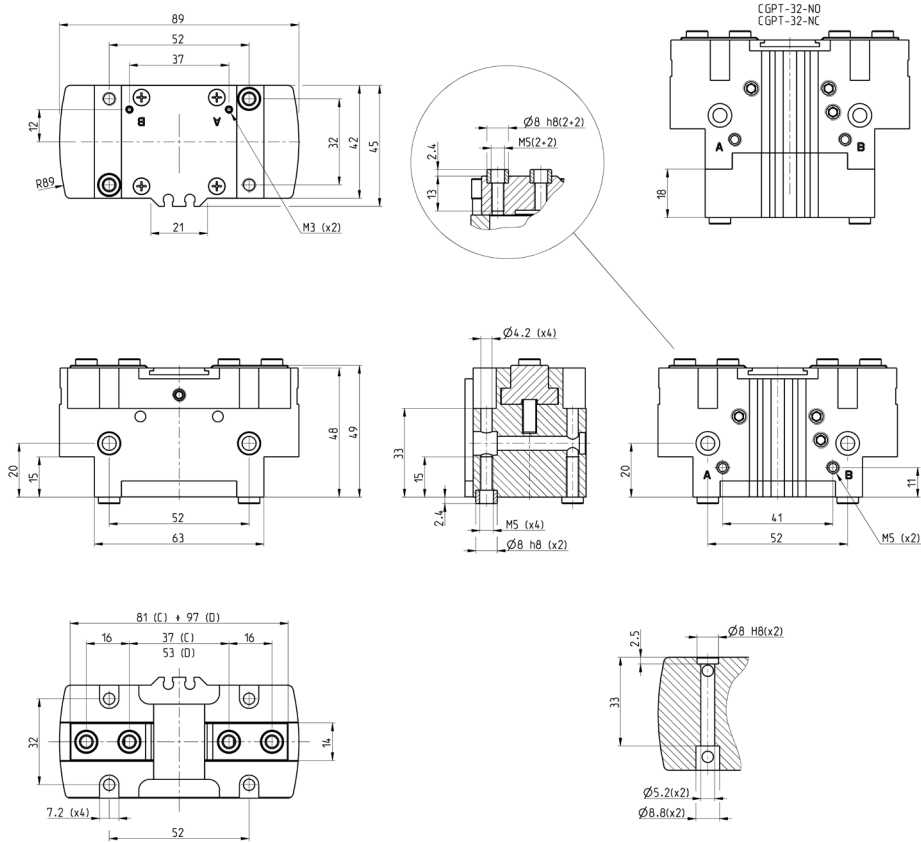
Gripper - size 32 mm



**DRAWING LEGEND:**  
**A = Opening of air connection**  
**B = Closing of air connection**  
**C = Closed gripper**  
**D = Open gripper**

Mod.	Total closing gripping force at 6 bar (N)	Closing gripping force each jaw at 6 bar (N)	Total opening gripping force at 6 bar (N)	Opening gripping force each jaw at 6 bar (N)	Stroke per jaw (mm)	Working pressure (bar)	Working temperature (°C)	Repeatability (mm)	Max use frequency (Hz)	Weight (kg)
CGPT-32	388	194	450	225	8	2 ÷ 8	5 ÷ 60	0,02	3	0,5
CGPT-32-NC	456	228	354	177	8	4 ÷ 8	5 ÷ 60	0,02	3	0,61
CGPT-32-NO	300	150	512	256	8	4 ÷ 8	5 ÷ 60	0,02	3	0,59

**PARALLEL GRIPPERS WITH T-GUIDE**  
**SERIES CGPT - DIMENSIONAL CHARACTERISTICS**
**Gripper - size 40 mm**

GRIPPERS

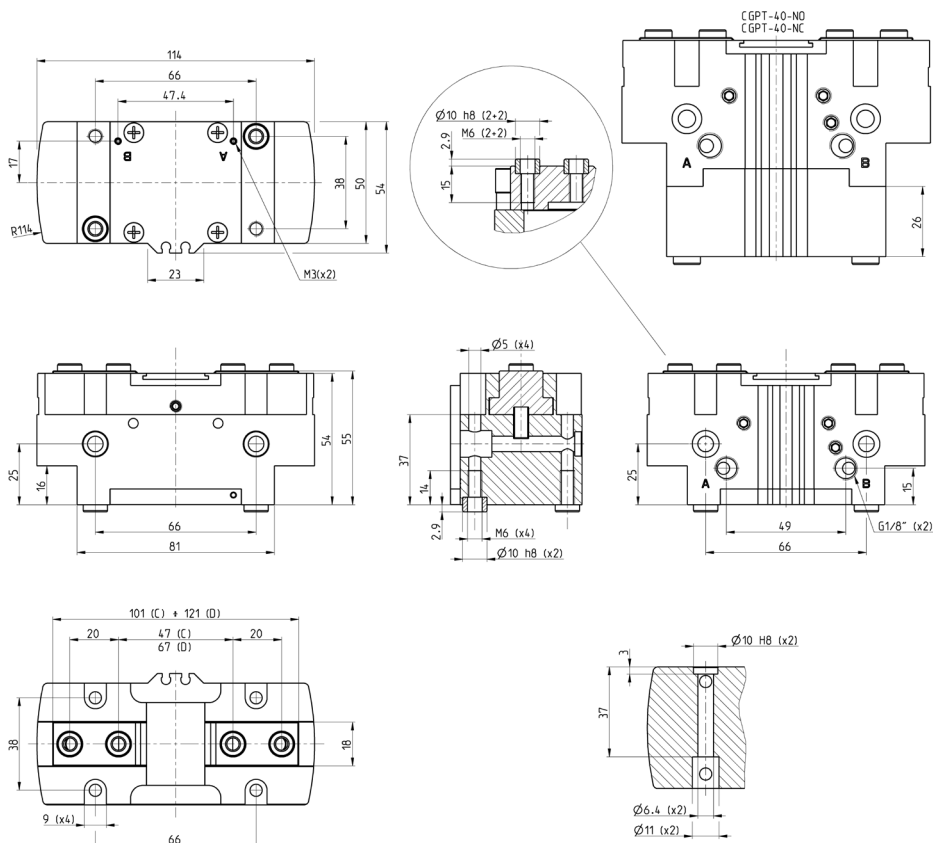
**3**

**DRAWING LEGEND:**

- A = Opening of air connection
- B = Closing of air connection
- C = Closed gripper
- D = Open gripper

Mod.	Total closing gripping force at 6 bar (N)	Closing gripping force each jaw at 6 bar (N)	Total opening gripping force at 6 bar (N)	Opening gripping force each jaw at 6 bar (N)	Stroke per jaw (mm)	Working pressure (bar)	Working temperature (°C)	Repeatability (mm)	Max use frequency (Hz)	Weight (kg)
CGPT-40	670	335	720	360	10	2 ÷ 8	5 ÷ 60	0,02	2	0,83
CGPT-40-NC	740	370	504	252	10	4 ÷ 8	5 ÷ 60	0,02	2	1,2
CGPT-40-NO	430	215	820	410	10	4 ÷ 8	5 ÷ 60	0,02	2	1,1



PARALLEL GRIPPERS WITH T-GUIDE  
**SERIES CGPT - DIMENSIONAL CHARACTERISTICS**

Gripper - size 50 mm

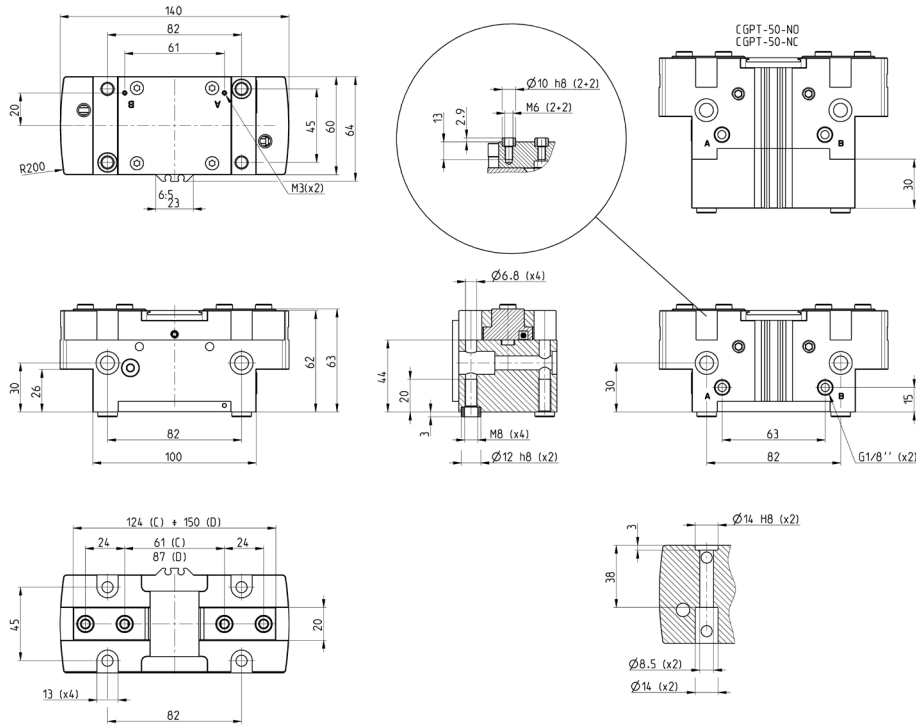

**DRAWING LEGEND:**  
**A** = Opening of air connection  
**B** = Closing of air connection  
**C** = Closed gripper  
**D** = Open gripper

Mod.	Total closing gripping force at 6 bar (N)	Closing gripping force each jaw at 6 bar (N)	Total opening gripping force at 6 bar (N)	Opening gripping force each jaw at 6 bar (N)	Stroke per jaw (mm)	Working pressure (bar)	Working temperature (°C)	Repeatability (mm)	Max use frequency (Hz)	Weight (kg)
CGPT-50	1044	522	1208	604	13	2 ÷ 8	5 ÷ 60	0,02	1	1,45
CGPT-50-NC	1380	690	778	389	13	4 ÷ 8	5 ÷ 60	0,02	1	1,72
CGPT-50-NO	642	321	1524	762	13	4 ÷ 8	5 ÷ 60	0,02	1	1,89

**PARALLEL GRIPPERS WITH T-GUIDE**  
**SERIES CGPT - DIMENSIONAL CHARACTERISTICS**
**Gripper - size 63 mm**

GRIPPERS

3

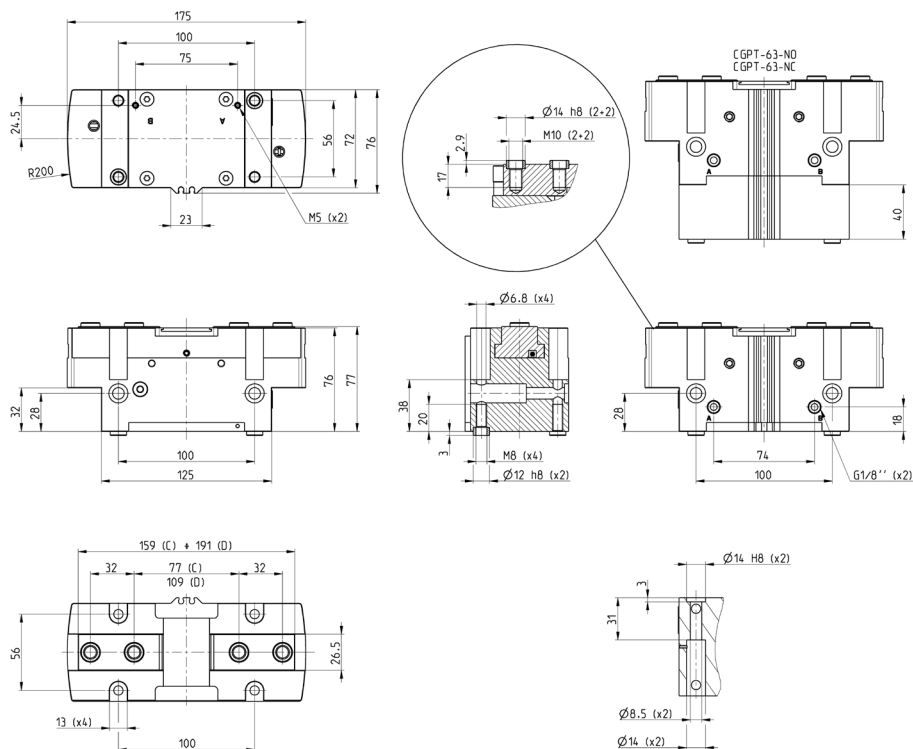

**DRAWING LEGEND:**

- A = Opening of air connection
- B = Closing of air connection
- C = Closed gripper
- D = Open gripper

Mod.	Total closing gripping force at 6 bar (N)	Closing gripping force each jaw at 6 bar (N)	Total opening gripping force at 6 bar (N)	Opening gripping force each jaw at 6 bar (N)	Stroke per jaw (mm)	Working pressure (bar)	Working temperature (°C)	Repeatability (mm)	Max use frequency (Hz)	Weight (kg)
CGPT-63	1486	743	1722	861	16	2 ÷ 8	5 ÷ 60	0.02	3	2,69
CGPT-63-NC	1910	955	1144	572	16	4 ÷ 8	5 ÷ 60	0.02	2	3,32
CGPT-63-NO	946	473	2108	1054	16	4 ÷ 8	5 ÷ 60	0.02	2	3,28

PARALLEL GRIPPERS WITH T-GUIDE  
**SERIES CGPT - DIMENSIONAL CHARACTERISTICS**

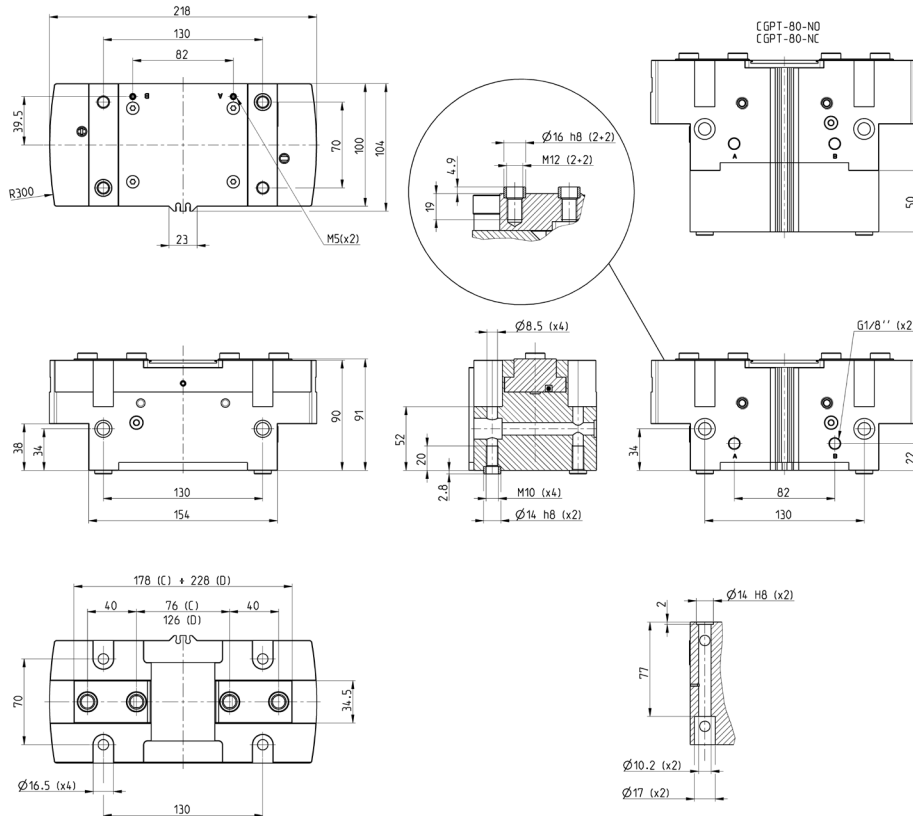
Gripper - size 80 mm



**DRAWING LEGEND:**  
**A** = Opening of air connection  
**B** = Closing of air connection  
**C** = Closed gripper  
**D** = Open gripper

Mod.	Total closing gripping force at 6 bar (N)	Closing gripping force each jaw at 6 bar (N)	Total opening gripping force at 6 bar (N)	Opening gripping force each jaw at 6 bar (N)	Stroke per jaw (mm)	Working pressure (bar)	Working temperature (°C)	Repeatability (mm)	Max use frequency (Hz)	Weight (kg)
CGPT-80	2818	1409	3168	1584	25	2 ÷ 8	5 ÷ 60	0,02	1	5,16
CGPT-80-NC	3698	1849	2052	1026	25	4 ÷ 8	5 ÷ 60	0,02	1	6,89
CGPT-80-NO	1756	878	4006	2003	25	4 ÷ 8	5 ÷ 60	0,02	1	6,66

Gripping force (F) per single jaw

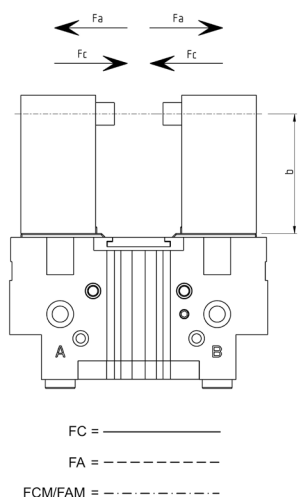

**b** = distance from gripping point  
**F<sub>a</sub>** = opening force  
**F<sub>c</sub>** = closing force  
**F<sub>AM</sub>** = opening spring force  
**F<sub>CM</sub>** = closing spring force

The total gripping force has to be calculated as follows:  
 Total  $F = F \times 2$

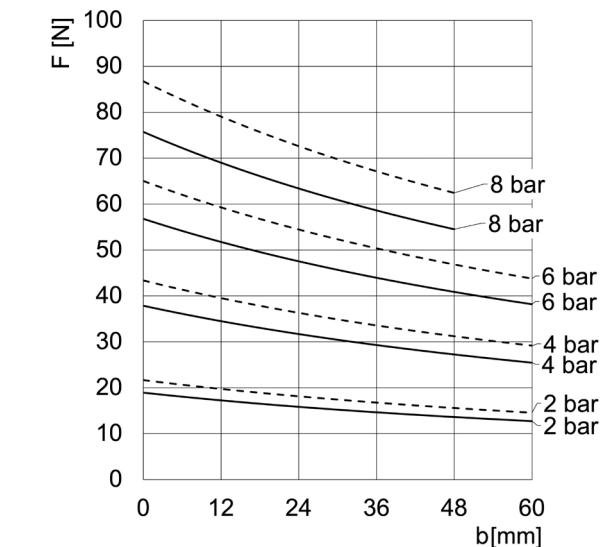

CGPT-16

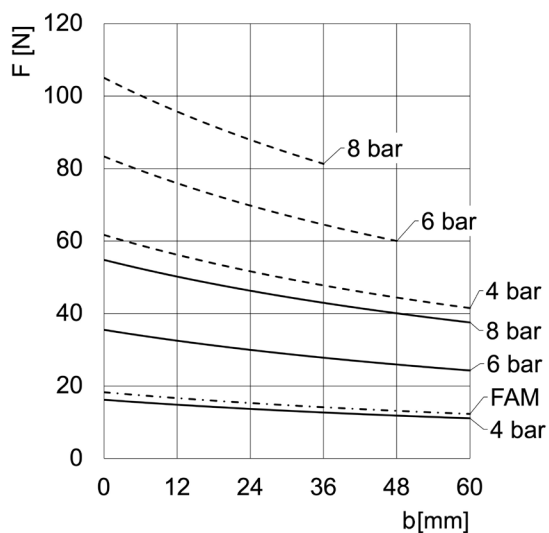

CGPT-16-NO

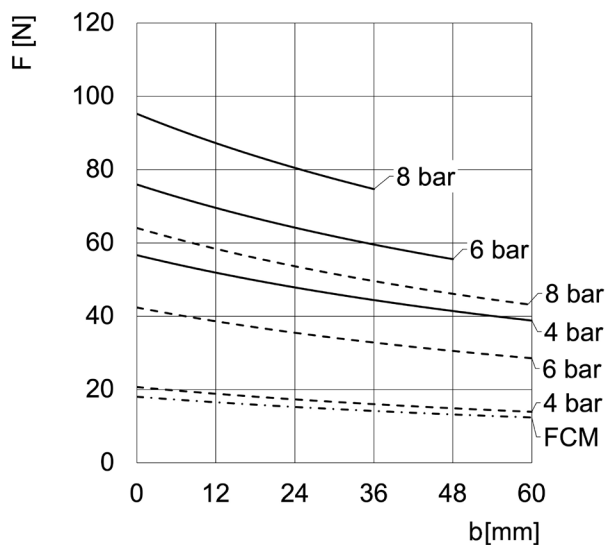

CGPT-16-NC

### Gripping force (F) per single jaw

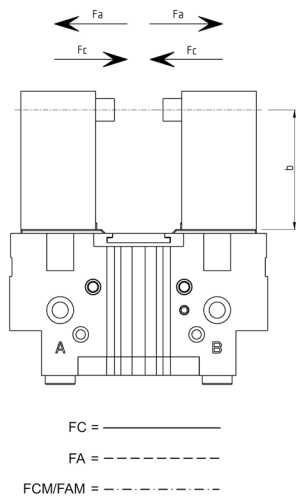

**b** = distance from gripping point  
**F<sub>A</sub>** = opening force  
**F<sub>C</sub>** = closing force  
**F<sub>AM</sub>** = opening spring force  
**F<sub>CM</sub>** = closing spring force

The total gripping force has to be calculated as follows:  
 Total F = F x 2

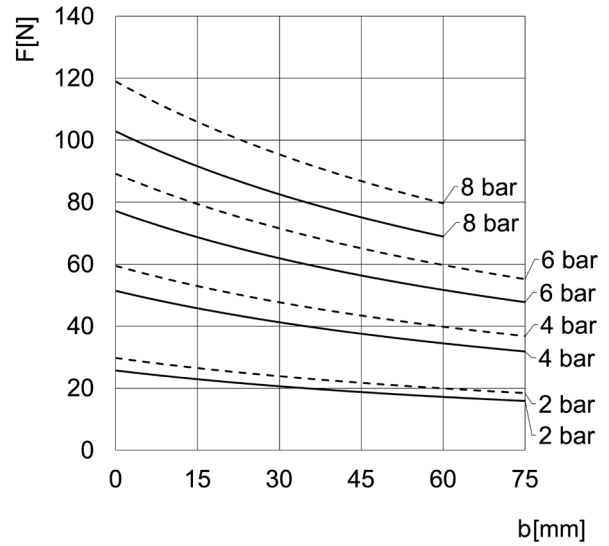

CGPT-20

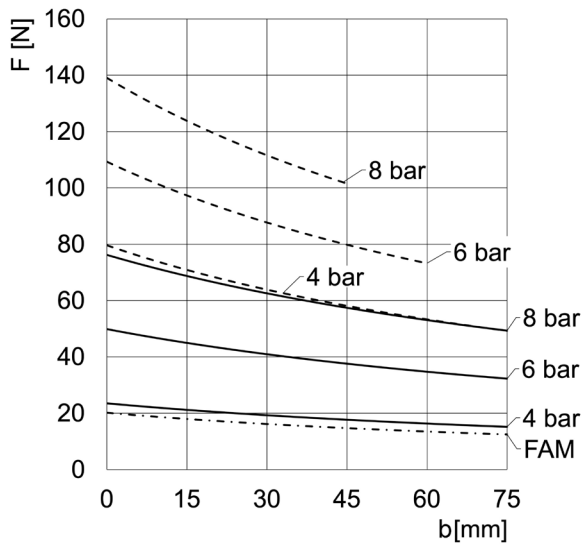

CGPT-20-NO

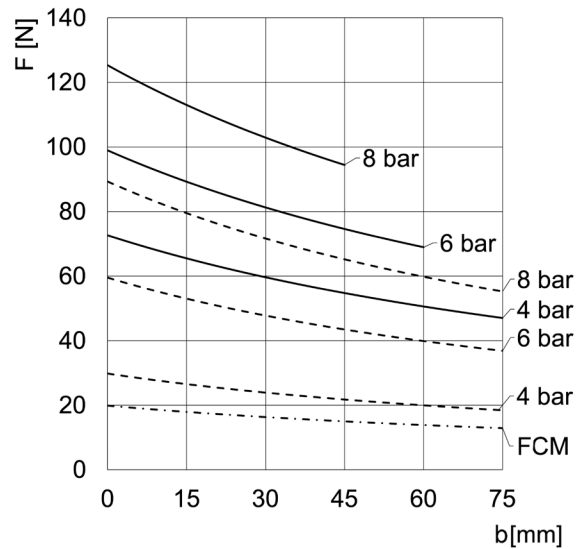

CGPT-20-NC

Gripping force (F) per single jaw

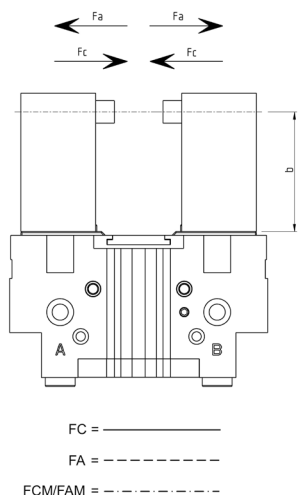

**b** = distance from gripping point  
**F<sub>a</sub>** = opening force  
**F<sub>c</sub>** = closing force  
**F<sub>AM</sub>** = opening spring force  
**F<sub>CM</sub>** = closing spring force

The total gripping force has to be calculated as follows:  
 Total F = F x 2

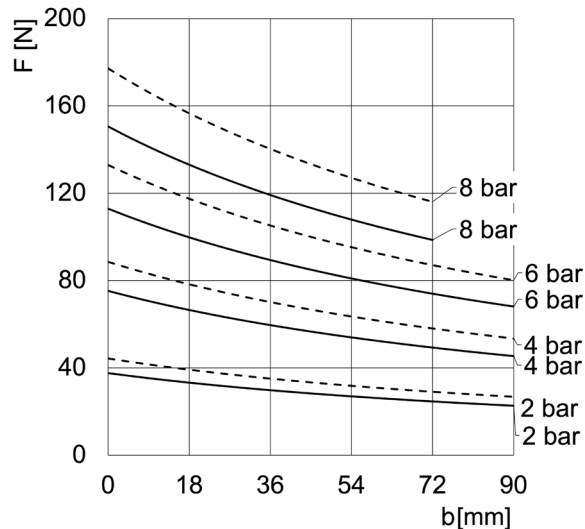

CGPT-25

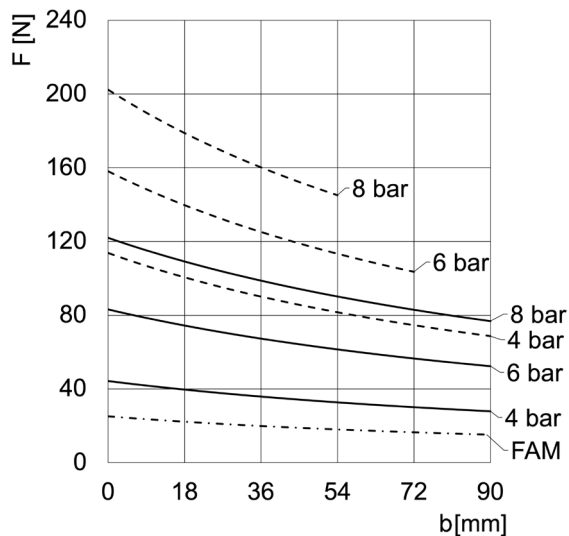

CGPT-25-NO

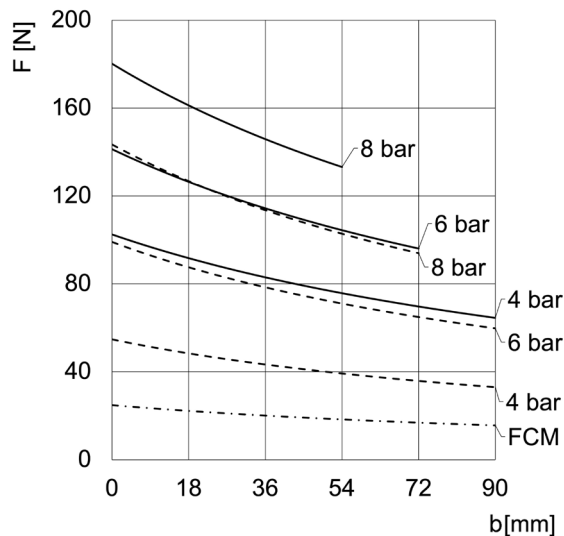

CGPT-25-NC

### Gripping force (F) per single jaw

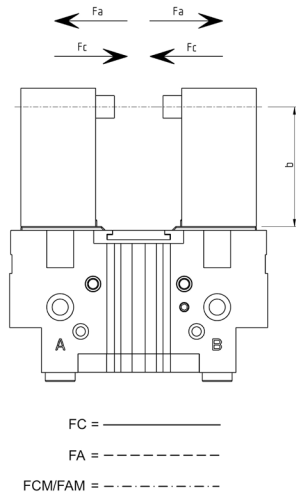

**b** = distance from gripping point  
**F<sub>a</sub>** = opening force  
**F<sub>c</sub>** = closing force  
**F<sub>AM</sub>** = opening spring force  
**F<sub>CM</sub>** = closing spring force

The total gripping force has to be calculated as follows:  
 Total  $F = F \times 2$

CGPT-32

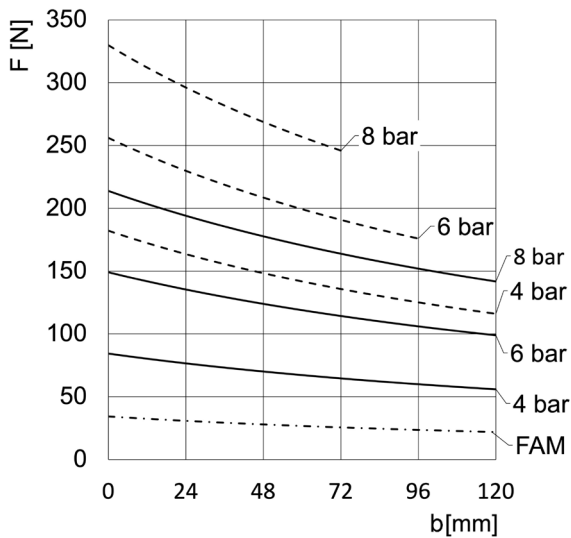
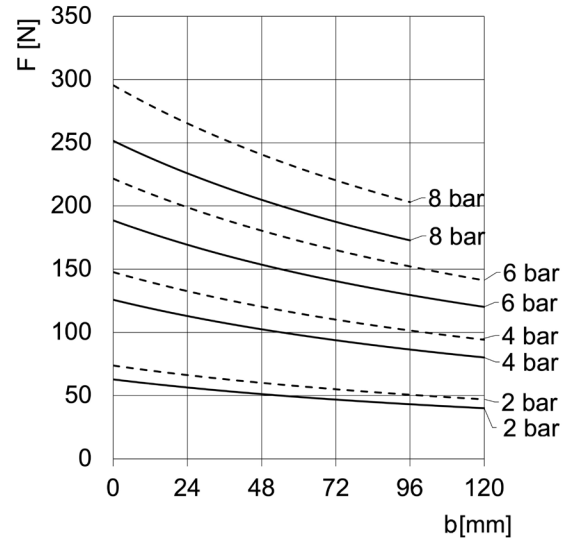

CGPT-32-NO

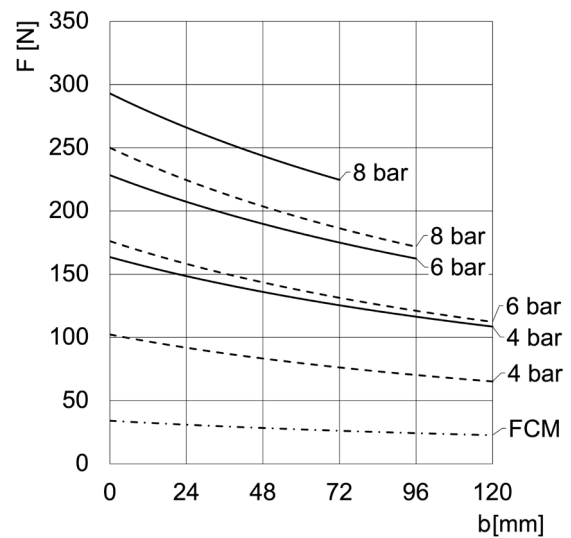

CGPT-32-NC

Gripping force (F) per single jaw

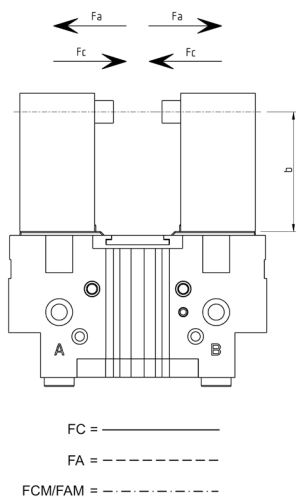

b = distance from gripping point  
FA = opening force  
FC = closing force  
FAM = opening spring force  
FCM = closing spring force

The total gripping force has to be calculated as follows:  
Total F = F x 2

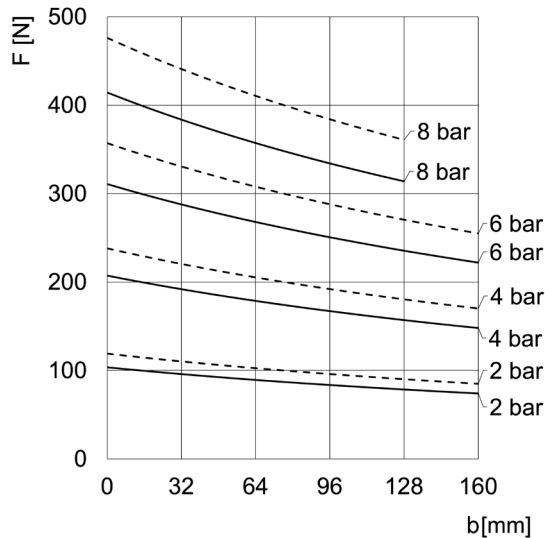

CGPT-40

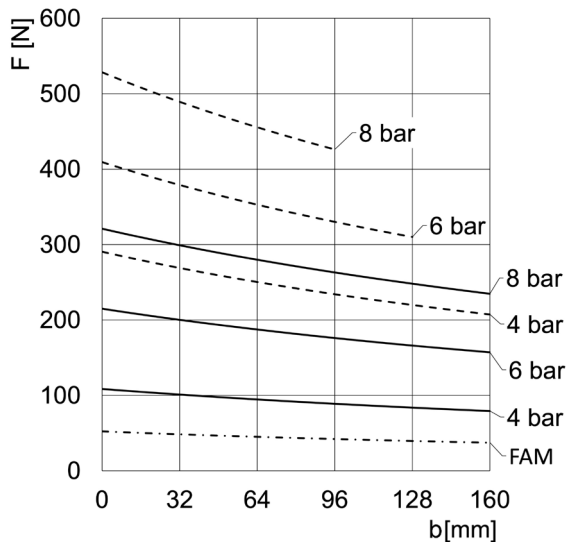

CGPT-40-NO

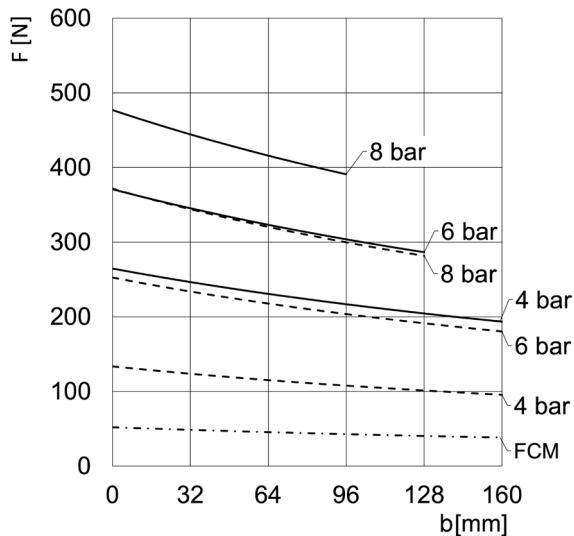

CGPT-40-NC



### Gripping force (F) per single jaw

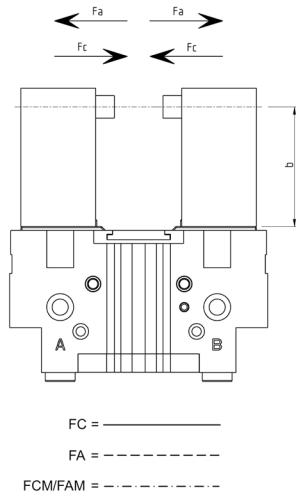

**b** = distance from gripping point  
**F<sub>a</sub>** = opening force  
**F<sub>c</sub>** = closing force  
**F<sub>AM</sub>** = opening spring force  
**F<sub>CM</sub>** = closing spring force

The total gripping force has to be calculated as follows:  
 Total F = F x 2

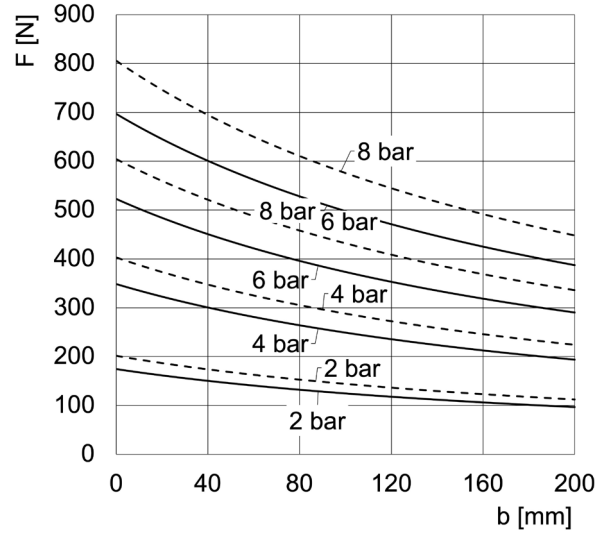

CGPT-50

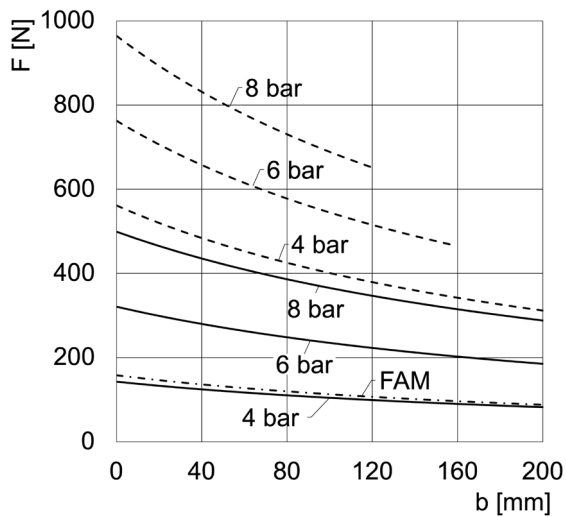

CGPT-50-NO

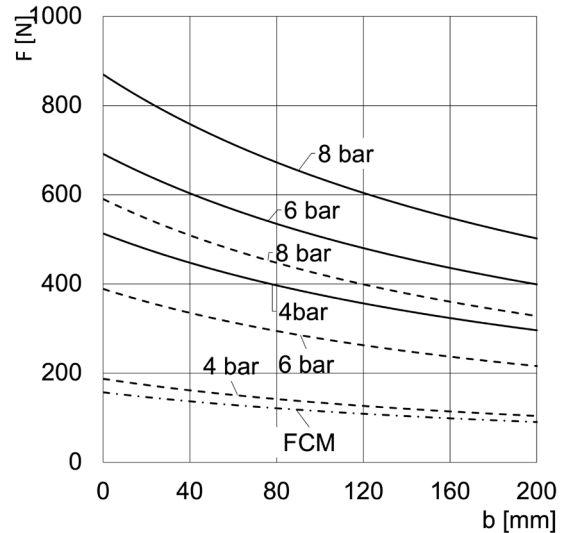

CGPT-50-NC

Gripping force (F) per single jaw

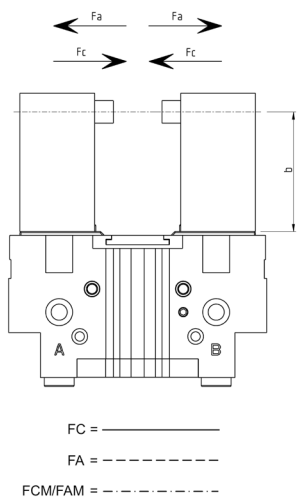

**b** = distance from gripping point  
**FA** = opening force  
**FC** = closing force  
**FAM** = opening spring force  
**FCM** = closing spring force

The total gripping force has to be calculated as follows:  
 Total  $F = F \times 2$

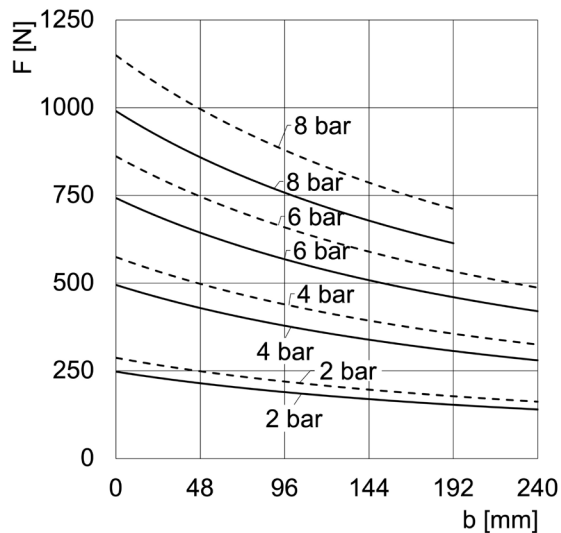

CGPT-63

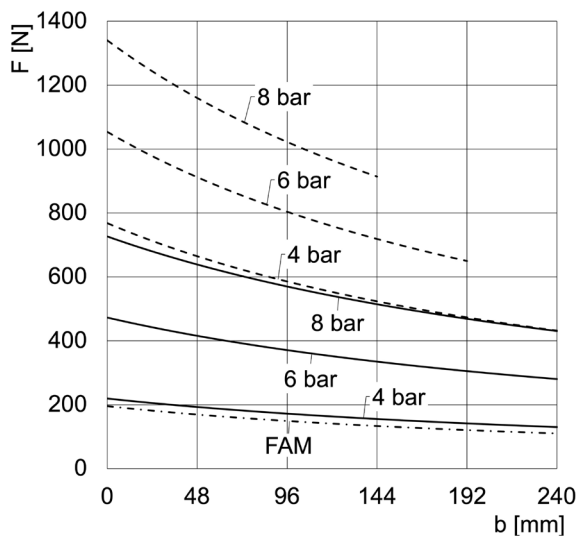

CGPT-63-NO

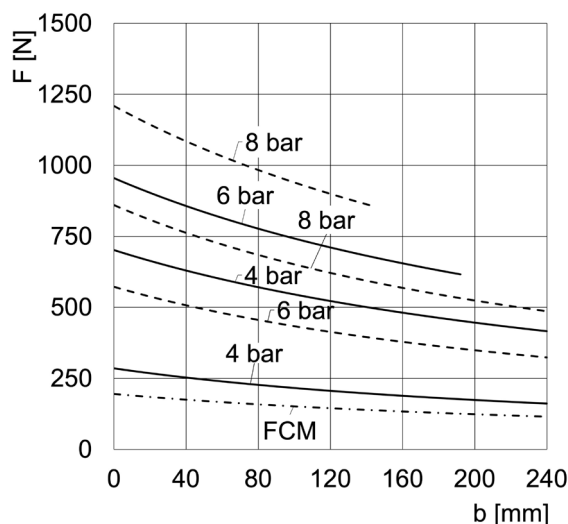

CGPT-63-NC

### Gripping force (F) per single jaw

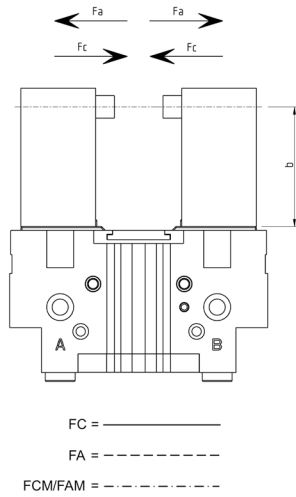

**b** = distance from gripping point  
**FA** = opening force  
**FC** = closing force  
**FAM** = opening spring force  
**FCM** = closing spring force

The total gripping force has to be calculated as follows:

Total  $F = F \times 2$

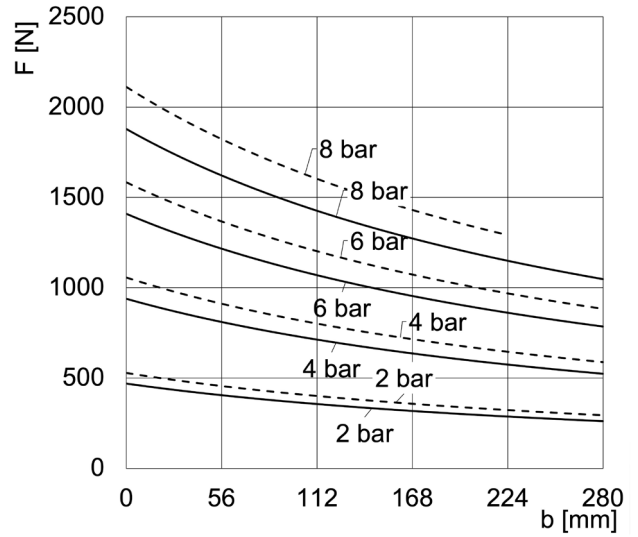

CGPT-80

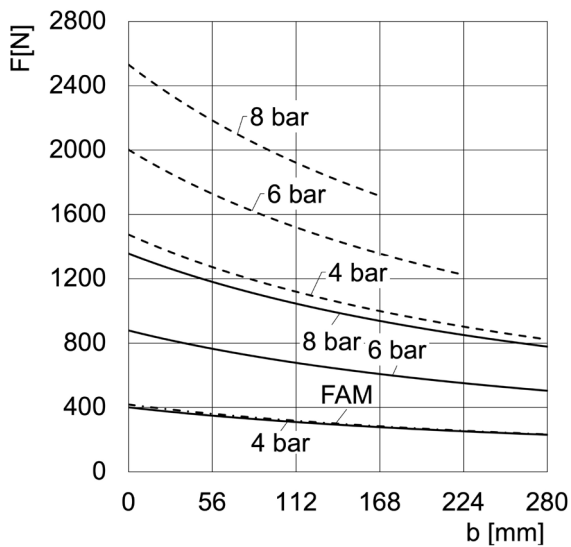

CGPT-80-NO

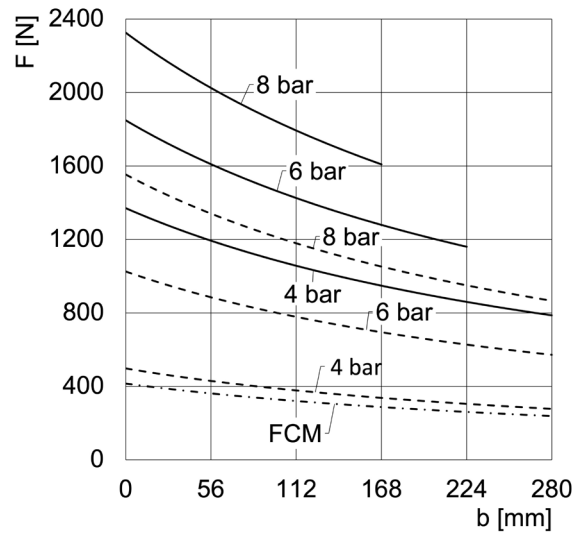

CGPT-80-NC

### Length vs eccentricity CGPT-16

The total gripping force has to be calculated as follows: Total F = F x 2.  
 Range of use of the gripper according to gripping point (b) and the arm (e).

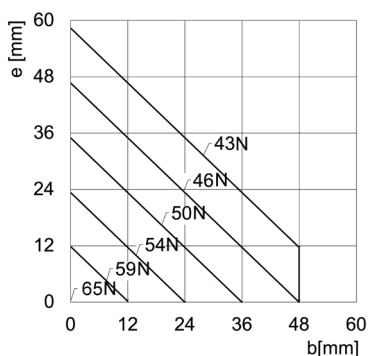
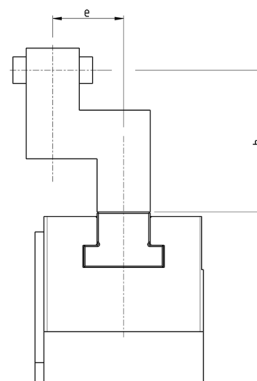

CGPT-16 opening

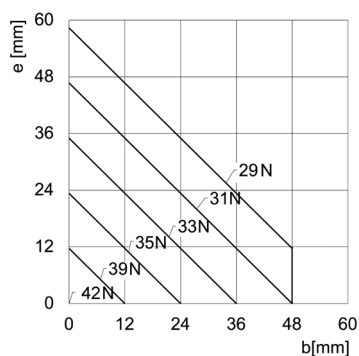

CGPT-16-NC opening

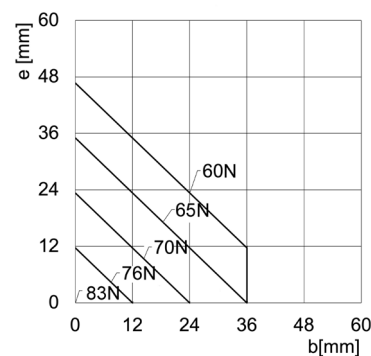

CGPT-16-NO opening

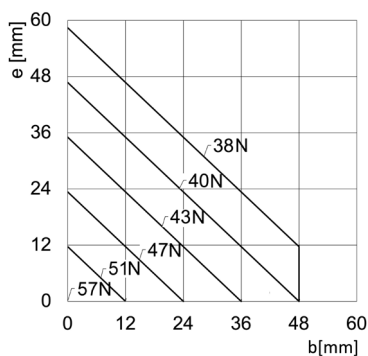

CGPT-16 closing

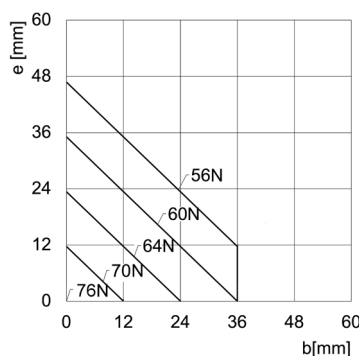

CGPT-16-NC closing

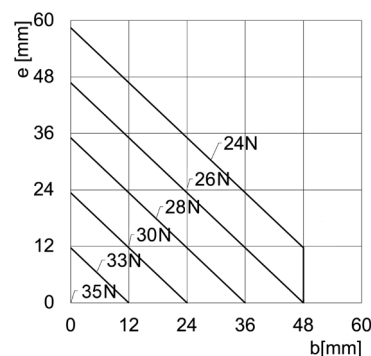

CGPT-16-NO closing

### Length vs eccentricity CGPT-20

The total gripping force has to be calculated as follows: Total F = F x 2.  
 Range of use of the gripper according to gripping point (b) and the arm (e).

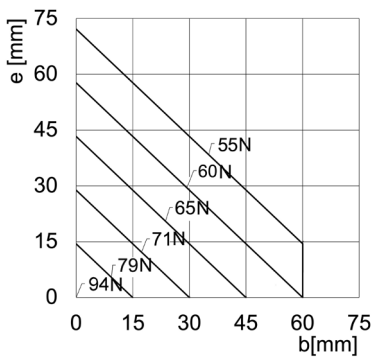
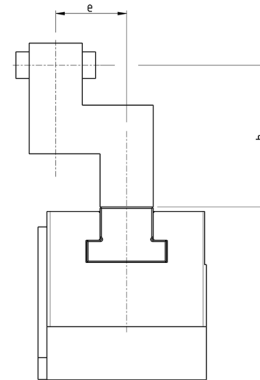

CGPT-20 opening

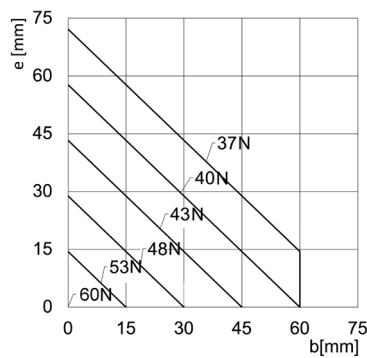

CGPT-20-NC opening

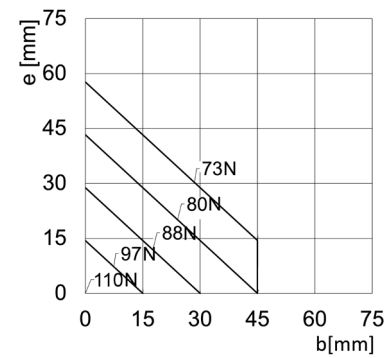

CGPT-20-NO opening

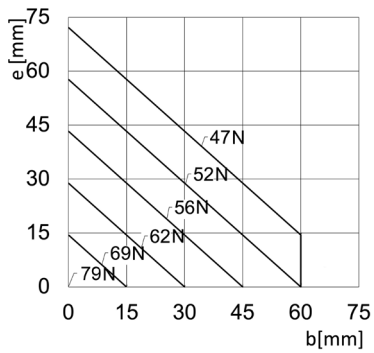

CGPT-20 closing

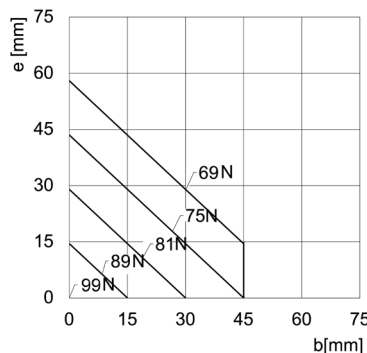

CGPT-20-NC closing

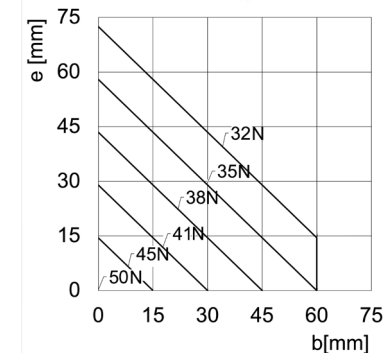

CGPT-20-NO closing

### Length vs eccentricity CGPT-25

The total gripping force has to be calculated as follows: Total F = F x 2.  
 Range of use of the gripper according to gripping point (b) and the arm (e).

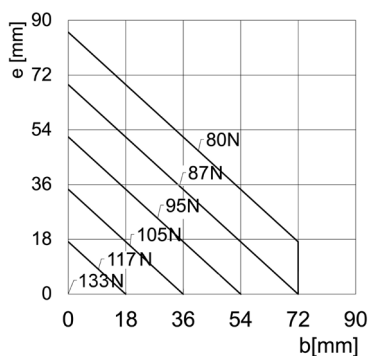
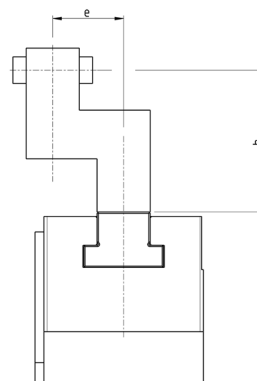

CGPT-25 opening

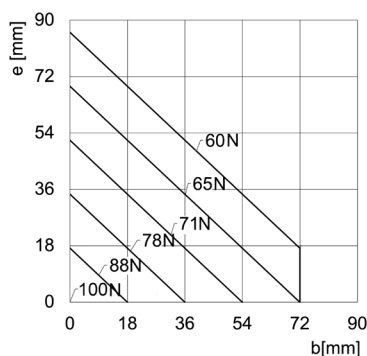

CGPT-25-NC opening

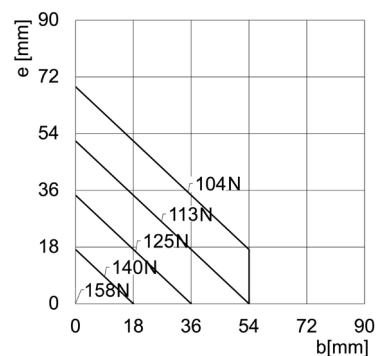

CGPT-25-NO opening

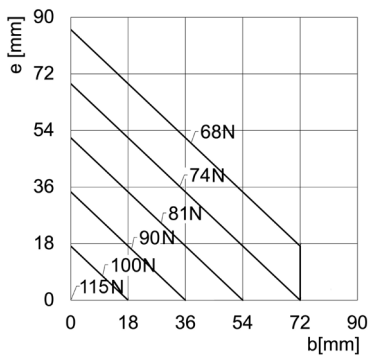

CGPT-25 closing

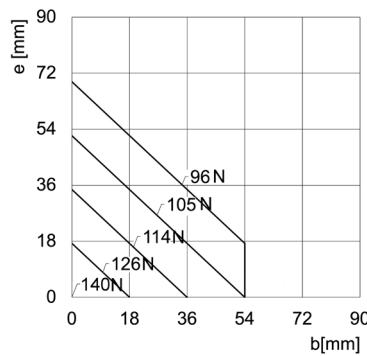

CGPT-25-NC closing

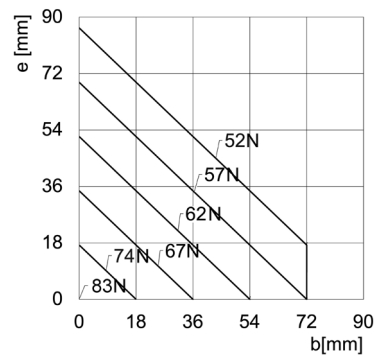

CGPT-25-NO closing

### Length vs eccentricity CGPT-32

The total gripping force has to be calculated as follows: Total F = F x 2.  
 Range of use of the gripper according to gripping point (b) and the arm (e).

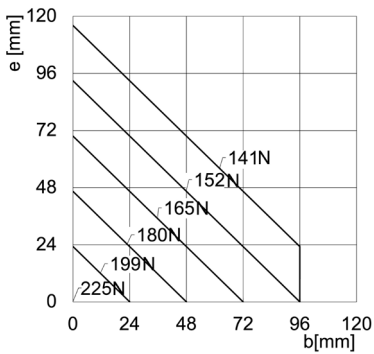
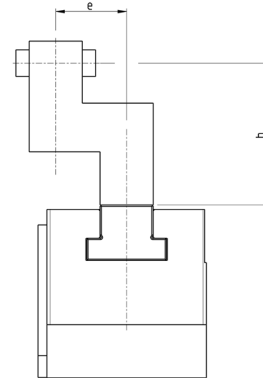

CGPT-32 opening

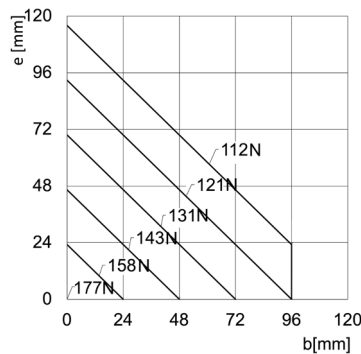

CGPT-32-NC opening

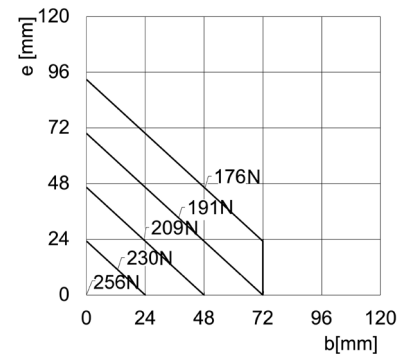

CGPT-32-NO opening

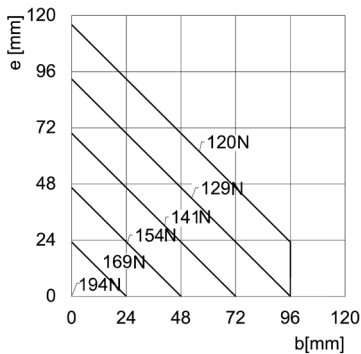

CGPT-32 closing

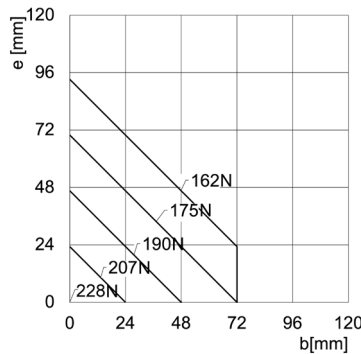

CGPT-32-NC closing

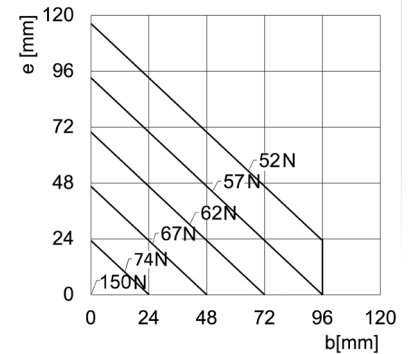

CGPT-32-NO closing

### Length vs eccentricity CGPT-40

The total gripping force has to be calculated as follows: Total F = F x 2.  
 Range of use of the gripper according to gripping point (b) and the arm (e).

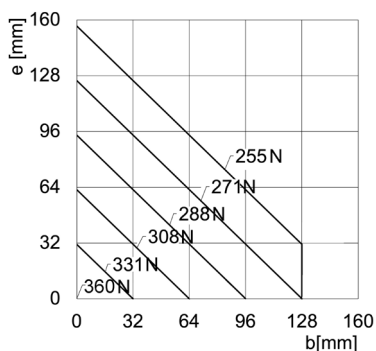
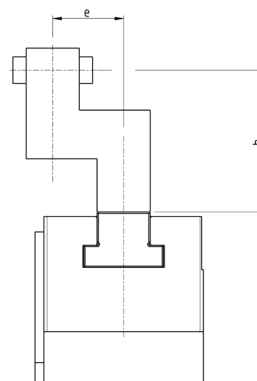

CGPT-40 opening

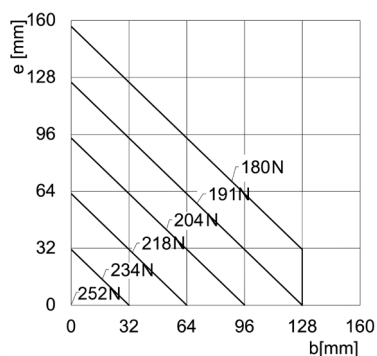

CGPT-40-NC opening

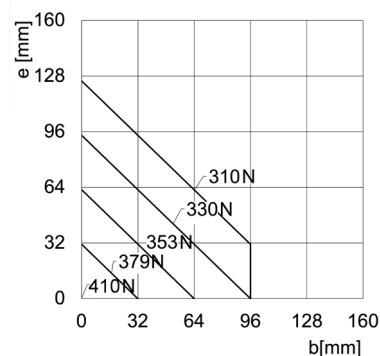

CGPT-40-NO opening

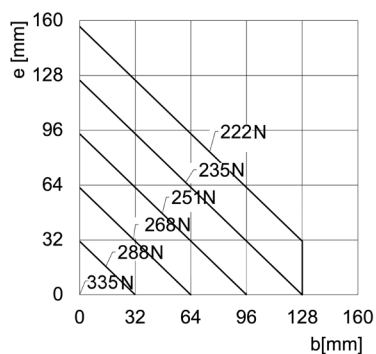

CGPT-40 closing

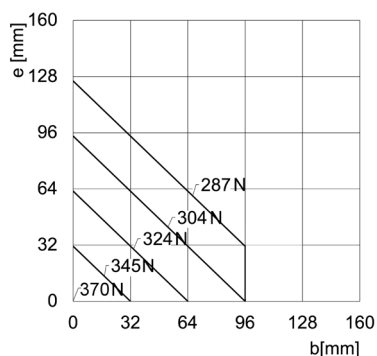

CGPT-40-NC closing

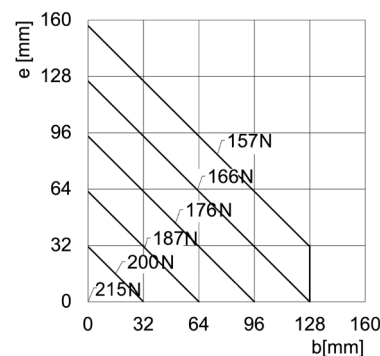

CGPT-40-NO closing



### Length vs eccentricity CGPT-50

The total gripping force has to be calculated as follows: Total F = F x 2.  
 Range of use of the gripper according to gripping point (b) and the arm (e).

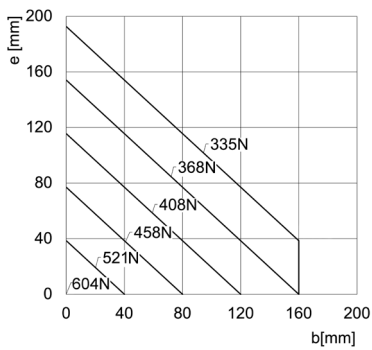
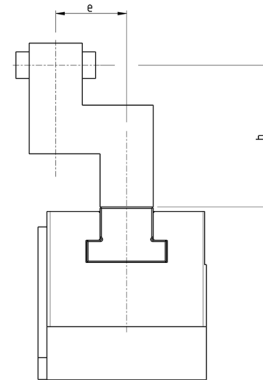

CGPT-50 opening

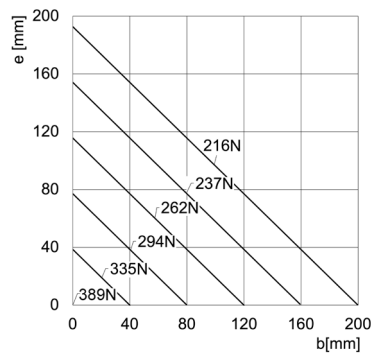

CGPT-50-NC opening

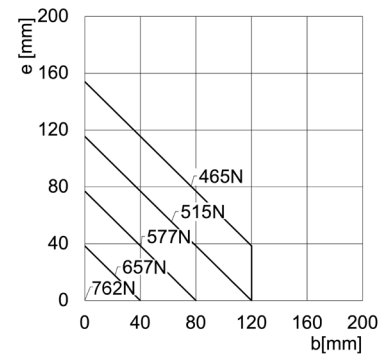

CGPT-50-NO opening

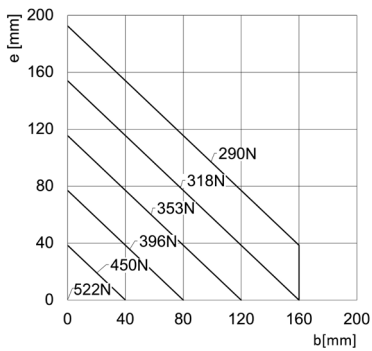

CGPT-50 closing

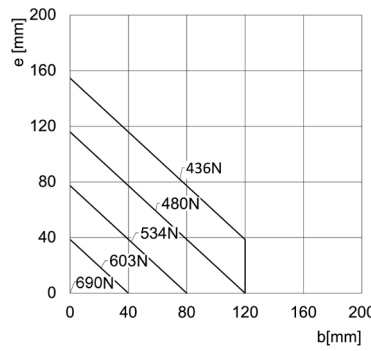

CGPT-50-NC closing

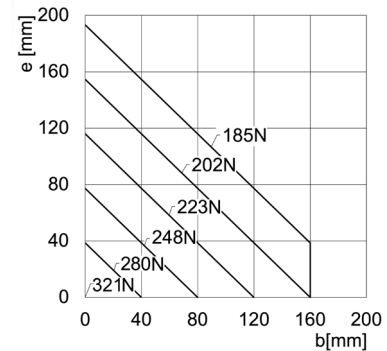

CGPT-50-NO closing

### Length vs eccentricity CGPT-63

The total gripping force has to be calculated as follows: Total F = F x 2.  
Range of use of the gripper according to gripping point (b) and the arm (e).

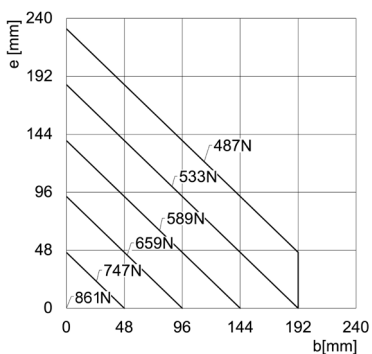
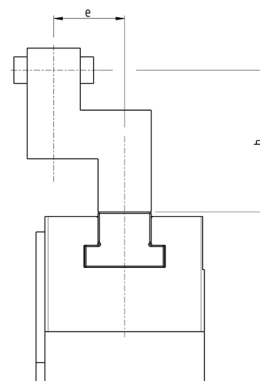

CGPT-63 opening

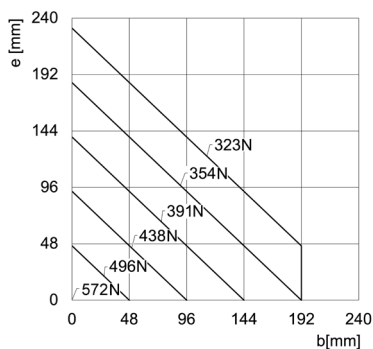

CGPT-63-NC opening

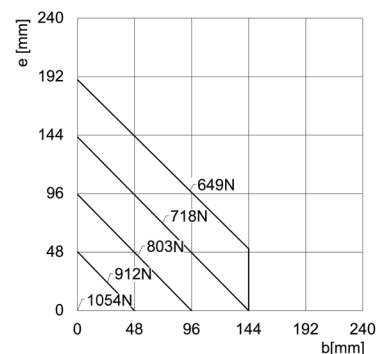

CGPT-63-NO opening

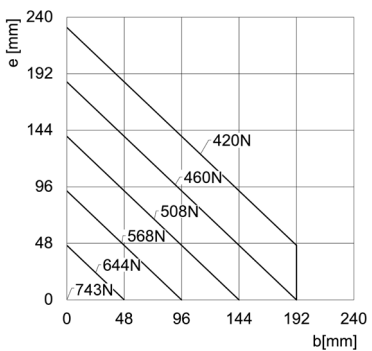

CGPT-63 closing

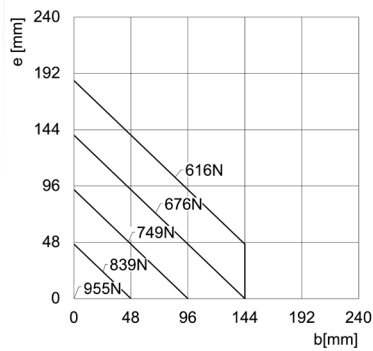

CGPT-63-NC closing

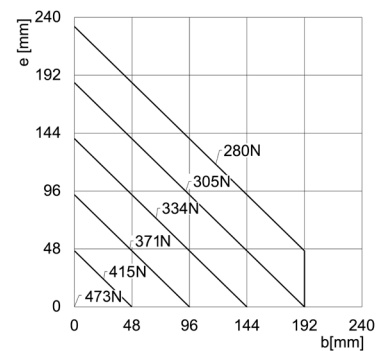

CGPT-63-NO closing

### Length vs eccentricity CGPT-80

The total gripping force has to be calculated as follows: Total F = F x 2.  
 Range of use of the gripper according to gripping point (b) and the arm (e).

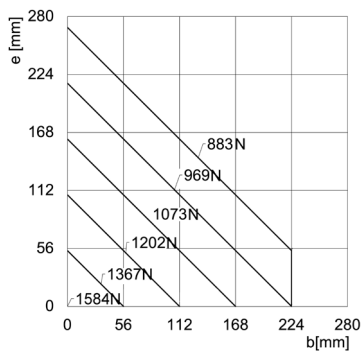
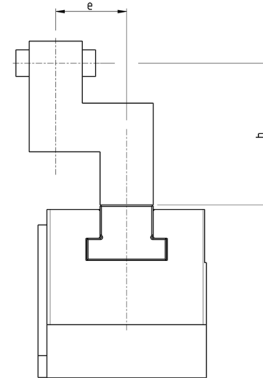

CGPT-80 opening

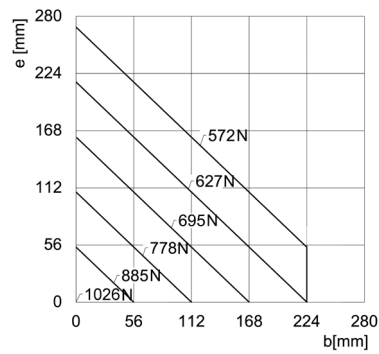

CGPT-80-NC opening

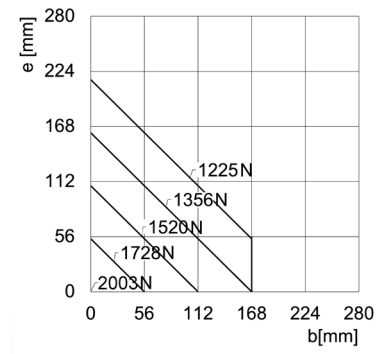

CGPT-80-NO opening

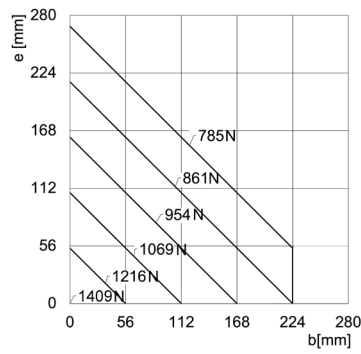

CGPT-80 closing

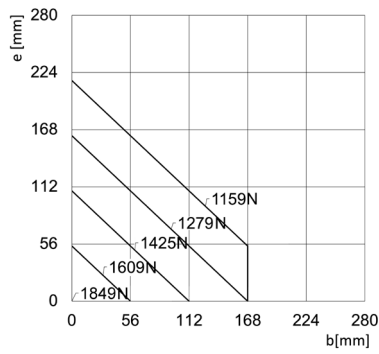

CGPT-80-NC closing

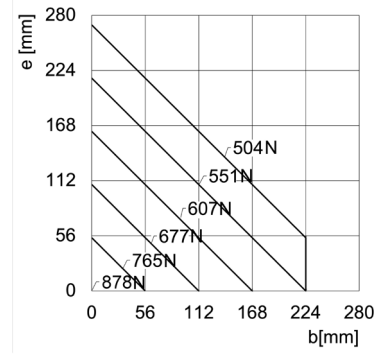

CGPT-80-NO closing

## Examples of mounting

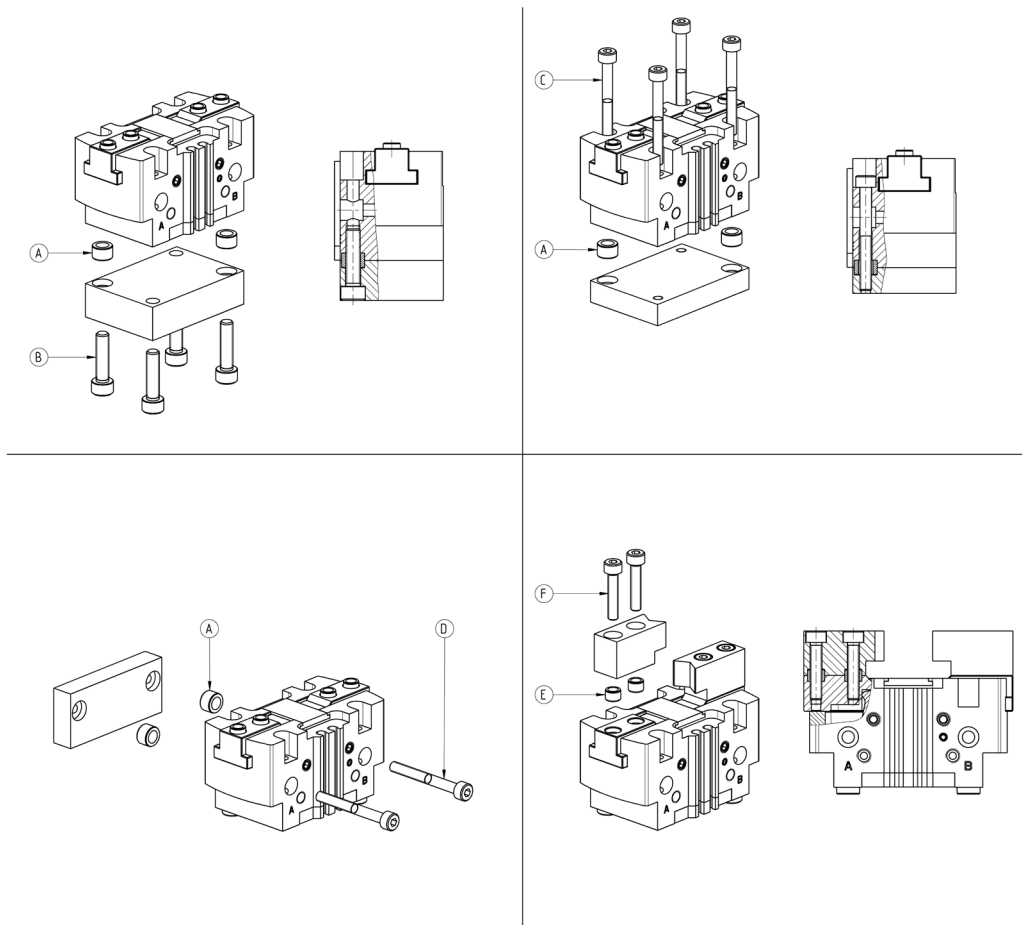

Mod.	A	B	C	D	E	F
CGPT-16	Ø5	M3	M2,5	M2,5	Ø4	M2,5
CGPT-20	Ø6	M4	M3	M3	Ø5	M3
CGPT-25	Ø8	M5	M4	M4	Ø6	M4
CGPT-32	Ø8	M5	M4	M5	Ø8	M5
CGPT-40	Ø10	M6	M5	M6	Ø10	M6
CGPT-50	Ø12	M8	M6	M8	Ø10	M6
CGPT-63	Ø12	M8	M6	M8	Ø14	M10
CGPT-80	Ø14	M10	M8	M10	Ø16	M12

## Air supply ports

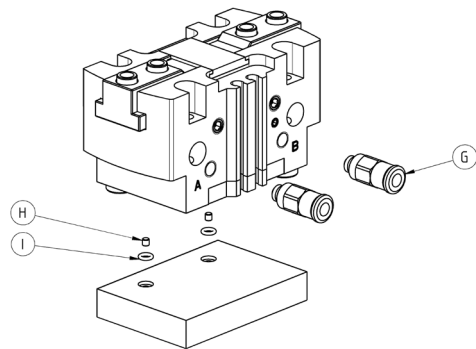

Mod.	G	H	I
CGPT-16	M3	M2	OR 2,5x1
CGPT-20	M5	M2	OR 2,5x1
CGPT-25	M5	M2	OR 2,5x1
CGPT-32	M5	M3	OR 3,5x1
CGPT-40	G1/8	M3	OR 3,5x1
CGPT-50	G1/8	M3	OR 3,5x1
CGPT-63	G1/8	M5	OR 5,28x1,78
CGPT-80	G1/8	M5	OR 5,28x1,78

## Example of use of the pressurization/lubrication hole

Example of use of the lubrication (greasing) or pressurization hole of the zone with moving items.

- 1: grease the sliding zones using Molykote DX grease.
- 2: supply a pressure of max. 3 bar in order to avoid the sudden ejection of grease.

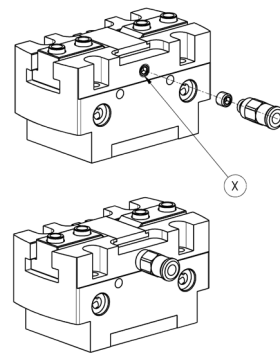

Mod.	X
CGPT-16	M3
CGPT-20	M5
CGPT-25	M5
CGPT-32	M5
CGPT-40	M5
CGPT-50	M5
CGPT-63	M5
CGPT-80	M5

**PARALLEL GRIPPERS WITH T-GUIDE**  
**SERIES CGPT - CATEGORIA DA INSERIRE**
**Example of mounting: sensors**

L = sensor mod. CSD-D-334 or mod. CSD-D-364

In order to position the sensor correctly, a channel must be created in the base.

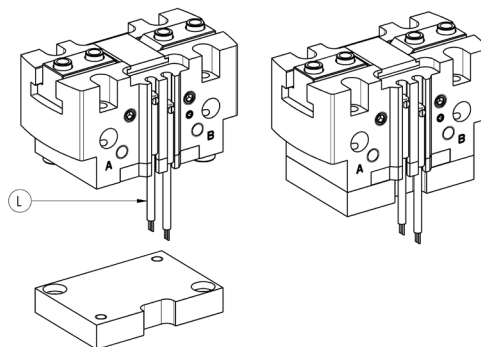

GRIPPERS

**3**

Mod.	L
CGPT-16	CSD...
CGPT-20	CSD...
CGPT-25	CSD...
CGPT-32	CSD...
CGPT-40	CSD...
CGPT-50	CSD...
CGPT-63	CSD...
CGPT-80	CSD...

**Inductive sensor kit**

**Supplied with:**  
 2x fixing screws  
 1x blocking screw  
 1x plate

\* use 1,5 mm Allen key to adjust the reading position of the inductive sensor.

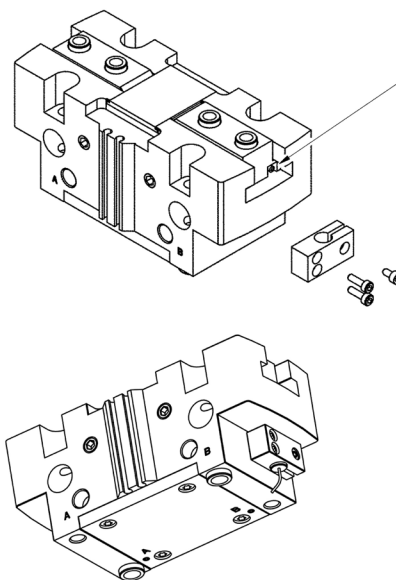

Mod.	
CGPT-50	P-CGPT
CGPT-63	P-CGPT
CGPT-80	P-CGPT

**Series CSD magnetic proximity switches, 3-wire cable, D-slot**

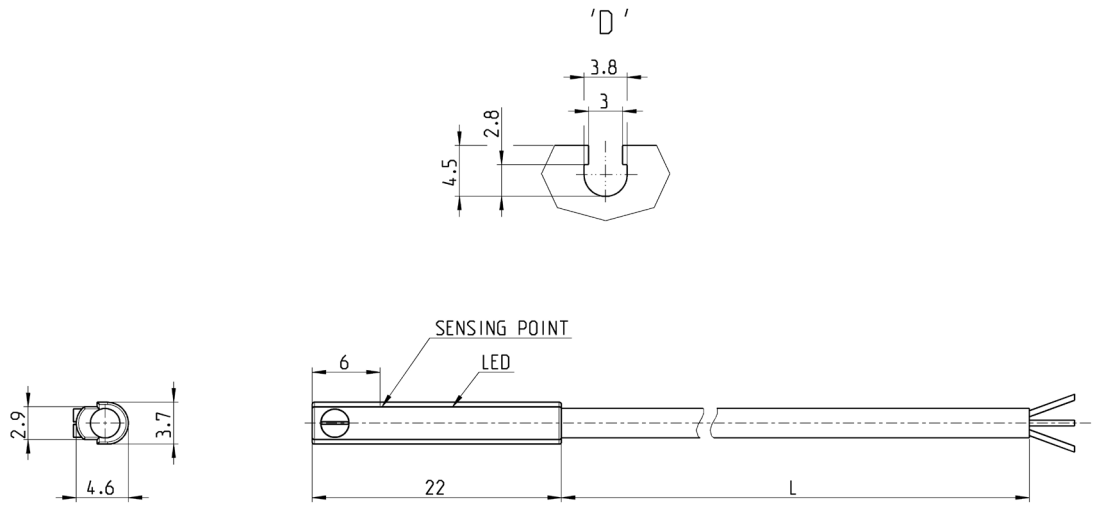

Mod.	Operation	Connections	Voltage	Output	Max. current	Max Load	Protection	L = length cable
CSD-D-334	Magneto-resistive	3 wires	10 ÷ 27 V DC	PNP	200 mA	6W	Against polarity reversing and overvoltage	2 m

**Magnetic sensors Series CSD, conn. male M8 3 pin, hollow D, straight**

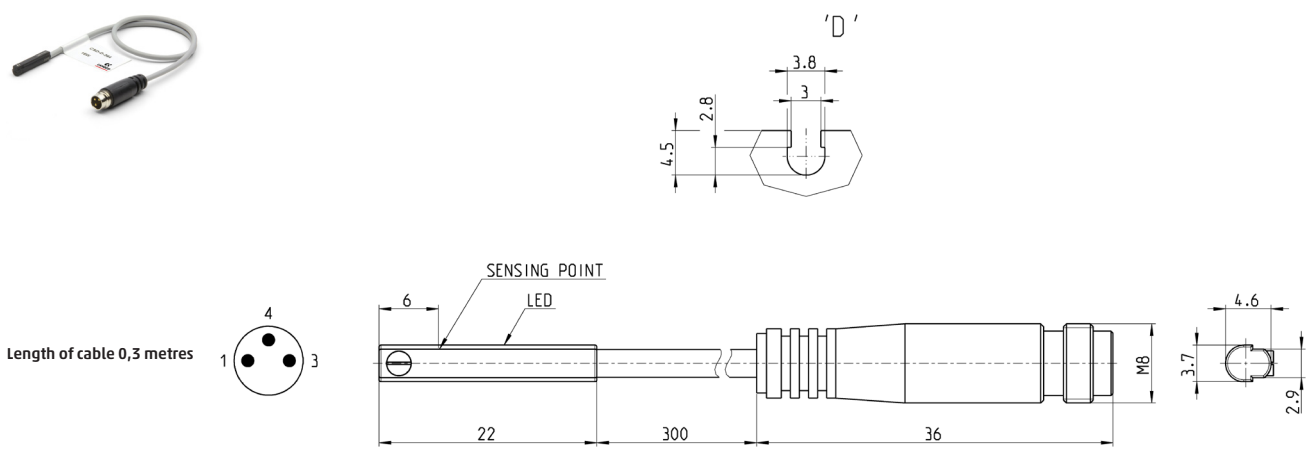

Mod.	Operation	Connection	Voltage	Output	Max. current	Max Load	Protection
CSD-D-364	Magneto-resistive	3 wires with M8 connector	10 ÷ 27 V DC	PNP	200 mA	6W	Against polarity reversing and overvoltage