

Electromagnetic brakes

Construction and mode of operation

The stator body must be installed concentrically with the output side. For further installation advises and technical details, please refer to page 28.

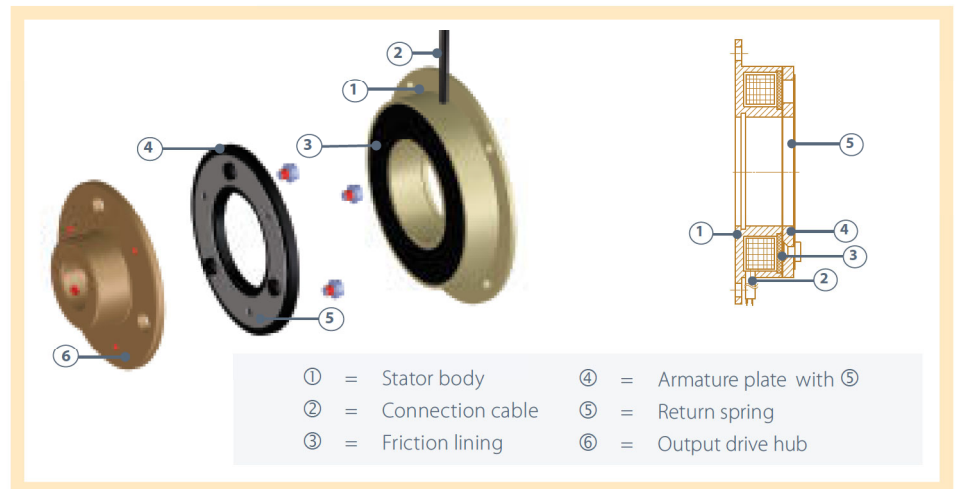

Model A

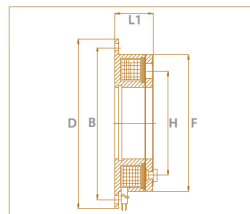

Brake without hub
Basic version without drive hub.
Connection to output side by screws.

Model B

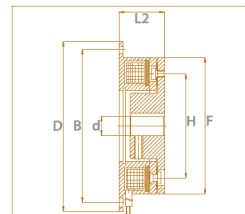

Brake with internal hub
Basic version with axial output drive. Internal hub.

Model C

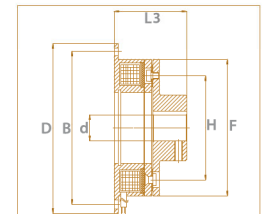

Brake with external hub
Basic version with axial output drive. External hub.

Performance data and dimensions

Size	B02	B03	B04	B05	B06	B07	B08	B09
Torque [Nm] For reference purposes ¹⁾	1.0	4.5	8.0	20.0	38.0	80.0	150.0	280.0
Speed of rotation max. [rpm]	10.000	8.000	6.000	5.000	4.000	3.000	3.000	2.000
Power [W] T = 20° C	9	12	20	23	32	40	55	72
d max. [mm] ²⁾	8	17	20	30	35	42	50	75
D [mm]	60	80	100	125	150	190	230	290
L1 [mm]	21.0	22.0	24.5	28.0	31.0	35.0	41.5	48.0
L2 [mm]	24.0	25.5	28.5	33.0	37.5	42.0	50.4	59.0
L3 [mm]	33.0	37.0	44.5	53.0	61.0	73.0	89.5	103.0
B [mm]	52	72	90	112	137	175	215	270
F [mm]	42	63	80	100	125	160	200	250
H [mm]	29	46	60	76	95	120	158	210

¹⁾ Depending on design of installation, operating and ambient conditions

²⁾ Keyway to DIN 6885/1

Key to model codes

