



MINIMESS®

Trendsetting details and innovations

Expertise in everything having to do with hydraulic measuring technology is one of the main constants behind the history of Hydrotechnik. In fact, the **MINIMESS®** plug-in coupling featuring a ball check was first launched on the market in 1964, immediately redefining what was possible in the field of pressure measuring technology for hydraulic systems. And it was no surprise, as the advantages behind the novel development were immediately compelling: Instead of having to open the hydraulic circuit and install a pressure gauge for diagnostic or maintenance activities, the innovation had suddenly made it possible to quickly and safely connect pressure sensors and gauges without any downtime.

The name Hydrotechnik has long been considered a standard-bearer in the area of hydraulic measuring equipment, and that is even before the introduction of its new leak-proof test point with a soft seal in 1982.

Previous developments such as the **MINIMESS®** p/T test point, which can be used to measure pressure and temperature at a single measuring point directly in a fluid, and the **MINIMESS®** gas charging valve, with its excellent gas tightness, had already made it clear that Hydrotechnik GmbH was a force of innovation to be reckoned with.

From small-scale handmade batches to series production

From the very moment Hydrotechnik GmbH was

founded, every single product has been made at the company's headquarters in Limburg an der Lahn. A high level of vertical integration and lean processes enable us to quickly respond to our customers' needs – from handmade small-scale production for the most demanding measuring tasks to mass production. Hydrotechnik GmbH always uses the best approach to provide users with safe, high-quality products that are specifically fine-tuned to match their requirements.

The future looks bright

By continuously enhancing and developing its products for applications in an extremely wide variety of industries and combining that with decades of experience, Hydrotechnik GmbH has remained an unrivaled partner for products and services that go far beyond the classic test point.

From the project phase, through prototypes, to the finished product, we actively support our customers worldwide with the implementation of their projects. In fact, we are known for implementing the most extraordinary applications without ever losing focus on the big picture or on detail and utmost meticulousness. An international presence and unrivalled experience with the **MINIMESS®** make us the ideal partner for your needs – today and well into the future.

MINIMESS®

ORIGINAL MINIMESS® TEST POINTS

The go-to system access solution for fluid circuit analyses, sampling, charging, and venting.

The p/T version can be used to measure pressures and temperatures at a single measuring point at the same time.

1620 series – Page 12 - 13



1620 p/T s



ORIGINAL MINIMESS^{XTREME}® TEST POINTS

Pressures of up to 1,000 bar, immersion depths of up to 5,000 m, and temperatures as low as -60 °C are simply a matter of course for these high-performance products. In other words, they are the product of choice for the most demanding measuring tasks out there.

Offshore – Page 20



Deep Sea –



ORIGINAL MINIMESS® GAS CHARGING VALVES AND ACCESSORIES

Designed to make it easy, fast, and safe to fill, monitor, and empty gas accumulators and gas-conveying lines.

Gas charging valves – Page 23



DVGW test



ADAPTERS WITH ORIGINAL MINIMESS® TEST POINTS

Used to retrofit test points on existing systems. New installations? Combining measuring points? Not a problem.

DKO fittings – Pages 28 – 33



DKO combi
Page 34 - 37



MINIMESS® GAUGE AND SENSOR ADAPTERS, HOSE LINES, AND ACCESSORIES

Connect your pressure gauges and sensors directly to your test point or use one of our MINIMESS® hose lines. In addition, this group includes hose materials parts designed for the MINIMESS® Xtreme.

Gauge and sensor adapters – Page 43 - 45



Hose lines –



EXPANDED MINIMESS® PORTFOLIO

Special solutions for your technical fluid applications that are designed to complement our range of traditional MINIMESS® products.

Minivalv throttle check valve
Page 58



FlatFaced
Page 59



Series – Page 14



1615 series – Page 15



1215 series – Page 16 - 17



1604 series – Page 19



Page 20



Special Fluids – Page 20



Low Temperatures – Page 21



Pressure – Page 21



Point – Page 24



Gas charging valve with accumulator adapter
Page 25



Accumulator charging and testing device
Page 26



Gas charging and testing device with pressure regulator
Page 26



Swivel fittings / tee adapters



90° swivel fittings – Page 38



Bulkhead versions – Page 39 - 40



Sleeves for ORFS and 37° flared fitting
Page 41 - 42



Page 47 - 56



Gauge and sensor adapters for bulkheads – Page 57



Diagnostic couplings



Test couplings for air brake systems – Page 59



Original MINIMESS® test points

The benchmark for test couplings

MINIMESS® test points serve as system access points for analyses and tests in fluid circuits, and can be used to make a leak-tight connection under pressure. This makes it possible to connect sensors or pressure gauges or draw samples as necessary without any downtimes. Moreover, the test points can be used to fill, vent, and empty systems.

Original MINIMESS® test points

- | Are an integral part of measuring and testing equipment
- | Can be used to make leak-tight connections under pressure
- | Open and close automatically when a hose or sensor is connected / disconnected
- | Save time and money by making diagnostics and maintenance faster, improving machine availability as a result
- | Save money by ensuring that expensive sensors do not have to be permanently installed for servicing purposes
- | Conform to ISO 15171-2 (MINIMESS® 1620)
- | Have a four-fold safety factor in regard to bursting
- | Are certified with 1,000,000 pressure pulses at 1.3 times the operating pressure
- | Can also be used at low temperatures
- | Are highly resistant to corrosion (salt spray test longer than 1,000 hours)
- | Are suitable, without restrictions, for HL, HLP, HVLP hydraulic fluids in conformity with DIN 51524

The **original MINIMESS® 1620 p/T test point** is a multipurpose test point that can be used to simultaneously measure pressure and temperature at a single measuring point. As a result, the number of required measuring points can be reduced by up to 50%.

The temperature is measured directly in the flowing fluid, resulting in extremely short response times.

For information on compatible HySense® p/T combo sensors, please refer to page 144.

Test point	Screw cap thread	Nominal diameter	Max. operating pressure ¹	Material selection	Seal materials
MINIMESS® 1620	M16x2	DN2	630 bar	1.0718 free cutting steel 1.4571 stainless steel	NBR (Perbunan) FKM (Viton)
MINIMESS® 1620 p/T	M16x2	DN2	630 bar		
MINIMESS® 1615	M16x1,5	DN2	630 bar		
MINIMESS® 1215	Buttress thread 12	DN2	630 bar		
MINIMESS® 1604	Buttress thread 16	DN4	400 bar		

Additional materials and seal materials available upon request.

¹ Depends on the size of the stud end.



Original MINIMESS® 1620 test point

The MINIMESS® 1620 test point with an M16 x 2 thread is the top seller among test couplings and is used for most standard applications. It can be used with operating pressures of up to 630 bar and is available in a wide variety of versions with various international threads and seal types.

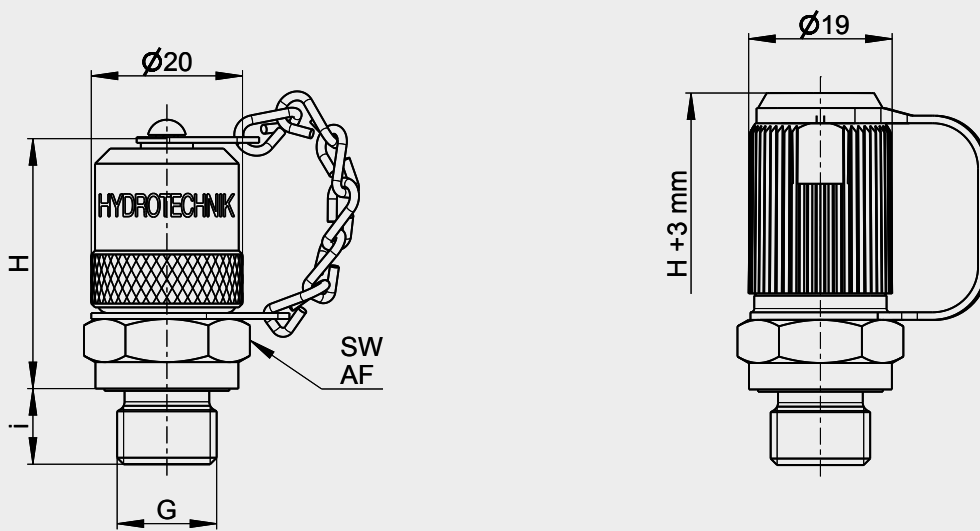

Version with metal cap

Version with plastic cap

Seal types

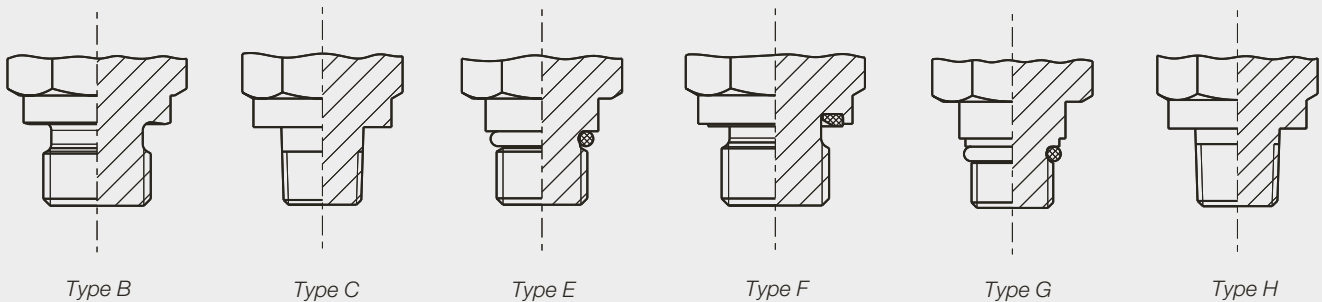

Type B

Type C

Type E

Type F

Type G

Type H

Thread	Seal type ¹	Technical specifications					Material: 1.0718 free cutting steel	Material: 1.4571 Stainless steel
		M ² Nm	p _n ³ bar	H mm	i mm	AF mm	Part No. with metal cap & NBR seals	Part No. with metal cap & FKM seals
Metric ISO thread								
M10 x 1	E	20	630	37.5	9.5	17	2103-01-94.00N	–
M10 x 1	F	20	400	37.6	8	17	2103-01-12.00N	2703-01-12.10
M10 x 1	G	15	630	37.5	8.5	17	2103-01-33.00N	2703-01-33.10
M12 x 1.5	B	45	630	36	10	17	2103-01-48.00N	–
M12 x 1.5	E	35	630	35.1	11	17	2103-01-95.00N	–
M12 x 1.5	F	45	630	36	10	17	2103-01-13.00N	2703-01-13.10
M14 x 1.5	B	60	630	36	10	19	2103-01-49.00N	–
M14 x 1.5	E	45	630	35.5	11	19	2103-01-96.00N	–
M14 x 1.5	F	60	630	36	10	19	2103-01-14.00N	2703-01-14.10
M16 x 1.5	F	80	630	36	10	22	2103-01-15.00N	–
Whitworth thread								
ISO 228-G 1/8	F	20	400	38	8	17	2103-01-17.00N	2703-01-17.10
ISO 228-G 1/4	B	60	630	36	10	19	2103-01-51.00N	2703-01-51.10
ISO 228-G 1/4	F	60	630	36	10	19	2103-01-18.00N	2703-01-18.10
ISO 228-G 3/8	F	90	630	36	10	22	2103-01-16.00N	2703-01-16.10
UNF thread								
7/16-20 UNF	E	20	630	37	11	17	2103-01-B5.00N	2703-01-B5.10
9/16-18 UNF	E	35	630	36	12	17	2103-01-B6.00N	2703-01-B6.10
Tapered thread								
ISO 7/I-R 1/8	C	–	400	33	13	17	2103-01-40.00N	–
ISO 7/I-R 1/4	C	–	630	33	13	17	2103-01-41.00N	2703-01-41.10
NPTF thread								
1/8 NPTF	H	–	400	33	9.5	17	2103-01-46.00N	–
1/4 NPTF	H	–	630	33	16.5	17	2103-01-47.00N	2703-01-47.10
Options								
Part No. with FKM seals							XXXX-XX-XX.10N	–
Part No. with plastic cap							XXXX-30-XX.XXN	XXXX-30-XX.XX
Operating temperature ranges: With NBR seals: -25 °C ... 100 °C / With FKM seals: -20 °C ... 200 °C / With plastic cap: Max. 100 °C								
Additional versions, materials, and seal materials available upon request.								

¹ For detailed specifications regarding the seal types, please refer to pages 62 – 64

² M = Tightening torque for stud end in conformity with the applicable standards. It is the user's own responsibility to determine the appropriate installation torque for their specific installation situation.

³ p_n = Maximum operating pressure

Original MINIMESS® 1620 p/T test point

The MINIMESS® 1620 p/T test point can be used to simultaneously measure pressure and temperature with only one single test coupling by using a p/T multipurpose sensor. This results in fewer measuring points and sensors being required.

The p/T test point can be used with operating pressures of up to 630 bar.

Seal types

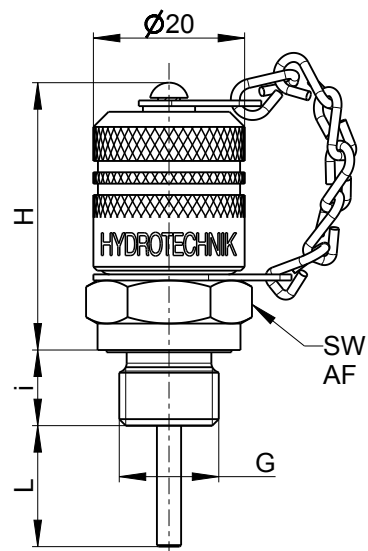
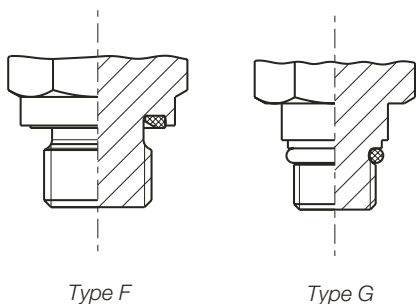

Thread	Seal type ¹	Technical specifications							Material: 1.0718 free cutting steel	Material: 1.4571 Stainless steel
		M ² Nm	p _n ³ bar	H mm	i mm	L mm	AF mm	Part No. with metal cap & NBR seals	Part No. with metal cap & FKM seals	
Metric ISO thread										
M10 x 1	G	15	630	38	8.5	16	17	2149-04-19.13N	2749-04-19.53	
Whitworth thread										
ISO 228-G 1/4	F	60	630	36.5	10	16	19	2149-04-15.13N	2749-04-15.53	
Options										
Part No. with FKM seals								XXXX-XX-XX.53N	–	
Part No. with EPDM seals								XXXX-XX-XX.43N	–	
Operating temperature ranges: With NBR seals: -25 °C ... 100 °C / With FKM seals: -20 °C ... 200 °C / With EPDM seal: -40 °C ... 125 °C										
Additional versions, materials, and seal materials available upon request.										

¹ For detailed specifications regarding the seal types, please refer to pages 62 – 64

² M = Tightening torque for stud end in conformity with the applicable standards. It is the user's own responsibility to determine the appropriate installation torque for their specific installation situation.

³ p_n = Maximum operating pressure

Original MINIMESS® 1615 test point

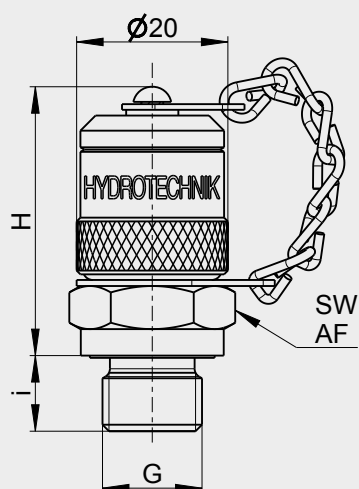

The MINIMESS® 1615 test point was developed primarily for military applications and has an alternative M16 x 1.5 coupling thread available. It can be used with operating pressures of up to 630 bar and is available with various threads.

Seal types

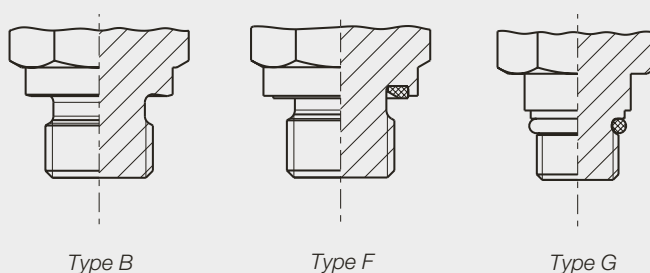

Thread	Seal type ¹	Technical specifications					Material: 1.0718 free cutting steel	Material: 1.4571 Stainless steel
		M ² Nm	p _n ³ bar	H mm	i mm	AF mm	Part No. with metal cap & NBR seals	Part No. with metal cap & FKM seals
Metric ISO thread								
M10 x 1	G	15	630	37.5	8.5	17	2102-01-33.00N	2702-01-33.10
M12 x 1.5	F	45	630	36	10	17	2102-01-13.00N	2702-01-13.10
M14 x 1.5	B	60	630	36	10	19	2102-01-49.00N	–
M14 x 1.5	F	60	630	36	10	19	2102-01-14.00N	2702-01-14.10
Whitworth thread								
ISO 228-G 1/8	F	20	400	38	8	17	2102-01-17.00N	–
ISO 228-G 1/4	B	60	630	36	10	19	2102-01-51.00N	–
ISO 228-G 1/4	F	60	630	36	10	19	2102-01-18.00N	2702-01-18.10
Options								
Part No. with FKM seals						XXXX-XX-XX.10N	–	
Operating temperature ranges: With NBR seals: -25 °C ... 100 °C / With FKM seals: -20 °C ... 200 °C								
Additional versions, materials, and seal materials available upon request.								

¹ For detailed specifications regarding the seal types, please refer to pages 62 – 64

² M = Tightening torque for stud end in conformity with the applicable standards. It is the user's own responsibility to determine the appropriate installation torque for their specific installation situation.

³ p_n = Maximum operating pressure

Original MINIMESS® 1215 test point

The MINIMESS® 1215 test point is characterized by a small coupling thread, resulting in a very compact design. It was originally developed as an alternative test point for metrological applications in places where space is tight. The test point can be used with operating pressures of up to 630 bar and is available with various international threads and seal types.

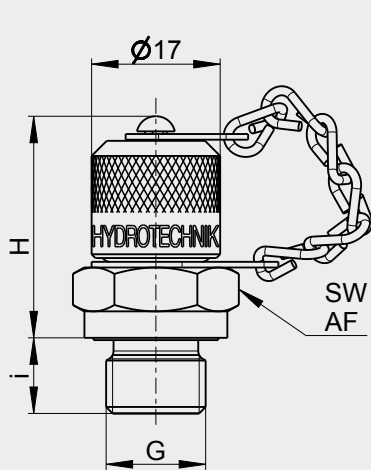

Version with metal cap

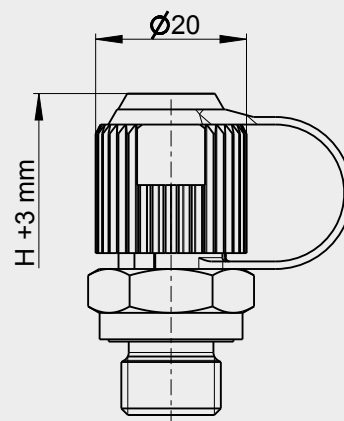

Version with plastic cap

Seal types

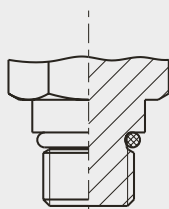

Type E

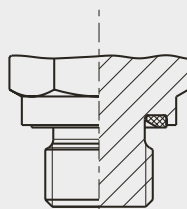

Type F

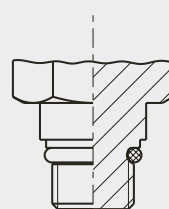

Type G

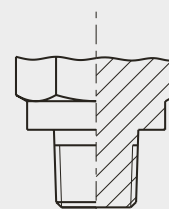

Type H

Thread	Seal type ¹	Technical specifications					Material: 1.0718 free cutting steel	Material: 1.4571 Stainless steel
		M ² Nm	p _n ³ bar	H mm	i mm	AF mm	Part No. with metal cap & NBR seals	Part No. with metal cap & FKM seals
Metric ISO thread								
M10 x 1	G	15	630	30	8.5	14	2101-06-33.00N	2701-06-33.10
M12 x 1.5	E	35	630	29	11	17	2101-06-76.00N	–
M12 x 1.5	F	45	630	29	10	17	2101-06-13.00N	–
M14 x 1.5	E	45	630	29	11	19	2101-06-96.00N	–
M14 x 1.5	F	60	630	29	10	19	2101-06-14.00N	–
Whitworth thread								
ISO 228-G 1/8	F	20	400	30	8	14	2101-06-17.00N	2701-06-17.10
ISO 228-G 1/4	F	60	630	29	10	19	2101-06-18.00N	2701-06-18.10
UNF thread								
7/16-20 UNF	E	20	630	29	11	17	2101-06-B5.00N	2701-06-B5.10
9/16-18 UNF	E	35	630	28	12	17	2101-06-B6.00N	–
Tapered thread								
1/8 NPTF	H	–	400	26	12	14	2101-06-46.00N	2701-06-46.10
1/4 NPTF	H	–	630	26	15	14	2101-06-47.00N	2701-06-47.10
Options								
Part No. with FKM seals						XXXX-XX-XX.10N		–
Part No. with plastic cap						XXXX-01-XX.XXN		XXXX-01-XX.XX
Operating temperature ranges: With NBR seals: -25 °C ... 100 °C / With FKM seals: -20 °C ... 200 °C / With plastic cap: Max. 100 °C								
Additional versions, materials, and seal materials available upon request.								

¹ For detailed specifications regarding the seal types, please refer to pages 62 – 64

² M = Tightening torque for stud end in conformity with the applicable standards. It is the user's own responsibility to determine the appropriate installation torque for their specific installation situation.

³ p_n = Maximum operating pressure

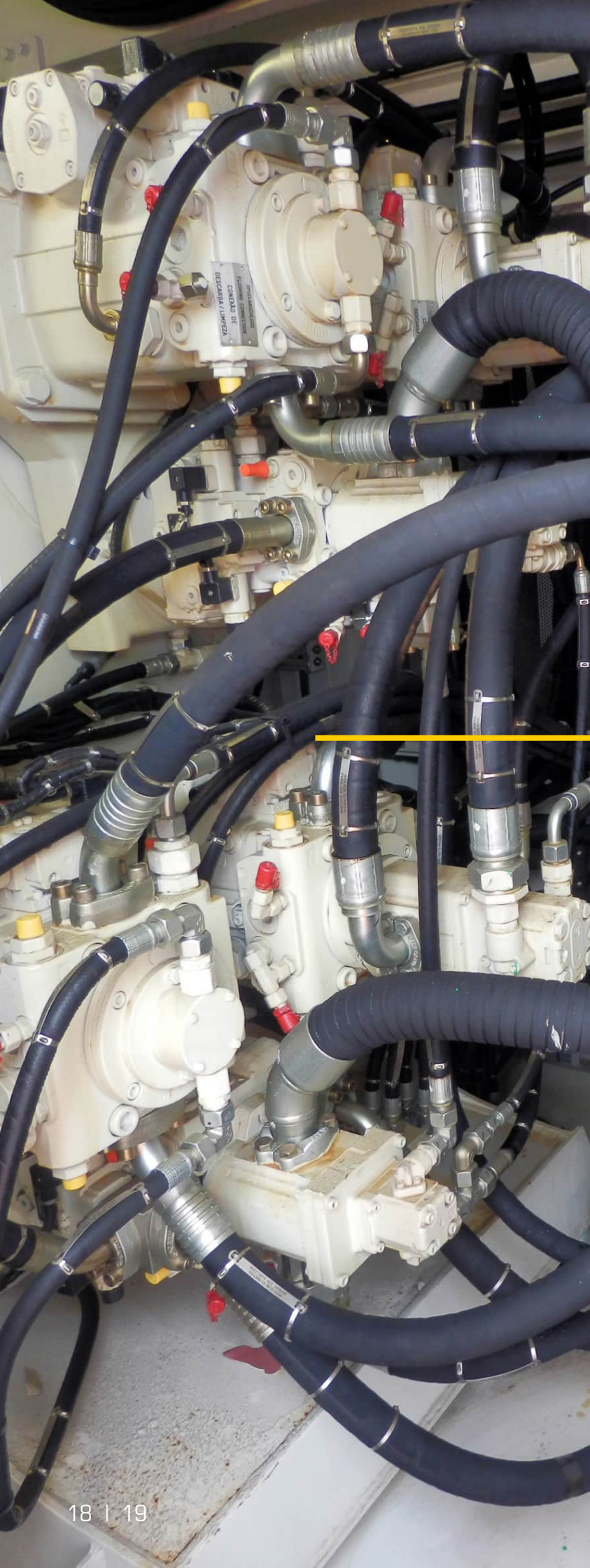

Original MINIMESS® 1604 test point

The MINIMESS® 1604 test point is particularly suitable for quickly filling or emptying systems as a result of its nominal diameter of DN4.

The test point can be used with operating pressures of up to 400 bar and is available with various threads.

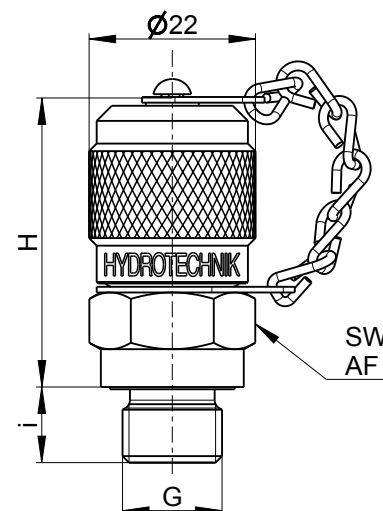

Seal types

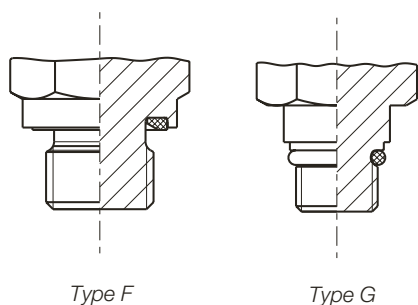

Thread	Seal type ¹	Technical specifications					Material: 1.0718 free cutting steel	Material: 1.4571 Stainless steel
		M ² Nm	p _n ³ bar	H mm	i mm	AF mm	Part No. with metal cap & NBR seals	Part No. with metal cap & FKM seals
Metric ISO thread								
M10 x 1	G	15	400	43	8.5	17	2106-01-33.00N	—
M12 x 1.5	F	45	400	40	10	17	2106-01-13.00N	—
M14 x 1.5	F	60	400	40	10	19	2106-01-14.00N	—
Whitworth thread								
ISO 228-G 1/4	F	60	400	40	10	19	2106-01-18.00N	2706-01-18.10
Options								
Part No. with FKM seals							XXXX-XX-XX.10N	—
Operating temperature ranges: With NBR seals: -25 °C ... 100 °C / With FKM seals: -20 °C ... 200 °C								
Additional versions, materials, and seal materials available upon request.								

¹ For detailed specifications regarding the seal types, please refer to pages 62 – 64

² M = Tightening torque for stud end in conformity with the applicable standards. It is the user's own responsibility to determine the appropriate installation torque for their specific installation situation.

³ p_n = Maximum operating pressure

Original MINIMESS[®]Xtreme[®] test points for liquids and gases

Offshore

MINIMESS[®] Offshore series test points and gas charging valves were developed for direct contact with salt water, and their premium stainless steel construction enables them to withstand the extreme environmental conditions present at sea.

- | Body, internal parts, and cap made of corrosion-resistant 1.4571 stainless steel
- | Can be used with temperatures as low as -40 °C
- | Splash-proof



Deep Sea

MINIMESS[®] Deep Sea series test points and gas charging valves are designed for high ambient pressures of up to 500 bar.

Moreover, their special construction makes it possible to use them safely at deep depths by reliably preventing the ingress of salt water.

- | Designed to withstand ambient pressures of up to 500 bar and depths of up to 5,000 meters
- | Body, internal parts, and cap made of corrosion-resistant 1.4571 stainless steel
- | Absolutely no leaks when subjected to internal and ambient pressure



Fluids

MINIMESS[®] test points for special fluids are characterized by high chemical and thermal resistance. This is particularly important for the chemical, aviation, and vehicle manufacture industries, which use fluids that entail special requirements for seal materials. It also means that MINIMESS[®] test points for special media can be used for an extremely wide variety of applications.

- | High chemical resistance against aviation hydraulic fluid (Skydrol[®]), brake fluid (DOT3 to DOT5), etc.
- | High resistance to temperatures of up to more than 300 °C when using special FFKM seals
- | Available with a free cutting steel or stainless steel body



Low Temperature

MINIMESS® low-temperature test points, which are made of stainless steel, can be used at extremely low temperatures. The secret consists of special seal materials that ensure safe and reliable sealing under extreme cold conditions.

- | Can be used with temperatures as low as -60 °C
- | Premium-grade elastomers
- | We also have compatible low-temperature hoses available



Pressure

The new MINIMESS® high-pressure test point combines all the characteristics of our classic MINIMESS® test points with a significantly higher pressure resistance. The test point is tested with four times its maximum operating pressure in order to guarantee the safety of its users.

- | Operating pressures of up to 1,000 bar
- | Burst pressure > 4,000 bar
- | Long service life: > 1,000,000 pressure pulses at 1,330 bar



Original MINIMESS® gas charging valves and accessories

Original MINIMESS® gas charging valves are designed to make it easy and fast to fill, empty, and test hydraulic accumulators. Moreover, they can be used as system access points for maintenance, monitoring, and analysis tasks on gas-conveying systems.

On top of this, extraordinarily low leakage flow rates make MINIMESS® gas charging valves the ideal choice for long-term use in systems with extremely demanding safety requirements as well.

Original MINIMESS® gas charging valves

- | Feature extraordinary gas tightness with a leakage flow rate $< 2 \cdot 10^{-5}$ mbar·l/s (He) within a permissible temperature range of -20 °C to 135 °C
- | Can be used to make connections under pressure
- | Open and close automatically when a charging device or sensor is connected / disconnected
- | Save time and money by making diagnostics and maintenance faster, improving machine availability as a result
- | Save money by ensuring that expensive sensors do not have to be permanently installed for servicing purposes
- | Have a four-fold safety factor in regard to bursting
- | Can also be used at low temperatures
- | Are made of corrosion-resistant stainless steel
- | Are suitable for all inert gases



Original MINIMESS® 1615 gas charging valve

The original MINIMESS® 1615 gas charging valve is designed specifically for use with inert gases and features an extraordinary low gas leakage flow rate of less than $2 \cdot 10^{-5}$ mbar-l/s (He). It can be used with operating pressures of up to 630 bar and is available with various threads.

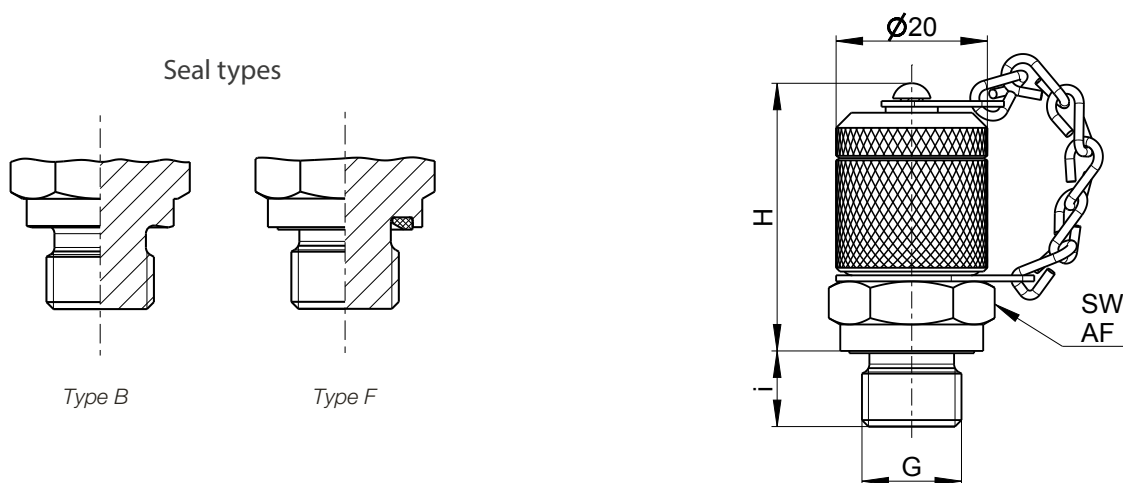

Thread	Seal type ¹	Technical specifications					Material: 1.4104 Stainless steel	Material: 1.4571 Stainless steel
		M ² Nm	p _n ³ bar	H mm	i mm	AF mm	Part No. with metal cap & FKM seals	Part No. with metal cap & FKM seals
Metric ISO thread								
M12 x 1.5	F	45	630	36	10	17	–	2402-01-13.50
M14 x 1.5	B	60	630	36	10	19	2402-01-49.00*	2402-01-49.30**
M14 x 1.5	F	60	630	36	10	19	2402-01-14.00	–
Whitworth thread								
ISO 228-G 1/4	F	60	630	36	10	19	2402-01-18.00	–
Operating temperature ranges: -20 °C ... 135 °C /* -33 °C ... 135 °C /** -46 °C ... 135 °C								
Additional versions, materials, and seal materials available upon request.								

¹ For detailed specifications regarding the seal types, please refer to pages 62 – 64

² M = Tightening torque for stud end in conformity with the applicable standards. It is the user's own responsibility to determine the appropriate installation torque for their specific installation situation.

³ p_n = Maximum operating pressure

Original MINIMESS® 1215 gas charging valve with DVGW certification

The original MINIMESS® 1215 DVGW gas charging valve can be used to establish a system access point for gas pressure regulating stations and connect control measuring devices for pressure measurement and gas sampling as specified in DVGW Code of Practice G 491, Section 5.7.1. It can be used with operating pressures of up to 250 bar and is characterized by a small coupling thread resulting in a very compact design and an extraordinary low gas leakage flow rate of less than $2 \cdot 10^{-5}$ mbar·l/s.

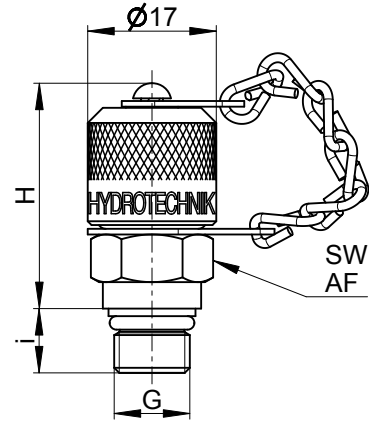

- I DVGW certification for:
Products for gas supply applications
- I Registration number: DG-4513BL0337
Certificate owner and distributor:
Hydrotechnik GmbH



Thread	Seal type ¹	Technical specifications					Material: 2.0371 Brass	Material: 1.4571 Stainless steel
		M ² Nm	p _n ³ bar	H mm	i mm	AF mm	Part No. with metal cap & NBR seals	Part No. with metal cap & NBR seals
G								
M10 x 1	G	15	250	30	8.5	14	2801-66-33.00	2701-66-33.00
Operating temperature range: -20 °C ... 70 °C								
Additional versions available upon request.								

¹ For detailed specifications regarding the seal types, please refer to pages 62 – 64

² M = Tightening torque for stud end in conformity with the applicable standards. It is the user's own responsibility to determine the appropriate installation torque for their specific installation situation.

³ p_n = Maximum operating pressure

Original MINIMESS® 1615 gas charging valve with accumulator adapter

The original MINIMESS® 1615 gas charging valve featuring an accumulator adapter can be used to directly install the valve on all popular bladder accumulators and can be used with operating pressures of up to 400 bar.

This gas charging valve makes it possible to safely charge and empty accumulators with an extremely low leakage flow rate.

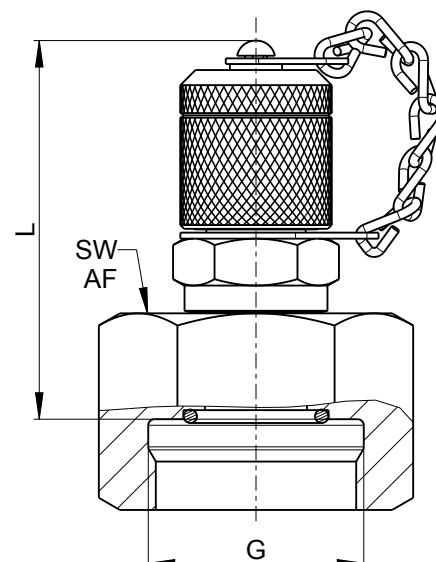

Female thread	Technical specifications			Material:
	p_n^1 bar	L mm	AF mm	Gas charging valve: 1.4104 stainless steel Accumulator adapter: 1.0718 free cutting steel
G				Part No. FKM seals
7/8-14 UNF	400	59.3	30	2446-16-30.00
M28 x 1.5	400	50.6	36	2446-18-30.00
Operating temperature range: -25 °C ... 100 °C				
Additional versions, materials, and seal materials available upon request.				

¹ p_n = Maximum operating pressure

MINIMESS® accumulator charging and testing device

The MINIMESS® accumulator charging and testing device can be used to charge and test multiple accumulators without having to close the pressure source (usually a nitrogen cylinder).

The pressure in the charging and testing device can be relieved after closing the nitrogen cylinder by opening the relief valve.

In contrast to devices for which the pressure source needs to be closed after every charging operation, the MINIMESS® accumulator charging and testing device can be used to charge or test multiple accumulators, saving time and cutting costs as a result.



Gas charging and testing device with pressure regulator

Premium quality. Made in Germany. For charging, adjusting, and monitoring gas pressures in nitrogen hydraulic accumulators and featuring pressure gauges with a diameter of 63 mm and accuracy class 1.6.



Secondary pressure setting bar	Primary pressure setting bar	Cylinder connection thread	Secondary connection	AF mm	Part No.
10 – 235	0 – 250	W 24.32 x 1/14"	MINIMESS® 1615	28	5401-02-00.00
10 – 235	0 – 250	W 21.8 x 1/14"	MINIMESS® 1615	28	5401-02-02.00
0 – 1.3	0 – 1.6	W 24.32 x 1/14"	MINIMESS® 1615	28	5401-07-00.00

Adapter options with original MINIMESS® test points

Special installation situations, grouping together multiple measuring points at a central location, or retrofitting into existing systems – all child's play with the various fitting and adapter options for MINIMESS® test points.

Adapter option examples:

- I Combi fitting tees make it possible to retrofit or install MINIMESS® test points on hydraulic system pipes and hose lines. They have a 360° swivel range, meaning that they can adapt optimally to an extremely broad range of installation conditions.
Combi fitting tees are available with 24° sealing cone and O-ring (DKO) connections in conformity with ISO 8434-1 as standard.
Upon request, versions with a 37° flared fitting in conformity with ISO 8434-2, with an ORFS connector as per ISO 8434-3, or with a 60° cone as per ISO 8434-6 are available.
- I MINIMESS® bulkhead test points can be used, for example, to group together multiple test points at an easily accessible location, making maintenance easier as a result.



Original MINIMESS® 1620 test point with DKO fitting

MINIMESS® test points with fittings for 24° sealing cone fittings with an O-ring make it possible to easily use the test points in systems with sealing cone connections that conform to DIN 2353 / ISO 8434-1.

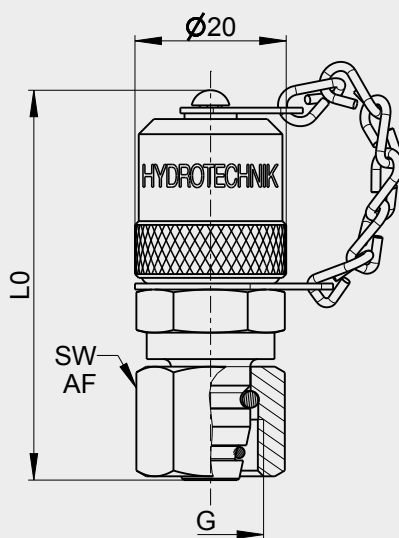

Figure 1

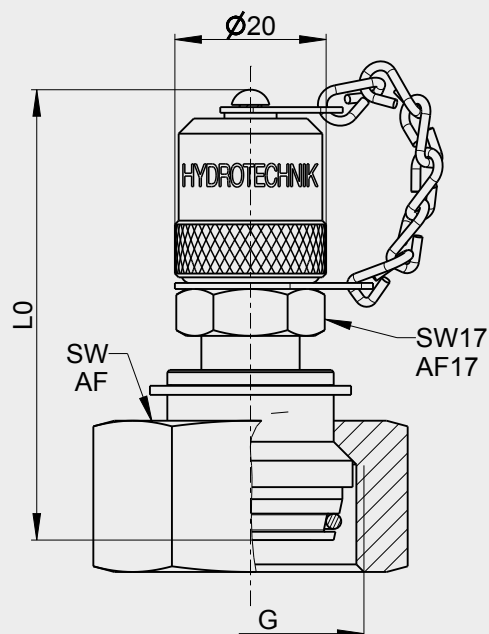
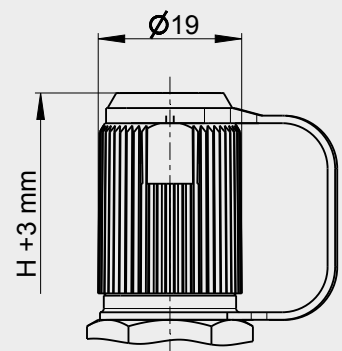

Figure 2



Version with plastic cap

Series	Thread	Technical specifications			Material: 1.0718	Material: 1.4571
		p_n^1 bar	L0 mm	AF mm	free cutting steel Part No. with metal cap & NBR seals ²	Stainless steel Part No. with metal cap & FKM seals
Light series, designed in conformity with					Figure 1	Figure 2
L 6	M12 x 1.5	315	52	14	2103-93-06.00N	2703-40-06.10
L 8	M14 x 1.5	315	52	17	2103-93-08.00N	2703-40-08.10
L 10	M16 x 1.5	315	52	19	2103-93-10.00N	2703-40-10.10
L 12	M18 x 1.5	315	52	22	2103-93-12.00N	2703-40-12.10
L 15	M22 x 1.5	315	52	27	2103-93-15.00N	2703-40-15.10
L 18	M26 x 1.5	315	52	32	2103-93-18.00N	2703-40-18.10
Light series, designed in conformity with					Figure 2	
L 22	M30 x 2	160	60	36	2103-40-22.00N	–
L 28	M36 x 2	160	61	41	2103-40-28.00N	–
L 35	M45 x 2	160	63	50	2103-40-35.00N	–
L 42	M52 x 2	160	63	60	2103-40-42.00N	–
Heavy series, designed in conformity with					Figure 1	Figure 2
S 6	M14 x 1.5	630	52	17	2103-94-06.00N	–
S 8	M16 x 1.5	630	52	19	2103-94-08.00N	2703-41-08.10
S 10	M18 x 1.5	630	52	22	2103-94-10.00N	2703-41-10.10
S 12	M20 x 1.5	630	52	24	2103-94-12.00N	2703-41-12.10
S 16	M24 x 1.5	400	52	30	2103-94-16.00N	2703-41-16.10
Heavy series, designed in conformity with					Figure 2	
S 14	M22 x 1.5	630	63	27	2103-41-14.00N	–
S 20	M30 x 2	400	63	36	2103-41-20.00N	2703-41-20.10
S 25	M36 x 2	400	64.5	46	2103-41-25.00N	2703-41-20.10
S 30	M42 x 2	400	66	50	2103-41-30.00N	–
S 38	M52 x 2	400	69	60	2103-41-38.00N	2703-41-38.10
Options						
Part No. with FKM seals					XXXX-XX-XX.10N	–
Part No. with plastic cap					XXXX-XX-XX.90N	–
Part No. with plastic cap & FKM seals					XXXX-XX-XX.95N	XXXX-XX-XX.95

¹ p_n = Maximum operating pressure

² Seal on DKO fitting made of FKM

Operating temperature ranges: With NBR seals: -25 °C ... 100 °C / With FKM seals: -20 °C ... 200 °C / With plastic cap: Max. 100 °C

Additional versions, materials, and seal materials available upon request.

Original MINIMESS® 1615 test point with DKO fitting

MINIMESS® test points with fittings for 24° sealing cone fittings with an O-ring make it possible to easily use the test points in systems with sealing cone connections that conform to DIN 2353 / ISO 8434-1.

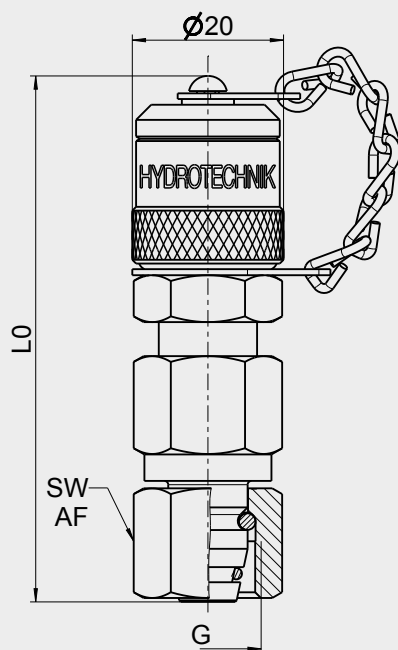

Figure 1

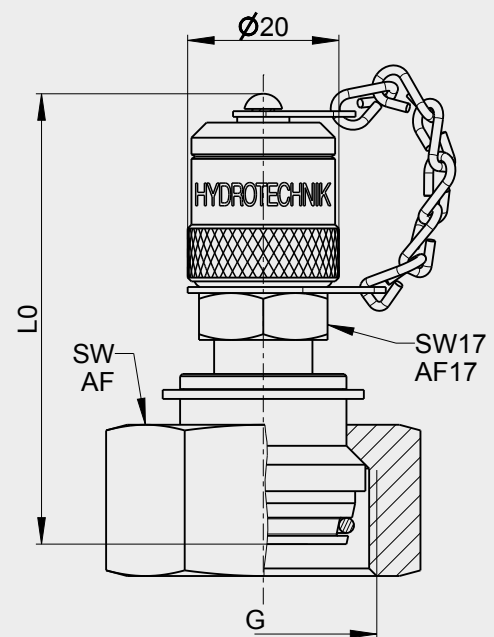

Figure 2

Series	Thread	Technical specifications			Material: 1.0718 free cutting steel Part No. with metal cap & NBR seals ²	
		Ø D	G	p _n ¹ bar		L0 mm
Light series, designed in conformity with figure 1						
L 6	M12 x 1.5		315	69.5	14	2102-40-06.00N
L 8	M14 x 1.5		315	69.5	17	2102-40-08.00N
L 10	M16 x 1.5		315	69.5	19	2102-40-10.00N
L 12	M18 x 1.5		315	69.5	22	2102-40-12.00N
Light series, designed in conformity with figure 2						
L 15	M22 x 1.5		315	59	27	2102-40-15.00N
Heavy series, designed in conformity with figure 1						
S 8	M16 x 1.5		630	69.5	19	2102-41-08.00N
S 12	M20 x 1.5		630	69.5	24	2102-41-12.00N
Heavy series, designed in conformity with figure 2						
S 14	M22 x 1.5		630	62.5	27	2102-41-14.00N
S 16	M24 x 1.5		400	62.5	30	2102-41-16.00N
S 20	M30 x 2		400	63	36	2102-41-20.00N
S 25	M36 x 2		400	64.5	46	2102-41-25.00N
Options						
Part No. with FKM seals						XXXX-XX-XX.10N

¹ p_n = Maximum operating pressure

² Seal on DKO fitting made of FKM

Operating temperature ranges: With NBR seals: -25 °C ... 100 °C / With FKM seals: -20 °C ... 200 °C

Additional versions, materials, and seal materials available upon request.

Original MINIMESS® 1215 test point with DKO fitting

MINIMESS® test points with fittings for 24° sealing cone fittings with an O-ring make it possible to easily use the test points in systems with sealing cone connections that conform to DIN 2353 / ISO 8434-1.

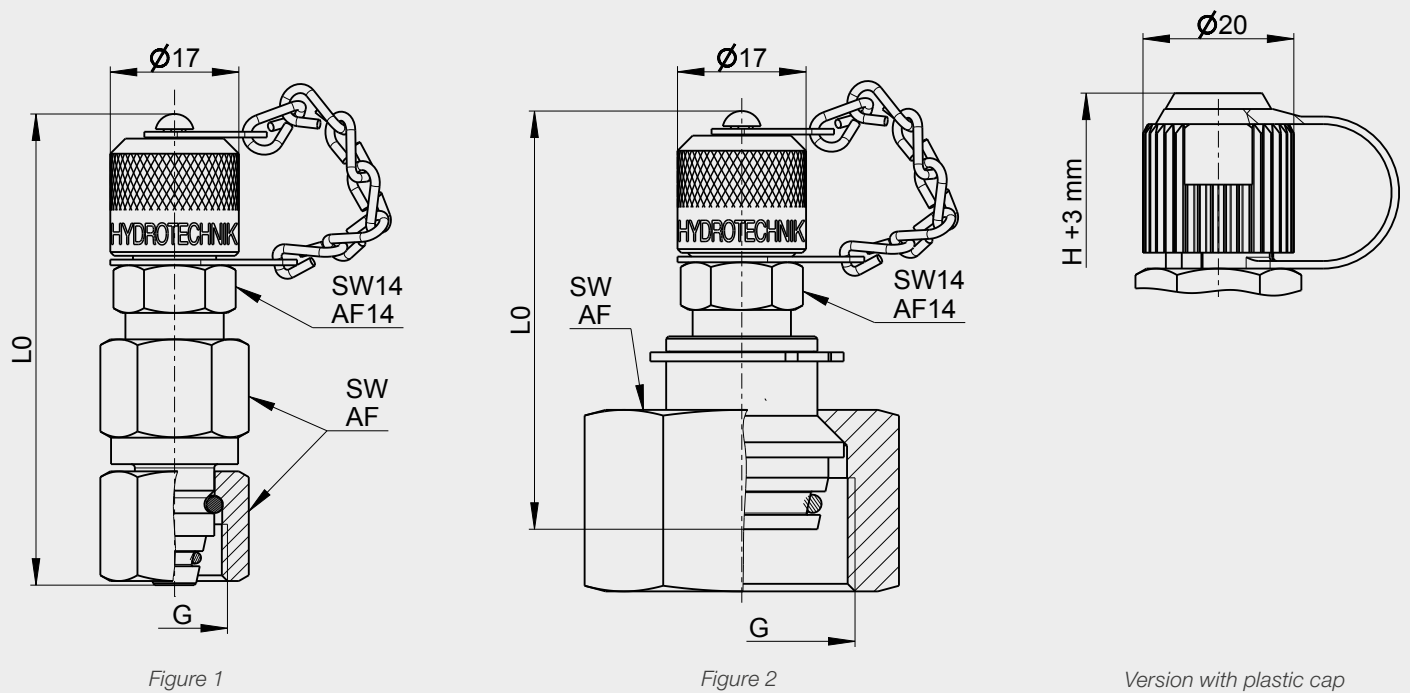

Series	Thread	Technical specifications			Material: 1.0718 free cutting steel
Ø D	G	p _n ¹ bar	L0 mm	AF mm	Part No. with metal cap & NBR seals ²
Light series, designed in conformity with figure 1					
L 6	M12 x 1.5	315	62	17	2101-40-06.90N
L 8	M14 x 1.5	315	51.5	19	2101-93-08.90N
L 10	M16 x 1.5	315	51.5	19	2101-93-10.90N
L 12	M18 x 1.5	315	62	22	2101-40-12.90N
Light series, designed in conformity with figure 2					
L 15	M22 x 1.5	315	51.5	27	2101-93-15.90N
L 18	M26 x 1.5	315	52.5	32	2101-40-18.90N
Heavy series, designed in conformity with figure 1					
S 6	M14 x 1.5	630	62	17	2101-41-06.90N
S 8	M16 x 1.5	630	51.5	19	2101-94-08.90N
S 10	M18 x 1.5	630	51.5	22	2101-94-10.90N
S 12	M20 x 1.5	630	58	24	2101-94-12.90N
Heavy series, designed in conformity with figure 2					
S 14	M22 x 1.5	630	55	27	2101-41-14.90N
S 16	M24 x 1.5	400	55	30	2101-41-16.90N
S 20	M30 x 2	400	55.5	36	2101-41-20.90N
Options					
Part No. with plastic cap and FKM seals					XXXX-XX-XX.10N
Part No. with plastic cap and NBR seals					XXXX-XX-XX.00N

¹ p_n = Maximum operating pressure

² Seal on DKO fitting made of FKM

Operating temperature ranges: With NBR seals: -25 °C ... 100 °C / With FKM seals: -20 °C ... 200 °C / With plastic cap: Max. 100 °C

Additional versions, materials, and seal materials available upon request.

Original MINIMESS® 1620 test point with DKO combi fitting tee

MINIMESS® test points with 24° sealing cone and O-ring combi fitting tees can be easily retrofitted and used on existing systems with sealing cone connections that conform to DIN 2353 / ISO 8434-1.

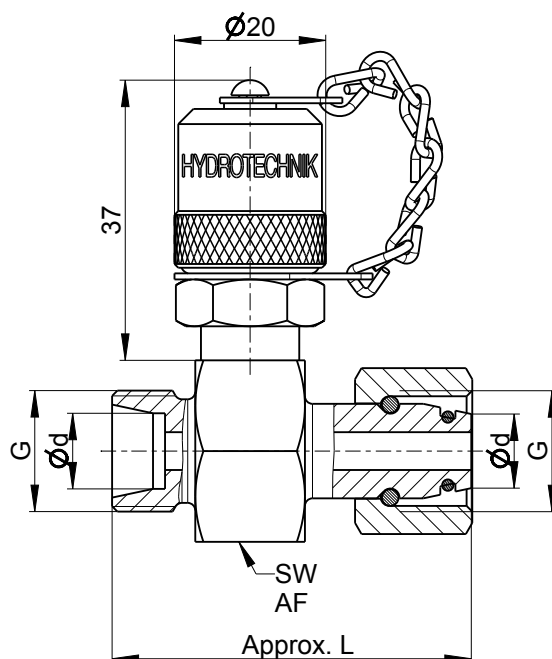

Series	Thread	Technical specifications				Material: 1.0718 free cutting steel Part No. with metal cap & NBR seals ²
Ø D	G	p _n ¹ bar	L ₀ mm	L mm	AF mm	
Light series version						
L 6	M12 x 1.5	315	49	44.5	24	2103-KL-10.06N
L 8	M14 x 1.5	315	49	44.5	24	2103-KL-08.00N
L 10	M16 x 1.5	315	49	47.5	24	2103-KL-10.00N
L 12	M18 x 1.5	315	49	48.5	24	2103-KL-12.00N
L 15	M22 x 1.5	315	52	51.5	30	2103-KL-15.00N
L 18	M26 x 1.5	315	53	55.5	32	2103-KL-18.00N
L 22	M30 x 2	160	22	58.5	36	2103-KL-22.00N
Heavy series version						
S 8	M16 x 1.5	630	49	48.5	24	2103-KS-08.00N
S 10	M18 x 1.5	630	49	49.5	24	2103-KS-10.00N
S 12	M20 x 1.5	630	50.5	50.5	27	2103-KS-12.00N
S 14	M22 x 1.5	630	51	53.5	27	2103-KS-14.00N
S 16	M24 x 1.5	400	52	56.5	30	2103-KS-16.00N
S 20	M30 x 2	400	55	64.5	36	2103-KS-20.00N
S 25	M36 x 2	400	57.5	66	41	2103-KS-25.00N

¹ p_n = Maximum operating pressure

² Seal on DKO fitting made of FKM

Operating temperature range: -25 °C ... 100 °C

Additional versions, materials, and seal materials available upon request. DKO combination fitting with test points from the 1615 or 1604 series available upon request.

Original MINIMESS® 1620 test point with tee adapter

MINIMESS® test points with a tee adapter can be easily retrofitted and used on existing piping systems as a result of a cutting ring fitting that conforms to DIN 2353 / ISO 8434-1.

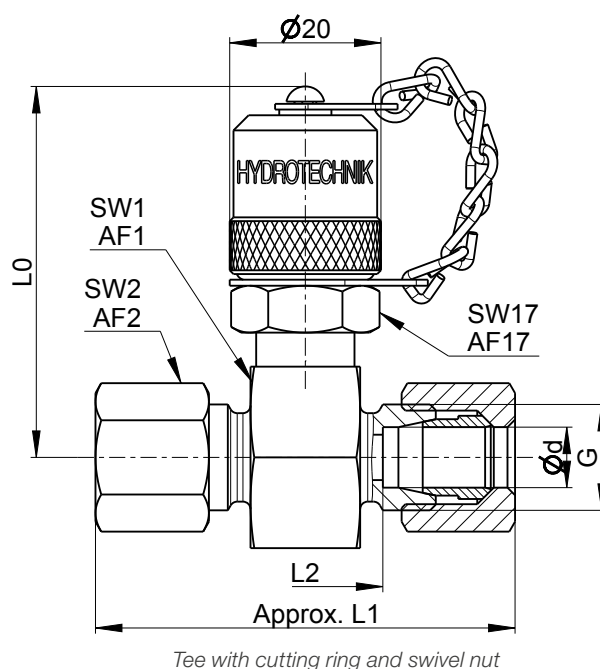

Series	Thread	Technical specifications						Material: 1.0718 free cutting steel Version: With metal cap & NBR seals	
		p_n^1 bar	L0 mm	L1 mm	L2 mm	SW1 mm	SW2 mm	Part No. with cutting ring and swivel nut	Part No. without cutting ring and swivel nut
Light series version									
L 6	M12 x 1.5	315	49.5	50.5	20.5	24	14	2103-11-06.00N	2103-11-06.05N
L 8	M14 x 1.5	315	49.5	50.5	20.5	24	17	2103-11-08.00N	2103-11-08.05N
L 10	M16 x 1.5	315	49.5	52.5	22.5	24	19	2103-11-10.00N	2103-11-10.05N
L 12	M18 x 1.5	315	49.5	52.5	22.5	24	22	2103-11-12.00N	2103-11-12.05N
L 15	M22 x 1.5	315	52.5	54.5	24.5	30	27	2103-11-15.00N	2103-11-15.05N
L 18	M26 x 1.5	315	53.5	56.5	23.5	32	32	2103-11-18.00N	2103-11-18.05N
L 22	M30 x 2	160	55.5	60.5	27.5	36	36	2103-11-22.00N	2103-11-22.05N
L 28	M30 x 2	160	58	60.5	27.5	41	41	2103-11-28.00N	2103-11-28.05N
Heavy series version									
S 6	M14 x 1.5	630	49.5	54.5	24.5	24	17	2103-12-06.00N	2103-12-06.05N
S 8	M16 x 1.5	630	49.5	54.5	24.5	24	19	2103-12-08.00N	2103-12-08.05N
S 10	M18 x 1.5	630	49.5	56.5	23.5	24	22	2103-12-10.00N	2103-12-10.05N
S 12	M20 x 1.5	630	49.5	56.5	23.5	24	24	2103-12-12.00N	2103-12-12.05N
S 14	M22 x 1.5	630	51	62.5	26.5	27	27	2103-12-14.00N	2103-12-14.05N
S 16	M24 x 1.5	400	52.5	62.5	25.5	30	30	2103-12-16.00N	2103-12-16.05N
S 20	M30 x 2	400	55.5	68.5	25.5	36	36	2103-12-20.00N	2103-12-20.05N
S 25	M36 x 2	400	58	74.5	26.5	41	46	2103-12-25.00N	2103-12-25.05N

¹ p_n = Maximum operating pressure

Operating temperature range: -25 °C ... 100 °C

Additional versions, materials, and seal materials available upon request. Tees with test points from the 1615 or 1604 series available upon request.

Original MINIMESS® 1215 test point with DKO combi fitting tee

MINIMESS® test points with 24° sealing cone and O-ring combi fitting tees can be easily retrofitted and used on existing systems with sealing cone connections that conform to DIN 2353 / ISO 8434-1.

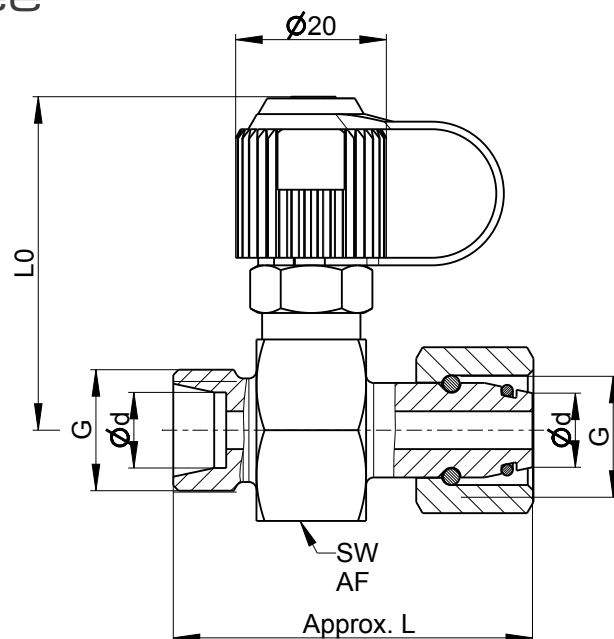

Series	Thread	Technical specifications				Material: 1.0718 free cutting steel Part No. with plastic cap & NBR seals ²
Ø D	G	p _n ¹ bar	L0 mm	L mm	AF mm	
Light series version						
L 6	M12 x 1.5	315	45	44.5	24	2101-KL-06.00N
L 8	M14 x 1.5	315	45	44.5	24	2101-KL-08.00N
L 10	M16 x 1.5	315	45	47.5	24	2101-KL-10.00N
L 12	M18 x 1.5	315	45	48.5	24	2101-KL-12.00N
L 15	M22 x 1.5	315	48	51.5	30	2101-KL-15.00N
L 18	M26 x 1.5	315	49	55.5	32	2101-KL-18.00N
L 22	M30 x 2	160	51	58.5	36	2101-KL-22.00N

¹ p_n = Maximum operating pressure

² Seal on DKO fitting made of FKM

Operating temperature range: -25 °C ... 100 °C

Additional versions, materials, and seal materials available upon request. DKO combination fitting with test points from the 1615 or 1604 series available upon request.

Original MINIMESS® 1215 test point with tee adapter

MINIMESS® test points with a tee adapter can be easily retrofitted and used on existing piping systems as a result of a cutting ring fitting that conforms to DIN 2353 / ISO 8434-1.

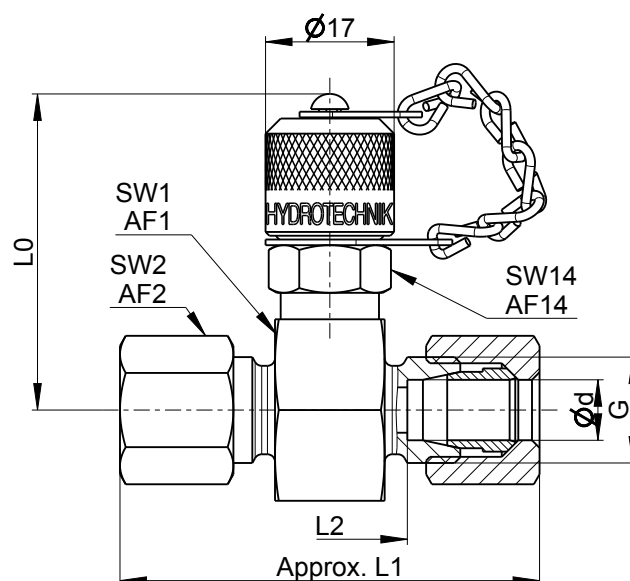

Series	Thread	Technical specifications						Material: 1.0718 free cutting steel	
Ø D	G	p _n ¹ bar	L0 mm	L1 mm	L2 mm	SW1 mm	SW2 mm	Part No. with metal cap & NBR seals	
Light series version									
L 6	M12 x 1.5	315	42	50.5	20.5	24	14	2101-11-06.90N	
L 8	M14 x 1.5	315	42	50.5	20.5	24	17	2101-11-08.90N	
L 10	M16 x 1.5	315	42	52.5	22.5	24	19	2101-11-10.90N	
L 12	M18 x 1.5	315	42	52.5	22.5	24	22	2101-11-12.90N	
L 15	M22 x 1.5	315	45	54.5	24.5	30	27	2101-11-15.90N	
L 18	M26 x 1.5	315	46	56.5	23.5	32	32	2101-11-18.90N	
L 22	M30 x 2	160	48	60.5	27.5	36	36	2101-11-22.90N	
L 28	M36 x 2	160	50.5	60.5	27.5	41	41	2101-11-28.90N	
Heavy series version									
S 6	M14 x 1.5	630	42	54.5	24.5	24	17	2101-12-06.90N	
S 8	M16 x 1.5	630	42	54.5	24.5	24	19	2101-12-08.90N	
S 10	M18 x 1.5	630	42	56.5	23.5	24	22	2101-12-10.90N	
S 12	M20 x 1.5	630	42	56.5	23.5	24	24	2101-12-12.90N	
S 14	M22 x 1.5	630	43.5	62.5	26.5	27	27	2101-12-14.90N	
S 16	M24 x 1.5	400	45	62.5	25.5	30	30	2101-12-16.90N	
S 20	M30 x 2	400	48	68.5	25.5	36	36	2101-12-20.90N	
S 25	M36 x 2	400	50.5	74.5	26.5	41	46	2101-12-25.90N	

¹ p_n = Maximum operating pressure

Operating temperature range: -25 °C ... 100 °C

Additional versions, materials, and seal materials available upon request. Tees with test points from the 1615 or 1604 series available upon request.

Original MINIMESS® test point with 90° swivel fitting.

The swivel fitting makes it possible to adjust the test point position exactly as required for installation. In fact, the MINIMESS® can swivel 360° about the hole axis, making it easy to position it optimally.

A DKA sealing ring is used for sealing at the thread (banjo bolt).

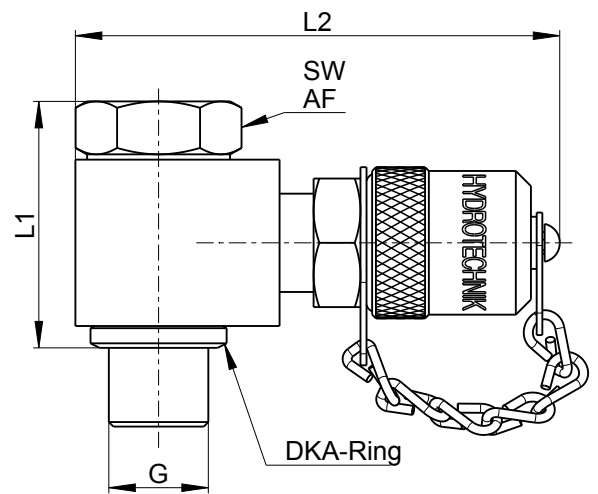

Thread		Technical specifications			Material: 1.0718 free cutting steel
G	p_n^1 bar	L1 mm	L2 mm	AF mm	Part No. with metal cap & NBR seals
MINIMESS® 1620					
ISO 228-G 1/4	630	34.5	64.5	19	2115-22-34.00N
MINIMESS® 1615					
ISO 228-G 1/4	630	34.5	69.5	19	2115-22-24.00N
MINIMESS® 1215					
ISO 228-G 1/4	630	34.5	46	19	2115-22-14.00N
Options					
Part No. with FKM seals					XXXX-XX-XX.10N

¹ p_n = Maximum operating pressure

Operating temperature ranges: With NBR seals: -25 °C ... 100 °C / With FKM seals: -20 °C ... 200 °C

Additional versions, materials, and seal materials available upon request.

Original MINIMESS® 1620 bulkhead test point

MINIMESS® bulkhead test points can be used to group together multiple measuring points at a central system servicing point. This results in significantly easier maintenance when used to replace a large number of test points that are difficult to access.

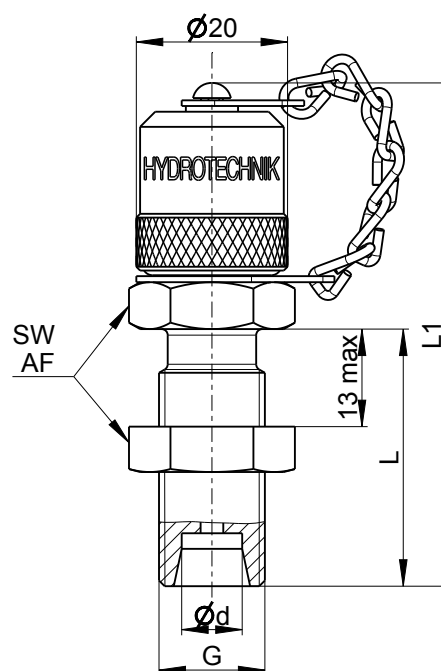

Series	Thread	Technical specifications				Material: 1.0718 free cutting steel Part No. with metal cap & NBR seals
Ø D	G	p _n ¹ bar	L mm	L1 mm	AF	
Light series version						
L 6	M12 x 1.5	315	34	67	17	2103-04-22.00N
L 8	M14 x 1.5	315	34	67	19	2103-04-23.00N
L 10	M16 x 1.5	315	33.5	66.5	22	2103-04-18.00N
Heavy series version						
S 6	M14 x 1.5	630	36	69	19	2103-04-24.00N
S 8	M16 x 1.5	630	33.5	66.5	22	2103-04-25.00N
S 10	M18 x 1.5	630	37	70	24	2103-04-26.00N

¹ p_n = Maximum operating pressure

Operating temperature range: -25 °C ... 100 °C

Additional versions, materials, and seal materials available upon request. 1215, 1615, and 1604 series bulkhead test points available upon request.

Original MINIMESS® bulkhead test points with MINIMESS® connection on both sides.

Bulkhead test points with a MINIMESS® connection on both sides can be used to group together multiple measuring points at a central system servicing point by using MINIMESS® hose lines.

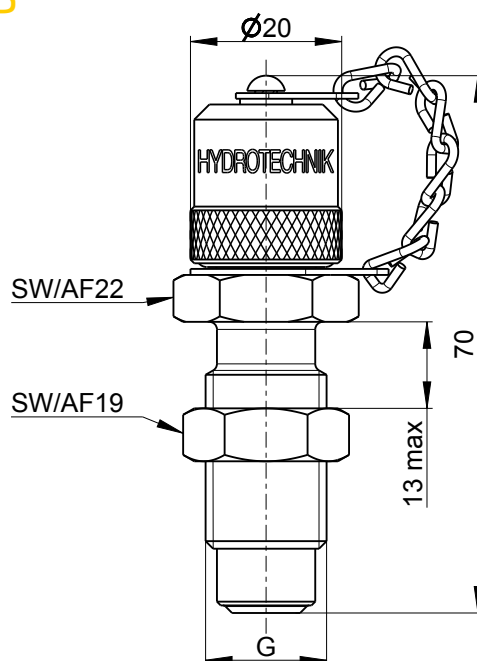

Connection	Thread		Material: 1.0718 free cutting steel Part No. with metal cap & NBR seals
MINIMESS® 1620 on both sides	M16 x 2	p_n^1 bar	2103-04-16.00N
MINIMESS® 1615 on both sides	M16 x 1.5	630	2102-04-01.00N

¹ p_n = Maximum operating pressure

Operating temperature range: -25 °C ... 100 °C

Original MINIMESS® 1620 test point with 37° flared fitting

MINIMESS® test points with a connection for a 37° flared fitting in conformity with SAE J514 can be used for direct connections to compatible pipes.

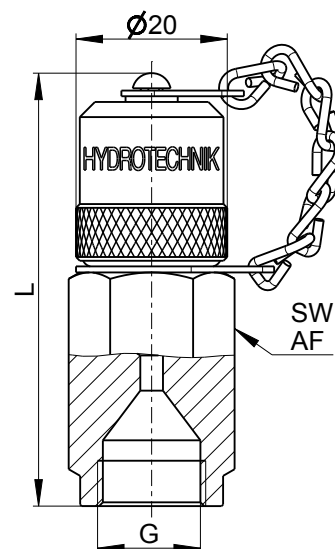

Thread		Technical specifications				Material: 1.0718 free cutting steel		
G	p_n^1 bar	Pipe diameter mm	Pipe diameter Inches	L mm	AF mm	Part No. with metal cap & NBR seals		
7/16-20 UNF	630	6	1/4	55	17	2103-85-21.00N		
9/16-18 UNF	315	10	3/8	57.5	19	2103-85-23.00N		
Options								
Part No. with FKM seals								XXXX-XX-XX.10N

¹ p_n = Maximum operating pressure

Operating temperature ranges: With NBR seals: -25 °C ... 100 °C / With FKM seals: -20 °C ... 200 °C

Additional versions, materials, and seal materials available upon request.

Original MINIMESS® 1620 test point with ORFS fitting

MINIMESS® test points with a connection for ORFS fittings in conformity with ISO 8434-3 / SAE J1453-1 can be used for direct connections to compatible ORFS fittings.

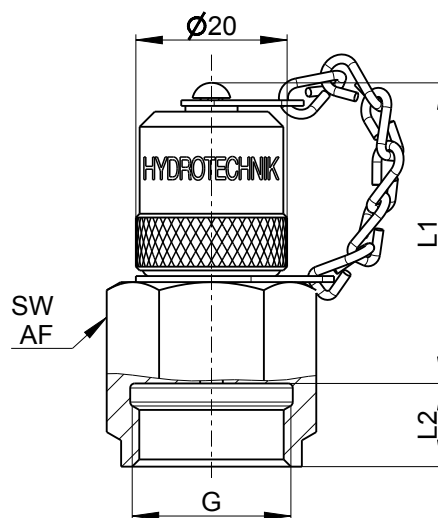

Thread	Technical specifications				Material: 1.0718 free cutting steel Part No. with metal cap & NBR seals
G	p_n^1 bar	L1 mm	L2 mm	AF mm	
9/16-18 UNF	630	40	8	17	2103-56-10.00N
11/16-16 UN	630	40	9	22	2103-56-12.00N
13/16-16 UN	630	40	11	24	2103-56-14.00N
Options					
Part No. with FKM seals					XXXX-XX-XX.10N

¹ p_n = Maximum operating pressure

Operating temperature range: With NBR seals: -25 °C ... 100 °C / With FKM seals: -20 °C ... 200 °C

Additional versions, materials, and seal materials available upon request.

MINIMESS® direct pressure gauge and sensor adapter

The MINIMESS® direct pressure gauge and sensor adapter can be used to connect pressure sensors or gauges with various threads directly to the MINIMESS® test point.

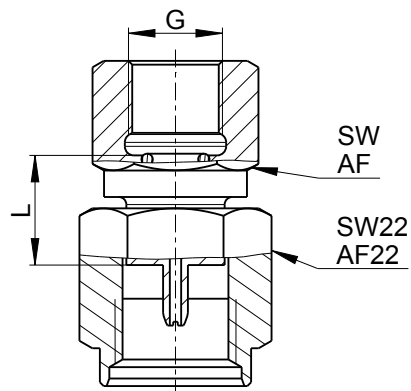

Thread	Technical specifications			Material: 1.0718	Material: 1.0718
	p_n^1 bar	L mm	AF mm	free cutting steel Part No. with pressure gauge adapter ²	free cutting steel Part No. with pressure sensor adapter
MINIMESS® 1620					
ISO 228-G 1/4	630	14.5	19	2103-07-11.62N	2103-07-18.62N
ISO 228-G 1/2	630	17	27	2103-07-12.62N	–
1/4 NPT	630	–	19	2103-07-23.62N	–
MINIMESS® 1615					
ISO 228-G 1/4	630	14.5	19	2102-07-11.62N	2102-07-18.62N
ISO 228-G 1/2	630	17	27	2102-07-12.62N	–
1/4 NPT	630	–	19	2102-07-23.62N	–
MINIMESS® 1215					
ISO 228-G 1/4	630	14.5	19	2101-07-11.62N	2101-07-18.62N
ISO 228-G 1/2	630	17	27	2101-07-12.62N	–
1/4 NPT	630	–	19	2101-07-23.62N	–
MINIMESS® 1604					
ISO 228-G 1/4	630	16.5	19	2106-07-11.62N	2106-07-18.62N

¹ p_n = Maximum operating pressure

² For connecting pressure gauges, a nozzle is additionally installed in the body and a sealing ring is enclosed.

Operating temperature range: -25 °C ... 100 °C

Additional versions and materials available upon request.

MINIMESS®

90° direct pressure gauge and sensor adapter

The MINIMESS® direct pressure gauge and sensor adapter featuring a 90° elbow connection can be used to directly connect pressure sensors or gauges even in challenging installation situations.

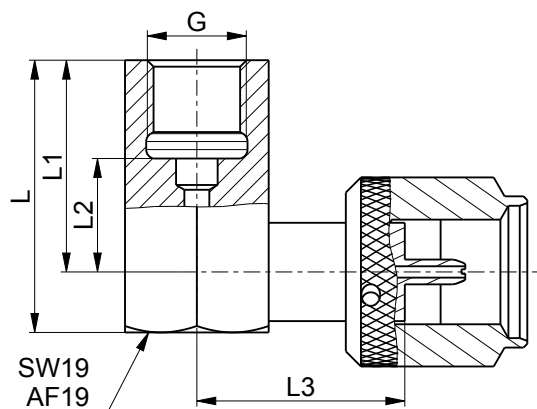

Thread		Technical specifications				Material: 1.0718 free cutting steel	
G	p_n^1 bar	L mm	L1 mm	L2 mm	L3 mm	Part No.	
MINIMESS® 1620							
ISO 228-G 1/4	630	36	28	15	27.5	2146-13-05.00N ²	
MINIMESS® 1215							
ISO 228-G 1/4	630	36	28	15	22.5	2146-14-02.00N ²	

¹ p_n = Maximum operating pressure

² Part number for use with pressure sensors. For connecting pressure gauges, a nozzle is additionally installed in the body and a sealing ring is enclosed. Part number available upon request.

Operating temperature range: -25 °C ... 200 °C

Additional versions and materials available upon request.

MINIMESS®

Direct pressure sensor adapter

The MINIMESS® direct pressure sensor adapter can be used to connect pressure sensors with a G 1/4 female thread to a MINIMESS® test point.

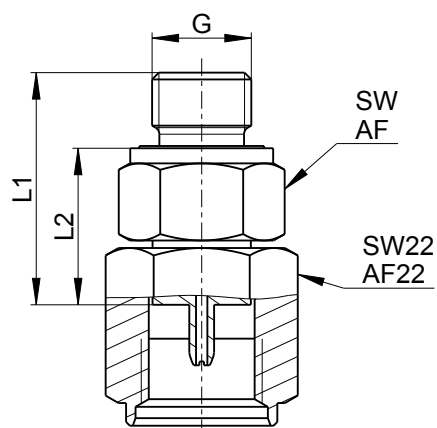

Thread	Technical specifications				Material: 1.0718 free cutting steel	
	p_n^1 bar	L1 mm	L2 mm	AF mm	Part No. with NBR seal	
MINIMESS® 1620						
ISO 228-G 1/4	630	30.7	20.7	19	2103-07-41.62N	
MINIMESS® 1615						
ISO 228-G 1/4	630	30.7	20.7	19	2102-07-41.62N	
MINIMESS® 1215						
ISO 228-G 1/4	630	33.5	23.5	19	2101-07-41.62N	

¹ p_n = Maximum operating pressure

Operating temperature range: -25 °C ... 100 °C

Additional versions and materials available upon request.

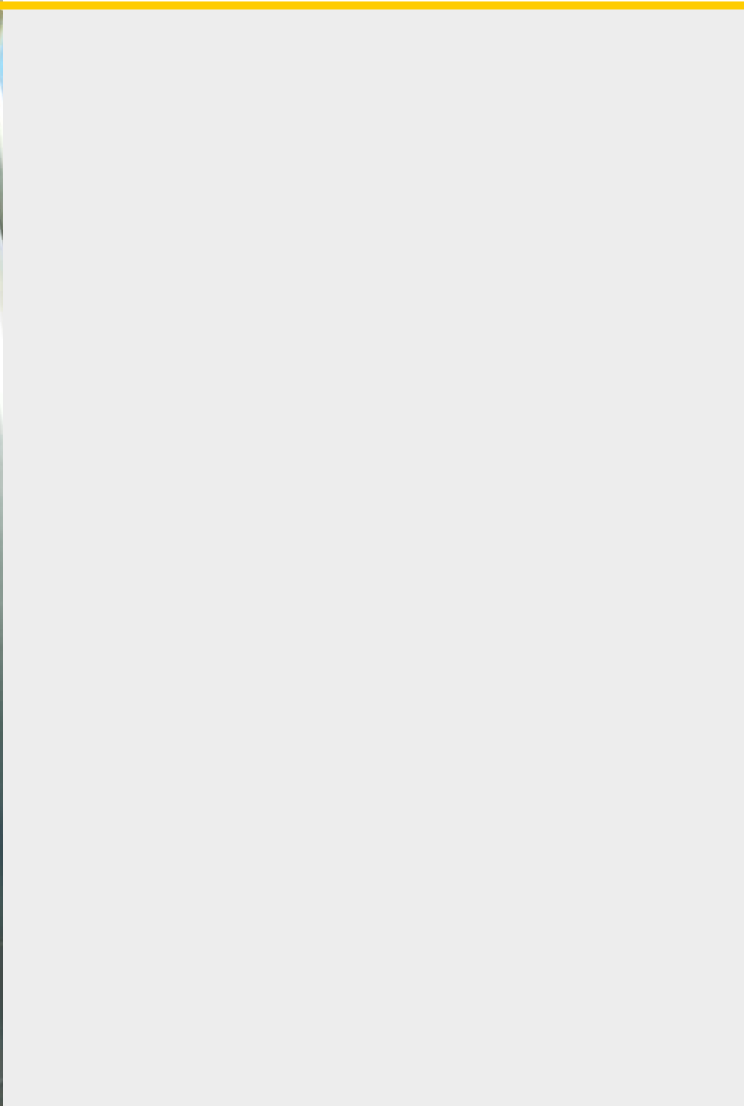

MINIMESS® Hose lines

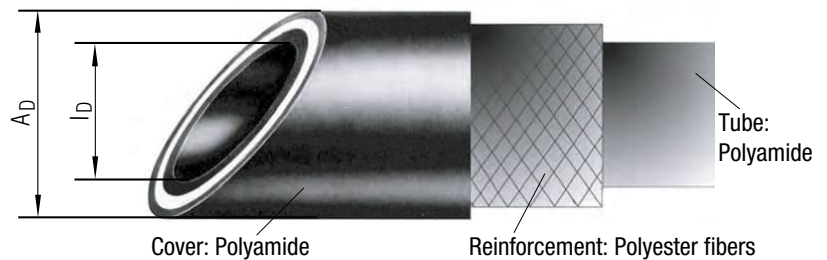

MINIMESS® hose lines make up an essential part of the MINIMESS® family of products. These hose lines have been developed specifically for high-pressure applications with pressures of up to 630 bar and are characterized by their resistance to aggressive fluids and a versatility that makes them ideal for use as control, diagnostic, and measuring hoses.

These hose lines can be used to conveniently group measuring points and route them to an easily accessible location in order to make maintenance and diagnostic activities easier.

They can then be combined with MINIMESS® bulkhead test points or pressure gauge connections for bulkheads so as to easily and quickly connect sensors or pressure gauges.

In addition to hose lines for standard hydraulic applications, we offer a variety of additional alternatives, e.g., for low-temperature and gas applications.

MINIMESS® hose lines are crimped and tested at Hydrotechnik and make an undeniably compelling case with their high quality and long service life.

Nominal diameter	Version	p_n^* bar	p_{dyn}^* bar	dp/dt bar/s	I_D mm	A_D mm	r_{min} mm	t_n °C
DN2	Standard 400, pin-pricked	400	300	3,900	2	4.9	20	-20 ... 100
DN2	Standard 630, pin-pricked	630	500	6,300	2	4.9	20	-20 ... 100
DN2	Low temperature, pin-pricked	630	500	6,300	2	4.9	20	-54 ... 100
DN4	Standard 315, pin-pricked	315	240	3,120	4	8	40	-20 ... 100
DN4	Standard 450, pin-pricked	450	340	4,420	4	8	40	-20 ... 100

- p_n = Maximum operating pressure
- p_{dyn} = Maximum operating pressure for dynamic applications
- dp/dt = Maximum permissible pressure rise time
- I_D = Inside diameter
- O_D = Outside diameter
- r_{min} = Smallest bend radius ($r_{min} \times 1.5$ at temperatures lower than -20 °C)
- t_n = Maximum operating temperature (briefly up to 120 °C)

* The hose line's maximum permissible operating pressure always corresponds to the pressure of the individual component with the lowest permissible operating pressure.

Part No. key for MINIMESS® hose lines

Fitting material	Position in Part No. S <u>XXX</u> – XX – XX – XXXXN
Code <u>1</u>	1.0718 free cutting steel
Code <u>2</u>	1.0718 free cutting steel EPDM seals for use with brake fluid
Code <u>7</u>	1.4571 stainless steel (the N ending in the part No. should be omitted in this case)

Hose version	Position in Part No. S <u>XXX</u> – XX – XX – XXXXN		
	Nominal diameter	p _n ¹	Version
Code <u>0</u>	DN2	400 bar	Standard hose, pin-pricked
Code <u>1</u>	DN2	630 bar	Standard hose, pin-pricked
Code <u>2</u>	DN2	630 bar	Low-temperature hose, pin-pricked
Code <u>5</u>	DN4	315 bar	Standard hose, pin-pricked
Code <u>6</u>	DN4	450 bar	Standard hose, pin-pricked

¹ p_n = Maximum operating pressure for measuring tasks

Important: The hose line's maximum permissible operating pressure always corresponds to the pressure of the individual component with the lowest permissible operating pressure.

Options	Position in Part No. S <u>XXX</u> – XX – XX – XXXXN
Code <u>0</u>	Standard version
Code <u>1</u>	Spring guard on left side
Code <u>2</u>	Spring guard on right side
Code <u>3</u>	Spring guards on both ends
Code <u>4</u>	Aluminum armor ²

Minimum hose length:
40 cm

² Aluminum armor cannot be combined with a spring guard.

Fitting version³ **Position in Part No.**
 S XXX – XX – XX – XXXXN

Left fitting



Right fitting

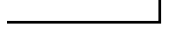

³For the fitting code, please refer to pages 50 – 57. The fitting code must be specified alphanumerically from left to right.

Hose length **Position in Part No.**
 S XXX – XX – XX – XXXXN

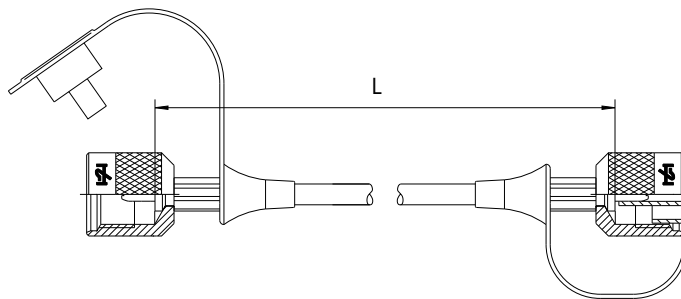

The hose length is the distance between the two fittings.

Specify the hose length in cm from left to right. Example: 50 cm = 0050

Part No. addition when specifying the fitting orientation:

Hoses with 90° fittings are usually assembled in such a way that the fittings will be pointing in the same direction and be aligned with each other.

If customers want a different fitting orientation, they must specify it explicitly.

Fitting orientation **Position in Part No.**
 S XXX XX XXX XX XXXXN

The angle is always measured counterclockwise and must be specified between the two fitting codes (in this case, hyphens should be completely omitted from the Part No.).

Order example for a hose line with DA fittings and a fitting orientation of 120°:
 S100DA120DA0100N

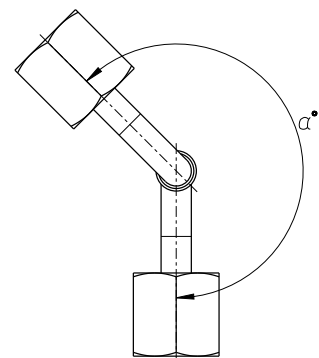

Fittings for MINIMESS® hose lines

MINIMESS® fitting

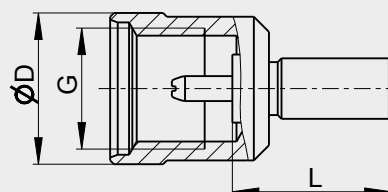

Nominal diameter	MINIMESS® fitting G	Technical specifications			Fitting code
		p_{n1} bar	$\varnothing D$ mm	L mm	
DN2	1215	630	20	22	AA
	1615	630	20	20	AB
	1620	630	20	20	AC
DN4	1215	630	20	35	AA
	1615	630	20	35	AB
	1620	630	20	35	AC
	1604	400	22	35	AD

MINIMESS® 90° fitting

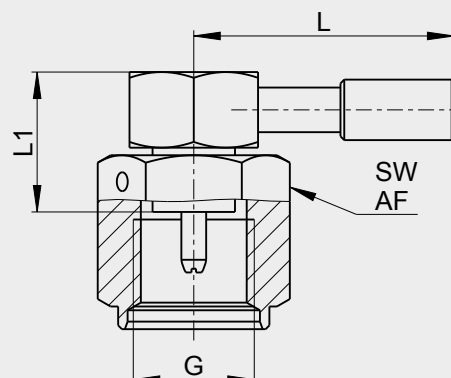

Nominal diameter	MINIMESS® fitting G	Technical specifications				Fitting code
		p_{n1} bar	AF mm	L mm	L1 mm	
DN2	1215	630	22	35.5	17.5	AJ
	1615	630	22	35.5	17.5	AK
	1620	630	22	35.5	17.5	AL

MINIMESS® fitting with check valve

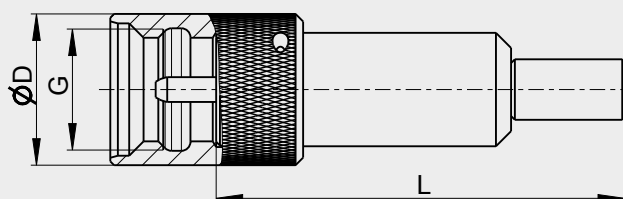

Nominal diameter	MINIMESS® fitting G	Technical specifications			Fitting code
		p_{n1} bar	$\varnothing D$ mm	L mm	
DN2	1620	630	20	50	AR
DN4	1604	400	24	70	AY

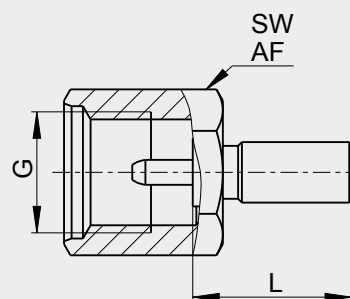

MINIMESS® fitting with hex swivel nut

Nominal diameter	MINIMESS® fitting G	Technical specifications				Fitting code
		p_{n1} bar	AF mm	L mm	L1 mm	
DN2	1215	630	19	38	22	AM
	1615	630	19	38	20	AN
	1620	630	19	38	20	A0

¹ p_{n1} = Maximum operating pressure

Fittings for MINIMESS® hose lines

Pressure gauge fitting as specified in DIN 16288 with
O-ring seal

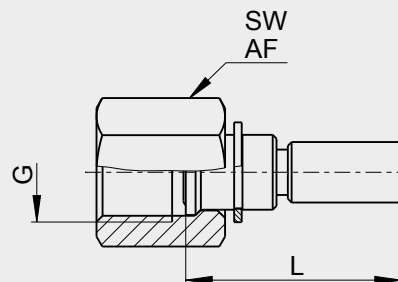

Nominal diameter	Thread G	Technical specifications			Fitting code
		p_n^1 bar	AF mm	L mm	
DN2	ISO 228-G 1/4	630	17	28.5	FG
	ISO 228-G 1/2	630	27	31.5	FH

DKO fitting – 24° sealing cone with O-ring in
conformity with ISO 8434-1

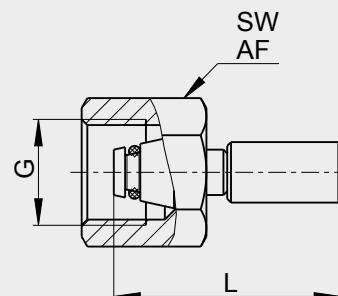

Nominal diameter	Series Ø D	Thread G	Technical specifications			Fitting code
			p_n^1 bar	AF mm	L mm	
Light series						
DN2/DN4	L 6	M12 x 1.5	315	14	30	CQ
	L 8	M14 x 1.5	315	17	34	CR
	L 10	M16 x 1.5	315	19	33.5	CS
	L 12	M18 x 1.5	315	22	33.5	CT
Heavy series						
DN2/DN4	S 6	M14 x 1.5	630	17	30	CU
	S 8	M16 x 1.5	630	19	34	CV
	S 10	M18 x 1.5	630	22	33.5	CW
	S 12	M20 x 1.5	630	24	33.5	CX

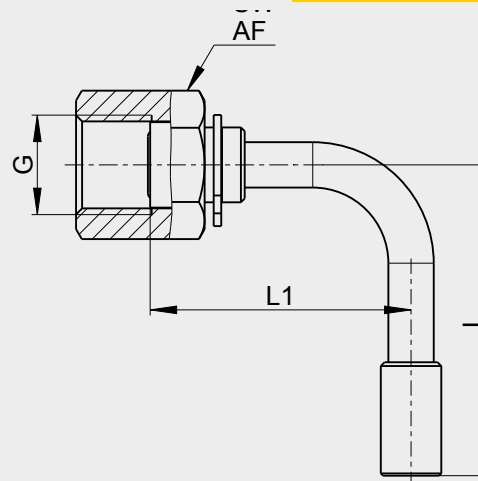

90° pressure gauge fitting as specified in DIN 16288
with O-ring seal

Nominal diameter	Thread G	Technical specifications				Fitting code
		p_n^1 bar	AF mm	L mm	L1 mm	
DN2	ISO 228-G 1/4	630	17	43.5	32	FI
	ISO 228-G 1/2	630	27	43	43	FJ

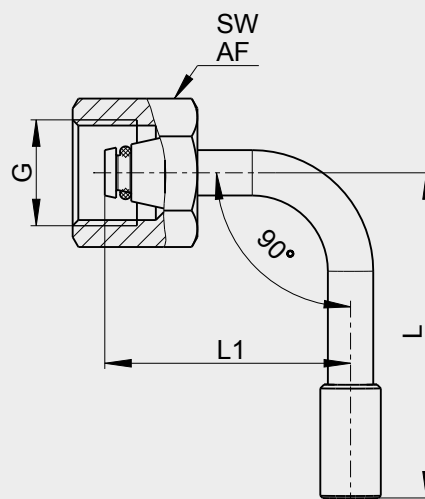

90° DKO fitting – 24° sealing cone with O-ring in
conformity with ISO 8434-1

Nominal diameter	Series Ø D	Thread G	Technical specifications				Fitting code
			p_n^1 bar	AF mm	L mm	L1 mm	
Light series							
DN2/DN4	L 6	M12 x 1.5	315	14	30	32.5	DA
	L 8	M14 x 1.5	315	17	34	32.5	DB
	L 10	M16 x 1.5	315	19	33.5	37.5	DC
	L 12	M18 x 1.5	315	22	33.5	37.5	DD
Heavy series							
DN2/DN4	S 6	M14 x 1.5	630	17	30	32.5	DE
	S 8	M16 x 1.5	630	19	34	32.5	DF
	S 10	M18 x 1.5	630	22	33.5	37.5	DG
	S 12	M20 x 1.5	630	24	33.5	37.5	DH

¹ p_n = Maximum operating pressure

Fittings for MINIMESS® hose lines

Tube stub for tube fitting in conformity with DIN 2353

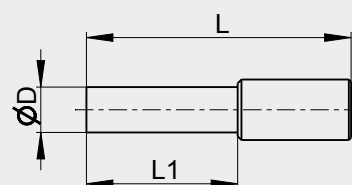

Nominal diameter	Technical specifications				Fitting code
	p_n^1 bar	$\emptyset D$ mm	L mm	L1 mm	
DN2	100	4	35	20	BA
	630	6	35	20	BB
	630	8	35	21	BC
	630	6.35	35	20	BD
DN4	630	6	48	20	BB
	630	8	47	21	BC

90° tube stub for tube fitting in conformity with DIN 2353

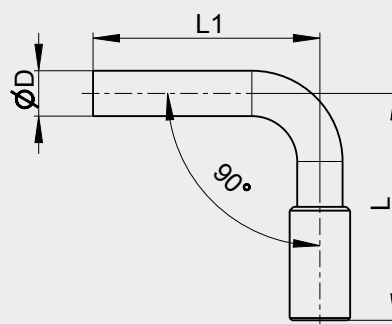

Nominal diameter	Technical specifications				Fitting code
	p_n^1 bar	$\emptyset D$ mm	L mm	L1 mm	
DN2	630	6	30	28	BG
DN4	630	6	48	25	BG

Nipple with male thread

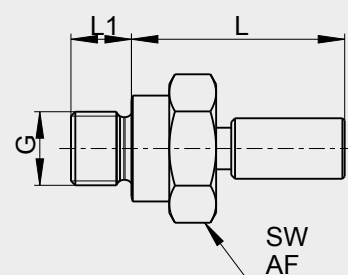

Nominal diameter	Thread	Technical specifications				Fitting code
		p_n^1 bar	AF mm	L mm	L1 mm	
DN2	ISO 228-G 1/8	400	14	26.5	8	GA

ORFS fitting

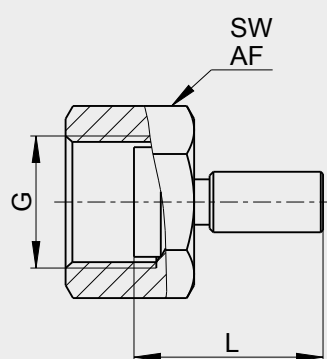

Nominal diameter	Thread	Technical specifications			Fitting code
		p_n^1 bar	AF mm	L mm	
DN2	11/16-16 UN	400	22	26.5	HC

¹ p_n = Maximum operating pressure

Fittings for MINIMESS® hose lines

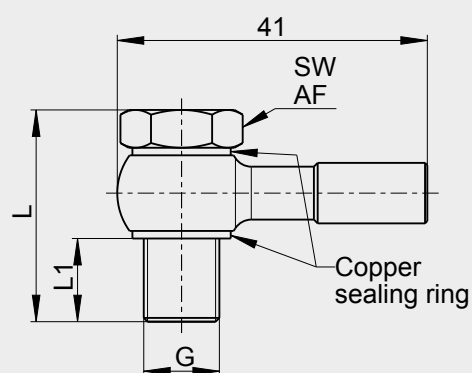

Banjo eye fitting with banjo bolt

Nominal diameter	Thread G	Technical specifications				Fitting code
		p_n^1 bar	AF mm	L mm	L1 mm	
DN2	M10 x 1	200	14	28	10	IA

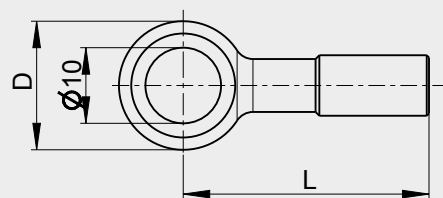

Banjo eye fitting as specified in DIN 7642 for M10 x 1 banjo bolt

Nominal diameter	Technical specifications			Fitting code
	p_n^1 bar	L mm	L1 mm	
DN2	200	41	17	IB
DN4	200	43.5	17	IB

¹ p_n = Maximum operating pressure

MINIMESS® pressure gauge and sensor adapter for bulkheads

The MINIMESS® direct pressure gauge and sensor adapter can be used to connect pressure sensors or gauges with MINIMESS® hose lines to a central system servicing point. This results in significantly easier monitoring and maintenance when used to replace a large number of test points or test points that are difficult to access.

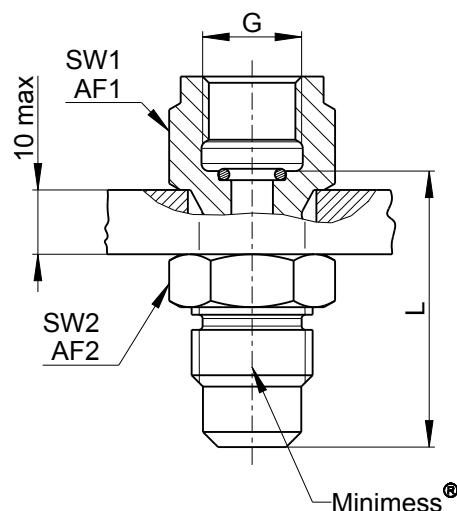

Thread		Technical specifications			Material: 1.0718 free cutting steel
G	p_n^1 bar	L mm	AF1 mm	AF2 mm	Part No. with NBR seal
MINIMESS® 1620					
ISO 228-G 1/4	630	38	19	19	2103-05-11.00N
ISO 228-G 1/2	630	42.5	27	19	2103-05-12.00N
1/4 NPT	630	–	19	19	2103-05-23.00N
MINIMESS® 1615					
ISO 228-G 1/4	630	38	19	19	2102-05-11.00N
ISO 228-G 1/2	630	42.5	27	19	2102-05-12.00N
MINIMESS® 1215					
ISO 228-G 1/4	630	29.5	19	19	2101-05-11.00N
ISO 228-G 1/2	630	42	27	19	2101-05-12.00N
1/4 NPT	630	–	22	24	2101-05-23.00N
MINIMESS® 1604					
ISO 228-G 1/4	630	40.5	22	24	2106-05-11.00N
ISO 228-G 1/2	630	44.5	27	24	2106-05-12.00N
Options					
Part No. with FKM seals					XXXX-XX-XX.10N

¹ p_n = Maximum operating pressure

Operating temperature ranges: With NBR seals: -25 °C ... 100 °C / With FKM seals: -20 °C ... 200 °C

Additional versions and materials available upon request.

Original MINIMESS® Minivalv

Maximum Damping. Minimum size.

The MINIMESS® Minivalv is an extremely compact throttle check valve that is typically installed in the hydraulic pilot line so as to restrict the flow at the directional control valve's outlet.

Its purpose is to make sure that poppet motion from or to the neutral position will always be damped so that the corresponding actuator will start up softly and in a controlled manner.

In contrast to a simple restrictor, the way in which this throttle check valve is built ensures that a vacuum cannot be produced at the intake. Moreover, the throttle check valve reduces the volumetric flow rate in one direction of flow and allows it to flow freely in the other. Depending on the desired flow rate, either a hole or a notch is used on the poppet in order to implement the reduced cross section.

Notched poppets are the preferred option for very small reduced cross sections, as they have a special advantage: Impurities that settle inside the notch can be easily flushed out when the direction of flow is reversed. For larger reduced cross sections, poppets with a hole are used instead, as they are more cost-effective.

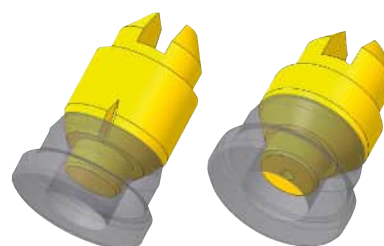

The MINIMESS® Minivalv throttle check valve

- | Is an effective and cost-effective solution that can be easily integrated and makes it possible to start actuators softly
- | Is ideal for places where space is tight, as it is no bigger than a standard nipple fitting
- | Is available with various orifice sizes and threads
- | Is highly resistant to corrosion (salt spray test longer than 1,000 hours)

Technical specifications

Operating pressure	– Up to max. 400 bar
Versions	– Restrictor hole diameter of 0.5 mm to 1.0 mm – Restrictor notch, equivalent to a restrictor hole diameter of 0.3 mm to 0.5 mm
Stud end	– 9/16-18 UNF, ISO 11927-2 – ISO 228-G 1/4, ISO 9974-2
Connector end	– 9/16-18 UNF, ISO 8434-3 – 11/16-16 UN, ISO 8434-3 – M14 x 1.5 8L, DIN 2353

Flat Face diagnostic coupling

The Flat Face system has won endless converts as a result of its compact design and the fact that the absence of a thread makes it easy to clean.

The diagnostic coupling is used in applications with hydraulic oils as operating medium, the coupling side conforms to ISO 15171-1, and the maximum operating pressure is 400 bar.

The Flat Face diagnostic coupling is highly resistant to corrosion and successfully passes a 1,000-hour salt spray test.



Test coupling for air brake systems

Coupling for testing initial delay times and pressures in air brake systems for road vehicles in conformity with ISO 3583.



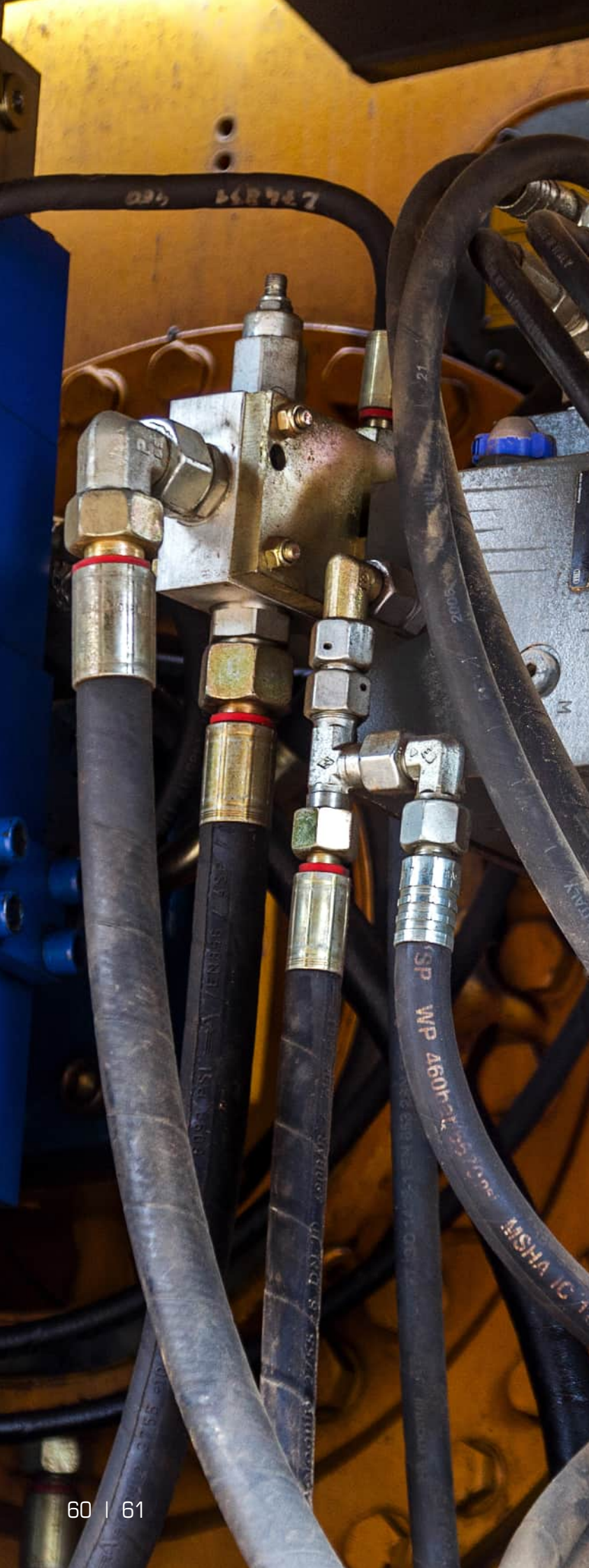

Technical notes

- | Seal types and recommended threaded ports for MINIMESS® test points and gas charging valves
- | Pressure loss curves for MINIMESS® hose and hose lines
- | Installation notes for MINIMESS® hose lines
- | General technical notes for MINIMESS® products
- | Resistance specifications

Seal types and recommended threaded ports for **MINIMESS®** test points and gas charging valves

Hydrotechnik type B
ISO 9974-3, ISO 1179-4

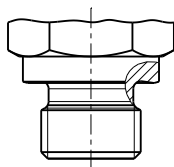

Seal achieved with sealing edge

Hydrotechnik type F
ISO 9974-2, ISO 1179-2

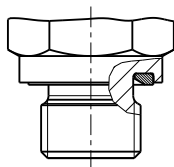

Seal achieved with ED seal

ISO 9974-1, ISO 1179-1

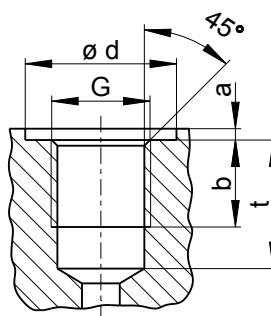

G	d	a	b	t
M10 x 1	15.0	1.0	8.0	13.0
M12 x 1.5	18.0	1.5	12.0	18.5
M14 x 1.5	20.0	1.5	12.0	18.5
M16 x 1.5	22.0	1.5	12.0	18.5
ISO 228-G 1/8	15.0	1.0	8.0	13.0
ISO 228-G 1/4	20.0	1.5	12.0	18.5
ISO 228-G 3/8	23.0	2.0	12.0	18.5
ISO 228-G 1/2	27.0	2.5	14.0	22.0

Hydrotechnik type C
ISO 3852-2 type C

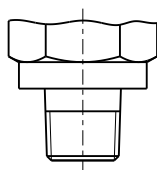

Seal achieved with suitable sealant

ISO 3852-2 type Z

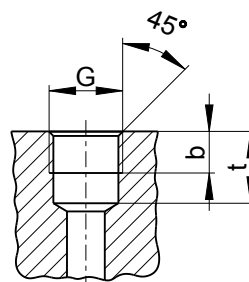

G	b	t
ISO7-1 – R1/8	5.5	9.5
ISO7-1 – R1/4	8.5	13.5

Hydrotechnik type E

ISO 6149-2, ISO 11926-2, SAE J514

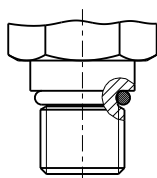

Seal achieved with O-ring

ISO 6149-1, ISO 11926-1, SAE 14026-1

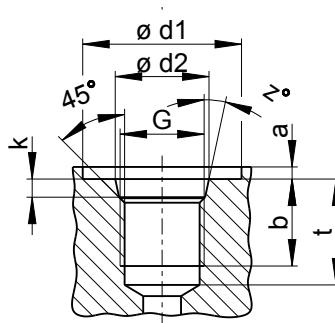

G	d_1	d_2	b	k	t	a	z
M10 x 1	19.0	11.1	10.0	1.6	11.5	1.0	12.0
M12 x 1.5	19.0	13.8	11.5	2.4	14.0	1.5	15.0
M14 x 1.5	21.0	15.8	11.5	2.4	14.0	1.5	15.0
M16 x 1.5	24.0	17.8	13.0	2.4	15.5	1.5	15.0
7/16-20 UNF	21.0	12.4	11.5	2.4	14.0	1.6	12.0
1/2-20 UNF	23.0	14.0	11.5	2.4	14.0	1.6	12.0
9/16-18 UNF	25.0	15.6	12.7	2.5	15.5	1.6	12.0
3/4-16 UNF	30.0	20.6	14.3	2.5	17.5	2.4	15.0

Hydrotechnik type G

HTS 0221

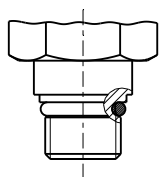

Seal achieved with O-ring

Hydrotechnik in-house standard - HTS 0221

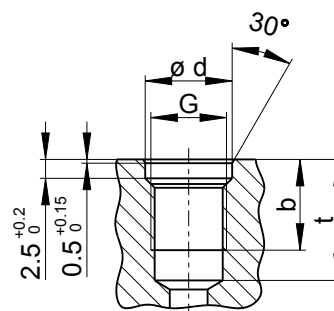

G	d	b	t
M8 x 1	9.5	9.0	13.0
M10 x 1	11.5	9.0	13.0

Seal types and recommended threaded ports for MINIMESS® test points and gas charging valves

Hydrotechnik type H
ANSI/ASME B1.20.2 type H

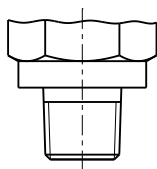

Self-sealing thread

ANSI / ASME B1.20.2 type H

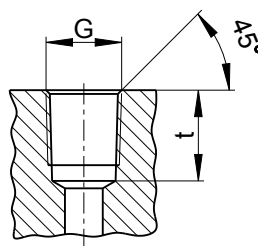

G	t
1/8 NPTF	12.0
1/4 NPTF	17.5

Recommended threaded ports for MINIMESS® p/T test points

Hydrotechnik type F

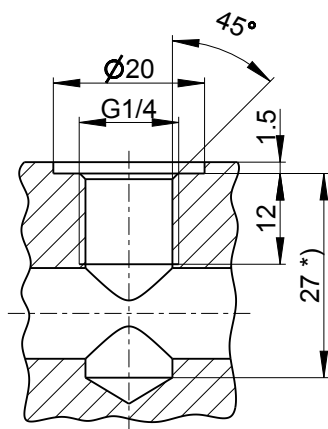

*) Recommended minimum drilled depth

Hydrotechnik type G

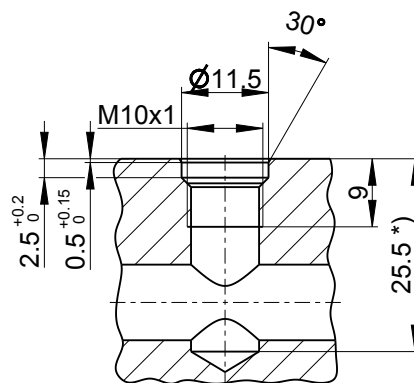

*) Recommended minimum drilled depth

Pressure loss curves for MINIMESS® hoses and hose lines

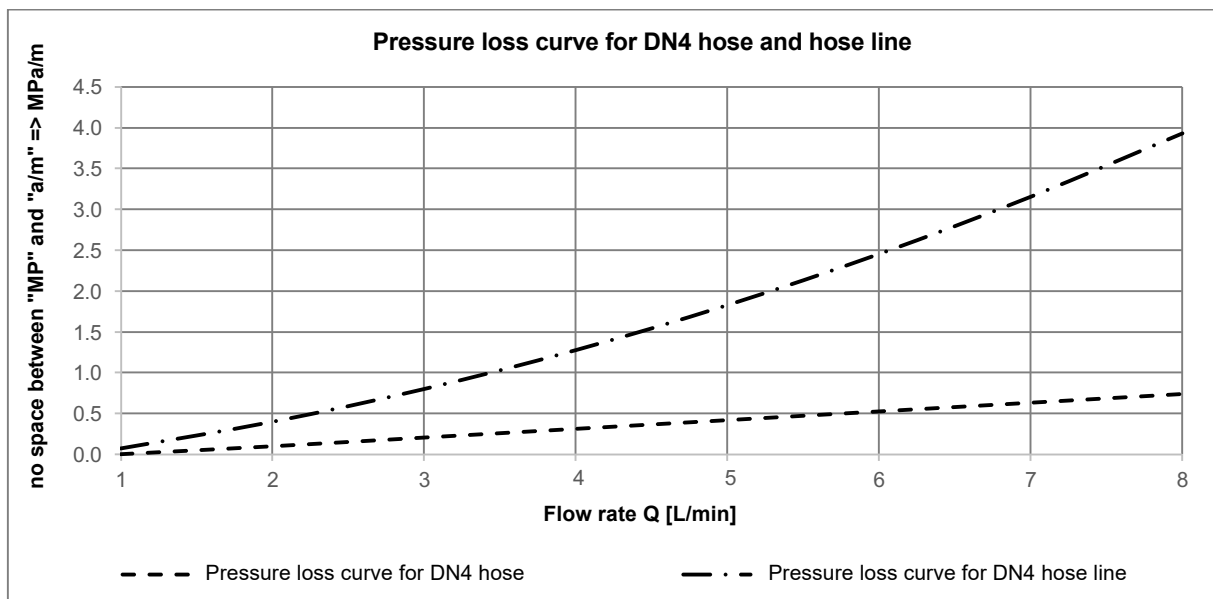
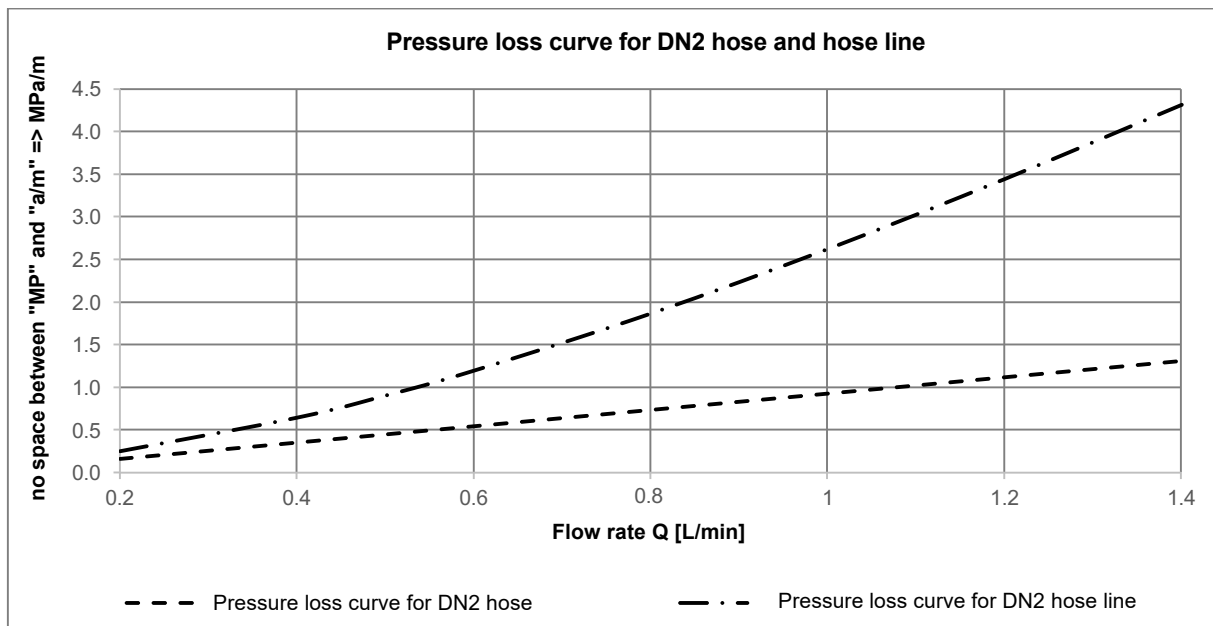

In both diagrams, curve 1 shows the pressure loss of the hose without fittings. Meanwhile, curve 2 shows the pressure loss of the hose line with MINIMESS® fittings on both ends. The oil viscosity is $30 \text{ mm}^2\text{-s}^{-1}$ in both.

Installation notes for MINIMESS® hose lines

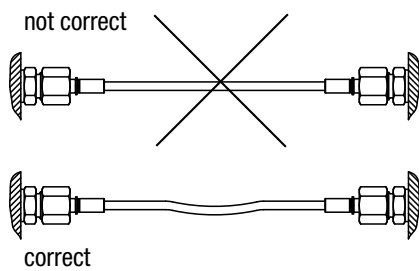

The length of a hose line can change when the latter is subjected to loads, with a reduction in length entailing a greater tensile load on the hose and the connections. Accordingly, it is important to ensure that the hose line sags a little when depressurized. Please do not tighten the swivel nuts beyond the point where the connection becomes tight, as overtightening them will not improve leak-tightness, but will damage the connection instead.

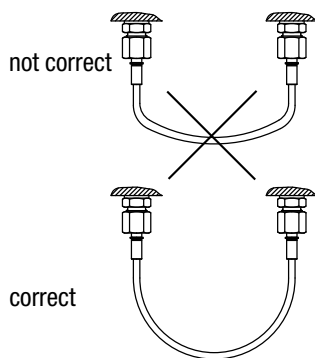

If using curved routing, make sure to observe the permissible bend radius and avoid sharp bends. When calculating the length of a hose line that is routed with a curve, keep in mind that the fittings are not flexible. Accordingly, correctly sizing the free hose length between the fittings is essential.

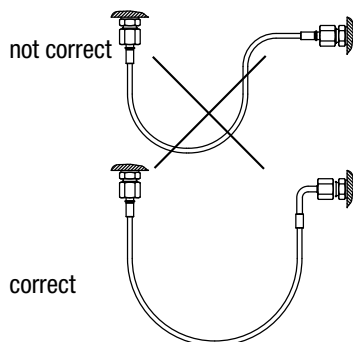

There are 90° fittings available for when installation situations warrant their use. These fittings have such a small radius that they make it possible to ensure that the corresponding hose will be routed properly even when there is little space available.

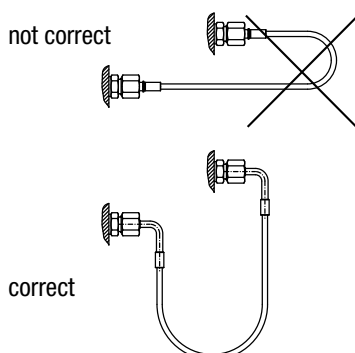

90° fittings should be used when the connections' position does not allow for a "hanging arch" and there is always a risk of kinks close to the connections in the case of a "horizontal arch."

Please make sure to use appropriately sized retainers (e.g., clamps). The hose must not rub against the retainer or be squeezed by it. Moreover, the retainer must preferably go around the hose.

General technical notes for MINIMESS® products

Intended use

MINIMESS® products are intended for use with group 2 fluids as defined in Pressure Equipment Directive 2014/68/EU (non-hazardous fluids).

Chemical compatibility

MINIMESS® test points:

- Are suitable, without restrictions, for HL, HLP, HVLP hydraulic fluids in conformity with DIN 51524.
- Are only resistant to fire-resistant and environmentally acceptable hydraulic fluids to a limited extent:
HEES, HEPR, HEPG; HFDM, HFDR, HFC in conformity with ISO 12922 and ISO15380.

Using fire-resistant or environmentally acceptable hydraulic fluids may affect the test points' technical characteristics (temperature range, pressure range, service life, etc.)

MINIMESS® gas charging valves:

- Are suitable, without restrictions, for all inert gases.
- Are also suitable for HL, HLP, HVLP hydraulic fluids in conformity with DIN 51524.

MINIMESS® hose lines:

- Are suitable, without restrictions, for HL, HLP, HVLP hydraulic fluids in conformity with DIN 51524.

For information regarding compatibility with other fluids, please refer to the resistance specifications on page 69. The use of other fluids must be checked on a case-by-case basis.

Certification criteria

MINIMESS® products are tested and certified in conformity with the relevant standards. Moreover, when there are no standards for specific characteristics, we define our own test criteria for those characteristics based on standards for related products, ensuring that we can stand 100 percent behind our products.

Testing is carried out on build samples for the corresponding item or on parts that are identical in terms of the characteristics being tested.

Resistance to corrosion

MINIMESS® products made of free cutting steel are protected against corrosion with a zinc-nickel coating. A corrosion resistance > 1,000 h has been verified with a salt spray test in conformity with DIN EN ISO 9227.

Pressure Equipment Directive 2014/68/EU

MINIMESS® test points, gas charging valves, and hose lines are designed and manufactured in conformity with the sound engineering practice of Germany as required by Article 4 of the Pressure Equipment Directive 2014/68/EU. This guarantees the safety of our products. These products should not bear the CE marking.

Packaging

Packing unit in cardboard box or in polyethylene bag and outer packaging. Alternatives available upon request.

Storage recommendations

MINIMESS® products with elastomeric seals:

Shelf lives vary by elastomer type in conformity with DIN 7716.

The storage period until installation and commissioning should not exceed 2 years.

MINIMESS® hose lines:

Storage and transportation instructions in conformity with DIN EN ISO 8331

- Store in a cool and dry place. Avoid direct exposure to sunlight and UV rays.
- Avoid sources of radiant heat.
- Avoid ozone-generating lamps and electrical equipment that produces sparks in the immediate vicinity.
- The ideal storage conditions are temperatures between +15 °C and +25 °C, a relative humidity of 65%, and UV-blocking film in order to shield from UV radiation.

A storage time of 2 years should not be exceeded for hoses.

REACH Regulation (EU) No.1907/2006, Art. 33

As a manufacturer of products, HYDROTECHNIK GmbH is a downstream user of low quantities and accordingly is not subject to mandatory registration. In accordance with Article 33 of the REACH Regulation, we are hereby informing you that the free machining steel products we supply may contain a lead concentration of up to 0.35% weight by weight and that the brass products we supply may contain a lead concentration of up to 3.5% weight by weight.

Other than this, our products do not contain any other substances found in the 2019 Candidate List of Substances of Very High Concern (SVHC).

Safety notes

Products must be assembled and installed exclusively by qualified personnel. It is recommended to always keep the protective cap on MINIMESS® test points and gas charging valves in place when they are not being used directly as system access points.

General notes

The products must be used exclusively as intended. The purchaser is responsible for making sure that the products are suitable for the intended application and for use under the corresponding operating conditions, and Hydrotechnik GmbH hereby disclaims all liability within this context.

We reserve the right to make changes to products and documentation, as a result of technological progress and continuous improvement, without notice. The specifications applicable after these changes may be different from the specifications in this catalog.



Resistance specifications

- | Seal materials: NBR (Perbunan), FKM (Viton)
- | 1.0718 free cutting steel (11SMnPb30+C), zinc-nickel-electroplated surface
- | 1.4104 stainless steel (X12CrMoS17)
- | 1.4571 stainless steel (X6CrNiMoTi17-12-2)
- | Hoses: Polyamide

Fluid	Seal materials		Fitting material			Hoses			
	NBR	FKM	1.0718	1.4104	1.4571	20 °C	40 °C	60 °C	90 °C
Acetone	3	3	1	2	1	1/5	1/6	2	3
Ethanol, pure	1	1-2	1	1	1	1/6	2	3	
Ammonia, concentrated		3 *)	1	1	1	1	1	1	1
Ammonia, liquid	2	3 *)	1	1	1	1	1		
Formic acid	3	3 *)	3	2	1	3	3	3	
Gasoline, pure	1	1	1	1	1	1	1	1/6	
Benzene	3	1-2	1	1	1	1	1/6	2	2
Brake fluid	3	3 *)	1	1	1	1	1	1	2
Butane	1	1	2	1	1	1	1	1	
Cyclohexane	1	1	1	1	1	1	1	2	
Diesel fuel	1	1	1	1	1	1	1	1	1
Freon, R12	2	1-2	1	1	1	1	1	1	1
Glycerol, pure	2	1-2	1	1	1	1	1	1	1
Glycol	1	1-2	1	1	1	1	1	2	3
Heating oil	1	1	1	1	1	1	1	1	1
Hydraulic fluid (mineral-based)	1	1	1	1	1	1	1	1	1
Kerosene	2	1	1	1	1	1	1	1/6	
Carbonic acid	1	1	3	1	1	1/4	1/4	1/4	
Methane	1	1	2	1	1	1/4	1/4	1/4	
Methyl alcohol, pure	1	3 *)	1	1	1	1/6	2	3	
Mineral oils	1	1	1	1	1	1	1	1	1
Petroleum	1	1	1	1	1	1	1	1/6	
Polyalkylene glycols (HEPG)		2 (<100 °C)	2	1	1	1	1	2/4	3/4
Propane	1	1	2	1	1	1/4	1/4	1/4	
Oxygen	2	1	3	1	1	1/4	1/4	2/4	3/4
Lubricating oils and greases	1	1	1	1	1	1	1	1	1
Soap suds	1	1	3	1	1	1	1	1	1
Nitrogen	1	1	1	1	1	1/4	1/4	1/4	
Synthetic esters (HEES)		2 (<100 °C)	1	1	1	1	1	2/4	3/4
Turpentine	2	1	2	1	1	1	1	1/6	
Carbon tetrachloride	3	1	2	1	1	1	3		
Toluene	3	1-2	2	1	1	1	1/6	2	2
Trichloroethylene	3	1-2	1	1	1	2	3		
Triglycerides (vegetable oil) HETG	1	2 (<80 °C)	1	1	1	1	1	2/4	3/4
Water	1	1	3	1	1	1	1	1	1
Seawater	1	1	3	3	2	1	1	1	1

Key:

1 = Good; absolute resistance without any changes

2 = Limited; resistance depends on length of use and operating conditions

3 = Not recommended; the material will be attacked and the mechanical properties will degrade

4 = Light diffusion in the cases of gases; use only as a testing and filling hose. For continuous use, we recommend our stainless steel pipes instead

5 = Slight transparent material discoloration

6 = Light swelling but no changes to mechanical properties

*) Suitable seal materials available upon request