

11.20 Maßblatt Verschleißteil-Einsätze

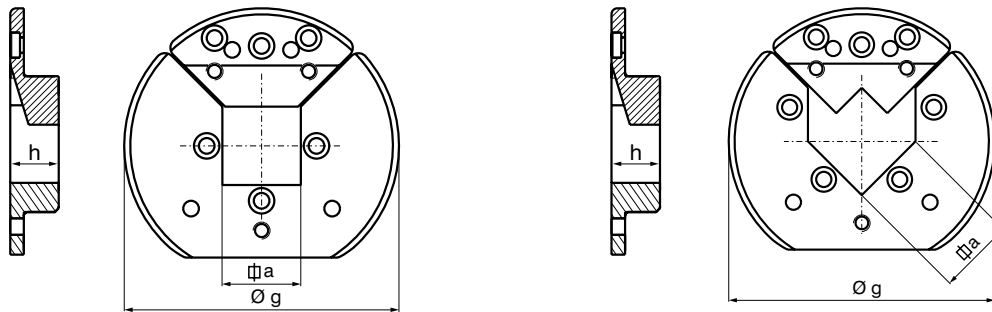

VT 1 / VT 2

| Maß a (mm) H8 | | | | | | | | | | g | h | |
|--------------------|------|--------|--------|--------|----|--------|------|--------|-------|-----|-----|----|
| 22-30 | 25 | 30 | | | | | | | | 104 | 22 | |
| 30-40 | | 30 | 32 | 35 | 40 | | | | | 140 | 25 | |
| 40-50 | | | | | 40 | 45 | 50 | | | 144 | 27 | |
| 50-80 | | | | | | | 50 | 60 | 80 | 195 | 35 | |
| 80-120 | | | | | | | | 80 | 100 | 120 | 230 | 55 |
| Maß a (inch/mm) H8 | | | | | | | | | | g | h | |
| 22-30 | 1" | 1 1/8" | 1 1/4" | | | | | | | 104 | 22 | |
| | 25,4 | 28,57 | 31,75 | | | | | | | | | |
| 30-40 | | | 1 1/4" | 1 1/2" | | | | | | 140 | 25 | |
| | | | 31,75 | 38,1 | | | | | | | | |
| 40-50 | | | 1 1/4" | 1 1/2" | | 1 3/4" | 2" | | | 144 | 27 | |
| | | | 31,75 | 38,1 | | 44,45 | 50,8 | | | | | |
| 50-80 | | | | | | | 2" | 2 1/2" | 3" | 195 | 35 | |
| | | | | | | | 50,8 | 63,5 | 76,2 | | | |
| 80-120 | | | | | | | | | 4" | 230 | 55 | |
| | | | | | | | | | 101,6 | | | |

VT2: 50-80 a = max. 63,5

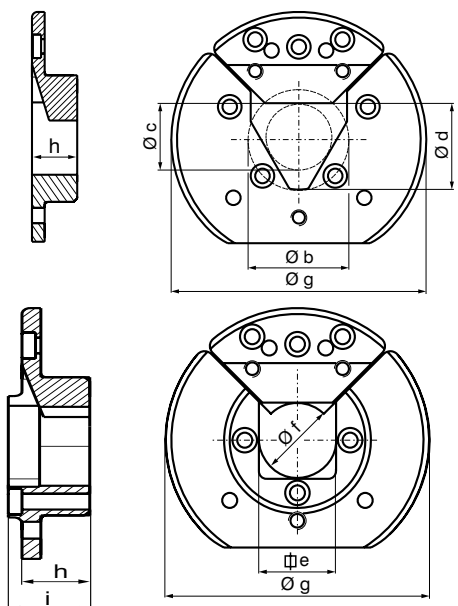

VT 6

| | Maß (mm) | | | | |
|--------|----------|----|------|-----|----|
| | b | c | d | g | h |
| 22-30 | 45 | 30 | 37,5 | 104 | 22 |
| 30-40 | 55 | 36 | 45,5 | 140 | 25 |
| 40-50 | 70 | 46 | 58 | 144 | 24 |
| 50-80 | 105 | 67 | 86 | 195 | 35 |
| 80-120 | 150 | 96 | 123 | 230 | 55 |

VT 7

| | Maß (mm) | | | | |
|--------|----------|------|-------|----|----|
| | e | f F7 | g | h | i |
| 22-30 | 31 | 30 | 104 | 22 | 25 |
| 30-40 | 41 | 40 | 140 | 25 | 30 |
| 40-50 | 51 | 50 | 144 | 27 | 31 |
| 50-80 | 51 | 50 | 195,5 | 35 | 41 |
| 80-120 | 81 | 80 | 195,5 | 35 | 41 |

Weitere Ausführungen auf Kundenwunsch

Generell müssen Klapplager immer von Hand geschlossen werden.