

# Spannelemente **RINGFEDER® RfN 8006**

## Montage, Demontage, erneute Montage

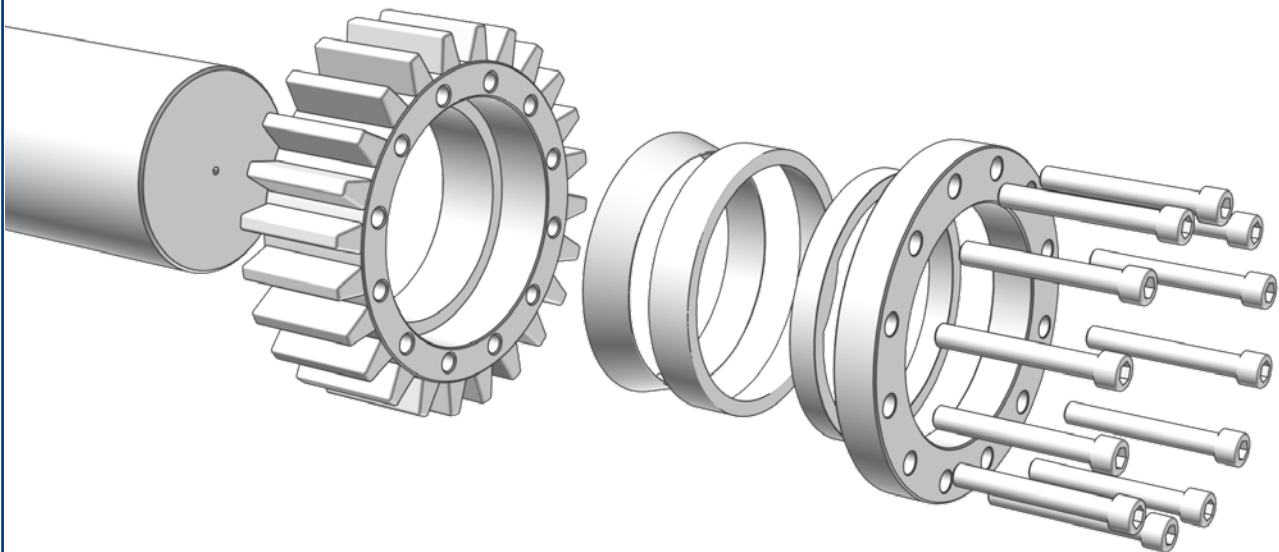

**RfN 8006  
ungeschlitzt**



**RfN 8006  
geschlitzt**

## Sicherheitshinweise

Rotierende Maschinenteile können Bediener und Servicepersonal verletzen! Deshalb:

- Schalten Sie vor Montagearbeiten den Antrieb ab.
- Sichern Sie die Maschine gegen unbeabsichtigtes Einschalten.
- Montieren Sie vor Einschalten der Maschine alle Abdeckungen und Schutzeinrichtungen.
- Die Montage von RINGFEDER® Produkten darf nur durch fachkundiges Personal und für geeignete Anwendungsfälle erfolgen.

## Achtung

- Diese Anleitung bitte gründlich durchlesen.
- Bei Zuwiderhandlung gegen die Hinweise in dieser Anleitung besteht kein Haftungsanspruch.
- RINGFEDER POWER TRANSMISSION behält sich technische Änderungen zur Produktverbesserung vor.
- RINGFEDER® Spannelemente entsprechen dem anerkannten Stand der Technik.

**Bei Problemen oder Rückfragen stehen Ihnen unsere Mitarbeiterinnen und Mitarbeiter aus Technik und Service gerne zur Verfügung. Die entsprechenden Kontaktinformationen finden Sie auf der Rückseite dieser Anleitung.**

## Verwendete Schmiermittel

### Bezeichnung

Maschinenöl Shell Omala 220 oder vergleichbares

## Legende



Montage



Demontage



Erneute Montage



Reinigen



Nabe und Welle gegebenenfalls leicht einölen (keine MoS2-haltigen Öle verwenden).

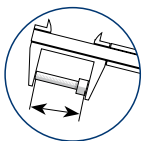

Schraube auf Verformung prüfen und gegebenenfalls austauschen.



Beschriebenen Vorgang über Kreuz in so vielen Durchgängen wie angegeben ausführen.



Beschriebenen Vorgang in so vielen Durchgängen wie angegeben ausführen.



Auf zulässige Rauhtiefe prüfen.



Achtung! Unbedingt beachten!



Gültige Daten über die erforderlichen Anzugsmomente können dem Product Paper & Tech Paper „Spannelemente“ sowie unserer Webseite entnommen werden. Bitte prüfen Sie, ob der Maschinen-/Anlagenbauer abweichende Anzugsmomente vorgegeben hat.



Bauteil ohne Freistich



Bauteil mit Freistich



Einbau zusätzlicher Spannelemente

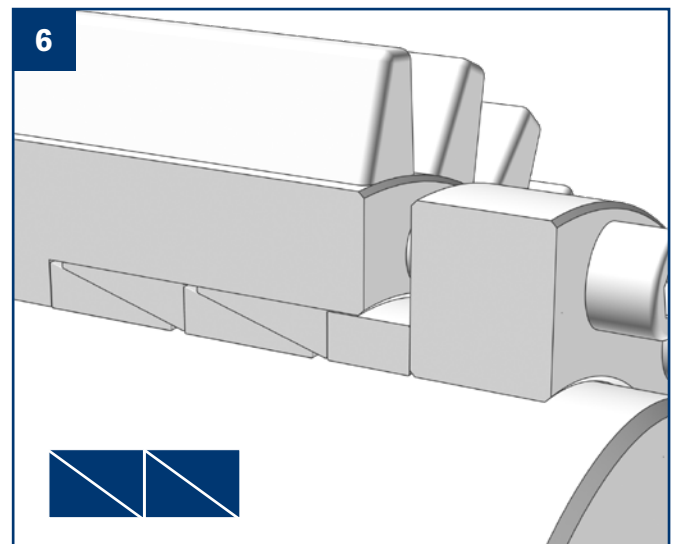
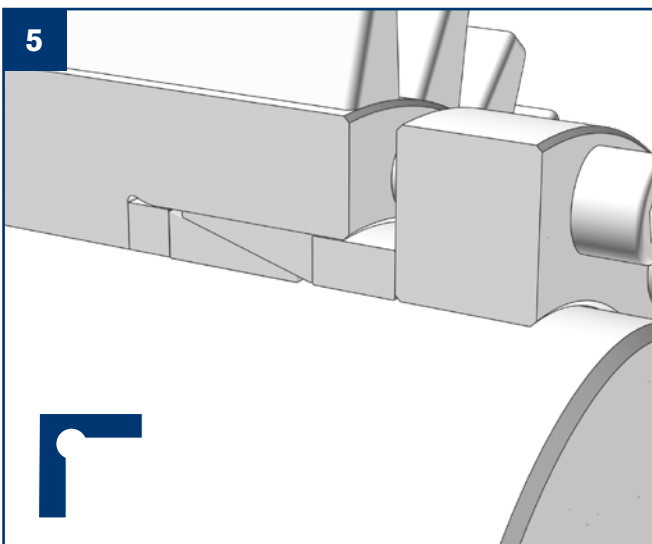
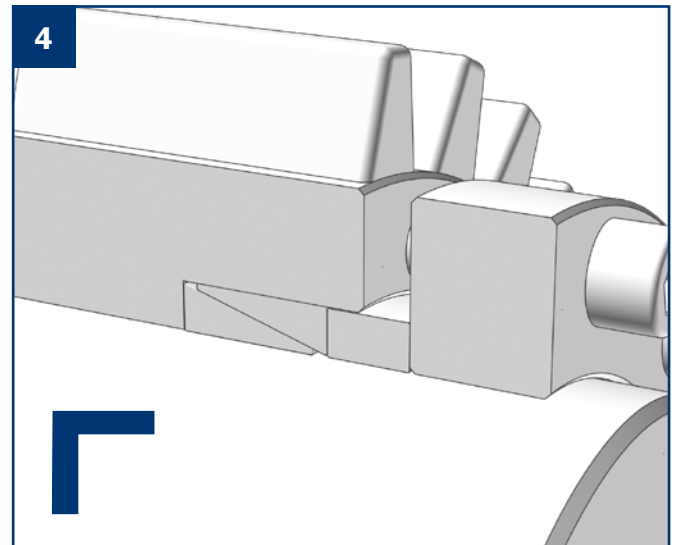
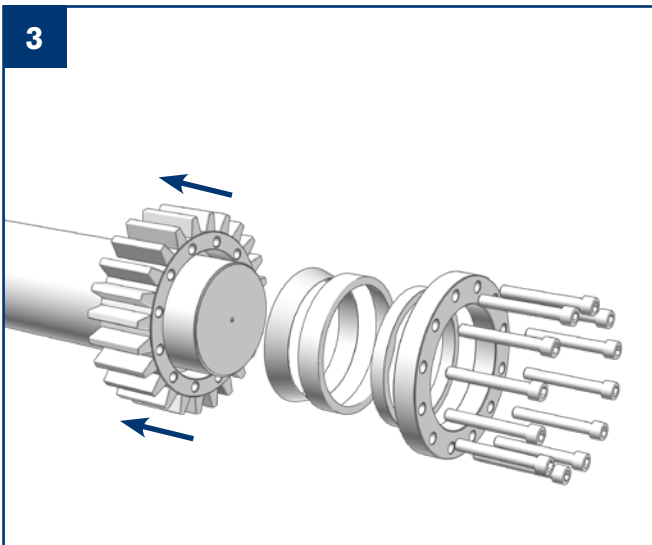
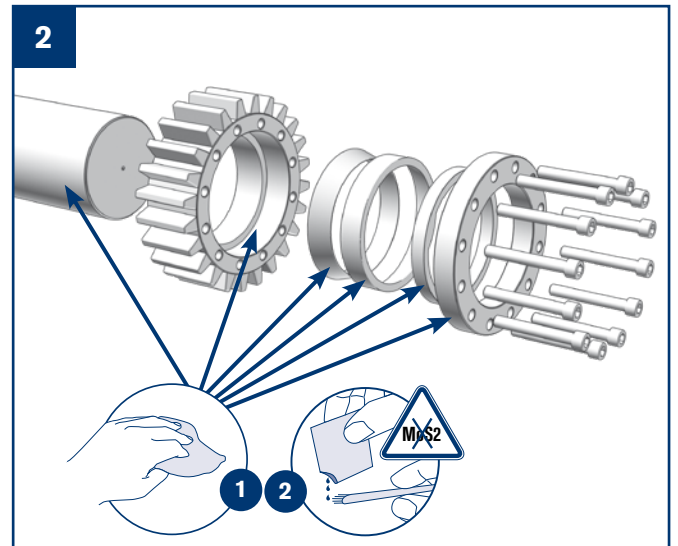
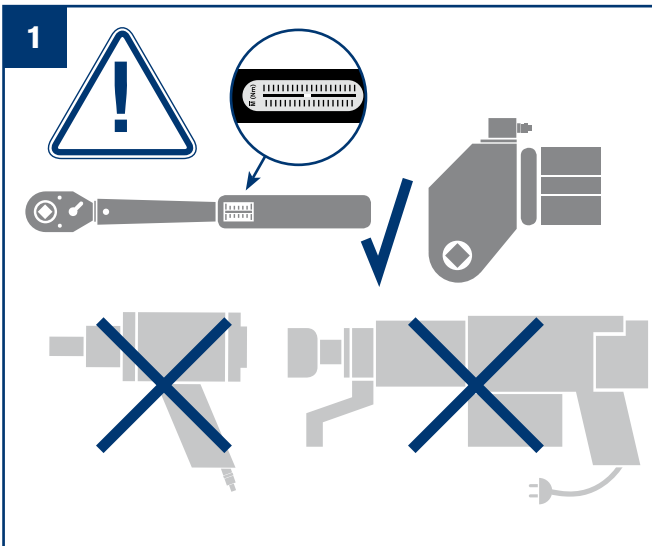

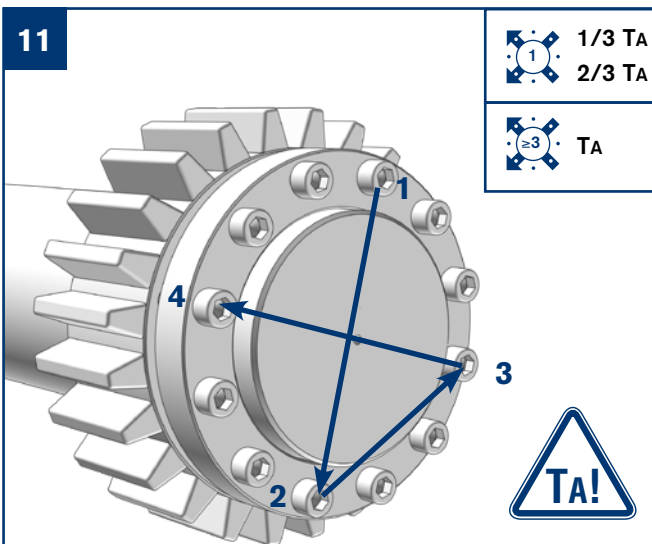
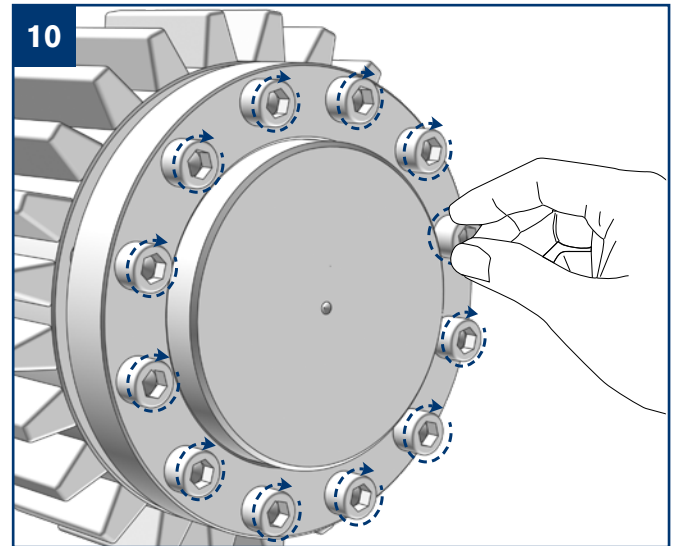
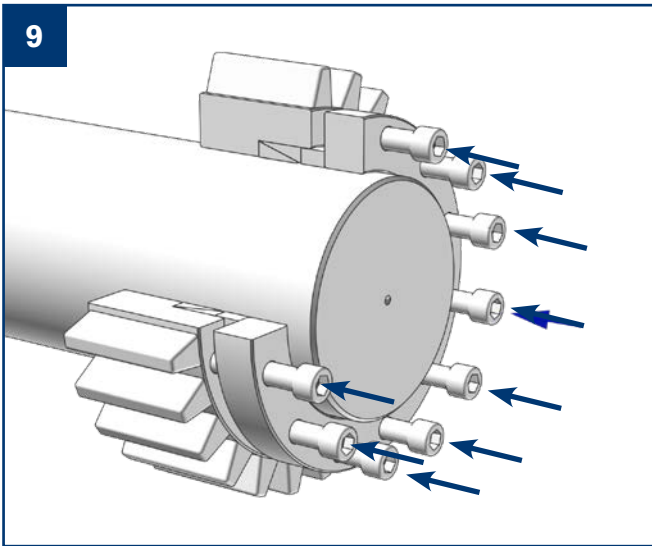
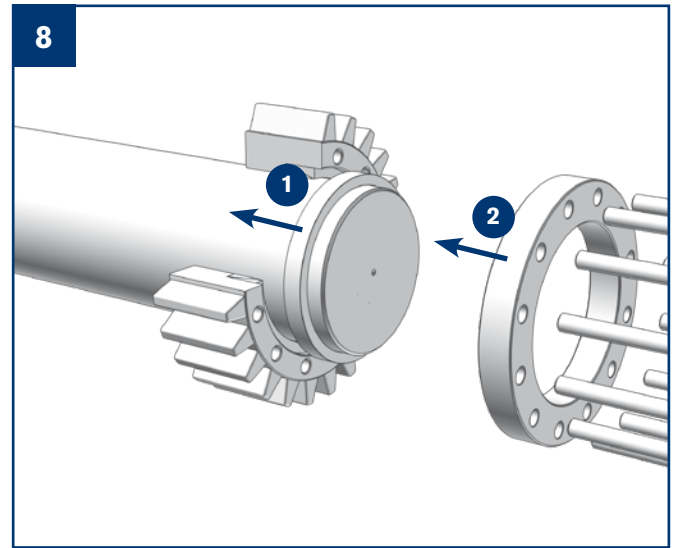
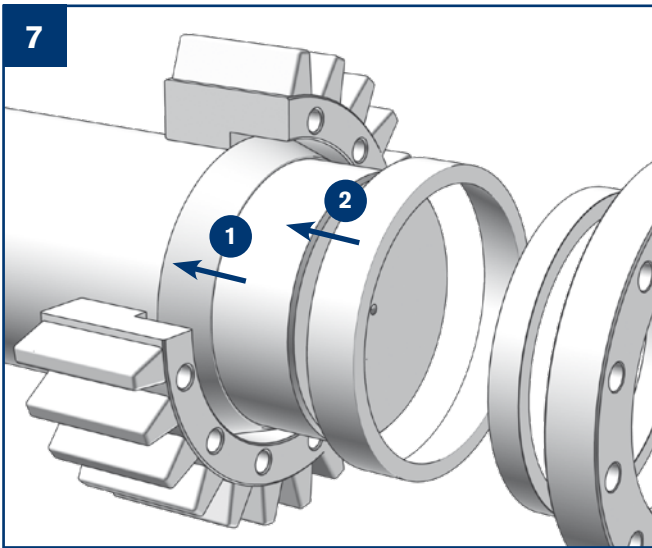

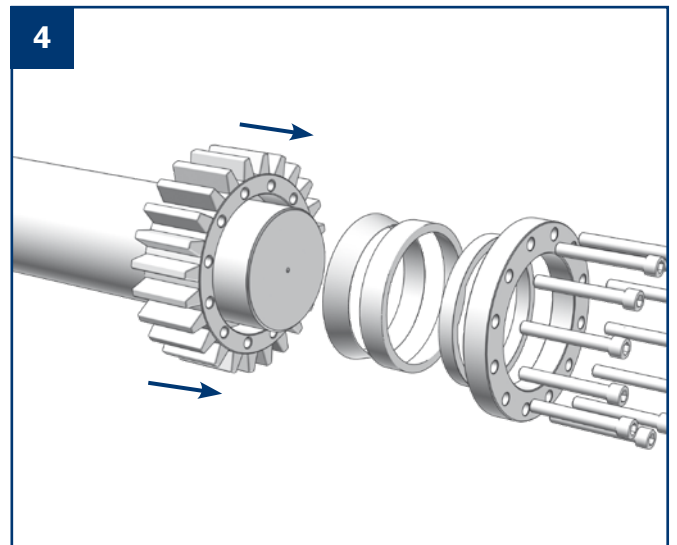
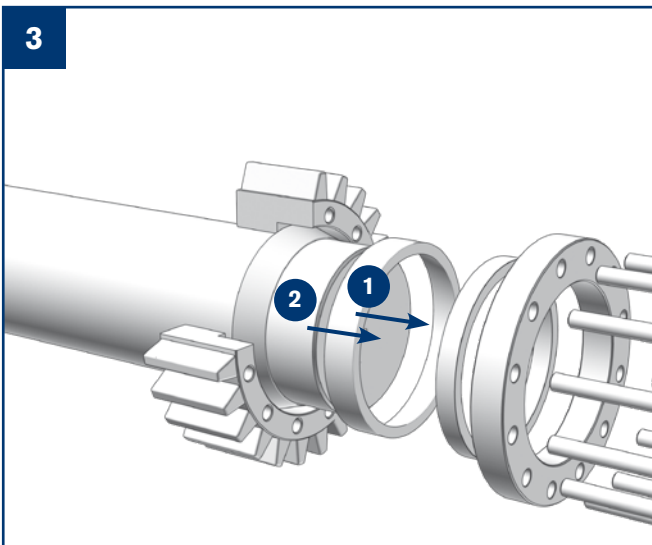
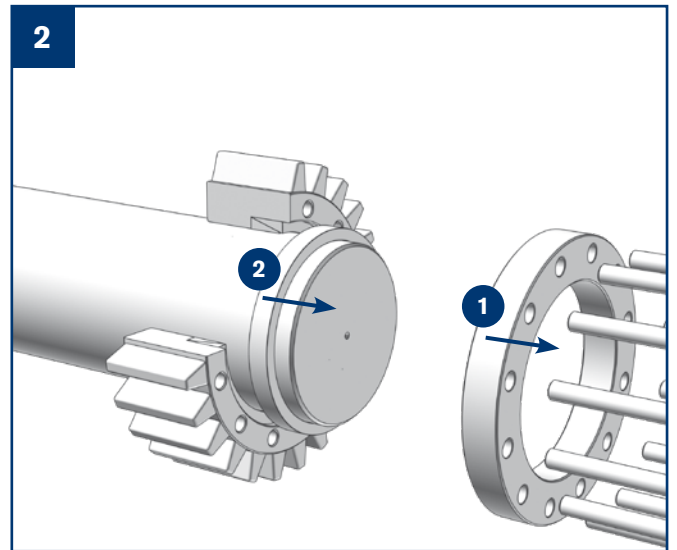
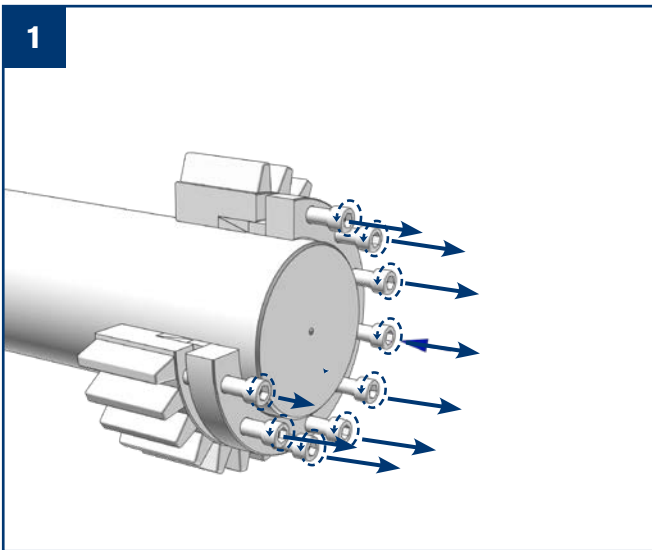

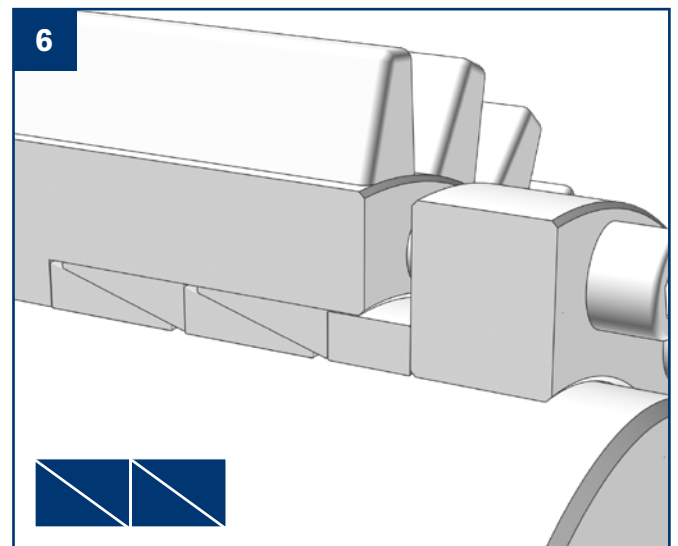
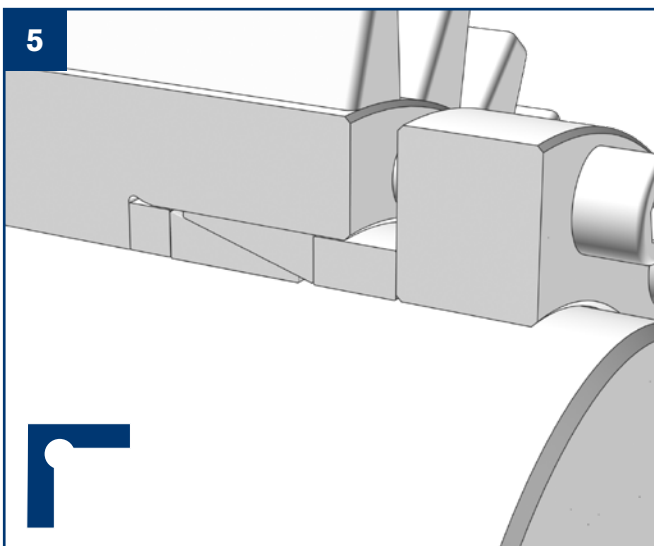
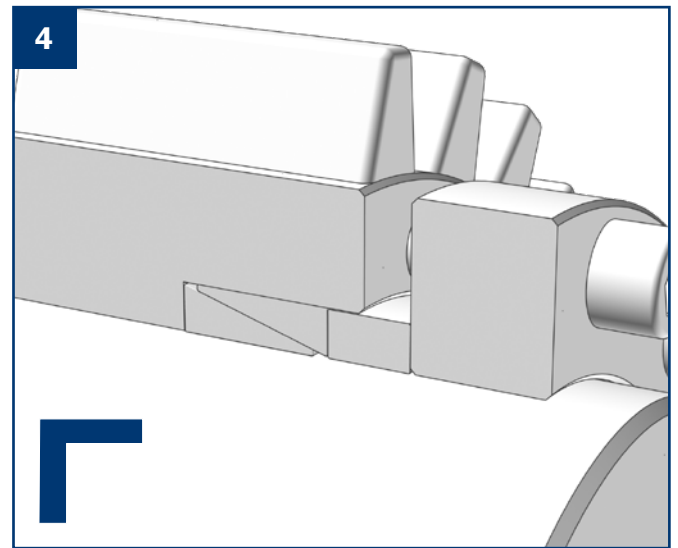
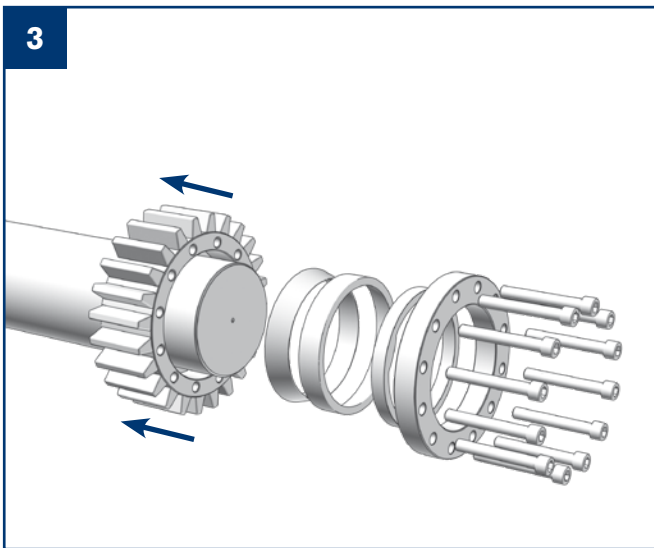
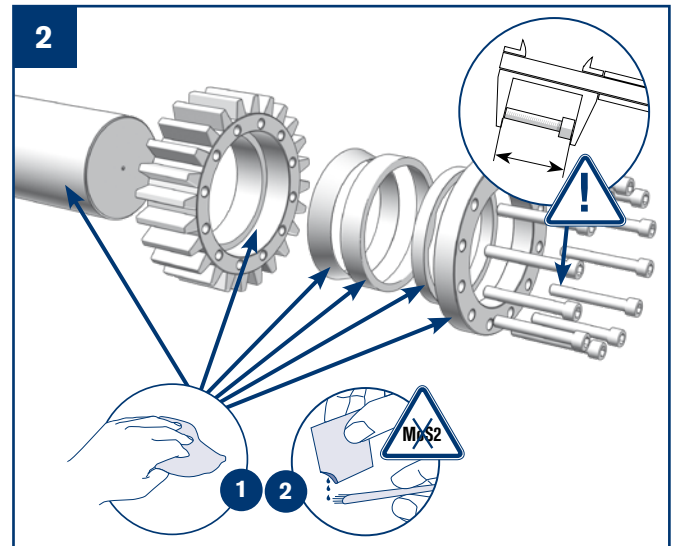
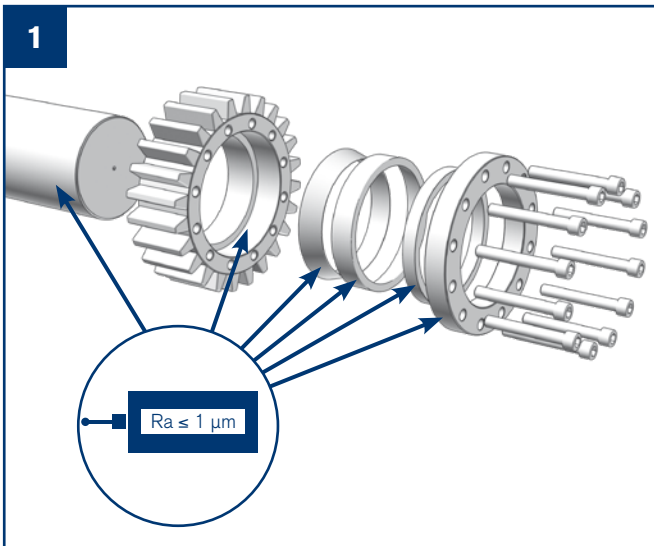

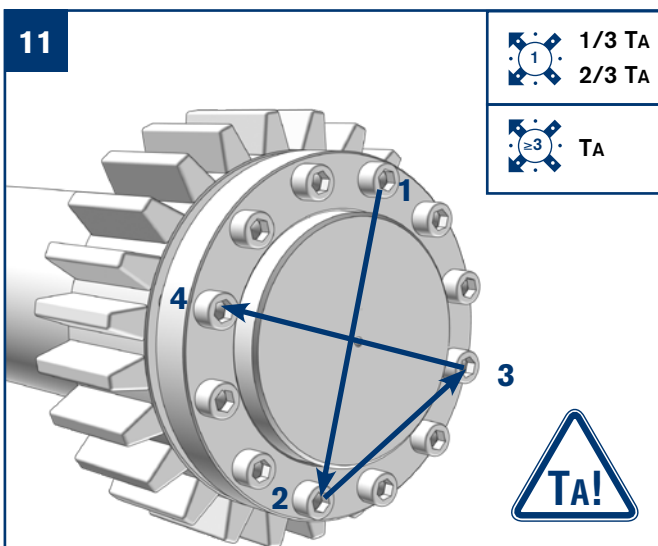
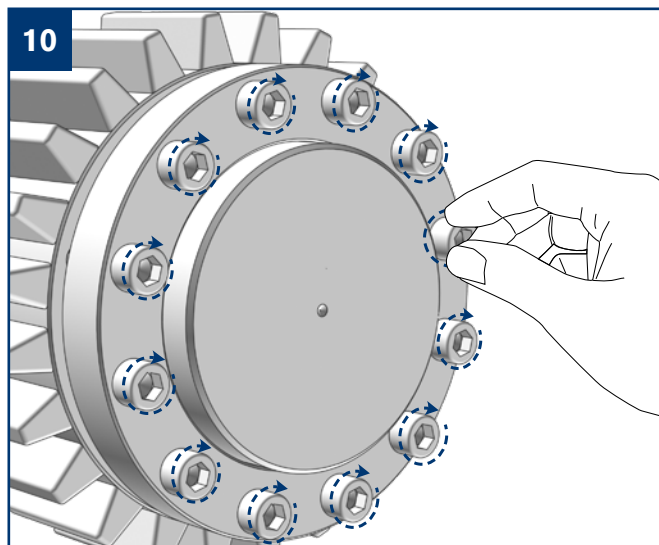
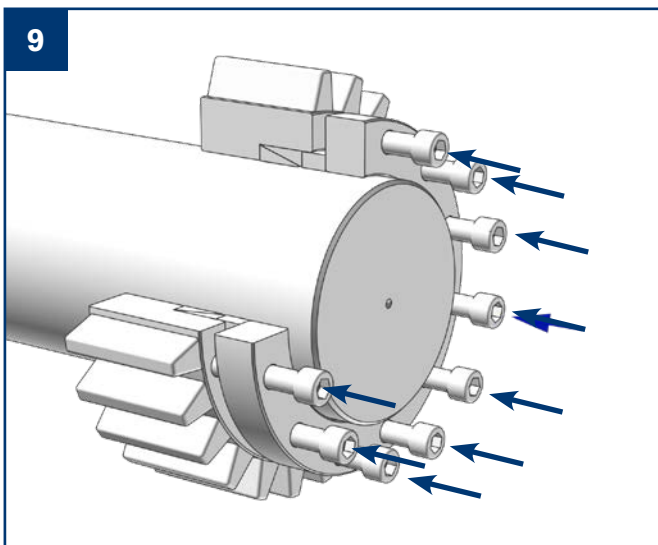
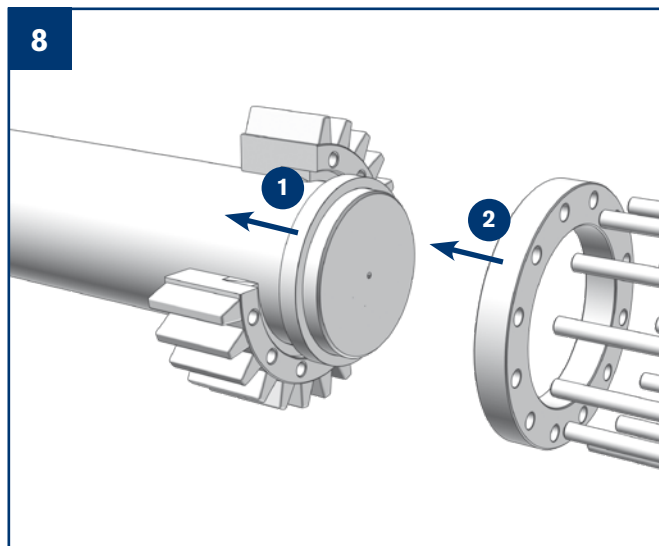
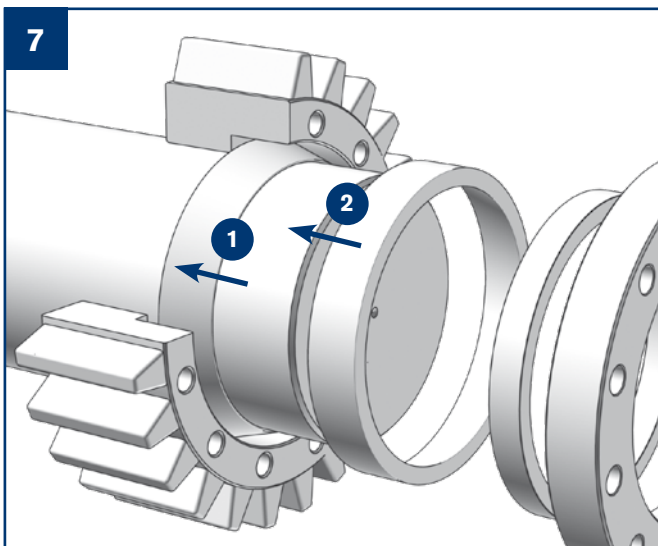

**RINGFEDER POWER TRANSMISSION GMBH**

Werner-Heisenberg-Straße 18, 64823 Groß-Umstadt, Germany · Phone: +49 6078 9385-0 · Fax: +49 6078 9385-100  
E-Mail: sales.international@ringfeder.com

**RINGFEDER POWER TRANSMISSION SP. Z O. O.**

Ul. Szyby Rycerskie 6, 41-909 Bytom, Poland · Phone: +48 32 301 53 00 · Fax: +48 32 722 44 44 · E-Mail: sales.poland@ringfeder.com

**RINGFEDER POWER TRANSMISSION USA CORP.**

291 Boston Turnpike, Bolton, CT 06043, USA · Toll Free: +1 888 746-4333 · Phone: +1 201 666-3320 · Fax: +1 860 646-2645  
E-Mail: sales.usa@ringfeder.com

**CARLYLE JOHNSON MACHINE COMPANY, LLC.**

291 Boston Turnpike, Bolton, CT 06043, USA · Phone: +1 860 643-1531 · Fax: +1 860 646-2645 · E-Mail: info@cjmco.com

**HENFEL INDÚSTRIA METALÚRGICA LTDA.**

Av. Maj. Hilário Tavares Pinheiro 3447, Pq. Ind. Carlos Tonanni, CEP 14871-300, Jaboticabal, SP, Brazil · Phone: +55 (16) 3209-3422  
E-Mail: vendas@henfel.com.br

**RINGFEDER POWER TRANSMISSION INDIA PVT. LTD.**

Plot No. B-26/2, SIPCOT Growth Centre, Vandalur Oragadam Road, Panapakkam Modu, Sriperumbudur Thaluk, Kancheepuram District, 602105, India · E-Mail: sales.india@ringfeder.com

**KUNSHAN RINGFEDER POWER TRANSMISSION CO. LTD.**

No. 406 Jiande Road, Zhangpu 215321, Kunshan, Jiangsu Province, China · Phone: +86 512 5745-3960  
Fax: +86 512 5745-3961 · E-Mail: sales.china@ringfeder.com

Partner for Performance  
[www.ringfeder.com](http://www.ringfeder.com)

