

# Anschlussteile Connecting parts



Gelenkaugen  
Hinge eyes



Winkelgelenke  
Elbow joints



Gabelköpfe  
Clevises



Gelenkköpfe  
Hinge heads



Beschläge  
Brackets



Sonderausführungen  
Special connecting parts

Die sinnvolle Vielfalt der easylift Anschlußteile kennt nur einen Maßstab – Ihre tägliche Praxis!

The reasonable variety of the easylift connecting parts knows only one measure... your daily experience.

Zur gezielten und gesteuerten Kraftentfaltung gehören auch Anschlußteile, die Bewegung und Kraftübertragung in idealer Weise – und lange Zeit – gewährleisten. Das umfangreiche easylift-Angebot an Gelenkaugen, Gabelköpfen, Winkelgelenken, Gelenkschrauben und Beschlägen, wird nahezu jedem praktischen Montageanspruch gerecht.

For a detailed and controlled force development, you will also need connecting parts which guarantee movement and force transfer in an ideal way. The comprehensive easylift range of hinge eyes, clevises, elbow joints, ball joints and metal fittings will fit nearly every mounting requirement.

Selbstverständlich wird auch das praxisbewährte easylift System immer wieder vor neue Aufgaben im Bereich der Anschlußmöglichkeiten gestellt. Sollte die von Ihnen angestrebte Applikation ideal mit easylift Gasfedern zu realisieren sein, dann werden wir auch die Anschlußproblematik lösen.

Regarding connecting parts, there will, of course, be new requirements from time to time for our easylift system. If the prospective application can be solved with easylift gas springs, we will also solve the problems regarding the connecting parts.

Bitte beachten Sie, daß sich die Einbaulänge der Gasfedern durch die Wahl anderer Anschlußteile ändert. Die Einbaulänge der easylift Gasfedern wird gemessen:

- bei Gelenkaugen, Gabel- und Gelenkköpfen von Mitte Bohrung zu Mitte Bohrung
- bei Gelenken von Mitte Kugel zu Mitte Kugel (Kugelpfanne)
- bei Gewinde jeweils ohne die Gewindelänge!

Please note that the length of gas springs will change depending on your choice of different connecting parts. The length of the easylift gas springs is calculated as follows:

- from mid boring to mid boring for hinge eyes, clevises and hinge heads
- from mid ball to mid ball for elbow joints
- without connectors the thread length is not included

Technische Daten und Maße zu den standardisierten Anschlußteilen des Bansbach easylift Systems entnehmen Sie bitte den folgenden Seiten.

Please see the following pages for technical data and dimensions of the standardized connecting parts of the easylift system.



# Anschlusssteile | Connecting parts

## Gelenkaugen Kolbenstange | Hinge eyes piston rod side

Code	SW	Ø	L <sub>1</sub>	L <sub>3</sub>	Ø <sub>2</sub>	d <sub>1</sub>	Gewinde thread	geeignet für: suitable for:			Material material
								Gasdruckfedern Gas springs	Blockierb. Gasfedern Lockable gas springs	Gaszugfedern Gas traction springs	
Q1	3,0	4,1	11,0	5,0	7,0	3,0	M3	●			Alu aluminium
H1	3,0	4,1	12,0	6,0	8,0	4,0	M4	●			Stahl steel
D1	3,0	6,2	16,0	9,0	11,0	6,0	M5	●		●	Stahl steel
F1	6,0	6,2	16,0	10,0	10,0	6,0	M5	●		●	Stahl steel
E1	3,0	8,2	16,0	9,0	11,0	6,0	M5	●		●	Stahl steel
D2	5,0	6,2	23,0	11,5	16,0	8,0 - 10,0	M8	●		●	Alu aluminium
E2	5,0	8,2	23,0	12,5	16,0	8,0 - 10,0	M8	●		●	Alu aluminium
E2/KL	5,0	8,2	23,0	11,5	19,0	8,0 - 10,0	Ø8	●		●	Alu aluminium
A1	10,0	8,2	20,0	20,0	16,0	8,0 - 10,0	M8	●		●	Alu aluminium
H2	10,0	6,2	20,0	20,0	16,0	8,0 - 10,0	M8	●		●	Alu aluminium
M2	10,0	10,2	20,0	20,0	16,0	8,0 - 10,0	M8	●		●	Alu aluminium
J2	8,0	8,2	20,0	10,0	16,0	8,0 - 10,0	M8	●		●	Alu aluminium
K2	12,0	8,2	20,0	10,0	16,0	8,0 - 10,0	M5, M8	●		●	Alu aluminium
W2	8,0	8,2	27,0	12,0	16,0	8,0 - 10,0	M8	●		●	Alu aluminium
G2	8,0	6,2	20,0	10,0	16,0	8,0 - 10,0	M8	●		●	Alu aluminium
A2	18,0	8,2	25,0	25,0	18,0	8,0 - 14,0	M8, M10	●		●	Zink-Druckguss die-cast zinc
B2	18,0	10,2	25,0	25,0	18,0	8,0 - 14,0	M8, M10	●		●	Zink-Druckguss die-cast zinc
X3	14,0	8,2	20,0	20,0	19,0	8,0 - 14,0	M8, M10	●		●	Alu aluminium
B1	12,0	8,2	25,0	12,0	19,0	10,0 - 14,0	M8, M10	●		●	Alu aluminium
L2	12,0	10,2	25,0	12,0	19,0	10,0 - 14,0	M10	●		●	Alu aluminium
N2	10,0	8,2	30,0	16,0	19,0	12,0 - 16,0	M10	●		●	Alu aluminium
Z2	12,0	12,2	25,0	11,0	19,0	12,0 - 14,0	M8, M10	●		●	Alu aluminium
Z1	10,0	8,5	30,0	16,0	19,0	12,0 - 16,0	M10	●		●	Alu aluminium
M2	10,0	10,2	30,0	16,0	19,0	10,0 - 16,0	M10	●		●	Alu aluminium
Q2	10,0	10,5	30,0	16,0	19,0	12,0 - 16,0	M10	●		●	Alu aluminium
C1	14,0	14,2	40,0	20,0	20,0	16,0 - 20,0	M14	●		●	Stahl steel

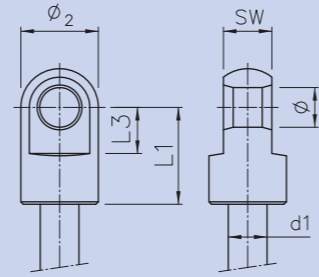

## Gewinde Kolbenstange | Threads on piston rod side

Code	M <sub>1</sub>	L <sub>1</sub>	d <sub>1</sub>	geeignet für: suitable for:		
				Gasdruckfedern Gas springs	Blockierbare Gasfedern Lockable gas springs	Gaszugfedern Gas traction springs
Q0	M3	4,0	3,0	●		
U0	M 4	4,0	4,0	●		
V0	M 5	5,0	6,0	●		
B0	M 8	9,0	8,0	●		●
H0	M 8	9,0	10,0	●		●
D0	M10	9,0	10,0 - 16,0	●		●
R0	M 6	10,0	8,0	●		
A0	M 6	8,0	8,0	●		
J0	M 8	12,0	8,0 - 10,0	●		
P0	M 8	15,0	8,0 - 10,0	●		
C0	M 8	20,0	8,0 - 10,0	●		
E0	M10	15,0	10,0 - 16,0	●		
F0	M10	20,0	10,0	●		
G0	M12	12,0	12,0	●		
Y0	M 6	6,0	6,0	●		●
Z0	MF 14 x 1,5	15,0	16,0 - 22,0	●		●
K0	MF10 x 1	18,0	10,0 - 16,0		●	
O0	MF14 x 1,5	20,0	14,0 - 22,0		●	
W0	MF8 x 1	16,0	8,0		●	
I0	M24 x 2	35,0	30,0	●		

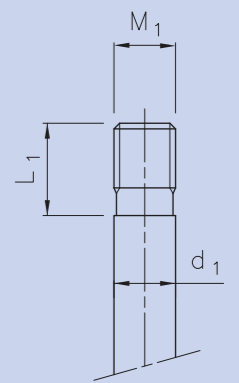
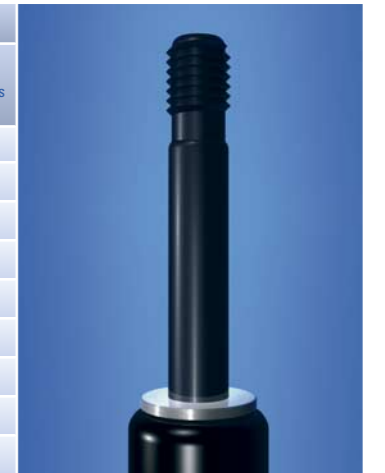

## Gelenkaugen Zylinderseite | Hinge eyes cylinder side

Code	SW	Ø	L <sub>2</sub>	L <sub>4</sub>	Ø <sub>1</sub>	d <sub>2</sub>	geeignet für: suitable for:			Material material
							Gasdruckfedern Gas springs	Blockierbare Gasfedern Lockable gas springs	Gaszugfedern* Gas traction springs*	
H1	3,0	4,1	8,0	7,0	8,0	12,0	●			Stahl steel
D2	5,0	6,2	16,0	15,0	15,0 - 17,0	19,0 - 22,0	●	●		Alu aluminium
E2	5,0	8,2	16,0	15,0	15,0 - 17,0	19,0 - 22,0	●	●		Alu aluminium
D1	3,0	6,2	12,0	10,5	11,0	15,0	●			Alu aluminium
E1	3,0	8,2	12,0	10,5	11,0	15,0	●			Stahl steel
F2	10,0	8,2	9,5	9,5	15,0	19,0	●	●		Alu aluminium
F2	10,0	8,2	12,0	11,0	17,0	22,0	●	●		Alu aluminium
A1	10,0	8,2	16,0	15,0	15,0 - 17,0	19,0 - 22,0	●	●	●	Alu aluminium
H2	10,0	6,2	16,0	15,0	15,0 - 17,0	19,0 - 22,0	●	●		Alu aluminium
M2	10,0	10,2	16,0	15,0	15,0 - 17,0	19,0 - 22,0	●	●		Alu aluminium
G2	8,0	6,2	16,0	15,0	15,0 - 17,0	19,0 - 22,0	●	●		Alu aluminium
J2	8,0	8,2	16,0	15,0	15,0 - 17,0	19,0 - 22,0	●	●	●	Alu aluminium
K2	12,0	8,2	16,0	15,0	17,0	22,0	●	●		Alu aluminium
B1	12,0	8,2	13,0	12,0	20,0	28,0	●	●	●	Alu aluminium
L2	12,0	10,2	13,0	12,0	20,0	28,0	●	●	●	Alu aluminium
N2	10,0	8,2	13,0	12,0	20,0	28,0	●	●	●	Alu aluminium
V2	6,0	8,2	13,0	12,0	20,0	28,0	●	●		Alu aluminium
Z2	12,0	12,2	13,0	12,0	20,0	28,0	●	●	●	Alu aluminium
A1	10,0	8,2	16,0	15,0	20,0	28,0	●	●		Alu aluminium
Z1	10,0	8,5	16,0	15,0	20,0	28,0	●	●		Alu aluminium
M2	10,0	10,2	16,0	15,0	20,0	28,0	●	●		Alu aluminium
Q2	10,0	10,5	16,0	15,0	20,0	28,0	●	●		Alu aluminium
M3	8,0	10,2	16,0	15,0	16,0	28,0	●	●		Alu aluminium
N3	8,0	8,2	16,0	15,0	20,0	28,0	●	●		Alu aluminium
K3	12,0	9,2	16,0	15,0	20,0	28,0	●	●		Alu aluminium

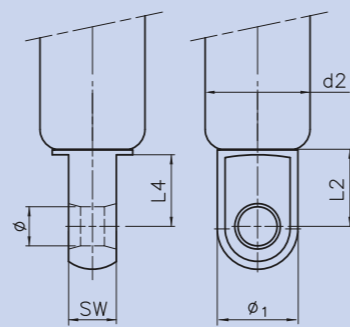

## Gewinde Zylinder | Threads on cylinder side

Code	M <sub>2</sub>	L <sub>2</sub>	d <sub>2</sub>	geeignet für: suitable for:			
				Gasdruckfedern Gas springs	Blockierbare Gasfedern Lockable gas springs	Gaszugfedern Gas traction springs	Gasfedern mit Ventil Gas springs with valve
Q0	M 3	4,0	8,0 - 10,0	●			
U0	M 4	4,0	12,0	●			
V0	M 5	5,0	15,0 - 19,0	●			● (nur only Ø d2 = 15,0)
L0	M 8	13,0	19,0 - 28,0	●	●	●	
M0	M10	13,0	22,0 - 40,0	●	●	●	●
A0	M 6	8,0/12,0	19,0 / 22,0	●		●	
N0	M 8	8,0	19,0 - 28,0	●	●	●	●
S0	M10	6,0	22,0	●			
Y0	M 6	6,0	15,0	●			
Z0	MF 14 x 1,5	15,0	40,0	●		●	●
I0	M24 x 2	35,0	70,0	●			

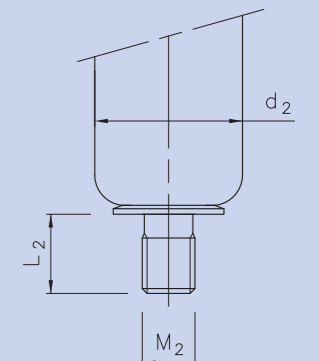
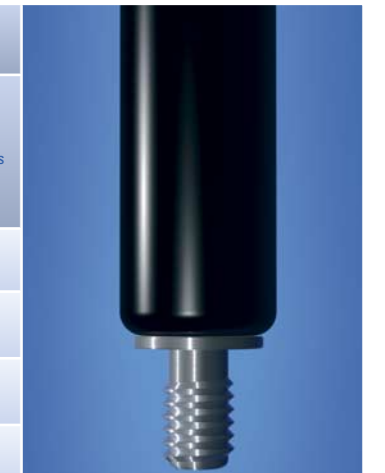

\*Gegebenenfalls geeignete Gewindepapen auswählen, sodass jedes gewünschte schraubbare Anschlusssteil verwendet werden kann. \*If possible use a suitable thread, so the preferred connection part can be used

Weitere Varianten auf Anfrage • Other variations on request

Technische Änderungen vorbehalten • We reserve the right to make technical changes at any time without prior notice



# Anschlusssteile | Connecting parts

## Kugelpfannen mit Sicherheitsbügel | Ball sockets incl. fastener

Code	Aø	L mm	b*c mm	Material
W5	10	19	M6*9, M8*9	Stahl <i>steel</i>
W6	10	18,5	M8*9	Kunststoff <i>plastic</i>
W7	10	18,5	M5*5	Kunststoff <i>plastic</i>



Code	Aø	L mm	b*c mm	Material
F5	8	18	M4*6	Stahl verzinkt <i>steel, zinc plated</i>
J3	8	22	M5*10,2	
W4	10	15	M5*5	
F3	10	19	M8*12	
P3	13	30	M6*14, M8*14	
W3	16	35	M10*15,5	



## Kugelbolzen | Bolts

Art-Nr. art. no.	Aø	d*e mm	f mm	Material
KB08M4*10.2BL	8	M4*10,2	9	Stahl verzinkt <i>steel, zinc plated</i>
KB08M5*10.2BL	8	M5*10,2	9	
KB08M5*17BL	8	M5*17	9	
KB105/16*25.4BL	10	5/16 - 18UNC-2A*25	12,7	
KB10M8*13BL	10	M8*13	12	
KB10M8*16.5BL	10	M8*16.5	12	
KB10M8*20BL	10	M8*20	12	
KB13M8*16.5BL	13	M8*16.5	13	
KB16M10*20BL	16	M10*20	16	



## Winkelgelenke | Elbow joints

Code	Aø	L mm	b*c mm	d*e mm	f mm	Material	max. Belastung/ load N*	Mutter nut
Q3	8	18	M3*6	M3*10,2	9	Stahl verzinkt <i>steel, zinc plated</i>	350	•
F4	8	18	M4*6	M4*10,2	9		500	•
B3	8	22	M5*10	M5*10,2	9		500	•
C3	10	15	M5*6	M8*13	12		740	•
J4	10	25	M6*11,5	M6*12,5	11		740	•
D3	10	19	M8*9	M8*13	12		740	•
A9	10	17	Ø 7*9	M8*13	12		740	•
Y9	10	19	M6*9 / M8*9	M8*13	12		740	•
H3	10	19	M8*9	5/16-18UNC-2A	13		740	•
A3	13	30	M8*14	M8*16,5	13		1230	•
A4	16	35	M10*15,5 / M8*15,5	M10*20	16		1900	•
B4*	19	45	M14*1,5*21,5	M14*1,5*28	20		3200	•

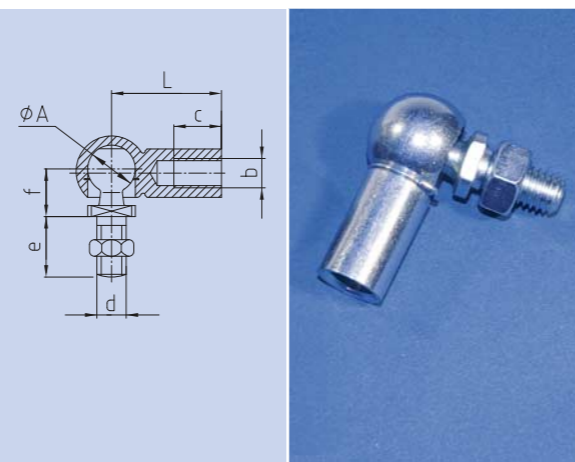

\*Ausschubkraft F1 zzgl. Progression (statisch) \*extension force F1 plus progressivity (statical)

## Gabelköpfe mit Federbolzen | Clevises with clip bolts

Code	ø d1 mm	g mm	A mm	b mm	L1 mm	L2 mm	ø d2 mm	Material
N4	4	8	8	4	21	16	M4	Stahl verzinkt <i>steel, zinc plated</i>
G5	5	10	10	5	26	20	M5	
C5	8	16	16	8	42	32	M8	
D9	10	20	20	10	52	40	M10	
L5	14	28	27	14	72	56	M14*1,5	



## Gabelköpfe ohne Federbolzen | Clevises without clip bolts

Code	ø d1 mm	g mm	A mm	b mm	L1 mm	L2 mm	ø d2 mm	Material
Q5	4	8	8	4	21	16	M3	Stahl verzinkt <i>steel, zinc plated</i>
M4	4	8	8	4	21	16	M4	
E5	5	10	10	5	26	20	M5	
A5	8	16	16	8	42	32	M8	
B9	10	20	20	10	52	40	M10	
H5	14	28	27	14	72	56	M14*1,5	
M5	25	50	50	25	132	100	M24*2	



## Federklappbolzen | Clip bolt

Code	ø d1 mm	g mm	a mm	b mm	L1 mm	L2 mm	L3 mm	Material
P4	4	8	9,5	11	19	15	4,5	Stahl verzinkt <i>steel, zinc plated</i>
F5	5	10	12	13,5	23	19	5,5	
B5	8	16	19	21,5	37	30	8	
C9	10	20	23	26	45	38	10	
J5	14	28	31	34	62	52	14	



## Gelenkköpfe | Hinge heads

Code	a	b1 mm	d1 mm	d2 mm	d3	d6 mm	h mm	L mm	L3 mm	Material
A7	8°	8	8	13	M8	23	36	16	12	Stahl verzinkt <i>steel, zinc plated</i>
A8	6°	9	10	16	M10	28	43	20	13	
C4	6,5°	6	6	10	M5	20	30	12	11	
C8	7,5°	19	14	20	M14*1,5	37	57	21	17	
M8	15°	31	25	42	M24*2	60	94	42	30	

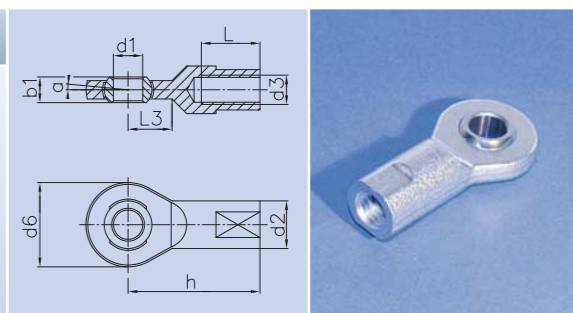

## Gelenkschrauben | Ball joints

Code	a mm	b mm	c	d mm	e	f	g mm	h	Material
G6	12	16	M5	20	M5	30°	ø 8	SW13	Stahl verzinkt <i>steel, zinc plated</i>
A6	12,5	20	M8	35	M8	30°	ø 10	SW17	
B6	12,5	20	M8	22	M8	30°	ø 10	SW17	

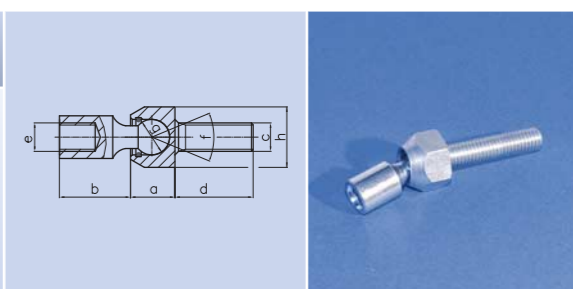

## Sonderausführungen Beispiele | Examples of special connecting parts

Kolbenstange piston rod	
H9	G9
für alle Kolbenstangendurchmesser erhältlich <i>available for all diameter</i>	
Zylinderendstück cylinder (Ø 12, 15, 19, 22, 28, 40)	
H9	U9
Bei Zylinder Ø12 und Ø15 = M5 <i>cylinder Ø12 and Ø15 = M5</i>	
N9	

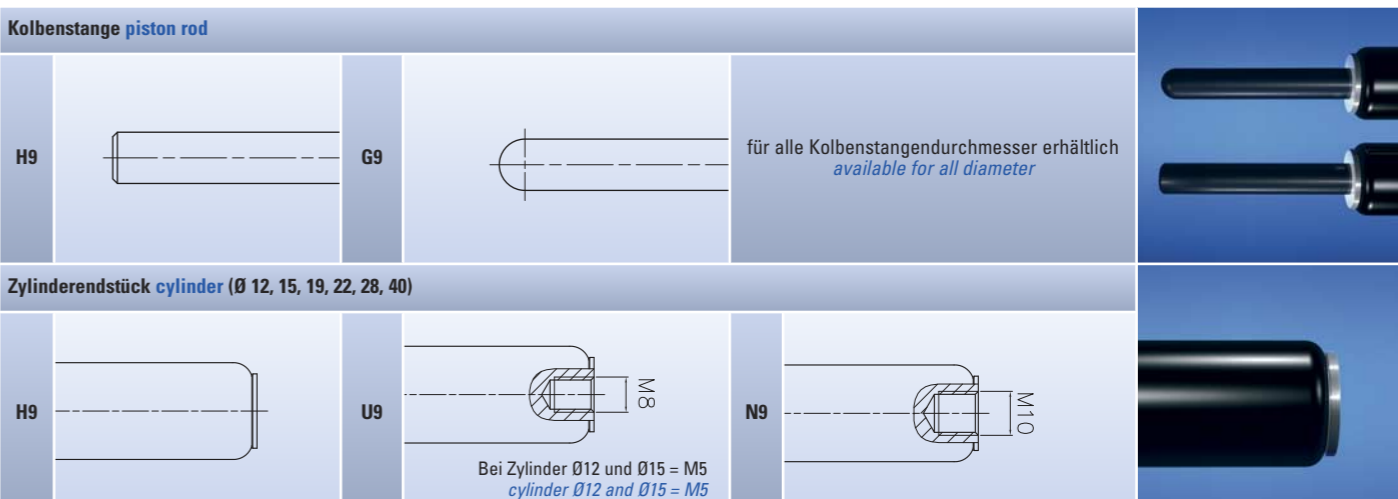

Technische Änderungen vorbehalten • We reserve the right to make technical changes at any time without prior notice

## Beschläge | Brackets

**900 BA1 SB**  
max Belastung  
max. load  
1000 N

Platte  
Bolzen  
Schnellbefestiger  
Quick fastener

Darstellung ohne die mittlere Bohrung (Bohrungs- $\phi$  ist gleich)

**900 BA2 SB**  
max Belastung  
max. load  
1000 N

Platte  
Bolzen  
Schnellbefestiger  
Quick fastener

**900 BA5 SB**  
max Belastung  
max. load  
2000 N

Material-Platte: DD11  
Material-Bolzen: 11SMn30+C  
Schnellbefestiger  
Quick fastener

**900 BA3**  
geeignet für Kugelpfannen mit  $A\phi$  10mm  
Suitable for ball sockets with  $A\phi$  10mm  
max Belastung  
max. load  
1000 N

Platte  
Bolzen (Kugel  $\phi$ 10)  
Fläche  $\phi$ 2

**900 BA4**  
geeignet für Kugelpfannen mit  $A\phi$  10mm  
Suitable for ball sockets with  $A\phi$  10mm  
max Belastung  
max. load  
800 N

Platte  
Bolzen (Kugel  $\phi$ 10)  
Fläche  $\phi$ 2

Darstellung ohne die mittlere Bohrung (Bohrungs- $\phi$  ist gleich)

**900BA6BO**  
max Belastung  
max. load  
3000 N

**900 BA12SR**  
max Belastung  
max. load  
180 N

Sicherungsring  
retaining ring

**900 BA14SR**  
max Belastung  
max. load  
180 N

Sicherungsring  
retaining ring

**900 BA20SR**  
max Belastung  
max. load  
180 N

Sicherungsring  
retaining ring

**900 BA21SR**  
max Belastung  
max. load  
180 N

Sicherungsring  
retaining ring

### Nachfüllkoffer für Gasfedern mit Ventil | Filling case for gas springs with valve

Artikel-Nr.	Art.-No.
NACHFUELLKOFFER-001 (analog)	
NACHFUELLKOFFER-002 (digital)	

- 1 Flaschendruckminderer, Anschlussgewinde W24,32 x 1/14 RH
- 1 Dreivegekegelhahn Anschlussgewinde 1/4"
- Füllglocke(n) gemäß Ihres Auftrags (eine inklusive)
- Ablassschraube(n) passend zu den Füllglocken
- 1 Hochdruckschlauchverbindung 1000 mm Länge

- 1 bottle pressure diminisher, connecting thread W24,32 x 1/14 RH
- 1 three-way diverter ball valve, connecting thread 1/4"
- Filling adapter(s) according to your order (one included)
- Depressurizing screws suitable for the containing filling adapters
- 1 high-pressure-tube connector 1000 mm length

### Verfügbare Ablassschrauben für Gasfedern mit Ventil | Available release screws for gas springs with valve

Artikel-Nr.	Art.-No.	für Gewinde for thread	Zylinder Cylinder $\phi$ mm
XXAS15MV0		M5 x 5	15
XXAS19MN0		M8 x 8	19 & 22
XXAS22MM0		M10 x 13	22
XXAS28MN0		M8 x 8	28
XXAS28MM0		M10 x 13	28
XXAS40MM0		M10 x 13	40
XXAS40MZ0		M14 x 1.5 x 15	40