

Model S

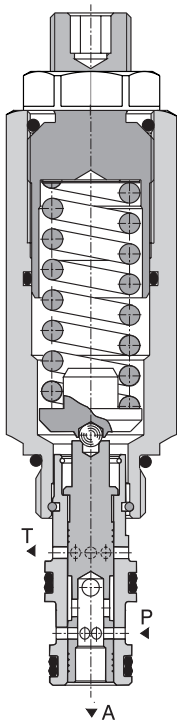

Technical Features

- › Excellent stability throughout flow range with rapid response to dynamic pressure changes
- › Low hysteresis, accurate pressure control and low pressure drop
- › Three-way valve with relief function for protection of actuator against pressure overloading
- › Wide range of input pressure up to 350 bar
- › Precise produced and hardened function parts
- › Reduced pressure adjustable by allen key or hand screw
- › In the standard version, the valve is zinc-coated for 240 h protection acc. to ISO 9227. Enhanced surface protection for mobile sector available for the steel parts (ISO 9227, 520 h salt spray)

Functional Description

The valve provides an adjustable regulated pressure level below supply pressure. This direct acting model is suitable for applications with lower flow rates and lower regulated pressures. In case of shock or surge pressures in the downstream line the valve acts as a relief valve, directing excessive pressure and flow to the tank.

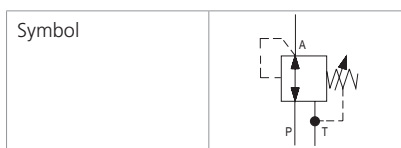

Technical Data

| Valve size / Cartridge cavity | | 3/4-16 UNF-2A / A3 (C-8-3) | | | |
|---|-------------|----------------------------|------------|------------|-------------|
| Max. flow | l/min (GPM) | 20 (5.3) | | | |
| Pressure range | | 2 | 6 | 16 | 21 |
| Max. operating pressure (port P) | bar (PSI) | 50 (730) | 150 (2180) | 250 (3630) | 350 (5100) |
| Reduced pressure range (at Q = 5 l/min) | bar | 10-25 | 20-63 | 50-160 | 100-210 |
| | (PSI) | (150-360) | (290-910) | (730-2320) | (1450-3050) |
| Max. back pressure (port T) | bar (PSI) | 200 (3630) | | | |
| Fluid temperature range (NBR) | °C (°F) | -30 ... +100 (-22 ... 212) | | | |
| Fluid temperature range (FPM) | °C (°F) | -20 ... +120 (-4 ... 248) | | | |
| Weight | kg (lbs) | 0.13 (0.29) | | | |

| | | Datasheet | Type |
|-----------------------------|------------------|-----------|-----------------------------------|
| General information | | HA 0060 | Products and operating conditions |
| Valve bodies | In-line mounted | HA 0018 | SB-A3* |
| | Sandwich mounted | HA 0028 | SB-*-A3* |
| Cavity details / Form tools | | HA 0019 | SMT-A3* |
| Spare parts | | HA 8010 | |

Characteristics measured at $v = 32 \text{ mm}^2/\text{s}$ (156 SUS)

Reducing - relieving pressure related to flow rate

Relieving function A→T / Reducing function P→A

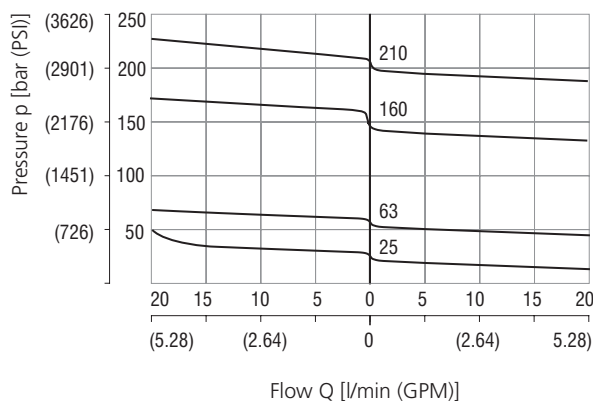

Minimum reducing pressure related to flow rate

Pressure range 6

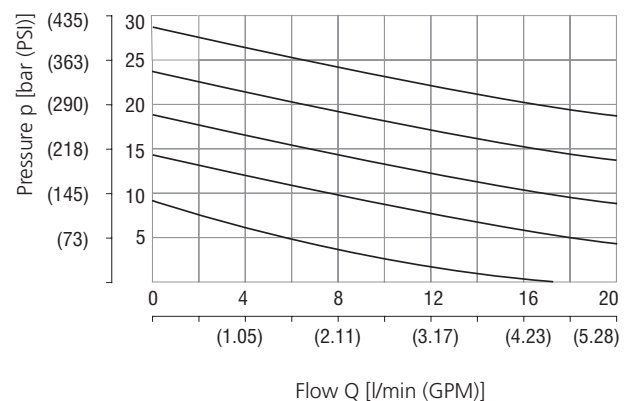

Characteristics measured at $v = 32 \text{ mm}^2/\text{s}$ (156 SUS)

Pressure drop related to flow rate

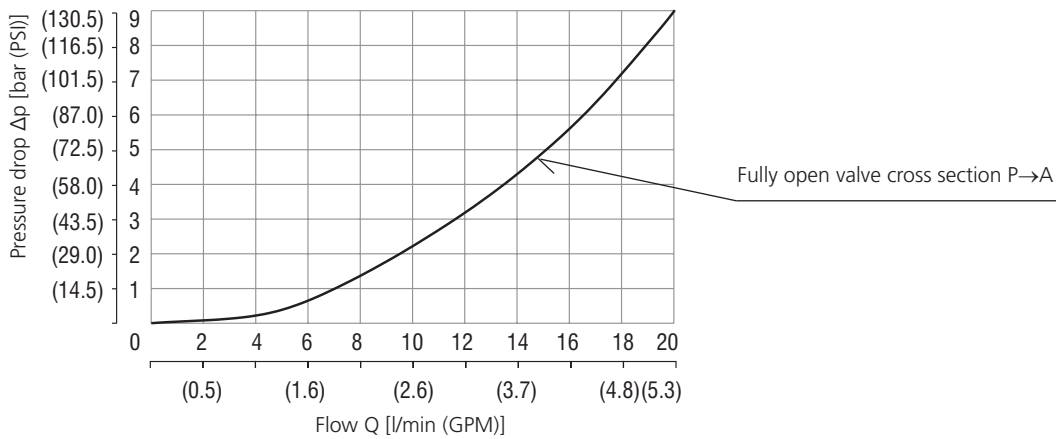

Dimensions in millimeters (inches)

Model S

Model RP

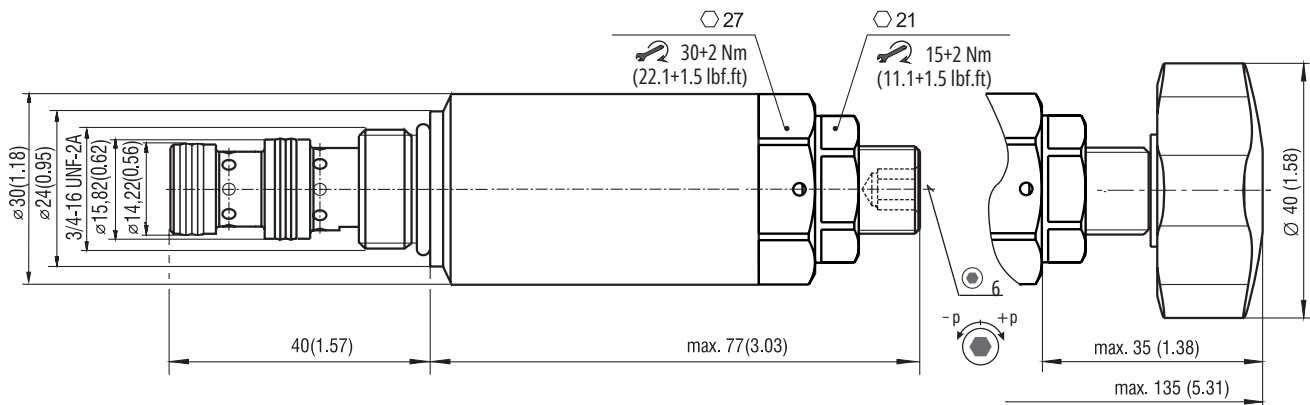

Ordering Code

SP2A - A3 / L -

Pressure reducing - relieving valve, spool type, direct acting

Valve cavity
3/4-16 UNF (C-8-3)

Model
Lightline

Reduced pressure ranges (at Q = 5 l/min)

| | |
|---------------------------------|----|
| 10 - 25 bar (150 - 360 PSI) | 2 |
| 20 - 63 bar (290 - 910 PSI) | 6 |
| 50 - 160 bar (730 - 2320 PSI) | 16 |
| 100 - 210 bar (1450 - 3050 PSI) | 21 |

Surface treatment
A zinc-coated (ZnCr-3), ISO 9227 (240 h)
B zinc-coated (ZnNi), ISO 9227 (520 h)

No designation
V

Seals
NBR
FPM (Viton)

S
RP

Adjustment option
allen key (hex. 6), without protective cap
hand screw, plastic

Model S

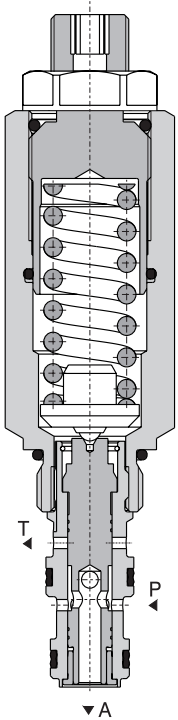

Technical Features

- › Excellent stability throughout flow range with rapid response to dynamic pressure changes
- › Low hysteresis, accurate pressure control and low pressure drop
- › Three-way valve with relief function for protection of actuator against pressure overloading
- › Wide range of input pressure up to 350 bar
- › Precise produced and hardened function parts
- › Reduced pressure adjustable by allen key or hand screw
- › In the standard version, the valve is zinc-coated for 240 h protection acc. to ISO 9227. Enhanced surface protection for mobile sector available for the steel parts (ISO 9227, 520 h salt spray)

Functional Description

Screw-in pressure reducing valve, direct acting, is designed for maintaining the constant pressure in the circuit of actuator, it means for adjusting the force on piston rod or torque on output shaft of hydraulic motor. The spool is a control part of the valve. The output pressure acts on the frontal surface of spool and is permanently compared with the reducing pressure adjusted by screw on the opposite side of the valve. The output pressure is regulated by throttling of input flow from the pump on the control edge of spool. The hydraulic damping of spool moving improves the stability of valve function. If the actuator is overloaded, the spool closes the input of pressure fluid from the pump (P) and unloads the actuator circuit by connecting to the tank (A → T). The actuator is thus protected against pressure overloading.

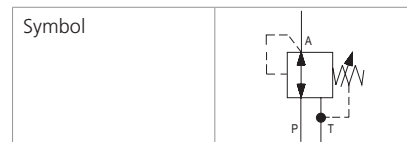

Technical Data

| Valve size / Cartridge cavity | | 3/4-16 UNF-2A / A3 (C-8-3) | | | |
|---|-------------|----------------------------|-----------|------------|-------------|
| Max. flow | l/min (GPM) | 20 (5.3) | | | |
| Pressure range | | 2 | 6 | 16 | 21 |
| Max. operating pressure (port P) | bar (PSI) | 350 (5100) | | | |
| Reduced pressure range (at Q = 5 l/min) | bar | 10-25 | 20-63 | 50-160 | 70-210 |
| | (PSI) | (150-360) | (290-910) | (730-2320) | (1020-3050) |
| Max. back pressure (port T) | bar (PSI) | 200 (3630) | | | |
| Fluid temperature range (NBR) | °C (°F) | -30 ... +100 (-22 ... 212) | | | |
| Fluid temperature range (FPM) | °C (°F) | -20 ... +120 (-4 ... 248) | | | |
| Weight | kg (lbs) | 0.13 (0.29) | | | |

| | | Datasheet | Type |
|-----------------------------|------------------|-----------|-----------------------------------|
| General information | | HA 0060 | Products and operating conditions |
| Valve bodies | In-line mounted | HA 0018 | SB-A3* |
| | Sandwich mounted | HA 0028 | SB-*-A3* |
| Cavity details / Form tools | | HA 0019 | SMT-A3* |
| Spare parts | | HA 8010 | |

Characteristics measured at $v = 32 \text{ mm}^2/\text{s}$ (156 SUS)

Reducing - relieving pressure related to flow rate

Relieving function A→T / Reducing function P→A

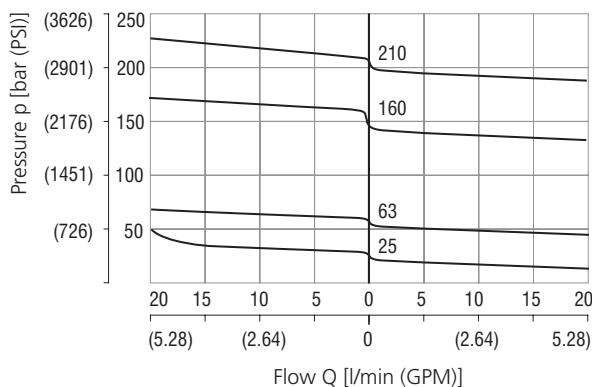

Minimum reducing pressure related to flow rate

Pressure range 6

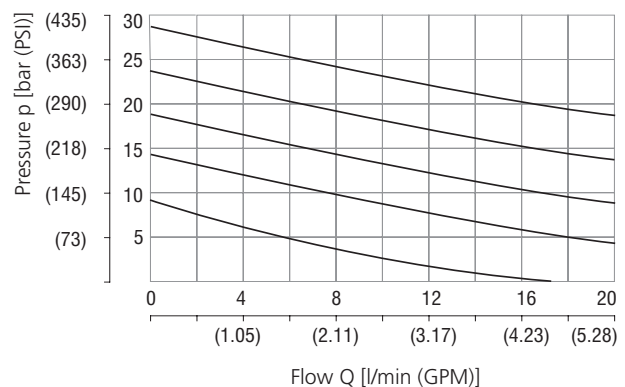

Characteristics measured at $v = 32 \text{ mm}^2/\text{s}$ (156 SUS)

Pressure drop related to flow rate

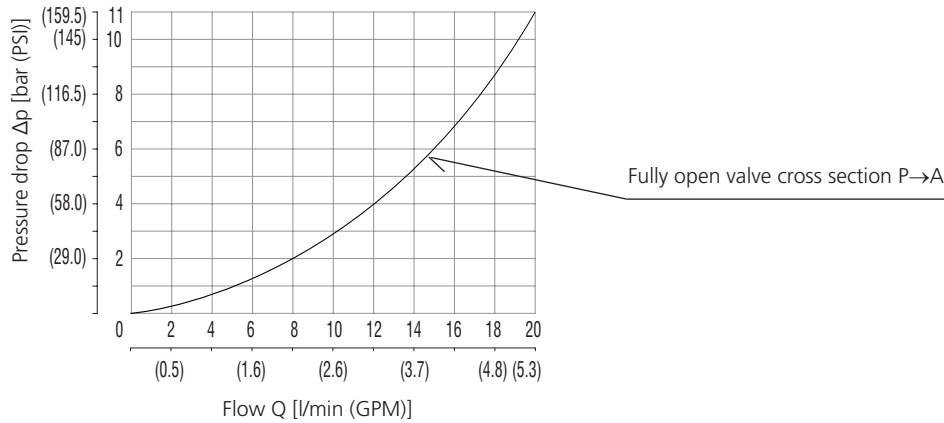

Dimensions in millimeters (inches)

Model S

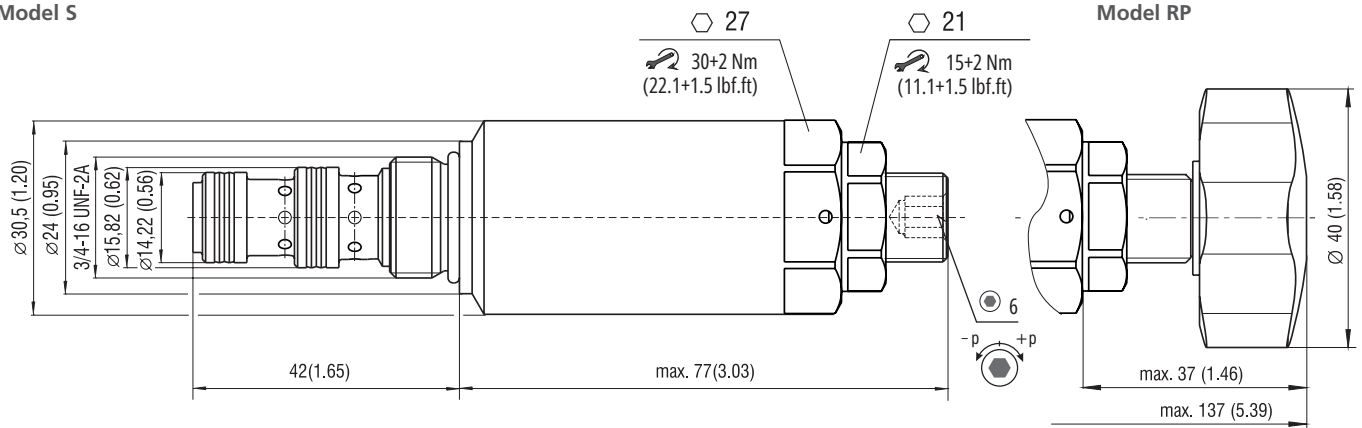

Ordering Code

SP2A - A3 / H -

Pressure reducing - relieving valve, spool type, direct acting

Valve cavity
3/4-16 UNF (C-8-3)

Model
High performance

Reduced pressure ranges (at Q = 5 l/min)

| | |
|--------------------------------|----|
| 10 - 25 bar (150 - 360 PSI) | 2 |
| 20 - 63 bar (290 - 910 PSI) | 6 |
| 50 - 160 bar (730 - 2320 PSI) | 16 |
| 70 - 210 bar (1020 - 3050 PSI) | 21 |

Surface treatment
A zinc-coated (ZnCr-3), ISO 9227 (240 h)
B zinc-coated (ZnNi), ISO 9227 (520 h)

No designation
V

Seals
NBR
FPM (Viton)

S
RP

Adjustment option
allen key (hex. 6), without protective cap
hand screw, plastic

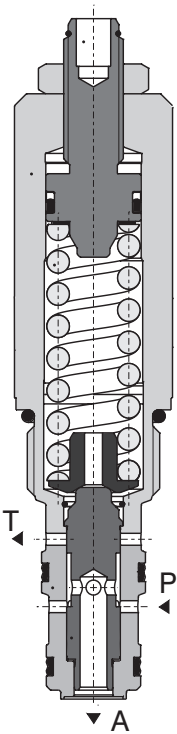

Technical Features

- › Excellent stability throughout flow range with rapid response to dynamic pressure changes
- › Low hysteresis, accurate pressure control and low pressure drop
- › Wide pressure range up to 420 bar
- › Hardened precision parts
- › Adjustable by allen key or hand screw
- › In the standard version, the valve is zinc-coated for 520 h protection acc. to ISO 9227

Functional Description

The valve provides an adjustable regulated pressure level below supply pressure. This direct acting model is suitable for applications with lower flow rates and lower regulated pressures. In cases of shock or surge pressures in the downstream line the valve acts as a relief valve, directing excessive pressure and flow to the tank.

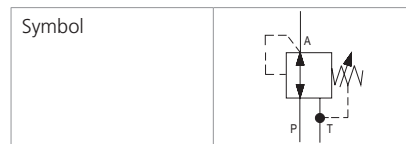

Technical Data

| Valve size / Cartridge cavity | | 7/8-14 UNF-2A / B3 (C-10-3) | | | |
|---|-------------|-----------------------------|------------------|-------------------|-------------------|
| Max. flow | l/min (GPM) | 60 (15.9) | | | |
| Pressure range | | 3 | 8 | 11 | 15 |
| Max. operating pressure | bar (PSI) | 420 (6100) | | | |
| Reduced pressure range (at Q = 5 l/min) | bar (PSI) | 10-30 (150-440) | 20-80 (290-1160) | 30-110 (440-1600) | 40-150 (580-2180) |
| Max. back pressure (port T) | bar (PSI) | 200 (3626) | | | |
| Fluid temperature range (NBR) | °C (°F) | -30 ... +100 (-22 ... 212) | | | |
| Fluid temperature range (FPM) | °C (°F) | -20 ... +120 (-4 ... 248) | | | |
| Weight | kg (lbs) | 0.26 (0.57) | | | |

| | | Datasheet | Type |
|-----------------------------|------------------|-----------|-----------------------------------|
| General information | | HA 0060 | Products and operating conditions |
| Valve bodies | In-line mounted | HA 0018 | SB-B3* |
| | Sandwich mounted | HA 0028 | SB-*-B3* |
| Cavity details / Form tools | | HA 0019 | SMT-B3* |
| Spare parts | | HA 8010 | |

Characteristics measured at $v = 32 \text{ mm}^2/\text{s}$ (156 SUS)

Reducing - relieving pressure related to flow rate

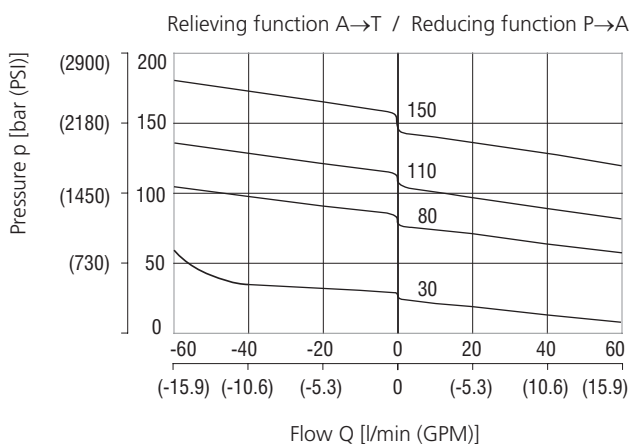

Minimum reducing pressure related to flow rate

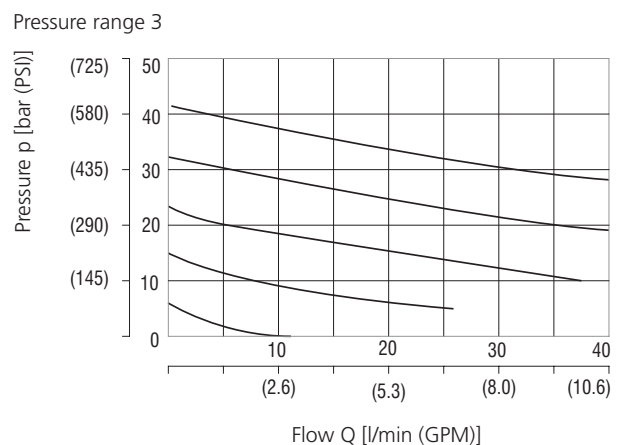

Characteristics measured at $v = 32 \text{ mm}^2/\text{s}$ (156 SUS)

Pressure drop related to flow rate

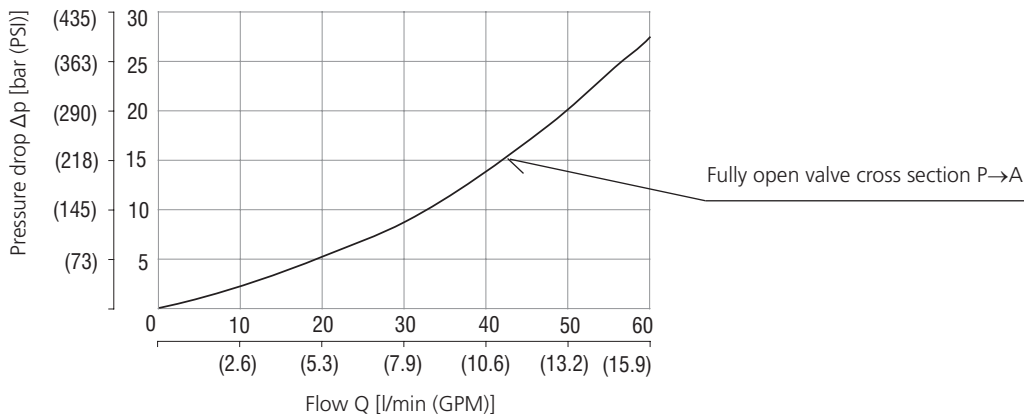

Dimensions in millimeters (inches)

Model S

Model RP

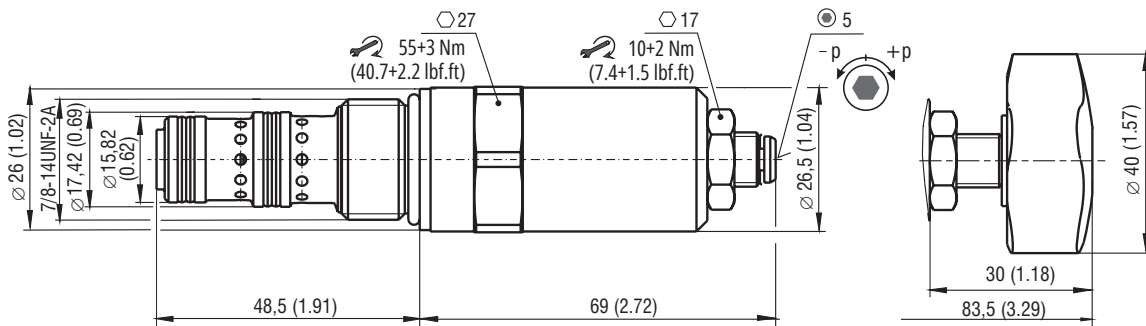

Ordering Code

SP2A-B3 / H **- B**

Pressure reducing - relieving valve, spool type, direct acting

Valve cavity
7/8-14 UNF (C-10-3)

Model
High performance

Reduced pressure range (at Q = 5 l/min)

| | |
|-----------------------------------|-----------|
| 10 ... 30 bar (150 ... 440 PSI) | 3 |
| 20 ... 80 bar (290 ... 1160 PSI) | 8 |
| 30 ... 110 bar (440 ... 1600 PSI) | 11 |
| 40 ... 150 bar (580 ... 2180 PSI) | 15 |

Surface treatment
zinc-coated (ZnNi), ISO 9227 (520 h)

No designation
V

Seals
NBR
FPM (Viton)

Adjustment option
allen key (hex. 5), without protective cap
hand screw, plastic

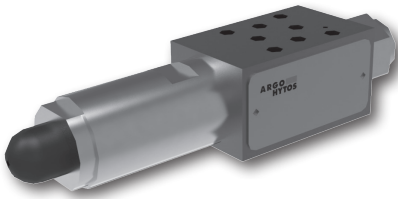

Technical Features

- › Pressure reducing - relieving valve, spool type, direct acting, with mounting interface acc. to ISO 4401, DIN 24340 (CETOP 02)
- › Excellent stability throughout flow range with rapid response to dynamic pressure changes
- › Low hysteresis, accurate pressure control and low pressure drop
- › Wide pressure range up to 320 bar
- › Hardened precision parts
- › Pressure reduction function in ports P, A, or B
- › Adjustable by allen key or hand screw
- › Good adjustment sensitivity with reduced drainage flow
- › In the standard version, the valve housing is phosphated for basic surface corrosion protection and as preparation for painting. Steel parts are zinc-coated for 240 h salt spray protection acc. to ISO 9227
- › Enhanced surface protection for mobile sector available for the valve housing and steel parts (ISO 9227, 520 h salt spray)

Technical Data

| | | | | | |
|---|---|---|-----------|------------|------------|
| Valve size | 04 (D02) | | | | |
| Max. flow | l/min (GPM) 20 (5.3) | | | | |
| Max. operating pressure (ports P, A, B) | bar (PSI) 320 (4600) | | | | |
| Max. operating pressure (port T) | bar (PSI) 210 (3050) | | | | |
| Reduced pressure range (at Q = 5 l/min) | bar | 10-25 | 20-63 | 30-160 | 50-210 |
| | (PSI) | (150-360) | (290-910) | (440-2320) | (730-3050) |
| Fluid temperature range (NBR) | °C (°F) -30 +100 (-22 ... +212) | | | | |
| Fluid temperature range (FPM) | °C (°F) -20 +120 (-4 ... +248) | | | | |
| Weight - model "A" | kg (lbs) 0.82 (1.81) | | | | |
| | - model "B", "P" 0.60 (1.32) | | | | |
| | Datasheet | Type | | | |
| General information | HA 0060 | Products and operating conditions | | | |
| Mounting interface | HA 0019 | ISO 4401-02-01-0-05 DIN 24340 (CETOP 02) | | | |
| Spare parts | HA 8010 | | | | |

ISO 4401-02-01-0-05

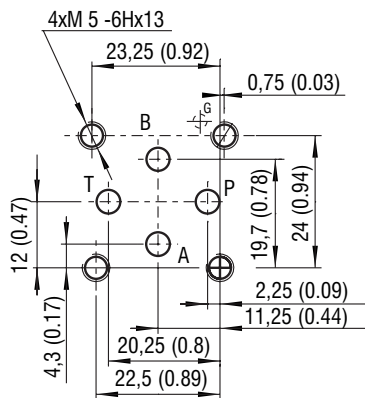

Ports P, A, B, T - max. \varnothing 4.5 mm (0.18 in)

Functional Description

The pressure valves VRP2 are directly operated reducing-relieving valves for vertical stacking assemblies designed as 3 way valves, which means it includes pressure protection of the secondary circuit. The valve consists of the valve body, control spool, spring, and adjustment element. The body includes a port M with thread G 1/4 for attachment of a pressure measuring device or a by-pass free flow check valve.

Model A

In model A, the fluid enters the valve body from the primary circuit through port A1 and passes through the metering edge, where its pressure is reduced. The flow is passed to the output port A2 and on to the user. The reverse free flow from port A2 to port A1 passes through a check valve which is connected in parallel to the metering edge of the control spool.

Model B

In model B, the pressure reduction occurs from port P2 to port P1, but only if the flow in port B passes towards the user (not opposite). The protection of the secondary circuit is therefore ensured for one flow direction only.

Model P

In model P, the pressure reduction occurs from port P2 to port P1, and is effective in both flow directions through the directional valve. Therefore, the protection of the secondary circuit is ensured for both flow directions.

Characteristics measured at $v = 32 \text{ mm}^2/\text{s}$ (156 SUS)

Reducing - relieving pressure related to flow rate

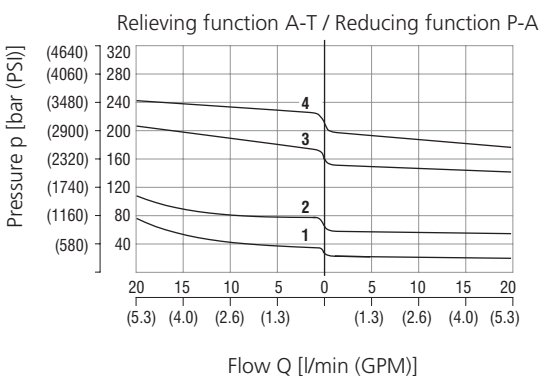

| | Pressure range |
|---|----------------|
| 4 | 21 |
| 3 | 16 |
| 2 | 6 |
| 1 | 2 |

Pressure drop related to flow rate

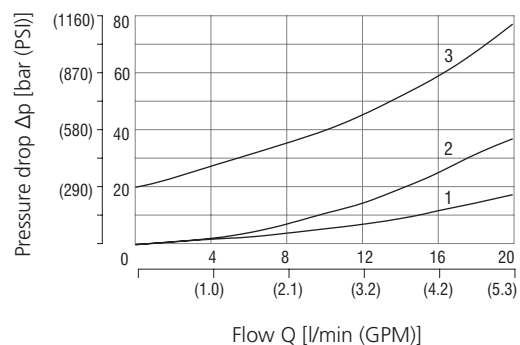

- 1 - Pressure drop of check valve
- 2 - Pressure drop of reducing valve at min. adjustable pressure range
- 3 - Pressure drop of relief valve at min. adjustable safety pressure

| | Direction | |
|---|-----------|-------------|
| | Model A | Models P, B |
| 3 | A2-T | P1-T |
| 2 | A1-A2 | P2-P1 |
| 1 | A2-A1 | |

Dimensions in millimeters (inches)

Type „A“

Model T

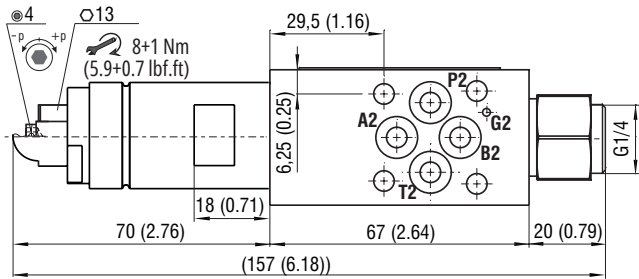

Model RS

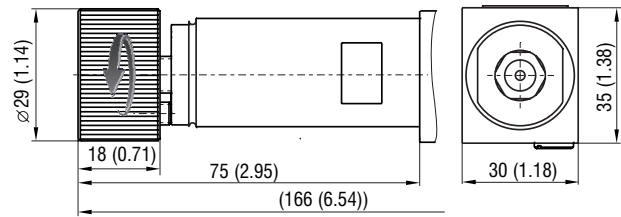

Type „B“ and „P“

Model T

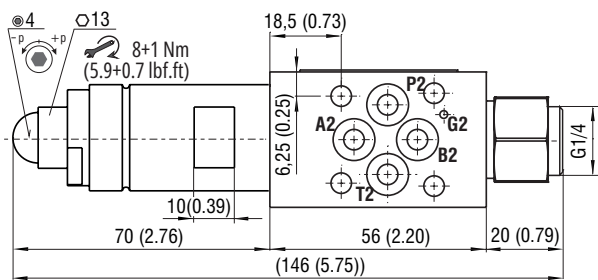

Model RS

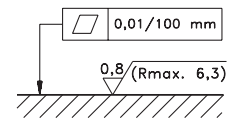
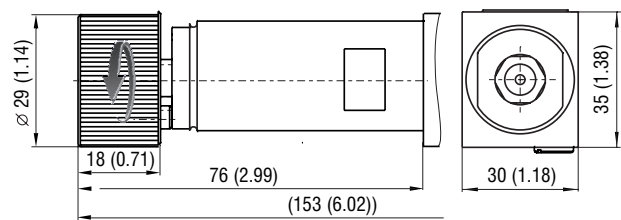

Required surface quality of the counterpart

Functional symbols

VRP2-04-A*

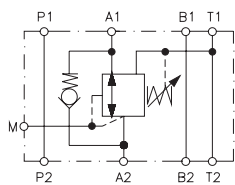

VRP2-04-B*

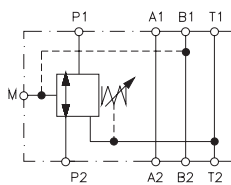

VRP2-04-P*

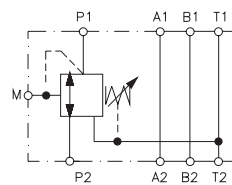

① valve side

② subplate or manifold side

Notice: The orientation of the symbol on the name plate corresponds with the valve function.

Ordering Code

VRP2 - 04 - [] [] / [] [] - []

Pressure reducing - relieving valve, spool type, direct acting, modular

Valve size
ISO 4401-02-01-0-05, DIN 24340 (CETOP 02), size 04

Model

Pressure reduction
on port A2
on port P1
on port P1

Pressure sensing
at port A2
at port B1
at port P1

A
B
P

T
RS

No designation
A
B

Surface treatment
standard
zinc-coated (ZnCr-3), ISO 9227 (240 h)
zinc-coated (ZnNi), ISO 9227 (520 h)

No designation
V

Seals
NBR
FPM (Viton)

Reduced pressure range (at Q = 5 l/min)
2 10 - 25 bar (150 - 360 PSI)
6 20 - 63 bar (290 - 910 PSI)
16 30 - 160 bar (440 - 2320 PSI)
21 50 - 210 bar (730 - 3050 PSI)

Adjustment option
allen key (hex. 4), with protective cap
hand screw, metal

Technical Features

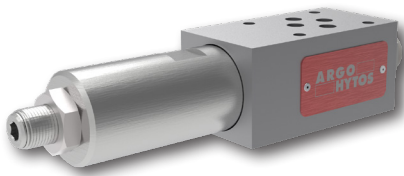

- › Pressure reducing - relieving valve, spool type, direct acting, with mounting interface acc. to ISO 4401, DIN 24340 (CETOP 03)
- › Excellent stability throughout flow range with rapid response to dynamic pressure changes
- › Low hysteresis, accurate pressure control and low pressure drop
- › Wide pressure range up to 350 bar
- › High flow capacity
- › Hardened precision parts
- › Pressure reduction function in ports P, A, or B
- › Adjustable by allen key or hand screw
- › Good adjustment sensitivity with reduced drainage flow
- › In the standard version, the valve housing is phosphated for basic surface corrosion protection and as preparation for painting. Steel parts are zinc-coated for 240 h salt spray protection acc. to ISO 9227
- › Enhanced surface protection for mobile sector available for the valve housing and steel parts (ISO 9227, 520 h salt spray)

ISO 4401-03-02-0-05

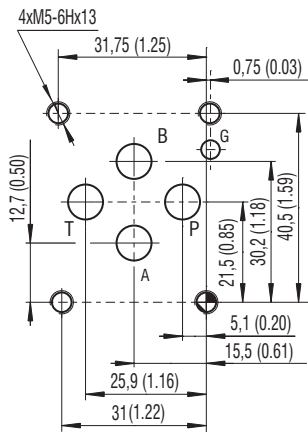

Ports P, A, B, T - max. \varnothing 7.5 mm (0.29 in)

Technical Data

| | | | | |
|---|-------------|---|-----------|------------|
| Valve size | 06 (D03) | | | |
| Max. flow | l/min (GPM) | | | |
| Max. operating pressure (ports P, A, B) | bar (PSI) | | | |
| Max. operating pressure (port T) | bar (PSI) | | | |
| Reduced pressure range (at $Q = 5$ l/min) | bar | 10-25 | 20-63 | 30-160 |
| | (PSI) | (150-360) | (290-910) | (440-2320) |
| Fluid temperature range (NBR) | °C (°F) | -30 ... +100 (-22 ... +212) | | |
| | °C (°F) | -20 ... +120 (-4 ... +248) | | |
| Weight - model "A", "E" | kg (lbs) | 1.75 (3.85) | | |
| | | - model "B", "P" | | |
| | Datasheet | Type | | |
| General information | HA 0060 | Products and operating conditions | | |
| Mounting interface | HA 0019 | ISO 4401-03-02-0-05 DIN 24340 (CETOP 03) | | |
| Spare parts | HA 8010 | | | |

Functional Description

The pressure valves VRP2 are directly operated reducing-relieving valves for vertical stacking assemblies designed as 3 way valves, which means it includes pressure protection of the secondary circuit. The valve consists of the valve body, control spool, spring, and adjustment element. The body includes a port M with thread G 1/4 for attachment of a pressure measuring device or a by-pass free flow check valve.

Model A

In model A, the fluid enters the valve body from the primary circuit through port A1 and passes through the metering edge, where its pressure is reduced. The flow is passed to the output port A2 and on to the user. The reverse free flow from port A2 to port A1 passes through a check valve which is connected in parallel to the metering edge of the control spool.

Model E

In model E, the fluid enters the valve body from the primary circuit through port B1 and passes through the metering edge, where its pressure is reduced. The flow is passed to the output port B2 and on to the user. The reverse free flow from port B2 to port B1 passes through a check valve which is connected parallel to the metering edge of the control spool.

Model B

In model B, the pressure reduction occurs from port P2 to port P1, but only if the flow in port B passes towards the user (not opposite). The protection of the secondary circuit is therefore ensured for one flow direction only.

Model P

In model P, the pressure reduction occurs from port P2 to port P1, and is effective in both flow directions through the directional valve. Therefore, the protection of the secondary circuit is ensured for both flow directions.

Functional symbols

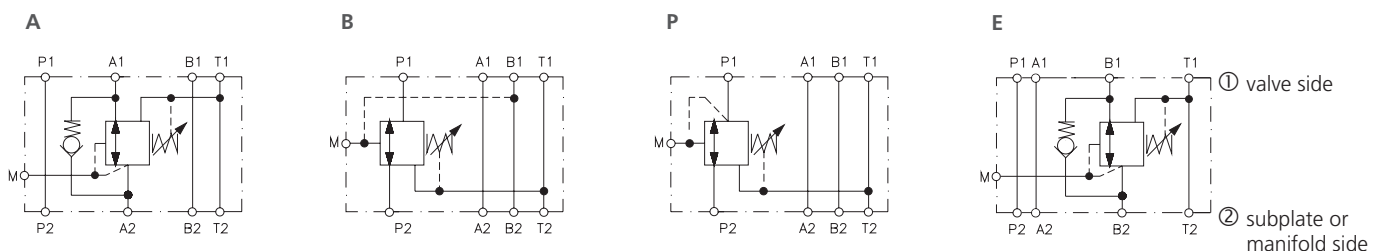

Notice: The orientation of the symbol on the name plate corresponds with the valve function.

Dimensions in millimeters (inches)

Model A, B, P

Typ S

| Dimensions | A | C | B |
|---------------|-------------|-----------|--------------|
| Model A and E | 90.0 (3.54) | 45 (1.77) | (199) (7.83) |
| Model B and P | 84.5 (3.33) | 40 (1.57) | (193) (7.60) |

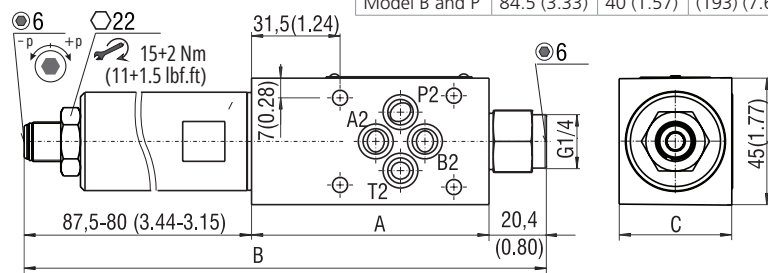

Typ T

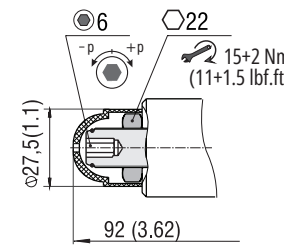

Typ RP

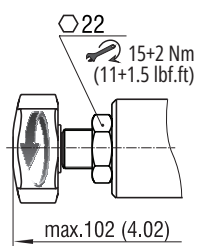

Model E

Typ S

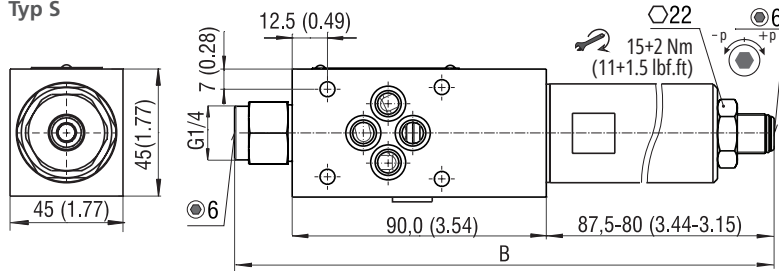

Typ T

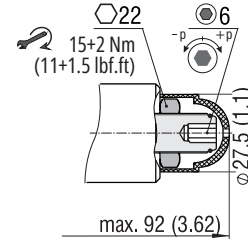

Typ RP

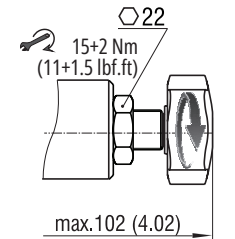

Required surface quality of the counterpart $0,01/100 \text{ mm}$
 $0,8 / (R_{\text{max. } 6,3})$

Characteristics measured at $v = 32 \text{ mm}^2/\text{s}$ (156 SUS)

Reducing - relieving pressure related to flow rate

Relieving function A-T / Reducing function P-A

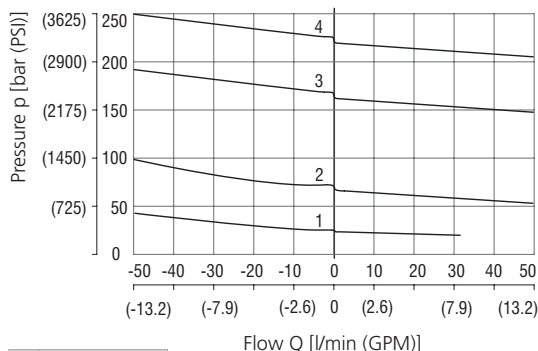

| Pressure range | |
|----------------|----|
| 4 | 21 |
| 3 | 16 |
| 2 | 6 |
| 1 | 2 |

Pressure drop related to flow rate

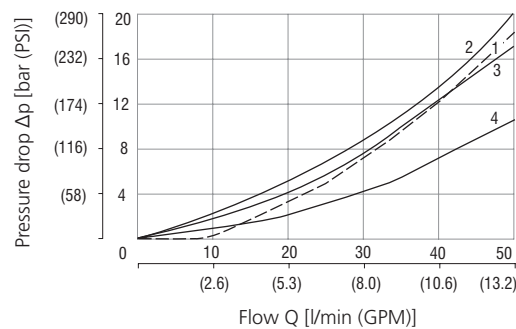

| | Flow direction - Model | | | |
|---|------------------------|-------|-------|-------|
| | A | B | E | P |
| 4 | A1-A2 | | B1-B2 | |
| 3 | A2-A1 | | B2-B1 | |
| 2 | A2-T | P1-T | B2-T | P1-T |
| 1 | | P2-P1 | | P2-P1 |

- 1 (4) - Pressure drop of reducing valve at min. adjustable pressure range
- 2 - Pressure drop of relief valve at min. adjustable safety pressure
- 3 - Pressure drop of check valve

Ordering Code

VRP2 - 06 - [] / [] - []

Pressure reducing - relieving valve, spool type, direct acting, modular

Valve size
ISO 4401-03-02-0-05, DIN 24340 (CETOP 03), size 06

Model

Pressure reduction
on port A2
on port P1
on port B2
on port P1

Pressure sensing
at port A2
at port B1
at port B2
at port P1

A
B
E
P

S
T
RP

No designation
A zinc-coated (ZnCr-3), ISO 9227 (240 h)
B zinc-coated (ZnNi), ISO 9227 (520 h)

Surface treatment
standard
zinc-coated (ZnCr-3), ISO 9227 (240 h)
zinc-coated (ZnNi), ISO 9227 (520 h)

No designation
V

Seals
NBR
FPM (Viton)

Pressure range range (at Q = 5 l/min)
10 - 25 bar (150 - 360 PSI)
20 - 63 bar (290 - 910 PSI)
30 - 160 bar (440 - 2320 PSI)
40 - 210 bar (580 - 3050 PSI)

Adjustment option
allen key (hex. 6), without protective cap
allen key (hex. 6), with protective cap
hand screw, plastic*

*For pressure ranges 16 and 21 is possible to adjust reduced pressure only in circuit without pressure

Pressure Reducing Valve, Spool Type, Pilot Operated

SP4A-B3

7/8-14 UNF • Q_{max} 60 l/min (16 GPM) • p_{max} 350 bar (5100 PSI)

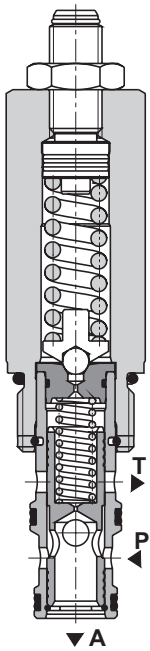

Technical Features

- › Excellent stability throughout flow range with rapid response to dynamic pressure changes
- › Low hysteresis, accurate pressure control and low pressure drop by CFD optimized flow path
- › Reverse relief protection
- › Wide pressure range up to 350 bar
- › High flow capacity
- › Hardened precision parts
- › Adjustable by allen key or hand screw
- › In the standard version, the valve is zinc-coated for 240 h protection acc. to ISO 9227.
Enhanced surface protection for mobile sector available for the steel parts (ISO 9227, 520 h salt spray)

Functional Description

This 3 way pilot operated pressure reducing valve is designed to reduce the system pressure at the consumer port. Due to its 3 way design the valve provides reverse relief protection of the secondary circuit to the tank port. The pressure can be set by an adjustment screw (by allen key or by hand screw).



Technical Data

| Valve size / Cartridge cavity | | 7/8-14 UNF-2A / B3 (C-10-3) |
|-----------------------------------|------------------|-----------------------------|
| Max. flow | l/min (GPM) | 60 (15.9) |
| Max. control flow | l/min (GPM) | 0.34 (0.09) |
| Max. operating pressure | bar (PSI) | 350 (5100) |
| Max. pressure (port T) | bar (PSI) | 100 (1450) |
| Fluid temperature range (NBR) | °C (°F) | -30 ... +100 (-22 ... 212) |
| Fluid temperature range (FPM) | °C (°F) | -20 ... +120 (-4 ... 248) |
| Weight | kg (lbs) | 0.24 (0.53) |
| Datasheet | | Type |
| General information | | HA 0060 |
| Products and operating conditions | | |
| Valve bodies | In-line mounted | HA 0018 |
| | Sandwich mounted | HA 0028 |
| Cavity details / Form tools | | HA 0019 |
| Spare parts | | HA 8010 |
| | | SMT-B3* |



The volume flow, which is needed for control of output pressure and maintaining the adjusted value of reducing pressure, flows permanently through the pilot stage of valve.

Characteristics measured at $v = 32 \text{ mm}^2/\text{s}$ (156 SUS)

Reducing - relieving pressure related to flow rate

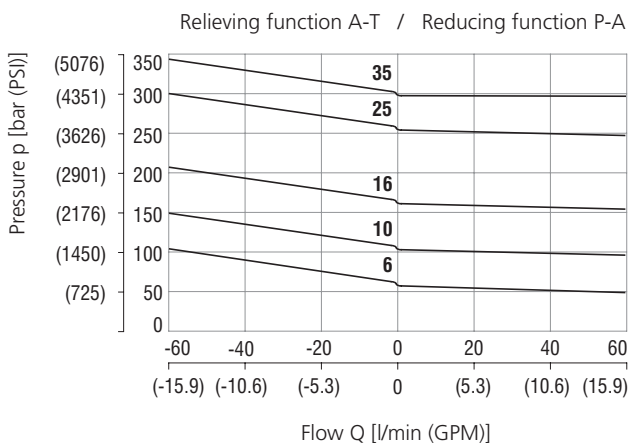

Pressure drop related to flow rate

Flow direction P - A
Fully open valve cross section

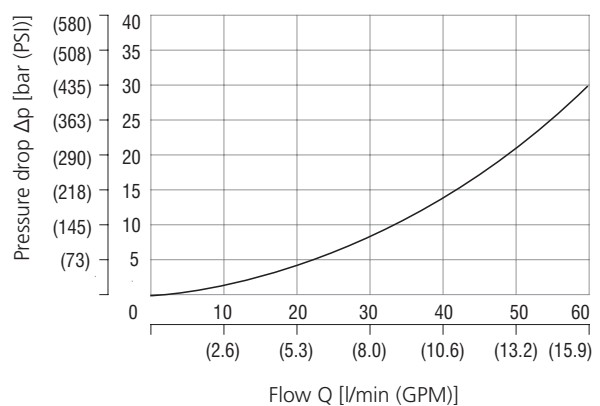

Dimensions in millimeters (inches)

Model S

Model T

Model RP

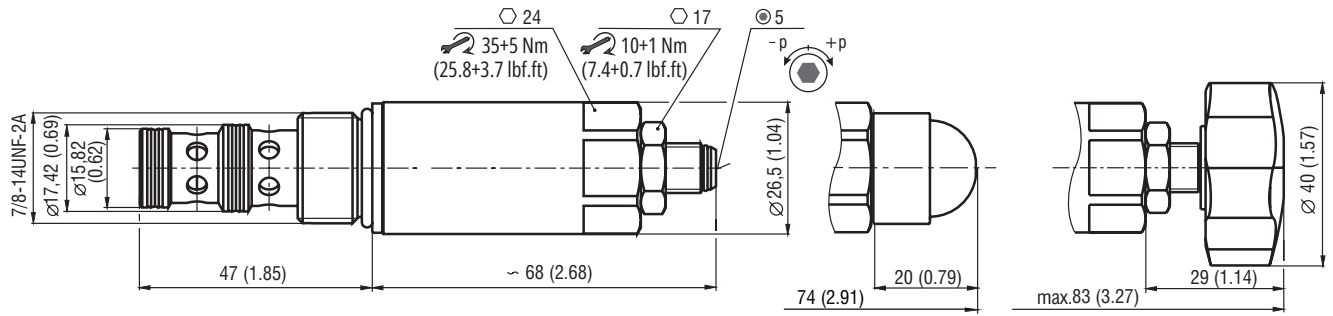

Ordering Code

SP4A-B3 / H

Pressure reducing - relieving valve,
spool type, pilot operated

Valve cavity

7/8-14 UNF (C-10-3)

Model

High performance

Adjustable range of reduced pressure

10 ... 63 bar (145 ... 910 PSI)

6

10 ... 100 bar (145 ... 1450 PSI)

10

10 ... 160 bar (145 ... 2320 PSI)

16

10 ... 250 bar (145 ... 3630 PSI)

25

10 ... 350 bar (145 ... 5080 PSI)

35

Surface treatment
A zinc-coated (ZnCr-3), ISO 9227 (240 h)
B zinc-coated (ZnNi), ISO 9227 (520 h)

No designation
V

Seals
NBR
FPM (Viton)

S
T
RP

Adjustment option
allen key (hex. 5), without protective cap
allen key (hex. 5), with protective cap
hand screw, plastic

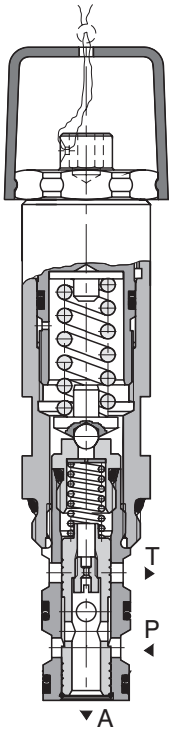

Technical Features

- › Excellent stability throughout flow range with rapid response to dynamic pressure changes
- › Low hysteresis, accurate pressure control and low pressure drop
- › Reverse relief protection
- › Wide pressure range up to 320 bar
- › High flow capacity
- › Hardened precision parts
- › Adjustable by allen key or hand screw, optionally sealable (lockwire holes)
- › In the standard version, the valve is zinc-coated for 240 h protection acc. to ISO 9227. Enhanced surface protection for mobile sector available for the steel parts (ISO 9227, 520 h salt spray)

Functional Description

This 3 way pilot operated pressure reducing valve is designed to reduce the system pressure at the consumer port. Due to its 3 way design the valve provides reverse relief protection of the secondary circuit to the tank port. The pressure can be set by an adjustment screw (by allen key or by hand screw) and the valve is optionally equipped with lockwire holes for sealing.

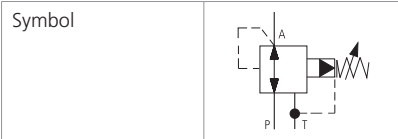

Technical Data

| | | |
|-------------------------------|------------------|-----------------------------------|
| Valve size / Cartridge cavity | | M22 x 1,5 / QF3 |
| Max. flow | l/min (GPM) | 40 (10.6) |
| Max. control flow | l/min (GPM) | 0.25 (0.07) |
| Max. operating pressure | bar (PSI) | 320 (4600) |
| Max. pressure (T port) | bar (PSI) | 160 (2320) |
| Fluid temperature range (NBR) | °C (°F) | -30 ... +100 (-22 ... 212) |
| Fluid temperature range (FPM) | °C (°F) | -20 ... +120 (-4 ... 248) |
| Weight | kg (lbs) | 0.22 (0.49) |
| Datasheet | | Type |
| General information | | HA 0060 |
| | | Products and operating conditions |
| Valve bodies | In-line mounted | HA 0018 |
| | Sandwich mounted | HA 0028 |
| Cavity details | | SB-QF3* |
| | | SB-04(06)-QF3* |
| Spare parts | | SMT-QF3* |
| | | HA 8010 |



The volume flow, which is needed for control of output pressure and maintaining the adjusted value of reducing pressure, flows permanently through the pilot stage of valve.

Characteristics measured at $v = 32 \text{ mm}^2/\text{s}$ (156 SUS)

Reducing - relieving pressure related to flow rate

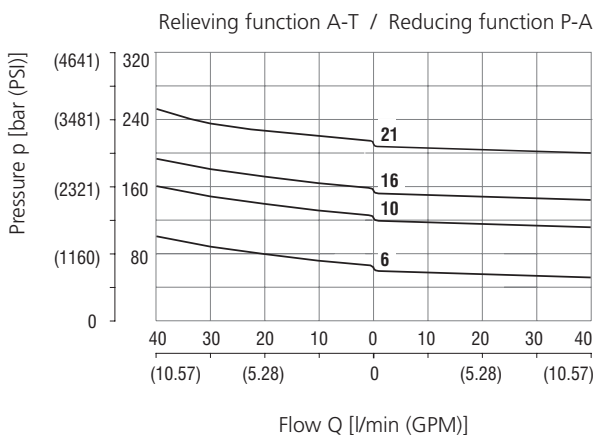

Pressure drop related to flow rate

Flow direction P-A
Fully open valve cross section

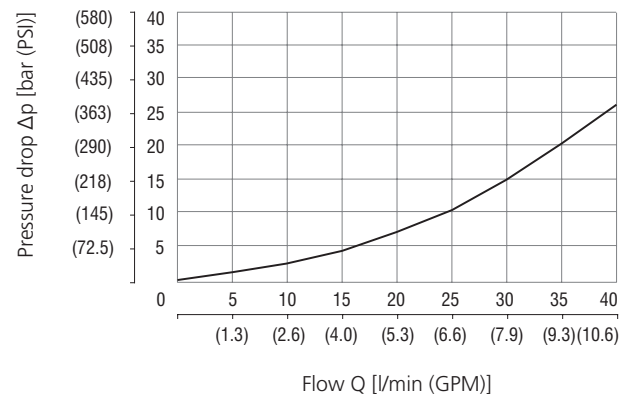

Dimensions in millimeters (inches)

Model S

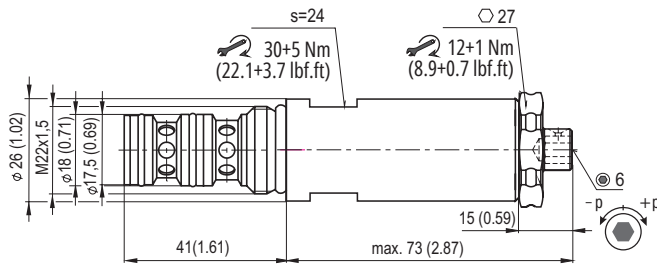

Model RS

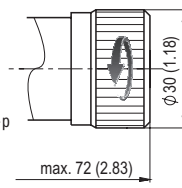

Model RP

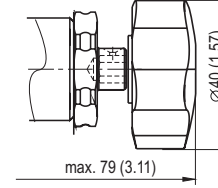

Model L

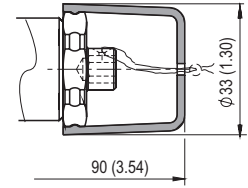

Ordering Code

VRN2-06 / S - [] [] [] - []

Pressure reducing - relieving valve,
spool type, pilot operated M22 x 1,5

Model
screw-in cartridge

Adjustable range of reduced pressure

| | |
|-----------------------------------|----|
| 10 ... 63 bar (145 ... 910 PSI) | 6 |
| 10 ... 100 bar (145 ... 1450 PSI) | 10 |
| 10 ... 160 bar (145 ... 2320 PSI) | 16 |
| 10 ... 210 bar (145 ... 3050 PSI) | 21 |

Surface treatment

| | |
|---|--|
| A | zinc-coated (ZnCr-3), ISO 9227 (240 h) |
| B | zinc-coated (ZnNi), ISO 9227 (520 h) |

Seals

| | |
|---|-------------|
| V | NBR |
| | FPM (Viton) |

Adjustment option

| | |
|----|--|
| S | allen key (hex. 6), without protective cap |
| RS | hand screw, metal |
| RP | hand screw, plastic |
| L | allen key (hex. 6), with protective cap, sealable (lockwire holes) |

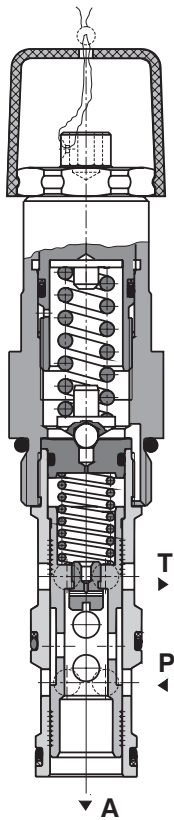

Technical Features

- › Excellent stability throughout flow range with rapid response to dynamic pressure changes
- › Low hysteresis, accurate pressure control and low pressure drop
- › Reverse relief protection
- › Wide pressure range up to 320 bar
- › High flow capacity
- › Hardened precision parts
- › Adjustable by allen key or hand screw, optionally sealable (lockwire holes)
- › In the standard version, the valve is zinc-coated for 240 h protection acc. to ISO 9227. Enhanced surface protection for mobile sector available for the steel parts (ISO 9227, 520 h salt spray)

Functional Description

This 3 way pilot operated pressure reducing valve is designed to reduce the system pressure at consumer port. Due to its 3 way design the valve provides reverse relief protection of the secondary circuit to the tank port. The pressure can be set by an adjustment screw (by allen wrench or by hand) and the valve is optionally equipped with lockwire holes for sealing.

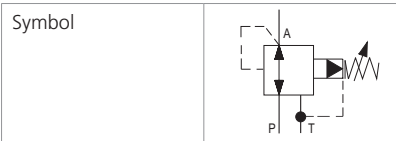

Technical Data

| | | |
|-----------------------------------|-----------------|----------------------------|
| Valve size / Cartridge cavity | | M27x2 / K3 |
| Max. flow | l/min (GPM) | 150 (39.6) |
| Max. control flow | l/min (GPM) | 0.65 (0.17) |
| Max. operating pressure | bar (PSI) | 320 (4600) |
| Max. pressure (port T) | bar (PSI) | 160 (2320) |
| Fluid temperature range (NBR) | °C (°F) | -30 ... +100 (-22 ... 212) |
| Fluid temperature range (FPM) | °C (°F) | -20 ... +120 (-4 ... 248) |
| Weight | kg (lbs) | 0.35 (0.77) |
| Datasheet | | Type |
| General information | | HA 0060 |
| Products and operating conditions | | |
| Valve bodies | In-line mounted | HA 0018 |
| | | SB-K3* |
| Cavity details | | HA 0029 |
| | | SMT-K3* |
| Spare parts | | HA 8010 |



The volume flow, which is needed for control of output pressure and maintaining the adjusted value of reducing pressure, flows permanently through the pilot stage of valve.

Characteristics measured at $v = 32 \text{ mm}^2/\text{s}$ (156 SUS)

Reducing - relieving pressure related to flow rate

Relieving function A-T / Reducing function P-A

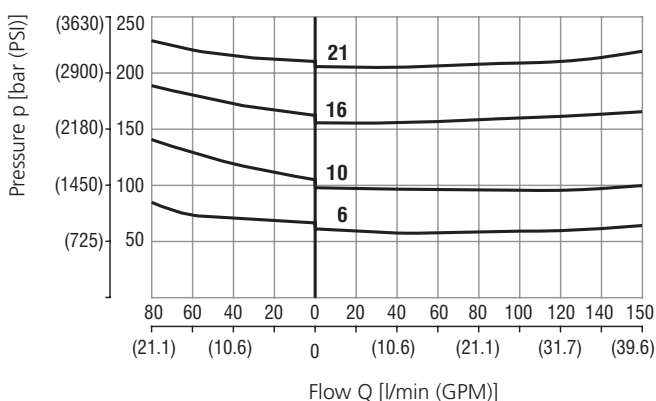

Pressure drop related to flow rate

Flow direction P-A
Fully open valve cross section

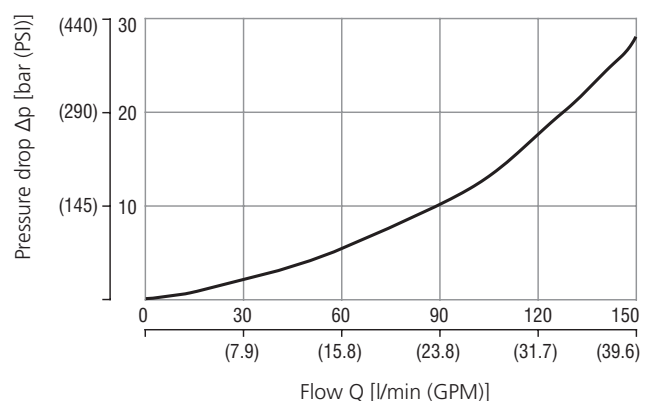

Dimensions in millimeters (inches)

Model S

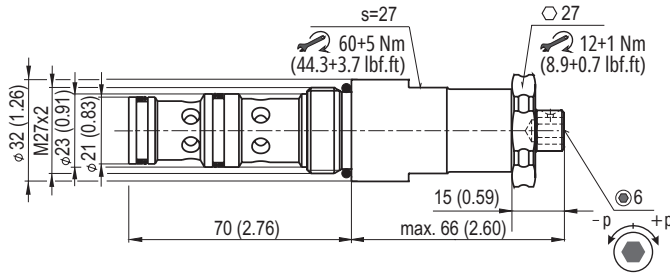

Model RS

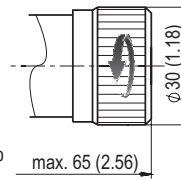

Model RP

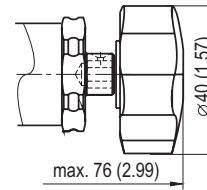

Model L

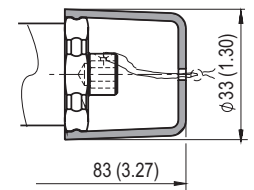

Ordering Code

VRN2-10 / S - [] [] [] - []

Pressure reducing - relieving valve,
spool type, pilot operated M27x2

Model
screw-in cartridge

Adjustable range of reduced pressure

| | |
|-----------------------------------|----|
| 10 ... 63 bar (145 ... 910 PSI) | 6 |
| 10 ... 100 bar (145 ... 1450 PSI) | 10 |
| 10 ... 160 bar (145 ... 2320 PSI) | 16 |
| 10 ... 210 bar (145 ... 3050 PSI) | 21 |

Surface treatment

| | |
|---|--|
| A | zinc-coated (ZnCr-3), ISO 9227 (240 h) |
| B | zinc-coated (ZnNi), ISO 9227 (520 h) |

No designation
V

Seals
NBR
FPM (Viton)

Adjustment option

| | |
|----|--|
| S | allen key (hex. 6), without protective cap |
| RS | hand screw, metal |
| RP | hand screw, plastic |
| L | allen key (hex. 6), with protective cap, sealable (lockwire holes) |

VRN2-06/M(R)

Size 06 (D03) • Q_{max} 40 l/min (11 GPM) • p_{max} 320 bar (4600 PSI)

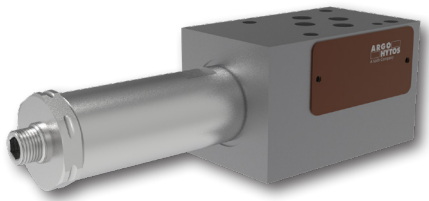

Technical Features

- › Pressure reducing - relieving valve, spool type, pilot operated with mounting interface acc. to ISO 4401, DIN 24340 (CETOP 03)
- › Excellent stability throughout flow range with rapid response to dynamic pressure changes
- › Low hysteresis, accurate pressure control and low pressure drop
- › Reverse relief protection
- › Wide pressure range up to 320 bar
- › High flow capacity
- › Hardened precision parts
- › Adjustable by allen key or hand screw, optionally sealable (lockwire holes)
- › In the standard version, the valve housing is phosphated for basic surface corrosion protection and as preparation for painting. Steel parts are zinc-coated for 240 h salt spray protection acc. to ISO 9227
- › Enhanced surface protection for mobile sector available for the valve housing and steel parts (ISO 9227, 520 h salt spray)

Functional Description

This pilot operated pressure reducing valve is designed to reduce the system pressure at the consumer port. Its 3 way design provides reverse relief protection of the secondary circuit to the tank port. The pressure can be set by an adjustment screw and the valve is optionally equipped with lockwire holes for sealing. Valve bodies for vertical stacking assemblies are available with pressure reduction in ports A and P. Check valves incorporated into the valve bodies MA(B) enable the reverse flow to pass freely through the valve.

Model MA, MB, MC

In models MA and MB, the flow enters the valve through port A1 (B1). The input pressure is reduced and routed to port A2 (B2). In model MB the reverse flow passes through a check valve. The MC type is identical to the MB type, but without the bypass check valve.

Model MP

In model MP, the pressure is reduced from port P2 to port P1.

All models support the connection of a pressure gauge to port M (thread G 1/4).

Technical Data

| Valve size / Cartridge cavity | | Size 06 / QF3 |
|---|-------------|---|
| Max. flow | l/min (GPM) | 40 (10.6) |
| Max. control flow | l/min (GPM) | 0.25 (0.07) |
| Max. operating pressure (ports P, A, B) | bar (PSI) | 320 (4600) |
| Max. operating pressure (port T) | bar (PSI) | 160 (2320) |
| Fluid temperature range (NBR) | °C (°F) | -30 ... +100 (-22 ... 212) |
| Fluid temperature range (FPM) | °C (°F) | -20 ... +120 (-4 ... 248) |
| Weight - models MA, MB | kg (lbs) | 1.20 (2.65) |
| - models MC, MP | | 1.10 (2.43) |
| - model RA1 | | 1.10 (2.43) |
| | Datasheet | Type |
| General information | HA 0060 | Products and operating conditions |
| Mounting interface | HA 0019 | ISO 4401-03-02-0-05 DIN 24340 (CETOP 03) |
| Spare parts | HA 8010 | |

ISO 4401-03-02-0-05

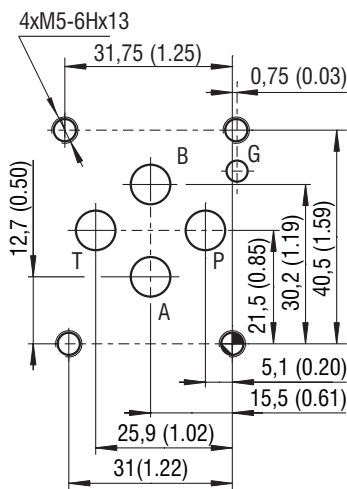

Ports P, A, B, T - max. Ø 7.5 mm (0.29 in)



The volume flow, which is needed for control of output pressure and maintaining the adjusted value of reducing pressure, flows permanently through the pilot stage of valve.

Characteristics measured at v = 32 mm²/s (156 SUS)

Reducing - relieving pressure related to flow rate

Relieving function A-T / Reducing function P-A

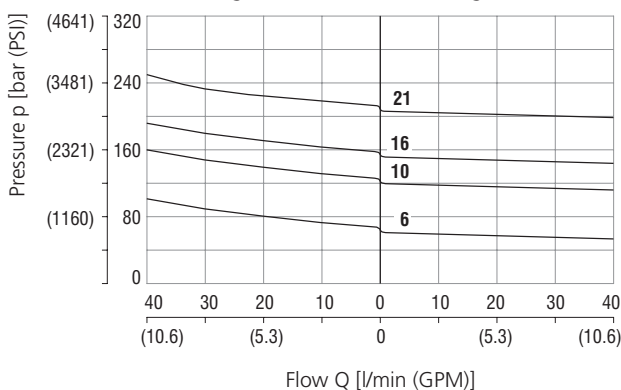

Pressure drop related to flow rate

Flow direction P-A Fully open valve through section

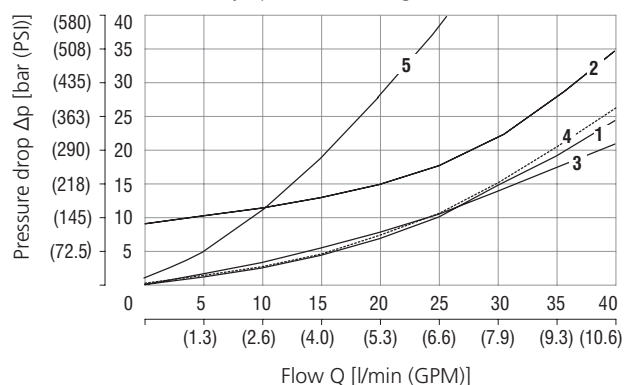

| Flow direction | 1 | 2 | 3 | 4 | 5 |
|----------------|----------------|----------------------|---|-------|--|
| | A1-A2 B1-B2 | A2-T B2-T P1-T | A2-A1 B2-B1 flow through check valve and fully opened main spool | P2-P1 | A2-A1 B2-B1 flow through check valve only |

Dimensions in millimeters (inches)

Model MA

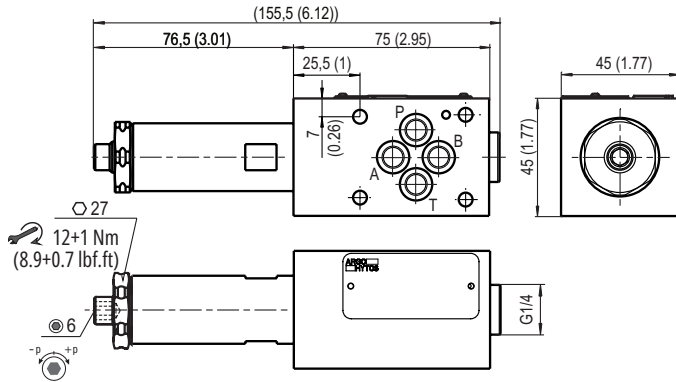

Models MB, MC

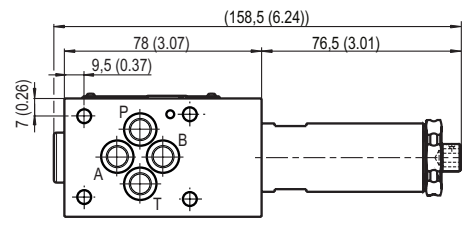

| Dimensions in mm (in) | | | | |
|-----------------------|-----------|---|---|-----------|
| Port | A | P | T | M |
| Thread | G 3/8 | | | G 1/4 |
| Depth of thread | 12 (0.47) | | | 12 (0.47) |
| Counterbore | Ø23 | | | Ø20 |
| Depth of counterbore | 1 | 1 | 1 | 1 |

Model MP

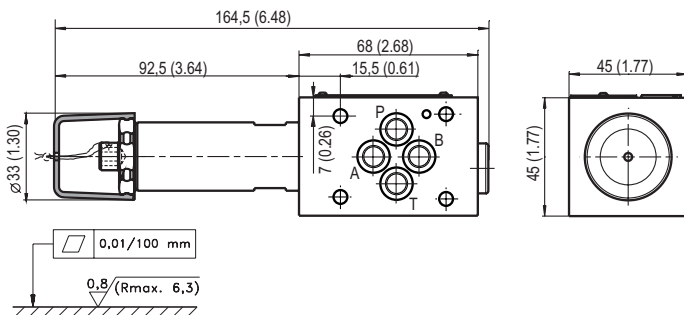

Required surface quality of the counterpart

Model RA1

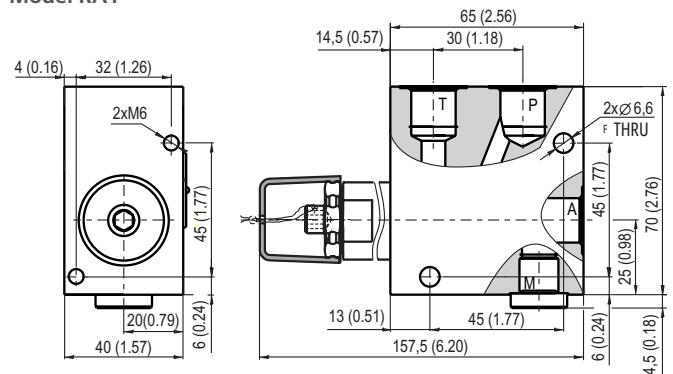

Functional Symbols

VRN2-06/MA

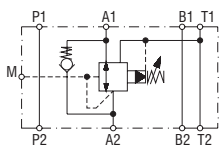

VRN2-06/MB

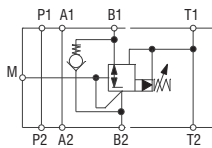

VRN2-06/MC

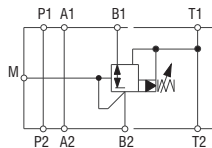

VRN2-06/MP

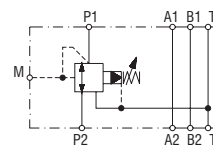

VRN2-06/RA1

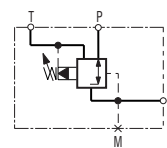

① valve side

② subplate or manifold side

Notice: The orientation of the symbol on the name plate corresponds with the valve function.

Ordering Code

VRN2-06/ - -

Pressure reducing - relieving valve, spool type, pilot operated, modular

Valve size
ISO 4401-03-02-0-05, DIN 24340 (CETOP 03), size 06

Model **Pressure reduction**
modular valve, on port A2 (with by-pass check valve) **MA**
modular valve, on port B2 (with by-pass check valve) **MB**
modular valve, on port B2 (without by-pass check valve) **MC**
modular valve, on port P1 **MP**
in-line valve, three ports, thread G 3/8 (P, T, A) **RA1**

Adjustable range of reduced pressure

| | |
|-----------------------------------|-----------|
| 10 ... 63 bar (145 ... 910 PSI) | 6 |
| 10 ... 100 bar (145 ... 1450 PSI) | 10 |
| 10 ... 160 bar (145 ... 2320 PSI) | 16 |
| 10 ... 210 bar (145 ... 3045 PSI) | 21 |

Surface treatment
No designation standard
A zinc-coated (ZnCr-3), ISO 9227 (240 h)
B zinc-coated (ZnNi), ISO 9227 (520 h)

Seals
No designation NBR
V FPM (Viton)

Adjustment option*
S allen key (hex. 6), without protective cap
RS hand screw, metal
RP hand screw, plastic
L allen key (hex. 6), with protective cap, sealable (lockwire holes)

*for dimensions of adjustment options see datasheet No.5153

VRN2-10/M(R)

Size 10 (D05) • Q_{max} 150 l/min (40 GPM) • p_{max} 320 bar (4600 PSI)

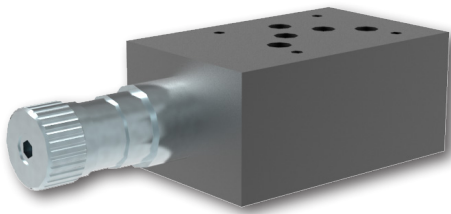

Technical Features

- › Pressure reducing - relieving valve, spool type, pilot operated with mounting interface acc. to ISO 4401, DIN 24340 (CETOP 05) or in-line design
- › Excellent stability throughout flow range with rapid response to dynamic pressure changes
- › Low hysteresis, accurate pressure control and low pressure drop
- › Reverse relief protectionw
- › Wide pressure range up to 320 bar
- › High flow capacity
- › Hardened precision parts
- › Adjustable by allen key or hand screw, optionally sealable (lockwire holes)
- › In the standard version, the valve housing is phosphated for basic surface corrosion protection and as preparation for painting. Steel parts are zinc-coated for 240 h salt spray protection acc. to ISO 9227
- › Enhanced surface protection for mobile sector available for the valve housing and steel parts (ISO 9227, 520 h salt spray)

ISO 4401-05-04-0-05

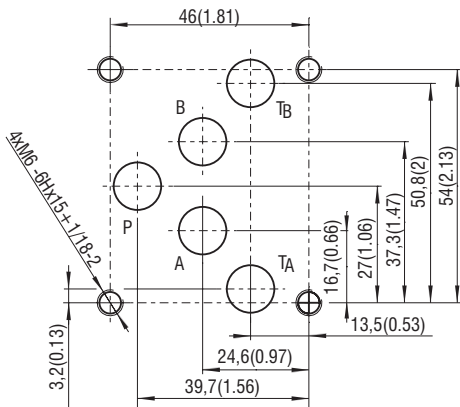

Ports P, A, B, T - max. \varnothing 11.2 mm (0.44 in)

Functional Description

This pilot operated pressure reducing valve is designed to reduce the system pressure at the consumer port. Its 3 way design provides reverse relief protection of the secondary circuit to the tank port. The pressure can be set by an adjustment screw and the valve is optionally equipped with lockwire holes for sealing. Valve bodies for vertical stacking assemblies are available with pressure reduction in ports A and P. Check valves incorporated into the valve bodies MA(B) enable the reverse flow to pass through the valve.

Model MA, MB

In models MA and MB, the flow enters the valve through port A1 (B1). The input pressure is reduced and routed to port A2 (B2). In model MB the reverse flow passes through a check valve.

Model MP

In model MP, the pressure is reduced from port P2 to port P1.

All models support the connection of a pressure gauge to port M (thread G 1/4).

Technical Data

| Valve size / Cartridge cavity | | Size 10 / K3 |
|---|-------------|---|
| Max. flow | l/min (GPM) | 150 (40) |
| Max. control flow | l/min (GPM) | 0.65 (0.17) |
| Max. operating pressure (ports P, A, B) | bar (PSI) | 320 (4600) |
| Max. operating pressure (port T) | bar (PSI) | 160 (2320) |
| Fluid temperature range (NBR) | °C (°F) | -30 ... +100 (-22 ... 212) |
| Fluid temperature range (FPM) | °C (°F) | -20 ... +120 (-4 ... 248) |
| Weight - models MA, MB | kg (lbs) | 3.20 (7.05) |
| - model MP | | 2.85 (6.28) |
| - model RA1 | | 2.20 (4.85) |
| | Datasheet | Type |
| General information | HA 0060 | Products and operating conditions |
| Mounting interface | HA 0019 | ISO 4401-05-04-0-05 DIN 24340 (CETOP 05) |
| Spare parts | HA 8010 | |



The volume flow, which is needed for control of output pressure and maintaining the adjusted value of reducing pressure, flows permanently through the pilot stage of valve.

Characteristics measured at $v = 32 \text{ mm}^2/\text{s}$ (156 SUS)

Reducing - relieving pressure related to flow rate

Relieving function A-T / Reducing function P-A

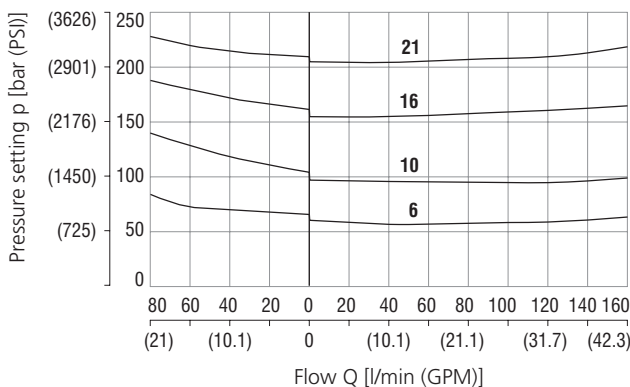

Pressure drop related to flow rate

Flow direction P-A Fully open valve through section

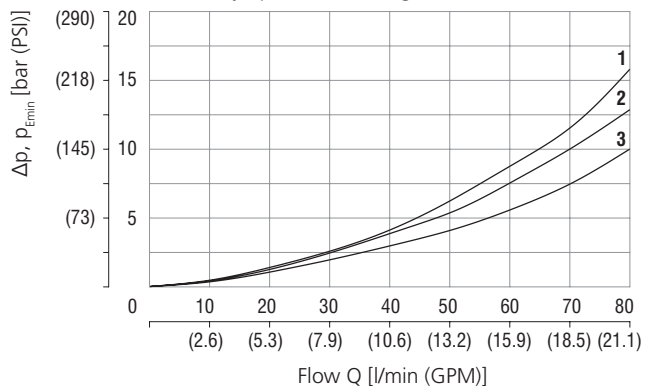

| | Models | Directions |
|---|--------|--------------|
| 1 | MA, MB | A-B, B1-B2 |
| 2 | MP | P2-P1 |
| 3 | MA, MB | A2-A1, B2-B1 |

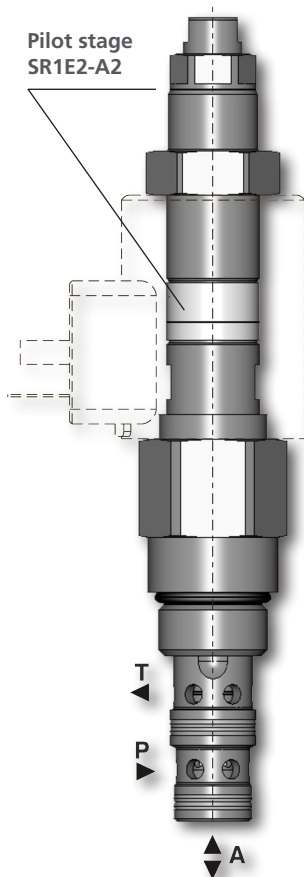

Symbol

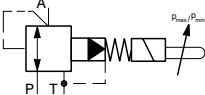

The volume flow, which is needed for control of output pressure and maintaining the adjusted value of reducing pressure, flows permanently through the pilot stage of valve.

Technical Features

- › Screw-in cartridge pilot operated valve with combined function of pressure reducing and relief valve
- › Solenoid operated remote switching between minimum and maximum set pressure
- › Possible combined function of pressure reducing and unloading valve
- › Five pressure ranges with a maximum settable pressure of 350 bar
- › Excellent stability throughout the flow range to 60 l/min
- › Accurate pressure control
- › Easily interchangeable solenoid coil and easy connector positioning
- › In the standard version, the valve is zinc-coated for 240 h protection acc. to ISO 9227. Enhanced surface protection for mobile sector available for the steel parts (ISO 9227, 520 h salt spray)

Functional Description

Screw-in cartridge pressure valve, pilot operated, combines function of reducing and relief valve. The valve continuously controls a pressure in A-port (connected to actuator) maintains the set pressure constant. When the A-line is overloaded by external load, A-port is connected to T-port and thanks to back flow to the tank the A-line is unloaded and protected (relief function). Additionally, it is possible to mechanically adjust two pressure values in A-port with adjusting screws built into the end plug of the solenoid actuating system. The two set pressure values can be remotely switched by solenoid. When the solenoid is switched on the valve is set to maximum pressure. The maximum adjustable pressure is defined by pressure range of valve. The minimum circuit pressure can be set from 6 bar to the set maximum pressure. The valve can be used in two ways – as a switcher between two set pressure values or as a combined reducing – unloading valve when one pressure value is adjusted on min. system pressure. The complete valve consists of poppet pilot valve, main spool valve with connected thread 7/8-14 UNF and a control solenoid with adjusting screws.

Technical Data

| | | |
|--|------------------|-----------------------------------|
| Valve size / Cartridge cavity | | 7/8-14 UNF-2A / B3 (C-10-3) |
| Max. flow | l/min (GPM) | 60 (15.9) |
| Max. operating pressure | bar (PSI) | 350 (5100) |
| Max. pressure (port T) | bar (PSI) | 100 (1450) |
| Min. adjustable pressure | bar (PSI) | 6 (87) |
| Fluid temperature range (NBR) | °C (°F) | -30 ... +80 (-22 ... 176) |
| Fluid temperature range (FPM) | °C (°F) | -20 ... +80 (-4 ... 176) |
| Ambient temperature range (NBR) | °C (°F) | -30 ... +50 (-22 ... 122) |
| Ambient temperature range (FPM) | °C (°F) | -20 ... +50 (-4 ... 122) |
| Supply voltage tolerance | % | AC, DC ± 10 |
| Max. switching frequency | 1/h | 5 000 |
| Weight | kg (lbs) | 0.6 (1.32) |
| Mounting position: If possible, the valve should be mounted with the coil vertically downward. | | |
| | | Datasheet |
| General information | | Type |
| Coil types | | Products and operating conditions |
| Valve bodies | In-line mounted | HA 0018 |
| | Sandwich mounted | HA 0028 |
| Cavity details / Form tools | | HA 0019 |
| Spare parts | | HA 8010 |

Characteristics measured at $v = 32 \text{ mm}^2/\text{s}$ (156 SUS)

Reducing - relieving pressure related to flow rate

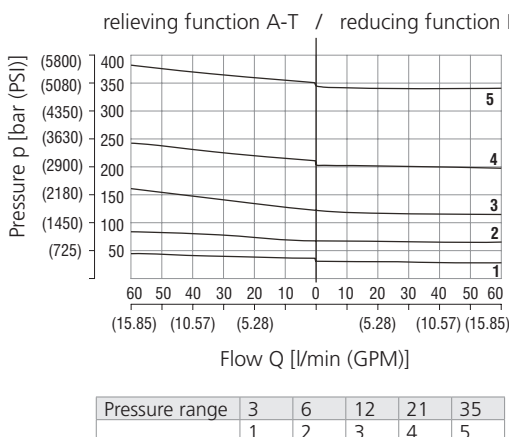

Example showing the adjustable pressures p_1 and p_2 ($p_1 \geq p_2$)

p_1 (p_{max} , relief pressure) is set as the higher working pressure (solenoid energized)
 p_2 (p_{min} , vented pressure) is set as a lower working pressure (solenoid de-energized)

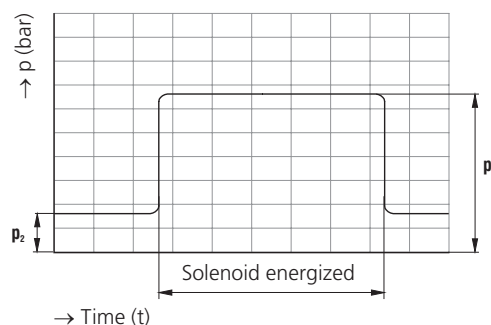

Characteristics measured at $v = 32 \text{ mm}^2/\text{s}$ (156 SUS)

Application example

Pressure drop related to flow rate

0 % of control current, A-T direction

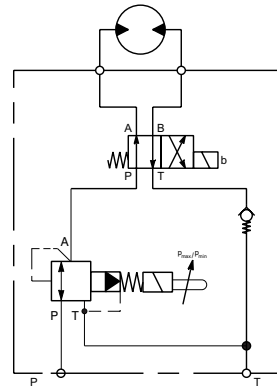
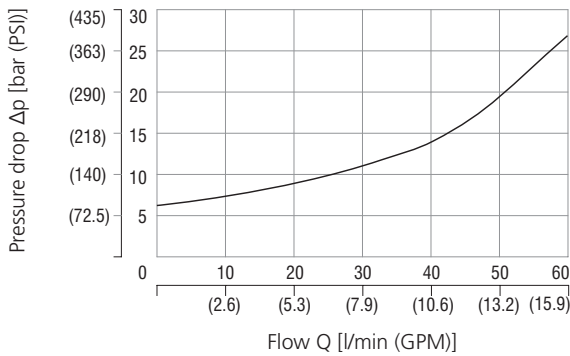

The valve is used to switch between two different set pressure values and to protect the applicator against pressure overloading. When p_2 is set on min. pressure, the pump and applicator are unloaded to the tank with a very low pressure drop. This results in less heating of the oil and therefore lower energy costs for the user.

The pressure p_1 (p_{max}) must be set before the pressure p_2 (p_{min}). To set p_1 , the solenoid is energized and the pressure adjusted with a flat wrench (size 10). The solenoid is then de-energized and the lower pressure adjusted with an allen key (hex. 3).

Dimensions in millimeters (in)

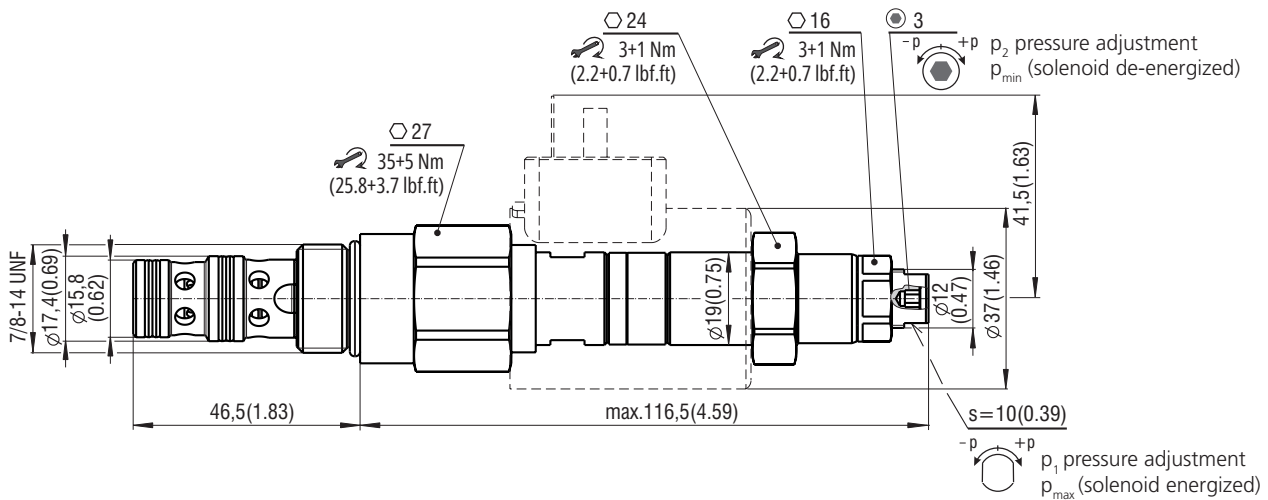

Ordering Code

SP4E1 - B3 / H [] [] - []

Pressure reducing-relieving solenoid-operated On/Off valve, piloted

Valve cavity
7/8-14 UNF (C-10-3)

Model
High performance

Max. reduced pressure

| | |
|--------------------------|----|
| up to 30 bar (440 PSI) | 3 |
| up to 60 bar (870 PSI) | 6 |
| up to 120 bar (1740 PSI) | 12 |
| up to 210 bar (3050 PSI) | 21 |
| up to 350 bar (5080 PSI) | 35 |

Surface treatment

- A zinc-coated (ZnCr-3), ISO 9227 (240 h)
- B zinc-coated (ZnNi), ISO 9227 (520 h)

No designation
V

Seals
NBR
FPM (Viton)