

Technical Information

# Joysticks

## PVRES and PVREL



**Revision history**

*Table of revisions*

<b>Date</b>	<b>Changed</b>	<b>Rev</b>
October 2015	Minor edits	0202
April 2015	Converted to Danfoss layout	BA
December 2010	Drawings	AD
September 2010	New back page	AC
May 2010	Japan location	AB
Mar 2003	First edition	AA

## Contents

### **PVRES joystick**

PVRES product image.....	4
General.....	4
Two proportional functions.....	4
Flow adjustment.....	4
On-off function.....	4
Characteristic.....	5
Electrical system.....	6
Two proportional functions.....	6
On-off-on function.....	7
Technical data.....	8
Code numbers, dimensions, and weight.....	8
Dimensions.....	9
Dimensions.....	10

### **PVRES accessories**

PVRES accessories image.....	11
General.....	11
Emergency stop module.....	11
Lamp module.....	11
Spacing and mounting modules.....	11
Panel mounting rings.....	11
PG 11 Screwed Cable Entry.....	12
Code numbers, dimensions, and weight.....	12
Dimensions.....	12
PVRES panel mounting plate .....	13

### **PVREL joystick**

PVREL product image.....	14
General.....	14
Proportional function.....	14
Variants.....	14
Standard .....	14
Hold function.....	14
Neutral lock.....	15
Float position.....	15
Installation.....	15
Characteristic.....	15
Signal (Us) as a function of the lever angle.....	15
Float positon.....	16
Electrical system.....	17
One proportional function.....	17
Technical data.....	18
Code numbers and weight.....	18
Accessories code number and weight.....	19
Dimensions.....	19

**PVRES joystick**

**PVRES product image**



**General**

PVRES can be used individually or with PVRES accessories built together to form a complete operating panel. PVRES is particularly suited to panel mounting and characterized by:

- finger-tip control
- small dimensions
- low weight
- built-in flow regulation
- accessories such as emergency stop and lamps (see [PVRES accessories](#) on page 11)

**Two proportional functions**

PVRES is supplied with one or two potentiometers. It is thus possible to regulate one function, or two functions at the same time.

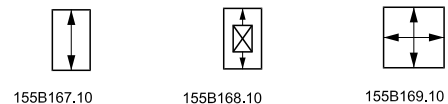

**Flow adjustment**

Two further adjustments per function are built into PVRES. Independently of each other, these limit the signal voltage (U<sub>S</sub>) and thereby the flow from proportional valve ports A and B without the movement of the remote control lever being limited. The oil flow can be infinitely reduced down to 25% of maximum flow.

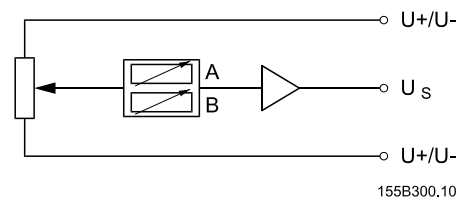

**On-off function**

Instead of the proportional functions, PVRES can be supplied with built-in switches. The contact functions can be either normally "ON" or normally "OFF" in neutral position.

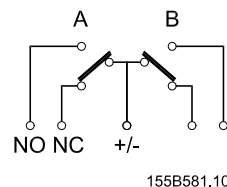

**PVRES joystick**

**Characteristic**

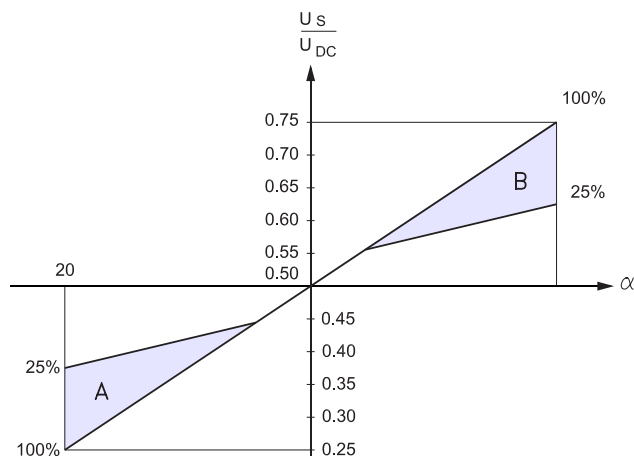

2 way	5.7 N [1.28 lbf]	1.7N [0.38 lbf]	1.7N [0.38 lbf]	5.7 N [1.28 lbf]
4 way	6.9 N [1.55 lbf]			6.9 N [1.55 lbf]

155B170.11

**PVRES joystick**

**Electrical system**

**Two proportional functions**

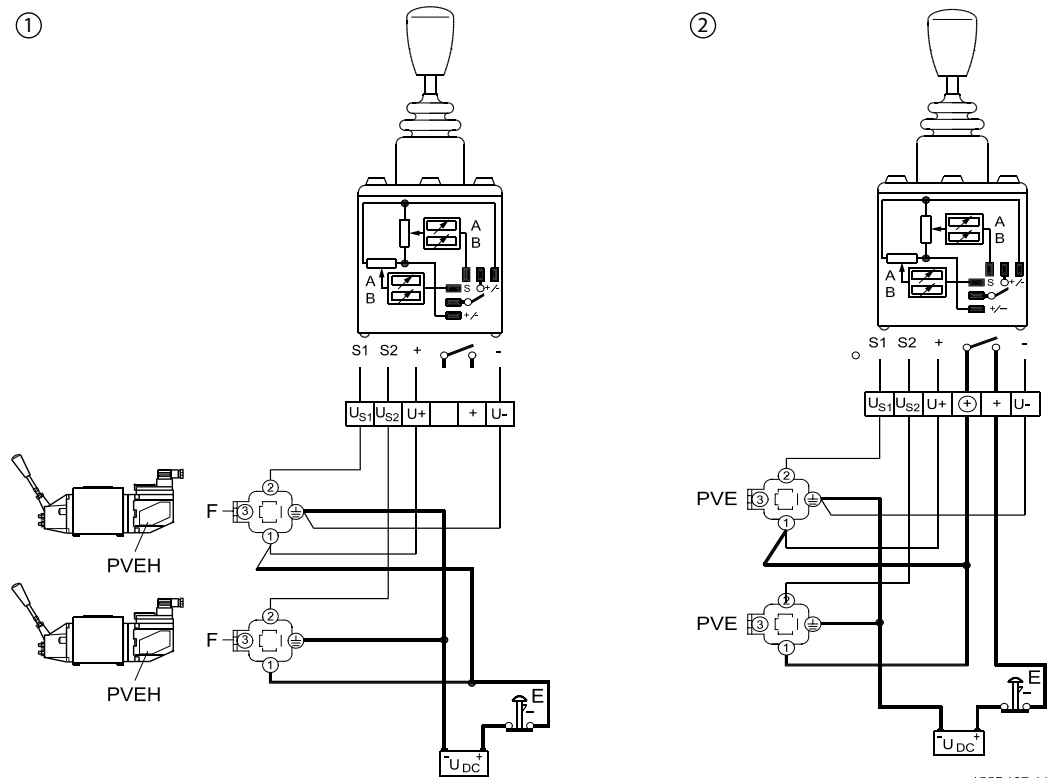

155B467.11

- 1. Two proportional functions **without** using neutral position switch
  - 2. Two proportional functions **with** the use of neutral position switch
- Fine line** Signal leads  
**Thick line** Supply leads  
**E** Emergency stop: An emergency stop should be built into all electrical systems  
**F** Lead from fault monitoring

**PVRES joystick**

**On-off-on function**

③

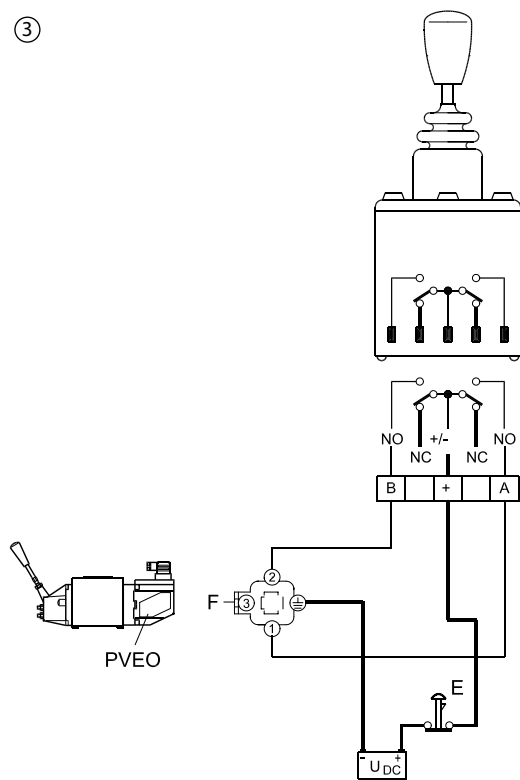

155B468.11

- 3.** On-off-on function
- Fine line** Signal leads
- Thick line** Supply leads
- E** Emergency stop: An emergency stop should be built into all electrical systems





**PVRES joystick**

**Technical data**

Supply voltage	$U_{DC}$	11- 30 $U_{DC}$
	Max. ripple	5%
Current consumption		< 80 mA
Max. force		50 N [11.24 lbf]
Output voltage (US)	$U_S$	0.25 → 0.75
	$U_{DC}$	
Neutral voltage (US)	$U_S$	0.5
	$U_{DC}$	
Output signal	Max. load	Two parallel connected PVEs
	Min. load impedance to $0,5 \cdot U_{DC}$	6 k $\Omega$
Signal current max.	$U_{DC} = 12\text{ V}$	$\pm 0.6\text{ mA}$ (resistive)
	$U_{DC} = 24\text{ V}$	$\pm 1.2\text{ mA}$
Neutral position switch max. current	$U_{DC} = 12\text{ V}$	2 A
	$U_{DC} = 24\text{ V}$	1 A
On - off - on switch max. current	$U_{DC} = 12\text{ V}$	0.7 A
	$U_{DC} = 24\text{ V}$	0.35 A
Ambient temperature		- 30 to + 60°C [-22 to 140°F]
Enclosure to IEC 529	Over mounting flange	IP 44
	Under mounting flange	IP 23

PVRE and PVRET must be connected to supply voltage at the same point as PVE.

**Code numbers, dimensions, and weight**

Function	Symbol	Version	Code number	Dimension mm [in]	Weight kg [lb]
1 Proportional	 155B167.10	Standard	155B4210	40 x 80 x 192 [1.57 x 3.15 x 7.56]	0.27 [0.60]
		Short	155B4218	40 x 80 x 135 [1.57 x 3.15 x 5.31]	0.24 [0.53]
1 Proportional	 155B168.10	Standard	155B4211	40 x 80 x 235 [1.57 x 3.15 x 9.25]	0.40 [0.88]
2 Proportional	 155B169.10	Standard	155B4212	80 x 80 x 192 [3.15 x 3.15 x 7.56]	0.38 [0.84]
		Short	155B4219	80 x 80 x 135 [3.15 x 3.15 x 5.31]	0.32 [0.70]
1 On-off-on	 155B367.10	Standard	155B4206	40 x 80 x 192 [1.57 x 3.15 x 7.56]	0.25 [0.55]



### PVRES joystick

#### Dimensions

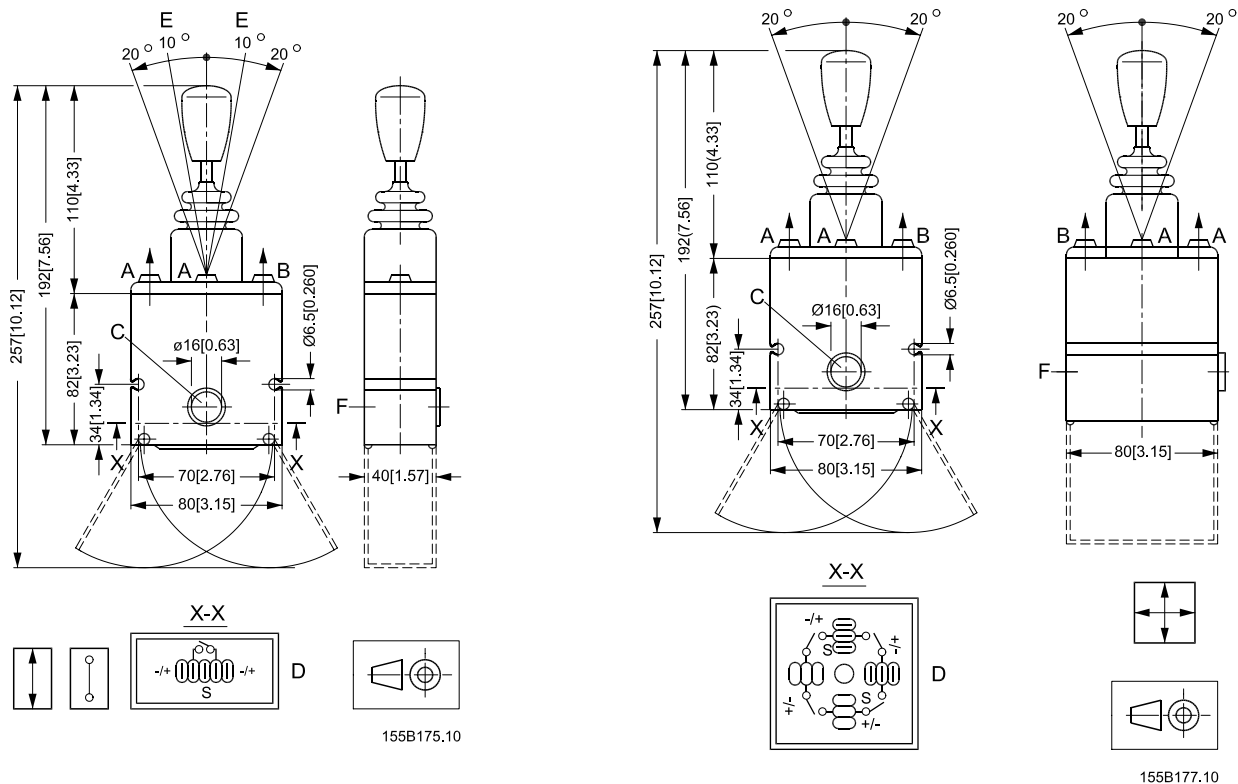

- A, B** Oil flow adjustment
- C** Deflection block
- D** Flat pin A 6.3 - 0.8
- E** Maximum travel for on-off-on version
- F**  $\varnothing 17$  hole for PG 11 screwed cable entry

**PVRES joystick**

**Dimensions**

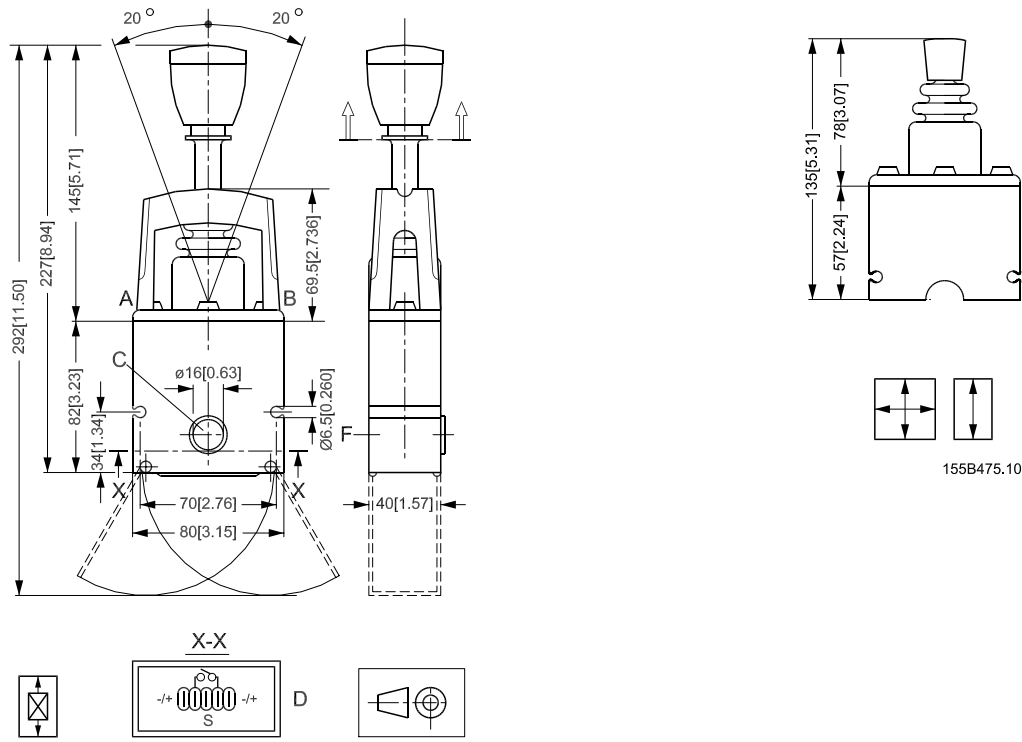

- A, B** Oil flow adjustment
- C** Deflection block
- D** Flat pin A 6.3 - 0.8
- E** Maximum travel for on-off-on version
- F**  $\varnothing 17$  hole for PG 11 screwed cable entry

## PVRES accessories

### PVRES accessories image

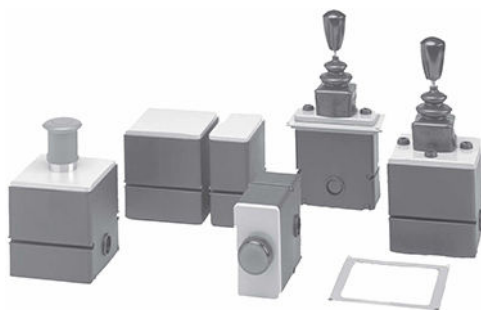

### General

PVRES accessories meet the demand for simple installation, monitoring and safety.

They also offer the possibility of mounting other components in connection with PVRES where uniform design is desirable.

### Emergency stop module

The module contains an emergency stop switch of the impact key type  $I_{NOM} = 10\text{ A}$



155B171.10

### Lamp module

The module contains a green lamp.  
 12 V and 24 V bulbs are included.



155B172.10

### Spacing and mounting modules

The modules are used between PVRES remote control units either as empty spacer modules or as mounting modules for switches, lamp indicators, starting keys, etc. The modules are available in widths 40 mm and 80 mm.



155B173.10



155B174.10

### Panel mounting rings

Panel mounting rings 40 mm and 80 mm are available for PVRES modules.

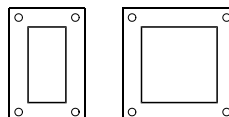

155B470.10

**PVRES accessories**

**PG 11 Screwed Cable Entry**

PG screwed cable entry and locknut, suitable for all PVRES modules.

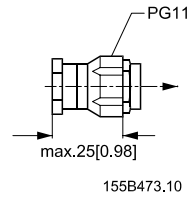

**Code numbers, dimensions, and weight**

Type	Symbol	Code number	Dimension mm [in]	Weight kg [lb]
Lamp module	 155B172.10	155B4213	40 x 80 [1.57 x 3.15]	0.22 [0.48]
Emergency stop	 155B171.10	155B4216	80 x 80 [3.15 x 3.15]	0.33 [0.73]
Spacer and mounting module	 155B173.10	155B4214	40 x 80 [1.57 x 3.15]	0.15 [0.33]
		155B4215	80 x 80 [3.15 x 3.15]	0.18 [0.40]
Top mounting plate with seal	 155B173.10	155B4876	60 x 100 [2.36 x 3.94]	0.04 [0.09]
		155B4877	100 x 100 [3.94 x 3.94]	0.05 [0.11]
PG 11 screwed cable entry		155B4875		0.01 [0.02]

**Dimensions**

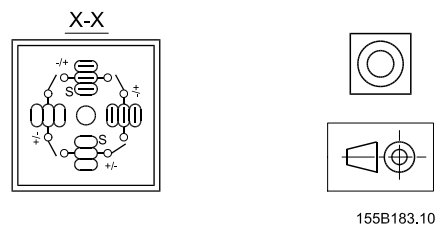
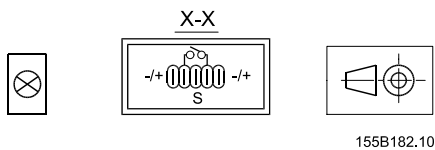
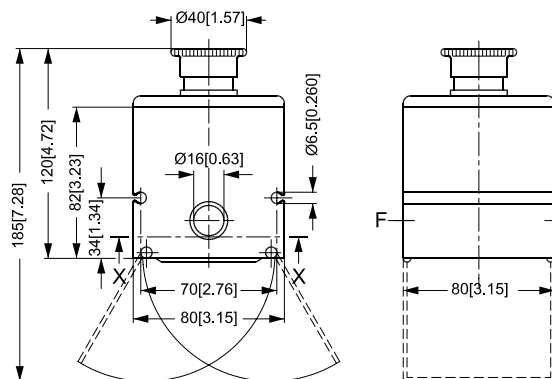
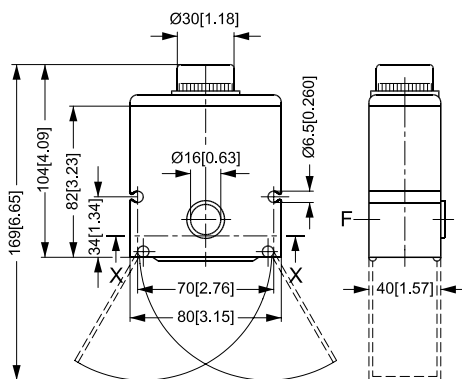

**PVRES accessories**

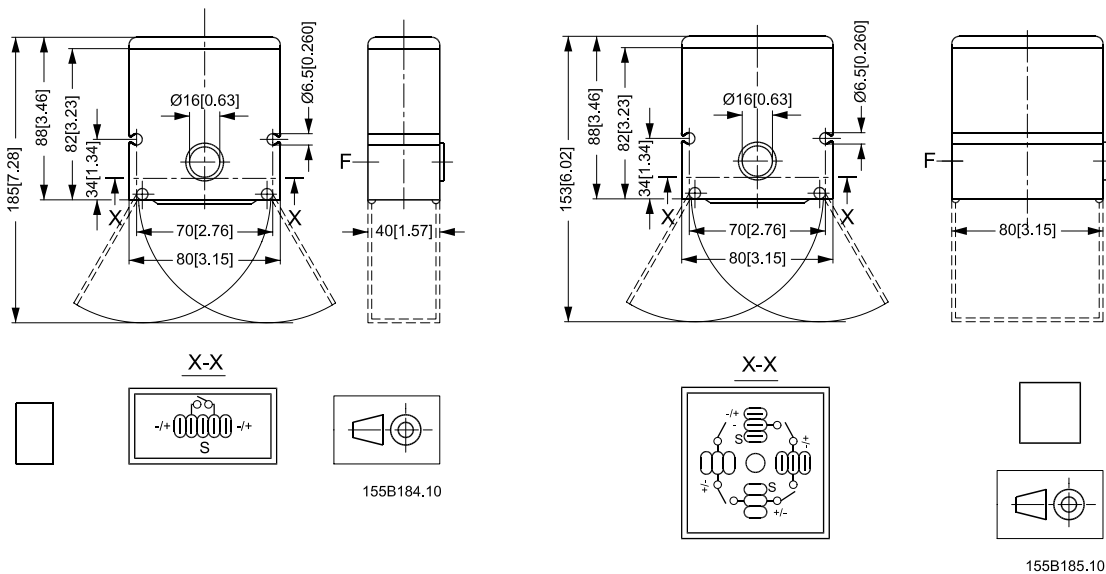

**PVRES panel mounting plate**

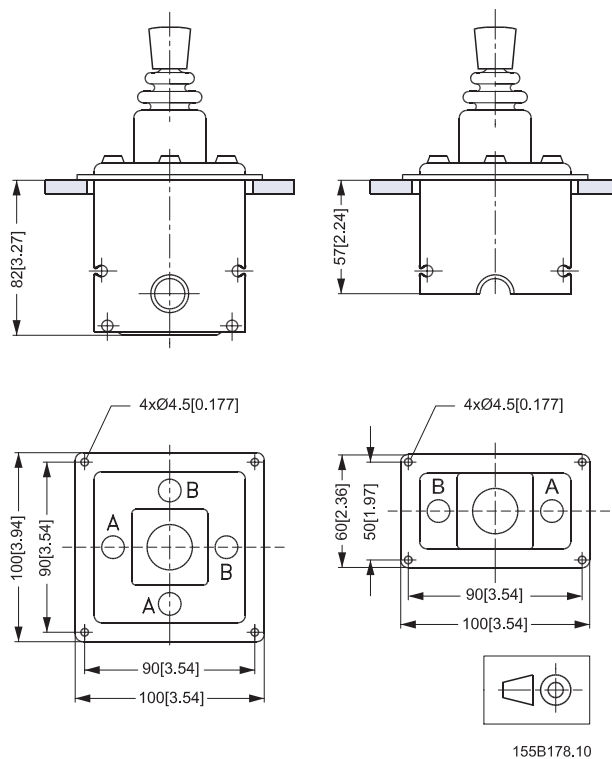

**PVREL joystick**

**PVREL product image**



**General**

PVREL is an electric remote control lever made in weather-resistant plastic.

PVREL is for easy mounting in operating panels.

PVREL is characterised by:

- IP 67 enclosure
- low operating forces
- robust construction
- small dimensions

**Proportional function**

The PVREL remote control levers contains a potentiometer for the control of one proportional function.

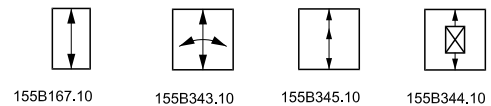

**Variants**

The PVREL series contains four variants. These can be ordered with or without neutral position switch.

**Standard**

Spring-centred remote control lever.  
 PVREL series basic model.

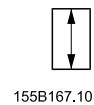

155B167.10

**Hold function**

Spring-centred with hold function. The remote control lever functions as the basic model, but by rotating the top of the handle the centre position can be displaced and a constant control signal is given. The remote control lever can still be activated from its set centre position as normal, but when released will return to its set centre point.

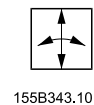

155B343.10

## PVREL joystick

### Neutral lock

Spring-centred with neutral position lock. The neutral position lock can be released by lifting the release ring under the handle. When the lever is returned to neutral position after manoeuvring, the neutral position lock will again engage.



155B344.10

### Float position

Spring-centred with float position control. The remote control lever normally has proportional regulation in both directions, but with mechanical limitation in one direction to 3/4 of the normal activation range. The final 1/4 is used for float position control. Access to the float position control is gained by lifting the release ring under the handle and moving the lever out to its float position. Here, on releasing the ring, the remote control lever becomes locked in float position. Return from float position is gained by again lifting the release ring and bringing the lever back to the proportional range.



155B345.10

### Installation

Correctly placed, the PVREL can comply with the grade of enclosure IP 67 above the mounting flange.

### Characteristic

#### Signal (Us) as a function of the lever angle

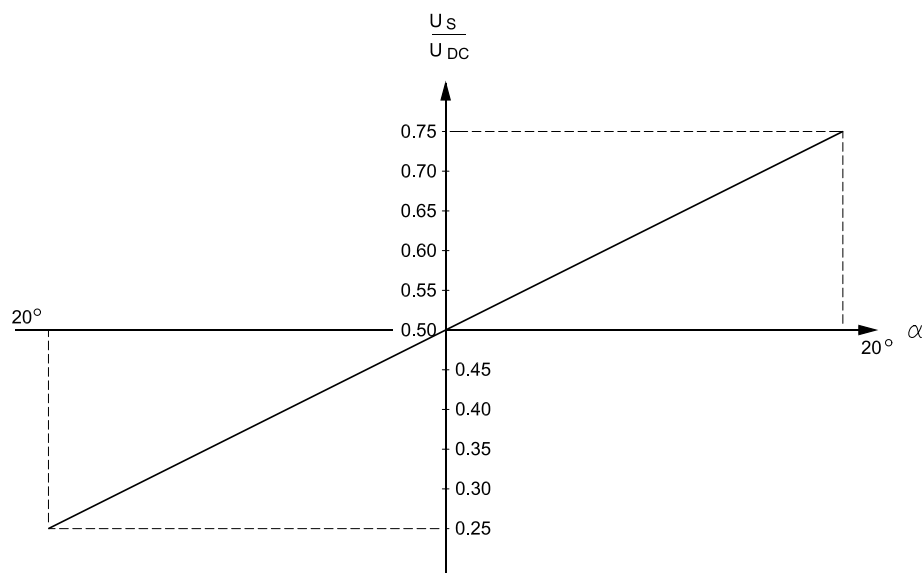

4.0 N [0.899 lbf]  
 7.7 N [1.731 lbf]\*

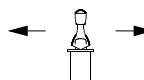

2.4 N [0.540 lbf]  
 3.4 N [0.764 lbf]\*



4.0 N [0.899 lbf]  
 7.7 N [1.731 lbf]\*

155B346.10

**PVREL joystick**

**Float position**

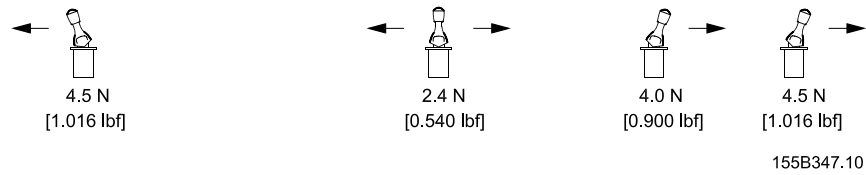
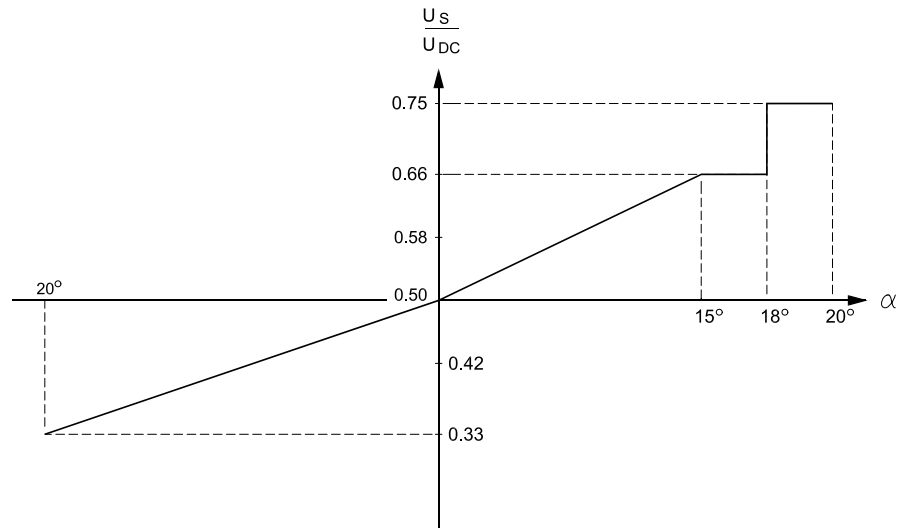



**PVREL joystick**

**Electrical system**

**One proportional function**

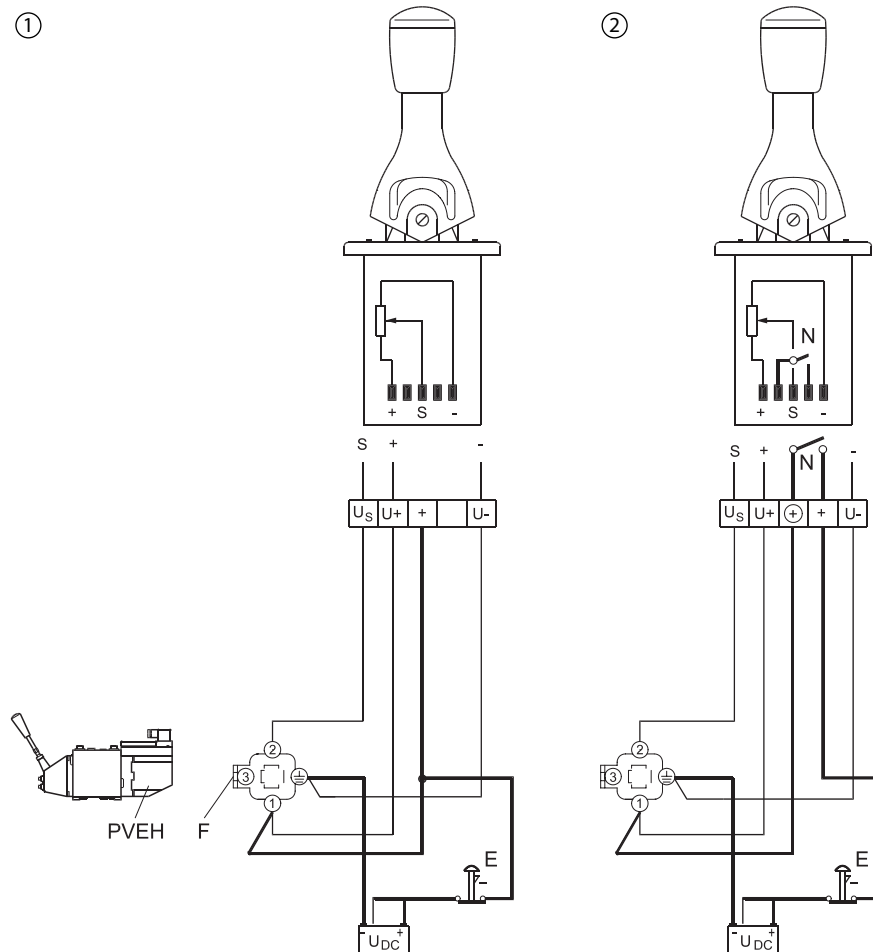

- 1. One proportional function **without** using neutral position switch
- 2. One proportional function **with** the use of neutral position switch
- Fine line** Signal leads
- Thick line** Supply leads
- E** Emergency stop: An emergency stop should be built into all electrical systems
- F** Lead from fault monitoring





## PVREL joystick

### Technical data

Supply voltage	$U_{DC}$	11- 30 $U_{DC}$
	Max. ripple	5%
Current consumption		< 80 mA
Max. force		100 N [22.5 lbf]
Output voltage (US)	$U_S$	0.25 → 0.75
	$U_{DC}$	
Neutral voltage (US)	$U_S$	0.5
	$U_{DC}$	
Output signal	Max. load	Two parallel connected PVEs
	Min. load impedance to $0,5 \cdot U_{DC}$	6 k $\Omega$
Signal current max.	$U_{DC} = 12\text{ V}$	$\pm 0.6\text{ mA}$
	$U_{DC} = 24\text{ V}$	$\pm 1.2\text{ mA}$
Neutral position switch max. current	$U_{DC} = 12\text{ V}$	2 A
	$U_{DC} = 24\text{ V}$	1 A
Ambient temperature		- 30 to + 60°C [-22 to 140°F]
Enclosure to IEC 529	Over mounting flange	IP 67
	Under mounting flange with bottom cover 155U2600	IP 65

PVREL must be connected to supply voltage at the same point as PVE.

### Code numbers and weight

Function	Symbol	Code number without neutral position switch	Code number with neutral position switch	Weight kg [lb]
Spring centered	 155B342.10	155U2601	155U2605	0.32 [0.70]
With detent	 155B343.10	155U2602	155U2606	0.32 [0.70]
With neutral position lock	 155B344.10	155U2603	155U2607	0.36 [0.79]
For float position	 155B345.10	155U2604	155U2608	0.36 [0.79]

For installation, all PVREL remote control levers are supplied with O-rings and bolt sets. The bottom cover is not included in the above mentioned code number.

**PVREL joystick**

**Accessories code number and weight**

Accessories	Code number	Weight kg [lb]
Bottom cover, including PG-screwed connections for IP 65 under the assembly flange	155U2600	0.025 [0.055]

**Dimensions**

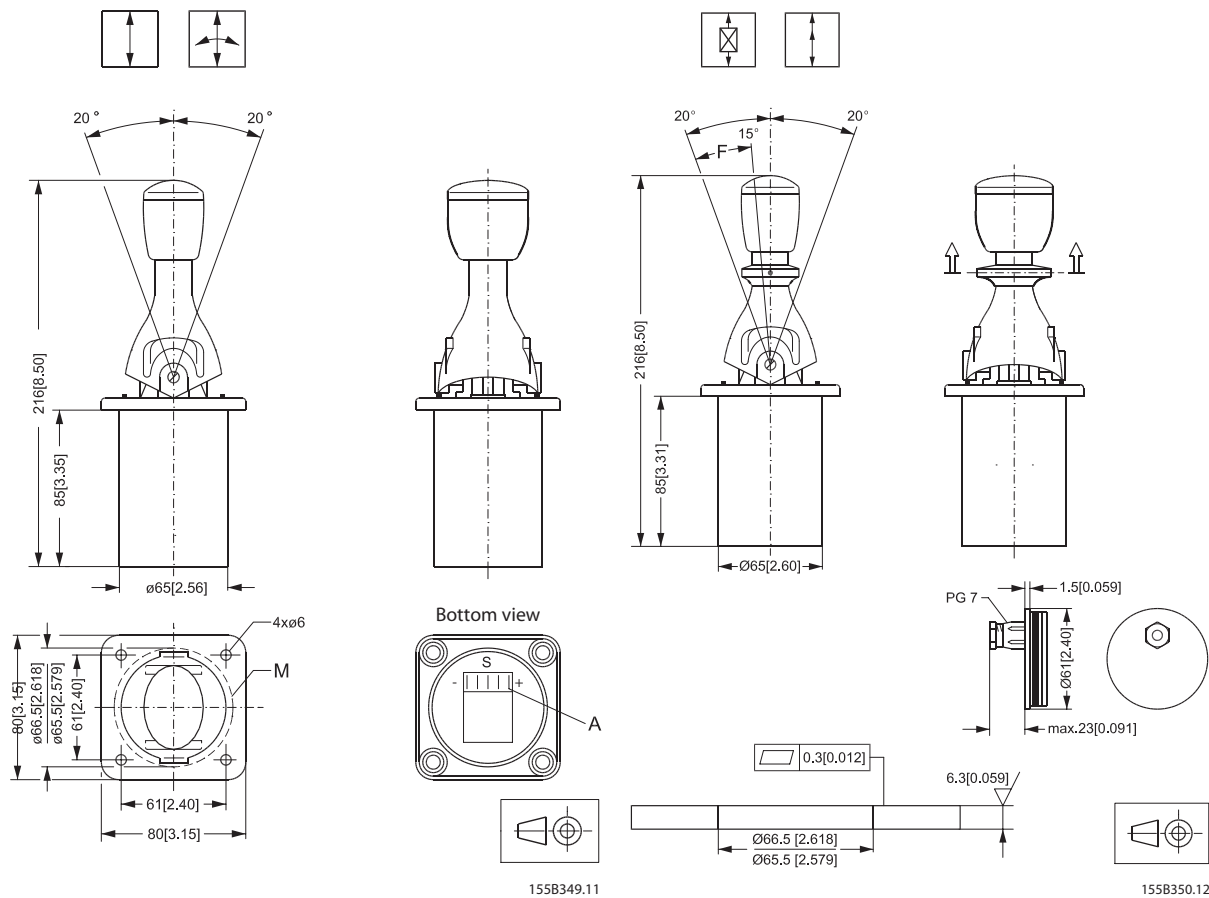

- F** Float position
- A** Socket A 6.3-0.8
- M** Assembly aperture







**Products we offer:**

- Bent Axis Motors
- Closed Circuit Axial Piston Pumps and Motors
- Displays
- Electrohydraulic Power Steering
- Electrohydraulics
- Hydraulic Power Steering
- Integrated Systems
- Joysticks and Control Handles
- Microcontrollers and Software
- Open Circuit Axial Piston Pumps
- Orbital Motors
- PLUS+1® GUIDE
- Proportional Valves
- Sensors
- Steering
- Transit Mixer Drives

**Danfoss Power Solutions** is a global manufacturer and supplier of high-quality hydraulic and electronic components. We specialize in providing state-of-the-art technology and solutions that excel in the harsh operating conditions of the mobile off-highway market. Building on our extensive applications expertise, we work closely with our customers to ensure exceptional performance for a broad range of off-highway vehicles.

We help OEMs around the world speed up system development, reduce costs and bring vehicles to market faster.

Danfoss – Your Strongest Partner in Mobile Hydraulics.

**Go to [www.powersolutions.danfoss.com](http://www.powersolutions.danfoss.com) for further product information.**

Wherever off-highway vehicles are at work, so is Danfoss. We offer expert worldwide support for our customers, ensuring the best possible solutions for outstanding performance. And with an extensive network of Global Service Partners, we also provide comprehensive global service for all of our components.

Please contact the Danfoss Power Solution representative nearest you.

**Comatrol**

[www.comatrol.com](http://www.comatrol.com)

**Schwarzmueller-Inverter**

[www.schwarzmueller-inverter.com](http://www.schwarzmueller-inverter.com)

**Turolla**

[www.turollaocg.com](http://www.turollaocg.com)

**Hydro-Gear**

[www.hydro-gear.com](http://www.hydro-gear.com)

**Daikin-Sauer-Danfoss**

[www.daikin-sauer-danfoss.com](http://www.daikin-sauer-danfoss.com)

Local address:

**Danfoss Power Solutions (US) Company**  
2800 East 13th Street  
Ames, IA 50010, USA  
Phone: +1 515 239 6000

**Danfoss Power Solutions GmbH & Co. OHG**  
Krokamp 35  
D-24539 Neumünster, Germany  
Phone: +49 4321 871 0

**Danfoss Power Solutions ApS**  
Nordborgvej 81  
DK-6430 Nordborg, Denmark  
Phone: +45 7488 2222

**Danfoss Power Solutions Trading (Shanghai) Co., Ltd.**  
Building #22, No. 1000 Jin Hai Rd  
Jin Qiao, Pudong New District  
Shanghai, China 201206  
Phone: +86 21 3418 5200

Danfoss can accept no responsibility for possible errors in catalogues, brochures and other printed material. Danfoss reserves the right to alter its products without notice. This also applies to products already on order provided that such alterations can be made without changes being necessary in specifications already agreed. All trademarks in this material are property of the respective companies. Danfoss and the Danfoss logotype are trademarks of Danfoss A/S. All rights reserved.