

Technical Information

PLUS+1[®] XM100 Autonomous Controller



Revision history

Table of revisions

Date	Changed	Rev
November 2021	Corrected feature data	0102
October 2021	First edition	0101

Contents

XM100 literature references

Technical Information (TI).....	4
Data Sheet (DS).....	4
PLUS+1® GUIDE User Manual.....	4
Latest version of technical literature.....	4

User liability and safety statements

OEM responsibility.....	5
Safety statements.....	5
Machine wiring guidelines.....	5
Machine welding guidelines.....	6

Overview

XM100 Autonomous Controller description.....	7
XM100 Features.....	7
PLUS+1® GUIDE.....	7
XM100 Related products part numbers.....	8
XM100 inputs and outputs.....	8
Input types.....	9
XM100 Technical Information.....	9

Input/output types and specifications

Digital/analog.....	10
Multifunction inputs.....	10
Audio outputs.....	12
Ethernet.....	12
Inertial measurement unit.....	12
CAN shield and analog input.....	13
Digital output.....	13
USB communication.....	14
RS232 communication.....	14
Sensor output.....	14

Product ratings

XM100 environmental testing criteria.....	15
Supply voltage/maximum current ratings.....	15

Installation

XM100 Autonomous Controller dimensions.....	16
---	----

Pin assignments C1—C9

XM100 pin information.....	18
----------------------------	----

XM100 literature references

Reference literature

Literature title	Literature type	Literature number
<i>XM100 Series PLUS+1®</i>	Technical Information	BC313277849405
<i>XM100 Series PLUS+1®</i>	Data Sheet	AI304864913574
<i>PLUS+1® GUIDE Software</i>	User Manual	AQ152886483724

Technical Information (TI)

A TI is comprehensive information for engineering and service personnel to reference.

Data Sheet (DS)

A DS is summarized information and parameters that are unique to a specific model.

PLUS+1® GUIDE User Manual

The Operation Manual (OM) details information regarding the PLUS+1® GUIDE tool used in building PLUS+1® applications. This OM covers the following broad topics:

- How to use the PLUS+1® GUIDE graphical application development tool to create machine applications
- How to configure module input and output parameters
- How to download PLUS+1® GUIDE applications to target PLUS+1® hardware modules
- How to upload and download tuning parameters
- How to use the PLUS+1® Service Tool

Latest version of technical literature

Comprehensive technical literature is online at www.danfoss.com

User liability and safety statements

OEM responsibility

The OEM of a machine or vehicle in which Danfoss products are installed has the full responsibility for all consequences that might occur. Danfoss has no responsibility for any consequences, direct or indirect, caused by failures or malfunctions.

- Danfoss has no responsibility for any accidents caused by incorrectly mounted or maintained equipment.
- Danfoss does not assume any responsibility for Danfoss products being incorrectly applied or the system being programmed in a manner that jeopardizes safety.
- All safety critical systems shall include an emergency stop to switch off the main supply voltage for the outputs of the electronic control system. All safety critical components shall be installed in such a way that the main supply voltage can be switched off at any time. The emergency stop must be easily accessible to the operator.

Safety statements

Warning

Unintended movement of the machine or mechanism may cause injury to the technician or bystanders. Improperly protected power input lines against over current conditions may cause damage to the hardware. Properly protect all power input lines against over-current conditions. To protect against unintended movement, secure the machine.

Warning

At high ambient temperatures the metal housing can become hotter than 70°C. Please use caution when touching the metal housing of the display



Caution

Unused pins on mating connectors may cause intermittent product performance or premature failure. Be sure to plug all pins on mating connectors.

Machine wiring guidelines

- Protect wires from mechanical abuse, run wires in flexible metal or plastic conduits.
- Use 85° C (185° F) wire with abrasion resistant insulation and 105° C (221° F) wire should be considered near hot surfaces.
- Use a wire size that is appropriate for the module connector.
- Separate high current wires such as solenoids, lights, alternators or fuel pumps from sensor and other noise-sensitive input wires.
- Run wires along the inside of, or close to, metal machine surfaces where possible, this simulates a shield which will minimize the effects of EMI/RFI radiation.
- Do not run wires near sharp metal corners, consider running wires through a grommet when rounding a corner.
- Do not run wires near hot machine members.
- Provide strain relief for all wires.
- Avoid running wires near moving or vibrating components.
- Avoid long, unsupported wire spans.
- Ground electronic modules to a dedicated conductor of sufficient size that is connected to the battery (-).

User liability and safety statements

- Power the sensors and valve drive circuits by their dedicated wired power sources and ground returns.
- Twist sensor lines about one turn every 10 cm (4 in).
- Use wire harness anchors that will allow wires to float with respect to the machine rather than rigid anchors.

Machine welding guidelines** Warning**

High voltage from power and signal cables may cause fire or electrical shock, and cause an explosion if flammable gasses or chemicals are present.

Disconnect all power and signal cables connected to the electronic component before performing any electrical welding on a machine.

The following is recommended when welding on a machine equipped with electronic components:

- Turn the engine off.
- Remove electronic components from the machine before any arc welding.
- Disconnect the negative battery cable from the battery.
- Do not use electrical components to ground the welder.
- Clamp the ground cable for the welder to the component that will be welded as close as possible to the weld.

Overview

XM100 Autonomous Controller description

Powerful Data Processing

The XM100 Autonomous Controller provides the high processing power required for state-of-the-art autonomous mobile machines. This controller is designed to meet the needs of autonomous machines by interfacing with GNSS, LiDAR, Radar and inertial sensors and performing autonomous navigation tasks. Ethernet and CAN connectivity allow the controller to manage complex tasks and command machine sub-systems, such as propel, steering and work function.

Product Highlights

The controller includes a powerful quad-core i.MX 6 platform with a Linux OS operating at 1.0 GHz. It has 8GB of flash and 2GB of DDR3 RAM to execute large, complex autonomous applications. This central processing unit delivers the power that will drive the future of your autonomous machine development.

Application Development

Users develop applications with PLUS+1® platform that enables novice programmers to quickly develop advanced applications. The PLUS+1® Autonomous Control Library is designed to work seamlessly with the vehicle control unit to enable autonomous machine functionality. PLUS+1® GUIDE is a Microsoft® Windows® based development environment and features a user-friendly, field proven, icon-based graphical programming tool, application downloader, and service/diagnostic tool.

XM100 Features

- Programmable with PLUS+1® GUIDE
- 2 x 12-pin DEUTSCH DTP connectors
- Processor: i.MX 6 QuadPlus, 1.0 GHZ
- 8 GB flash, 2 GB DDR3 RAM
- 4 CAN ports
- 4-wire Ethernet port (10/100)
- Audio out
- 2 RGB LEDs
- 6-Axis Inertial Measurement Unit
- GNSS Receiver position accuracy 1.5m CEP50
- 5 Vdc sensor supply output
- 9 to 36 Vdc power supply, monitored internally
- Wake over digital input

[Comprehensive technical literature is online at www.danfoss.com](http://www.danfoss.com)

PLUS+1® GUIDE

PLUS+1® GUIDE (Graphical User Integrated Development Environment) is a complete toolbox that generates downloadable applications for all programmable PLUS+1® Compliant products.

Caution

Unwanted system failure may occur.
Refer to PLUS+1® GUIDE Software User Manual, **AQ152886483724** for best programming practices.
<https://www.danfoss.com/en/products/software/dps/plus1-software/plus1-guide/#tab-overview>

Overview

XM100 Related products part numbers

Product part number

11283139	XM100 Autonomous Controller
-----------------	-----------------------------

Related products part numbers

Connector kit

10100944	DEUTSCH 12-pin Connector Kit (DTM06-12SA)
-----------------	---

Connection tools

10100744	DEUTSCH stamped contacts terminal crimp tool, size 20
10100745	DEUTSCH solid contacts terminal crimp tool

Cable kit

11231512	Cable, M12 4-pin to USB device (2m)
11130713	Cable, M12 8-Pin to Lead Wires (1.5m)
11130712	Cable, M12 5-Pin to Lead Wires (1.5m)

Antenna

11283266	External GNSS Antenna (5m)
-----------------	----------------------------

Software

11179523 (renew annually with 11179524 to keep software updates)	PLUS+1® GUIDE Professional Software (includes 1 year of software updates, a single user license, Service and Diagnostic tool and Screen Editor)
70405444	PLUS+1® Autonomous Control Library (ACL)

XM100 inputs and outputs

8 inputs

- 4 universal (DIN/AIN/FreqIn/Rheo/4-20 mA) that are user-defined as either:
 - Analog: with configurable ranges 0 to 5.25 Vdc (with over range protection) or 0 to 36 Vdc;
 - Digital: pull up (5 Vdc), pull down (0 Vdc), or pull to center (2.5 Vdc);
 - Frequency: (timing) 1 Hz to 10 kHz
 - Rheostat: (Resistance) from 0 to 1000 Ohm
 - Current: 4 to 20 mA
- 2 digital/analog (DIN/AIN) that are user-defined as either:
 - Analog: 0 to 5.25 Vdc or 0 to 36 Vdc
 - Digital: pull up (5 Vdc), pull down (0 Vdc), or pull to center (2.5 Vdc);
- Ignition Input (K15)
- Wake Input (DigIn)

Overview

5 outputs

- 4 digital (Sinking DOUT) 500 mA
- Sensor Supply (+5 Vdc)

Input types

Each PLUS+1® Module input pin supports one of the above functional types. For pins with multiple functions, input configurations are user programmable using PLUS+1® GUIDE templates.

When using inputs in digital mode, it is advised to use the software selectable pull-up or pull-down resistors.

XM100 Technical Information

Processor	i.MX6
Supply Voltage	9-36 Vdc
Connector	DEUTSCH DTM06-12SA
IP Rating	IP66 and IP67 front and back
Operating Temperature	-30°C to +70°C [-22°F to 158°F]
Storage Temperature	-40°C to +85°C [-40°F to 185°F]
Vibration/Shock	IEC 60068-2-64 (7.67g) /2-27 (50g)
EMI/RFI Rating	100 V/m
Humidity	IEC 60068-2-78, 60068-2-30
Transients	ISO 7637/1, 2, 3
Certifications	FCC, IC, RCM, RoHS

Input/output types and specifications

Digital/analog

Digital inputs

Description	Values			Unit	Notes
	Min.	Typ.	Max.		
General:					
Input voltage range	0		36	V	Maximum Voltage at pin.
Rising Threshold Voltage			3.91	V	
Falling Threshold Voltage	0.85			V	
Input Impedance	14.8	15	15.2	kΩ	

Digital / Analog

Description	Values			Unit	Notes
	Min.	Typ.	Max.		
Input voltage range	0		36	V	Maximum Voltage at pin.
Low level digital input				V	Level adjustable in software
High level digital input				V	Level adjustable in software Voltage $\geq V_{inhigh}$ Digital Input = True
Time to change state in response to step input		---		ms	Depends on application (OS.ExecTime)
Minimum discernable voltage			0.03	V	
Maximum discernable voltage	5.64	5.78	5.92	V	
Resolution		1.4		mV	
Worst case offset and gain error			± 0.14	V	@ $V_{Measure} = 5.78V$
Non-linearity			± 8.5	mV	
Input Impedance	230	233	236	kΩ	
This input can also be used as a CAN shield. It provides a 0.68uF capacitor to ground through a 1 ohm resistor.					

Multifunction inputs

Digital / Analog / Frequency / Rheostat / Current inputs

Description	Values			Unit.	Notes.
	Min.	Typ.	Max.		
General:					
Input voltage range	0		36	V	Maximum Voltage at pin
Frequency range	0		10,000	Hz	
Quad count or Phase shift	0		5,000	Hz	
Low level digital input				V	Level adjustable in software
High level digital input				V	Level adjustable in software Voltage $\geq V_{inhigh}$ Digital Input = True
Time to change state in response to step input		---		ms	Depends on application (OS.ExecTime)
Low Range:					
Minimum discernable voltage			13	mV	
Maximum discernable voltage	379	404	430	mV	

Input/output types and specifications

Digital / Analog / Frequency / Rheostat / Current inputs (continued)

Description	Values			Unit.	Notes.
	Min.	Typ.	Max.		
Resolution		0.1		mV	
Worst case offset and gain error			±0.6	mV	@ $V_{\text{Measure}} = 404\text{mV}$
Non-linearity			±26	mV	
Rising Voltage Threshold			314	mV	Voltage required for frequency input
Falling Voltage Threshold	55			mV	Voltage required for frequency input
Input Impedance	232	233	234	kΩ	No pull up or pull down
Input Impedance (5V/GND)	13.9	14.1	14.3	kΩ	Pull up or pull down
Input Impedance (2.5V)	7.1	7.3	7.4	kΩ	Pull up and pull down
Middle Range:					
Minimum discernable voltage			0.03	V	
Maximum discernable voltage	5.69	5.78	5.88	V	
Resolution		1.4		mV	
Worst case offset and gain error			±0.14	V	@ $V_{\text{Measure}} = 5.78\text{V}$
Non-linearity			±8.5	mV	
Rising Voltage Threshold			4.25	V	Voltage required for frequency input
Falling Voltage Threshold	0.97			V	Voltage required for frequency input
Input Impedance	232	233	234	kΩ	No pull up or pull down
Input Impedance (5V/GND)	13.9	14.1	14.3	kΩ	Pull up or pull down
Input Impedance (2.5V)	7.1	7.3	7.4	kΩ	Pull up and pull down
High Range:					
Minimum discernable voltage			0.16	V	
Maximum discernable voltage	37.9	38.8	39.7	V	
Resolution		9.5		mV	
Worst case offset and gain error			±0.95	V	@ $V_{\text{Measure}} = 38.8\text{V}$
Non-linearity			±56.8	mV	
Rising Voltage Threshold			28.71	V	Voltage required for frequency input
Falling Voltage Threshold	6.47			V	Voltage required for frequency input
Input Impedance	109.1	109.3	109.5	kΩ	No pull up or pull down ($V_{\text{in}} < 5.7\text{V}$)
Input Impedance (5V/GND)	13.0	13.2	13.4	kΩ	Pull up or pull down ($V_{\text{in}} < 5.7\text{V}$)
Input Impedance (2.5V)	6.9	7.0	7.1	kΩ	Pull up and pull down ($V_{\text{in}} < 5.7\text{V}$)
Input Impedance ($V_{\text{in}} > 5.7\text{V}$)					See chart below

Input/output types and specifications

Audio outputs

Audio outputs

Symbol	Description	Unit	Minimum	Typical	Maximum	Comment
	Output Power	mW		62.5		@1kHz

[Right and left channel included - Stereo output](#)

Ethernet

Ethernet

Symbol	Description	Unit	Minimum	Typical	Maximum	Comment
	Available Baud Rates	bps		10M 100M		10M is default
	Max Input Voltage Range	V	-25		25	Receiver Input

Inertial measurement unit

Inertial measurement unit

Description	Range		Accuracy percentage over full range
	Min.	Max.	
Accelerometer	±2g: 16384 LSB/g	±16 g:2048 LSB/g	±0.4%
Gyroscope	±125 dps: 262.1 LSB/dps	±2000 dps: 16.4 LSB/dps	±0.4% (with CRT)

[For a directional drawing, please see XM100 Autonomous Controller dimensions on page 16.](#)

Input/output types and specifications

CAN shield and analog input

CAN ports

Description	Unit	Minimum	Typical	Maximum	Comment
Available Baud Rates	kbps		50 100 125 250 500 1000		Default value
Max Input Voltage Range	V	-27		40	CAN HI & CAN LO

Digital output

500 mA Low-side DOUT (DOUT14)

Description	Unit	Minimum	Typical	Maximum	Comment
Output Voltage	V	0		V _{Battery}	I _{out} = 500mA
Output Current	mA	500			

Input/output types and specifications

USB communication

USB port

Description	Unit	Minimum	Typical	Maximum	Comment
Available Baud Rates	Mbps	12		480	USB 2.0 supported
Max Input Voltage Range	V	-0.3		7.3	
Vbus Voltage		4.4	5	5.25	
Vbus Current	mA			250	

RS232 communication

RS232 Port

Description	Unit	Minimum	Typical	Maximum	Comment
Available Baud Rates	bps	9600 11400 19200 28800 38400 57600 115200			19200 is default
Max Input Voltage Range	V	-25 -13.2		25 13.2	Receiver Input Transmitter Output

Sensor output

Sensor supply output 5V / 100mA

Description	Unit	Minimum	Typical	Maximum	Comment
Sensor Output Voltage	V	4.85	5	5.15	
Sensor Output Current	mA			100	

Product ratings

XM100 environmental testing criteria

Mechanical environment

Description	Applicable standard	Comment
Vibration	IEC 60068-2-64 test Fh	3.17g
Bump	IEC 60068-2-27 test Eb	
Shock	IEC 60068-2-27 test Ea	50g
Free fall	IEC 60068-2-31 test Ed	

Supply voltage/maximum current ratings

XM100 Autonomous Controllers are designed to operate with a nominal 9 to 36 Vdc power supply with reverse polarity protection.

Battery power input

Description	Unit	Minimum	Typical	Maximum	Comment
Operating temperature	°C	-30	—	+70	
Storage temperature	°C	-40	—	+85	

Installation

XM100 Autonomous Controller dimensions

Pin locations and controller dimensions

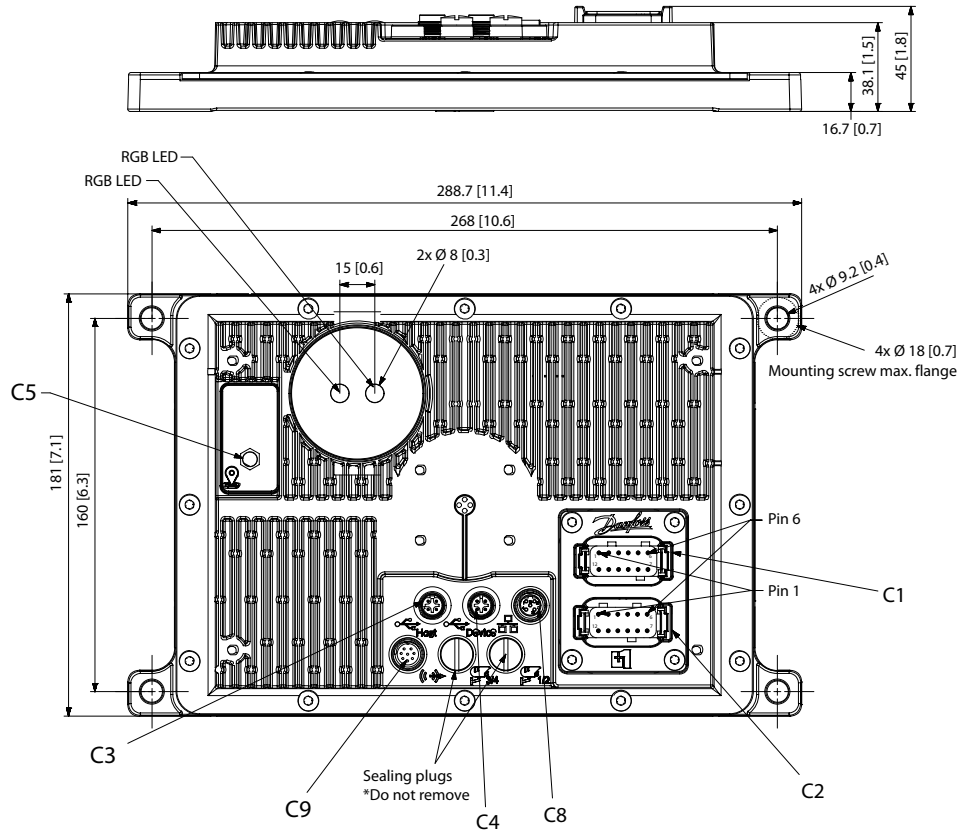

Installation

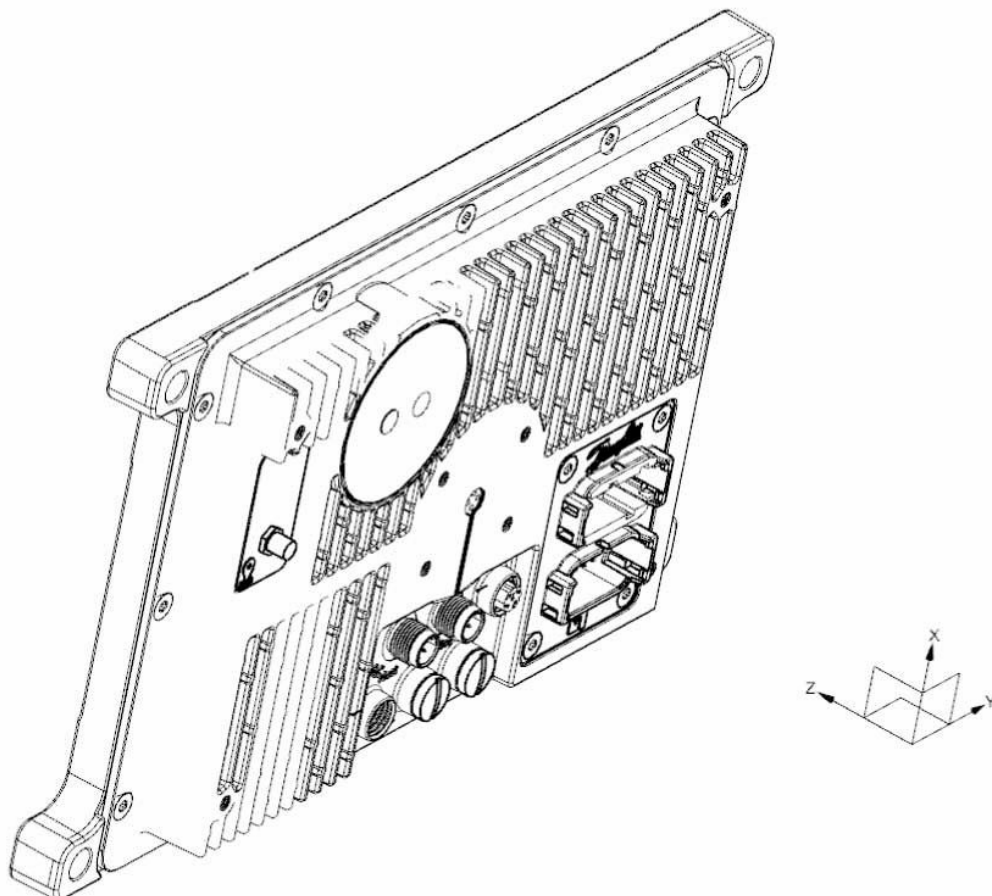

Pin assignments C1—C9

Connectors & mates

Connector Numbers	Description	Mate	Function	Rating	Max Wire Size
C1	Deutsch DTM04-12PA	Deutsch DT06-12SA	Main	7.5A	16 AWG
C2	Deutsch DTM04-12PB	Deutsch DT06-12SB	Main	7.5A	16 AWG
C3	Phoenix M12 1552214	Phoenix 1406130	USB Host		24 AWG
C4	Phoenix M12 1439939	Phoenix 1406189	USB Device		24 AWG
C5	Phoenix M12 1551451	Phoenix 1406131	Ethernet		24 AWG
C6	Phoenix M12 1551422	Phoenix 1406073	RS232 and Audio		24 AWG

XM100 pin information

C1 - DEUTSCH DTM06-12SA, 12 pin

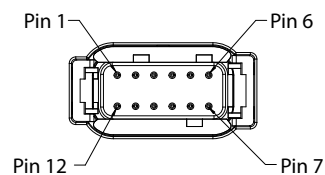

C1 pin	Function
1	Power ground -
2	Power supply +
3	CAN 0+
4	CAN 0-
5	Anin / CAN shield
6	CAN 1+
7	CAN 1-
8	Sensor supply out (+5 V)
9	K15 ignition input (digital input)
10	Multifunction input (Digin/Anin/Freq/4-20mA/Rheostat)
11	Multifunction input (Digin/Anin/Freq/4-20mA/Rheostat)
12	Digital out (0.5A sinking)

C2 - DEUTSCH DTM06-12SB, 12 pin, "B" key

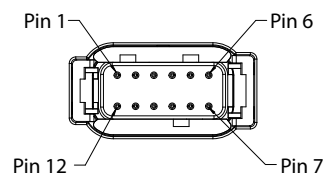

C2 pin	Function
1	Sensor ground
2	Digital out (0.5A sinking)
3	CAN 2+
4	CAN 2-
5	Anin / CAN shield
6	CAN 3+
7	CAN 3-

Pin assignments C1—C9

C2 pin	Function
8	Multifunction input (Digin/Anin/Freq/4-20mA/Rheostat)
9	Multifunction input (Digin/Anin/Freq/4-20mA/Rheostat)
10	Wake input (digital input)
11	Digital out (0.5A sinking)
12	Digital out (0.5A sinking)

C3 - M12 4 pin, USB device, "A" key



C3 Pin	Function
1	Device data +
2	Device data -
3	Device Vbus
4	Ground

C4 - M12 4 pin, USB host, "B" key



C4 Pin	Function
1	Host data +
2	Host data -
3	Host Vbus
4	Ground

C5 – GNSS antenna SMA coaxial



Antenna must be installed properly to the machine to avoid interference and to ensure the line of sight to the sky.

Pin	Function
Threads	Ground
Pin	Signal

C8 - M12 4 pin female, Ethernet, "A" key



Pin assignments C1—C9

C8 Pin	Function
1	TxD+
2	RxD+
3	TxD-
4	RxD-

C9 - M12 8 pin female, Stereo, "A" key



C9 Pin	Function
1	TxD
2	RxD
3	Ground
4	NC
5	Left channel
6	Right channel
7	Ground
8	NC

Products we offer:

- Cartridge valves
- DCV directional control valves
- Electric converters
- Electric machines
- Electric motors
- Gear motors
- Gear pumps
- Hydraulic integrated circuits (HICs)
- Hydrostatic motors
- Hydrostatic pumps
- Orbital motors
- PLUS+1® controllers
- PLUS+1® displays
- PLUS+1® joysticks and pedals
- PLUS+1® operator interfaces
- PLUS+1® sensors
- PLUS+1® software
- PLUS+1® software services, support and training
- Position controls and sensors
- PVG proportional valves
- Steering components and systems
- Telematics

Danfoss Power Solutions is a global manufacturer and supplier of high-quality hydraulic and electric components. We specialize in providing state-of-the-art technology and solutions that excel in the harsh operating conditions of the mobile off-highway market as well as the marine sector. Building on our extensive applications expertise, we work closely with you to ensure exceptional performance for a broad range of applications. We help you and other customers around the world speed up system development, reduce costs and bring vehicles and vessels to market faster.

Danfoss Power Solutions – your strongest partner in mobile hydraulics and mobile electrification.

Go to www.danfoss.com for further product information.

We offer you expert worldwide support for ensuring the best possible solutions for outstanding performance. And with an extensive network of Global Service Partners, we also provide you with comprehensive global service for all of our components.

Local address:

Hydro-Gear

www.hydro-gear.com

Daikin-Sauer-Danfoss

www.daikin-sauer-danfoss.com

**Danfoss
Power Solutions (US) Company**
2800 East 13th Street
Ames, IA 50010, USA
Phone: +1 515 239 6000

**Danfoss
Power Solutions GmbH & Co. OHG**
Krokamp 35
D-24539 Neumünster, Germany
Phone: +49 4321 871 0

**Danfoss
Power Solutions ApS**
Nordborgvej 81
DK-6430 Nordborg, Denmark
Phone: +45 7488 2222

**Danfoss
Power Solutions Trading
(Shanghai) Co., Ltd.**
Building #22, No. 1000 Jin Hai Rd
Jin Qiao, Pudong New District
Shanghai, China 201206
Phone: +86 21 2080 6201

Danfoss can accept no responsibility for possible errors in catalogues, brochures and other printed material. Danfoss reserves the right to alter its products without notice. This also applies to products already on order provided that such alterations can be made without subsequent changes being necessary in specifications already agreed. All trademarks in this material are property of the respective companies. Danfoss and the Danfoss logotype are trademarks of Danfoss A/S. All rights reserved.