

Locking Assemblies Bending Loads

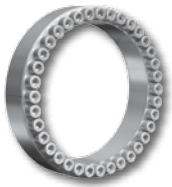

RfN 7012



RfN 7012.2



RfN 7015.0



RfN 7015.1



RfN 7515

EN 08.2019

Product Paper & Tech Paper



Welcome



Machine Building



Aerospace

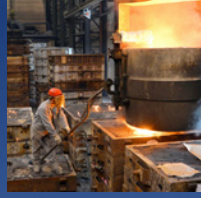

Process



Movement



Energy



Extraction



Your system supplier for every aspect of power transmission

We say what we mean and mean what we say.

We see things from our customers' perspective.

We are considerate of our employees and their families as well as of our environment and society.



RINGFEDER POWER TRANSMISSION is the global market leader in the niche markets of drive technology and is well regarded for its customer-specific, application-oriented solutions that ensure excellent and failure-free operation for its clients. We offer locking devices, damping technology and couplings for OEMs but also for the final customer under our strong brand name RINGFEDER®.

We do not only provide competent advice to our customers on the basis of our 90 years of experience but also develop innovative ideas in cooperation with them. This is part of our aspiration to be a **Partner for Performance**.

Around the power transmission we promise

- Excellent know-how for our challenging customers
- Best cost-benefit ratio
- Short reaction times and a high product availability





Know-how

Over 90 years of expertise.

On-site worldwide

We are there for you. Anytime, anywhere.

Your expert partner

From development to the finished product.

Customer

Value

Online calculation program

Always find the right solution.

Your projects are our drive

Know-how: Over 90 years of expertise.

Rely on decades of engineering expertise from the inventor of the friction spring. As an expert in drive and damping technology, we are your reliable partner wherever forces are at work. Be it the permanent transfer of very high torques due to non-positive or positive connections or the absorption and trapping of extreme energies to protect expensive constructions.

Your expert partner: From development to the finished product.

We accompany you through to the successful completion of your project. Beginning with the development phase of your project, we offer our know-how and professional solutions. By working together with global market leaders and as an international supplier of outstanding products and special solutions, we are a reliable partner for you.

Online calculation program: Always find the right solution.

In response to the complex requirements involved in the correct selection and design of the required products under practical conditions, we have developed our online calculation program. Engineers and experts are able to calculate transferable torques and other important values, taking into account various parameters. Visit our website www.ringfeder.com!

On-site worldwide: We are there for you. Anytime, anywhere.

With our locations in Germany, the Czech Republic, the USA, Brazil, China and India as well as a worldwide service and partner network, we are there for you around the clock. This ensures our support for the successful completion of your projects at any time.

Locking Assemblies Bending Loads

Introduction

Keyless shaft-hub locking devices have been the cornerstone of the RINGFEDER®. For over 90 years, our product offering of internal clamping and external clamping locking devices and global support has been unparalleled in the industry.

Characteristics

One of the most demanding challenges to our Locking Assemblies is the application in belt drums. The extreme additional load through bending moments has to be reliably absorbed by the Locking Assembly and requires the highest engineering know-how. Our international development team, which has already set benchmarks in quality Locking Assemblies for the RfN 7012, RfN 7012.2, RfN 7015.0 and RfN 7015.1 products, is now setting a further milestone with the Locking Assembly RfN 7515.

The new development of the RfN 7515 Locking Assemblies has set a new benchmark in this segment with its quality, performance and price range.

- **Quality means:** High-quality materials and material services and the most precise workmanship, guarantee sustainable product usage.
- **Performance means:** Reliability and long service life means: minimization of machine downtime and maximization of service life.
- **Price means:** Not just the newest, but also the most economical RINGFEDER® Locking Assembly product at the high level of performance you are used to.

Locking Assemblies self-centering

Self-centring RINGFEDER® Locking Assemblies enable extremely precise concentricity in the clamped components. The maximum concentricity error for the clamping sets that are machined in a clamping process is an extremely low 0.04 mm. These clamping sets are used primarily in gear wheel mountings in rotary pumps and in machine tools that require the highest level of precision.

Locking Assemblies without axial displacement

RINGFEDER® Locking Assemblies without axial displacement of the hub during assembly are used when this kind of displacement would affect the function of the connection negatively. This kind of clamp set is used primarily in the area of machine tools, helical gear wheels, rotary table drives, pumps and brake disc mountings.

Locking Assemblies with low surface pressures

RINGFEDER® Locking Assemblies with low surface pressures minimise the tension in the components jointed by the set. They are used mainly in the case of extremely thin-walled hubs and for hubs with low yield strength or made of grey cast iron or aluminium. Aluminium timing belt pulleys and thin-walled levers are typical areas of use.

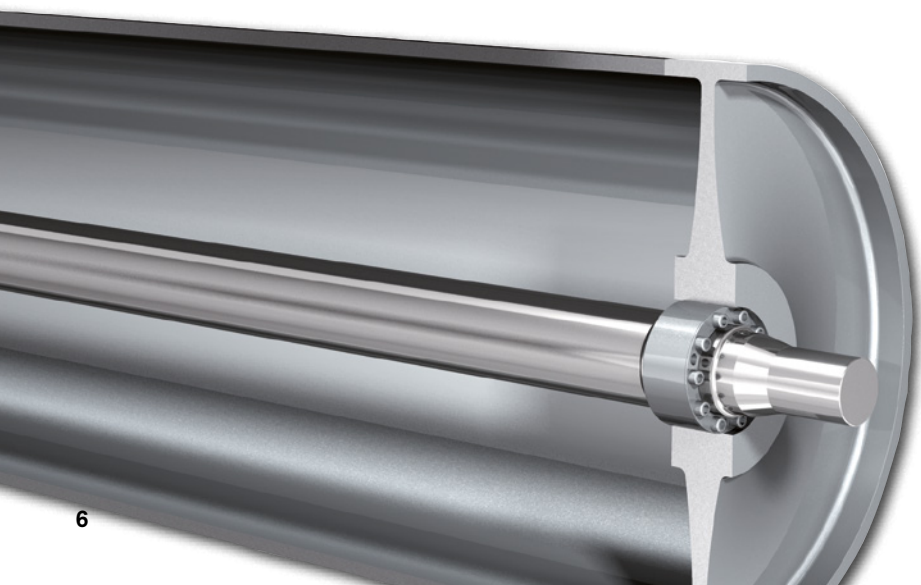

Disclaimer of liability

All technical details and notes are non-binding and cannot be used as a basis for legal claims. The user is obligated to determine whether the represented products meet his requirements. We reserve the right to carry out modifications at any time in the interests of technical progress.

Special surfaces for RINGFEDER® premium products

All RINGFEDER® premium products are smooth-ground as standard using a process specially developed for us. Account to this special quality feature, a consistent reproducible coefficient of friction is achieved for all Locking Assembly contact surfaces.

This exceptionally important reproducibility guarantees the consistent of defined pressure on which all Locking Assembly technical values are based.

Merely turned surfaces, even those which are precision-turned, have slip-stick effects if the cone is displaced. A type of indenting also takes place. The considerable coefficient of friction deviations which occur due to this affect the pressure, the torque transfer and the stresses in all components. Removal of the Locking Assembly is also made considerably more difficult.



Surface roughness measurement



Hardness measurement

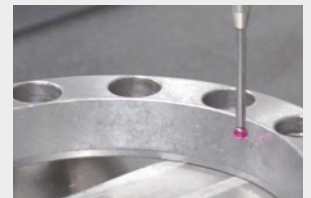

3D measurement



RINGFEDER® Locking Assemblies Bending Loads

RINGFEDER®	Transmissible torques T [Nm]	Shaft diameter d [mm]	self-centering	without axial displacement	with low surface pressure
RfN 7012 Bending Loads	9 591 – 1 960 015	100 – 1000		●	
RfN 7012.2 Bending Loads	10 409 – 1 359 784	100 – 800		●	
RfN 7015.0 Bending Loads	11 297 – 2 184 768	100 – 800	●	●	
RfN 7015.1 Bending Loads	6 575 – 1 054 312	100 – 800	●	●	●
RfN 7515 Bending Loads	4 299 – 1 300 152	60 – 640	●		

Locking Assembly selection on www.ringfeder.com

Our website offers you a selection tool that will help you to determine which locking assembly is suitable for you.

Following selection criteria are available:

- **transmissible torque at given T_A or shaft diameter**

Additional filter criteria:

- **axial displacement** (with or without)
- **self-centering** (yes or no)

Technical Information

Pressures and stresses in Locking Assembly taking bending moment into consideration

Without bending moment loading, pressure on the contact areas of the Locking Assembly between the shaft and drum end disc are evenly distributed. Under bending moment, the pressure increases on one side and decreases rotary on the opposing side during each drum rotation.

In this case, the stresses in the Locking Assembly between the bores on the side with higher pressure are subject to extreme increases, and these can destroy Locking Assemblies made of too soft or low-quality materials very quickly.

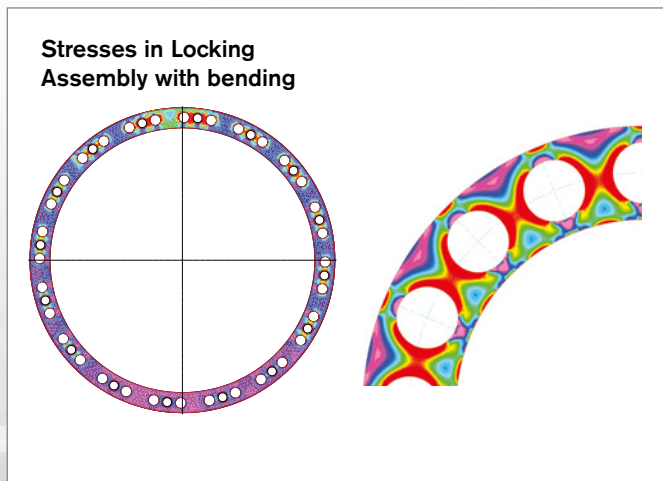
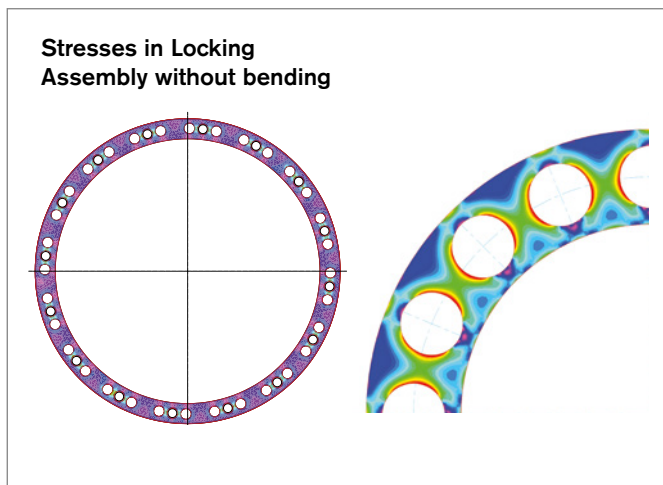
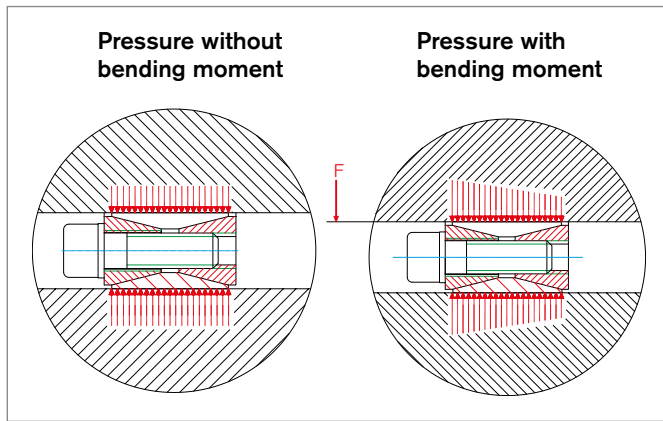

Influence of Locking Assembly width on pressure under bending moment loading

Ever wider the Locking Assembly, so much larger the leverage. In other words, larger Locking Assembly widths produce lower leverage. This means that pressure changes under bending loads are lower for wider Locking Assemblies, which in turn means that their behaviour under bending moment loads are more advantageous.

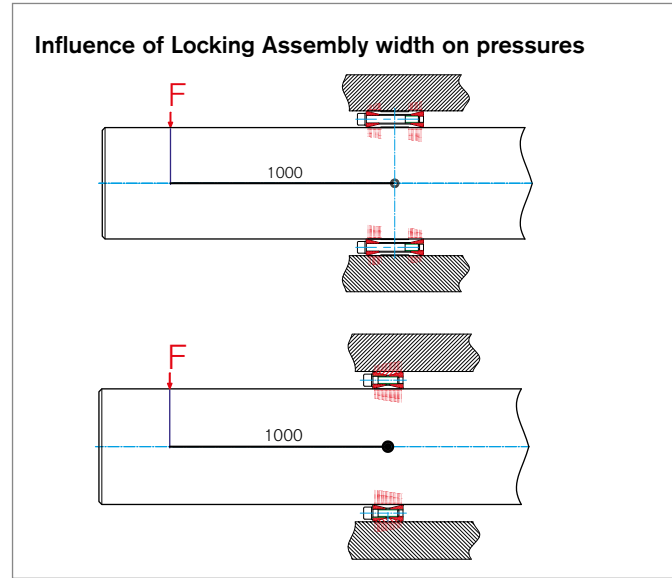

Shaft breakage due to friction corrosion

The Locking Assembly can be subject to localised lifting on the side with lower pressure. Micro-movements between the Locking Assembly and the adjacent components occur. The fretting corrosion which results from this causes surface damage, which can lead to cracks or even shaft breakage in worst cases.

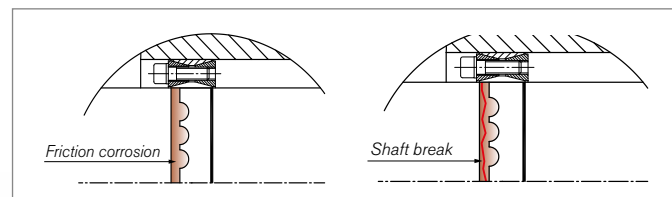

Shaft breakage

Hub loads due to pressure increases

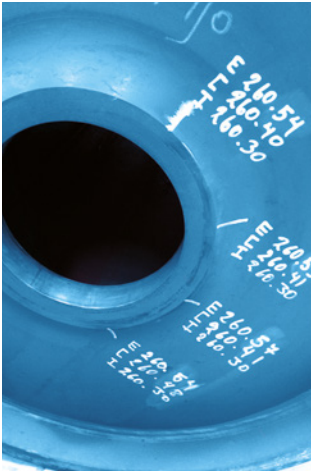

Deformed drum end disc

The hub (drum end disc) is loaded over its whole circumference by the increased pressures. This means it is imperative that the drum end disc is designed to meet the maximum occurring pressure.

Drum end disc which have been designed to weakly deform in a plastic manner and lead to connection failures. Drive pulleys slip if the drum end disc deforms in a plastic manner and tail pulleys start to „move“ axially.

Influence of material strength on transmissible bending moment

The loading limits can be considerably increased for applications which fall below the stated web stresses for the standard RfN 7012 Locking Assembly through the use of Locking Assemblies made of high-quality materials, e.g.: RfN 7012.2 (here, the material yield strength is around 40% greater than that of the standard Locking Assembly). This results in a tripling of the transmissible bending moment.

Influence of number of bores on stresses in Locking Assemblies

The number of bores made, which weaken the pressure ring, significantly influences the stresses in the Locking Assembly. Stresses can be considerably reduced through the use of lower number of bores and the reserves made available by this can be used for additional bending moment loads.

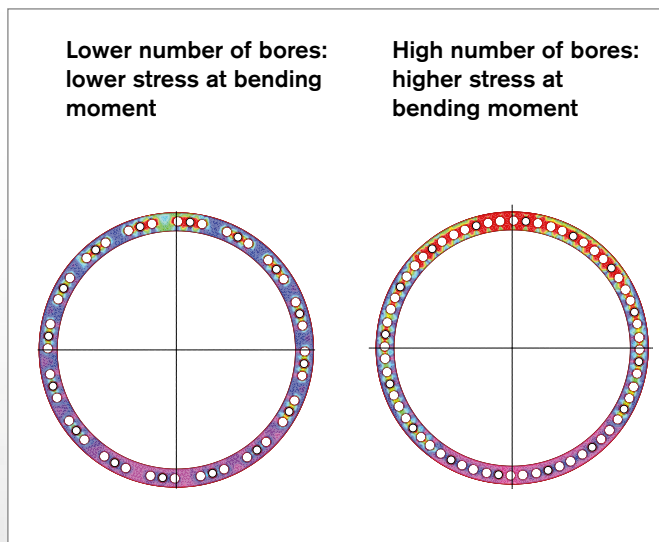

Bolt failure under excessive bending moment

The shaft deflection caused by the circumferential belt tension applies load to the clamping bolts every drum rotation. This additional axial loading leads to fatigue failures and bolt head breakage if the bolts are fully tightened. For this reason, the bolt tightening torques must be reduced depending on the series if Locking Assembly applications are subject to bending moments.

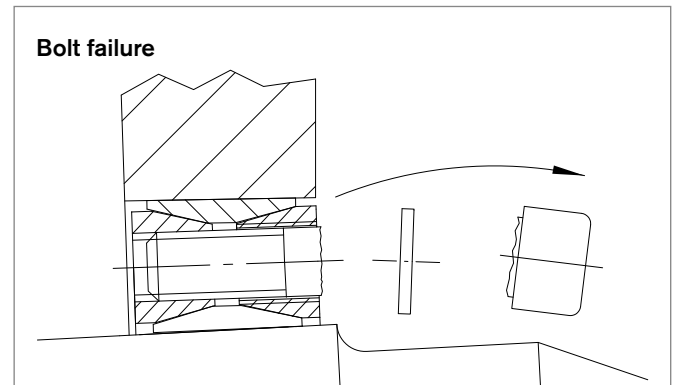

Bolt failure by hydrogen embrittlement

For use at wet moistness exists the danger of hydrogen embrittlement of the screws, therefore we advise here the use of zinc flake coated screws. These screws are used as standard on the series RfN 7012.2:



Bolt failure

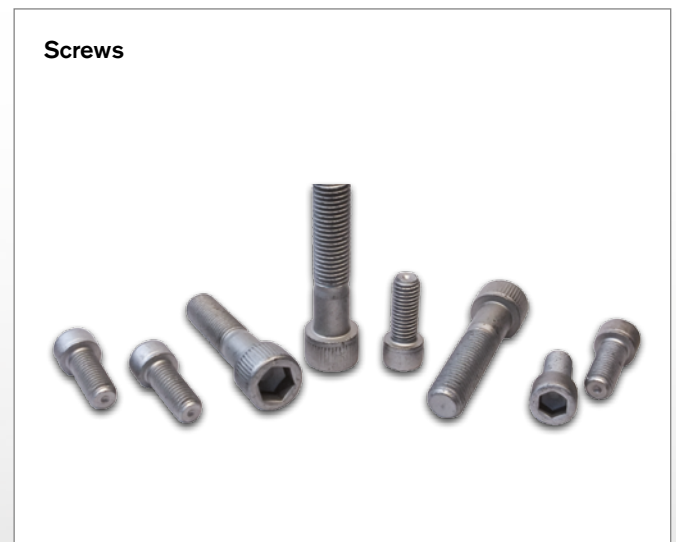

Technical Information

Shaft torsion and therefore no torque division on both drum ends

The shaft is torsionally softer than the drum body. For this reason, the entire torque must be transferred to the drive side. Torque division on both Locking Assemblies results in the destruction of the Locking Assembly on the drive side (see drawing).

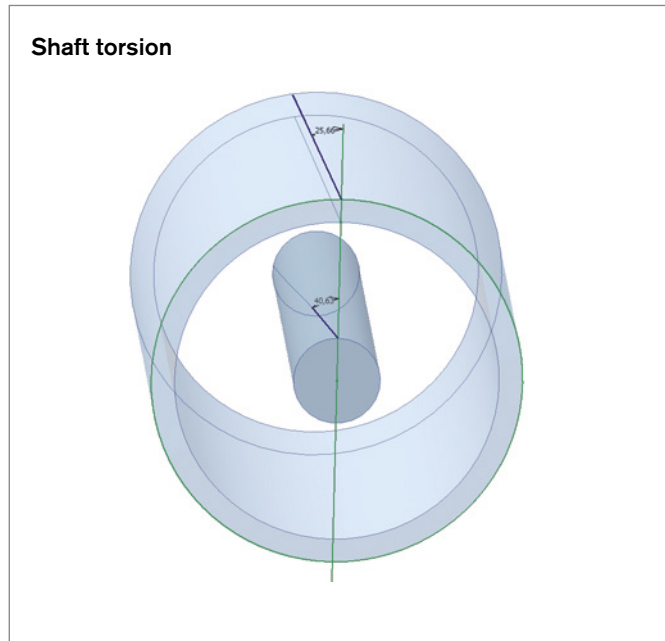

Start-up factor for belt drives

When belt equipment starts up, the electric motor briefly applies around 2.5 times the nominal torque. The drum fixing therefore needs to be designed to accept the start-up torque loading. Hydraulic or Magnetic centrifugal couplings significantly reduce this factor. If not, the connection slips or the Locking Assembly is destroyed after a short time.

Bending moment division between shaft and drum end disc

The Locking Assembly must transfer the entire bending moment if the end disc is very stiff. If the drum end disc is flexible, the bending moment to be transferred is divided between the end disc and drum shaft - the stresses from the bending moment are reduced and the Locking Assembly is protected.

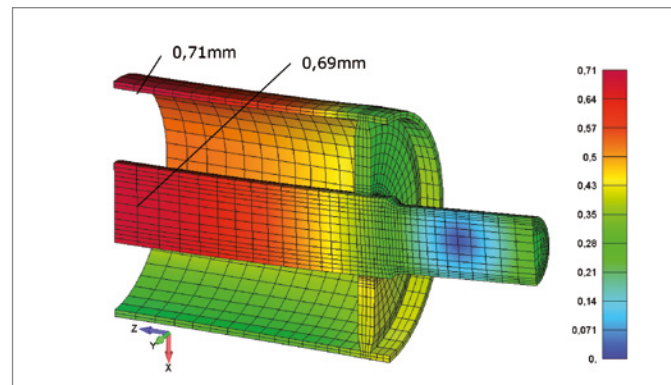
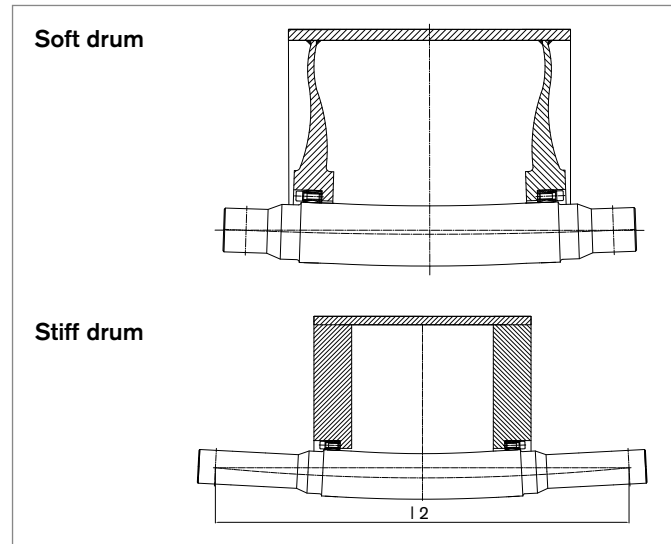

Deformation on an belt drum

Function between bending moment, torque, pressure and bolt tightening torque

Example values from calculation for 400 x 495 RfN 7012				
T_a	M_b	p_w	p_n	$T_{res.}$
Nm	Nm	N/mm ²	N/mm ²	Nm
780	0	123	99	311738
780	150460	217	175	273024
468	0	74	60	187043
468	118100	148	119	145043
780	160000	224	181	267545
Sample values from calculation for 400 x 495 RfN 7012.2				
780	160000	236	191	304646
780	217300	272	220	266814

- This Locking Assembly was destroyed by overloading
- This Locking Assembly is able to transfer the required loads

Belt drum mounted using Locking Assemblies RfN 7015

With this and similar constructions the main criterion is to be found in the admissible bending load. For limitation of this load we have on condition of elastic drum bottoms up to now determined a certain shaft deflection as related to the bearing distance and thus as corresponding angle of deflection at the fitting point of the Locking

Assembly. Thus, an angle deflection $< 5,4'$ or the maximum shaft deflection f_m as related to the bearing distance „ l “ were permitted at $1/2000$. Constructions based on these experimental values can, however, be optimized by designing in accordance with the permissible bending moment of the Locking Assembly used.

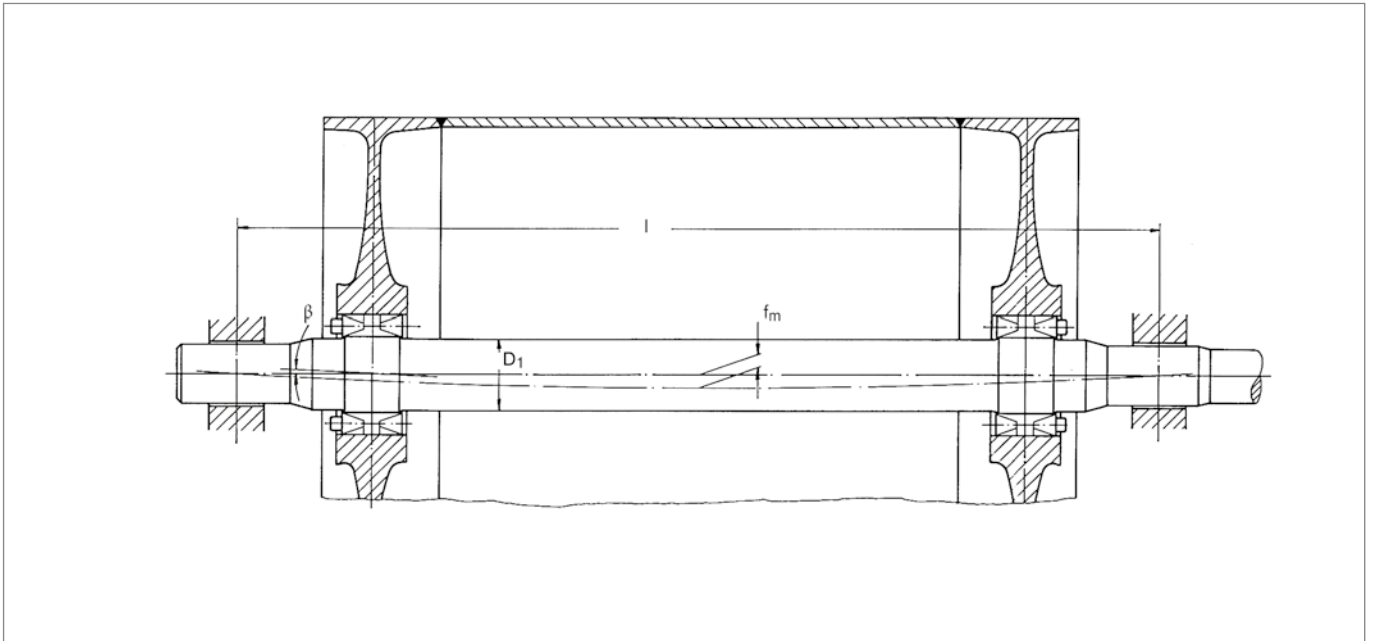

Distribution of surface pressures

The chosen diagram shows the correlation between the surface pressures derived from the clamping and the bending moment. Basic

limitations for the superposition of those surface pressures are additionally shown.

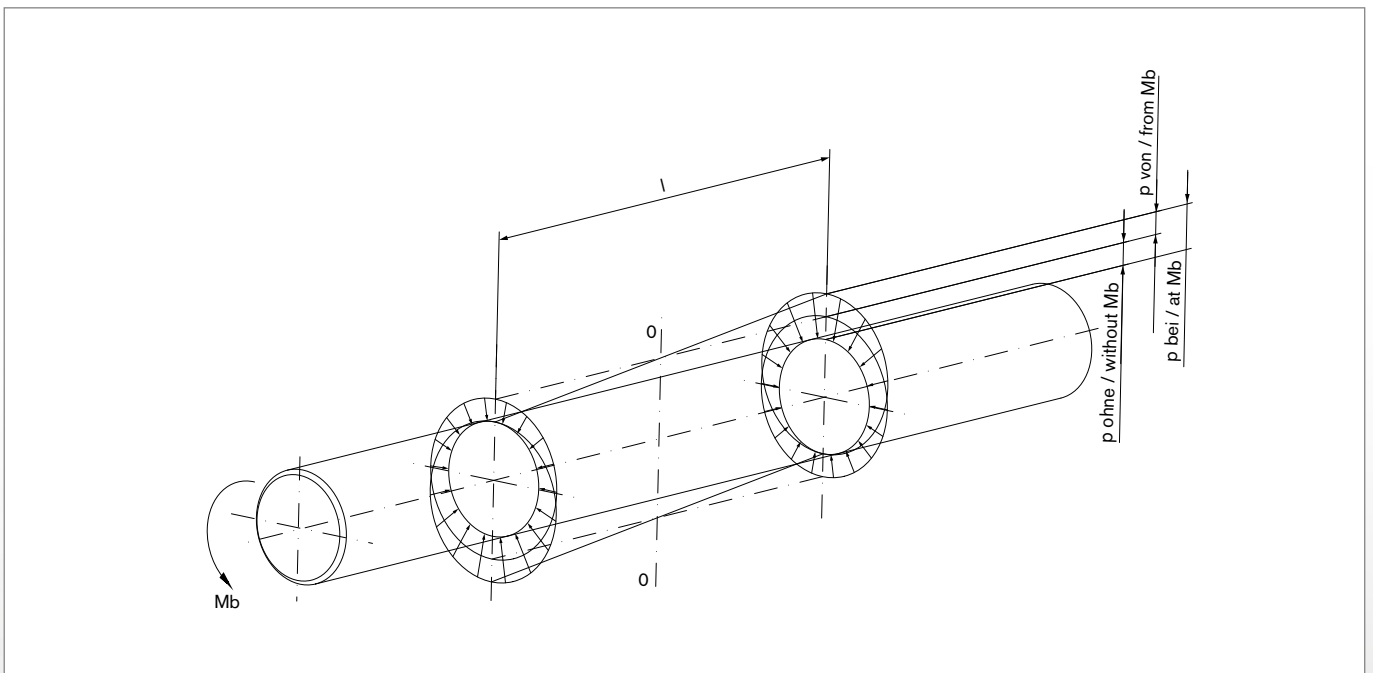



RfN 7012

Further information on
RINGFEDER® RfN 7012
 Bending Loads
 on www.ringfeder.com

- self-centering
- without axial displacement**
- with low surface pressure

Extreme loads in belt drums

The bending moment acting on the hub/shaft connection is the main load to evaluate in a belt drum or similar application. Excessive bending moments can cause overstress in the webs between the screw holes in the locking assembly. In the case of additional loads (bending moments/ radial loads) screw tightening torques may have to be reduced.

To limit the influence of the bending load on the locking assembly connection we use the following criteria during the belt drum design process:

- Shaft deflection from the bending moments can only have a maximum deflection $f_m < 1/2000 \times L$ (bearing centre distance)
- For the permissible bending load values please refer to our tables.

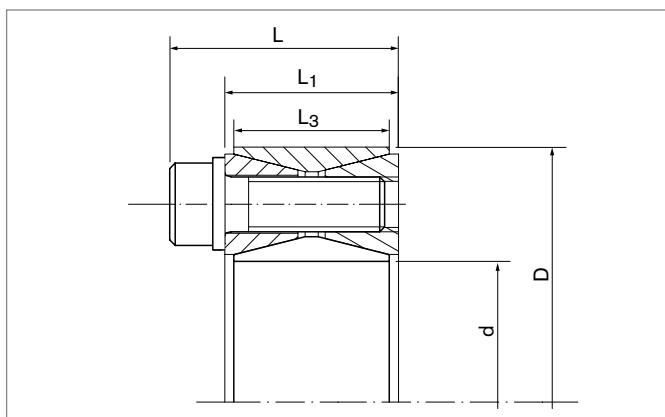

Characteristics

One of the most demanding challenges on our promise of performance is the belt drum application field. The extreme loads which such components are subject to, especially the high bending moment, coupled with the simultaneous indispensable reliability and longest-possible service life require the highest in engineering know-how. Our international development team, which has already set benchmarks in quality Locking Assemblies for the RfN 7012, RfN 7012.2, RfN 7015.0 and RfN 7015.1 products, is now setting a further milestone with the Locking Assembly RfN 7515.

- **Quality means:** High-quality materials and material services and the most precise workmanship, guarantee sustainable product usage.
- **Performance means:** Reliability and long service life means: minimization of machine downtime and maximization of service life.
- **Price means:** Not just the newest, but also the most economical RINGFEDER® Locking Assembly product at the high level of performance you are used to.



Further information on
RINGFEDER® RfN 7012.2
Bending Loads
on www.ringfeder.com

self-centering
without axial displacement
with low surface pressure

Specially developed for use in belt drums

The new Locking Assembly series RINGFEDER® RfN 7012.2 is specially designed to fulfil the requirements of constantly increasing bending moments for conveyor pulleys.

The challenge was to develop a product with the same dimensions as the standard RINGFEDER® RfN 7012 to fit into existing end discs – Attention: yield point of end disc has to be checked – so that also material handling equipment at hand can be upgraded.

At the same time the Locking Assembly should carry a multiple of the bending moments of the standard RINGFEDER® RfN 7012.

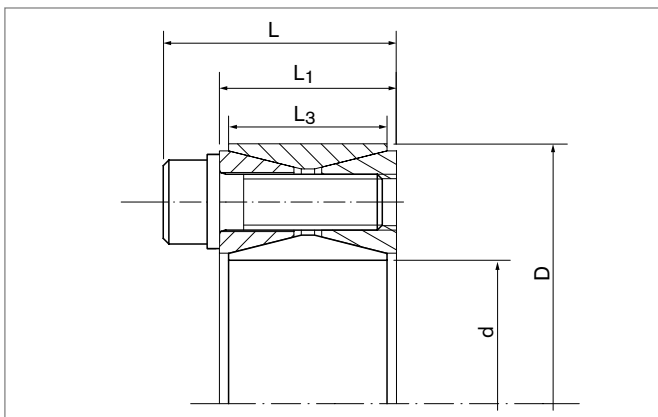

Characteristics

One of the most demanding challenges on our promise of performance is the belt drum application field. The extreme loads which such components are subject to, especially the high bending moment, coupled with the simultaneous indispensable reliability and longest-possible service life require the highest in engineering know-how. Our international development team, which has already set benchmarks in quality Locking Assemblies for the RfN 7012, RfN 7012.2, RfN 7015.0 and RfN 7015.1 products, is now setting a further milestone with the Locking Assembly RfN 7515.

- **Quality means:** High-quality materials and material services and the most precise workmanship, guarantee sustainable product usage.
- **Performance means:** Reliability and long service life means: minimization of machine downtime and maximization of service life.
- **Price means:** Not just the newest, but also the most economical RINGFEDER® Locking Assembly product at the high level of performance you are used to.



RfN 7015.0

Further information on
RINGFEDER® RfN 7015.0
Bending Loads
on www.ringfeder.com

- self-centering
- without axial displacement
- with low surface pressure

Transfer of bending moments possible, highest torque and/or axial forces, excellent concentricity

Precision locking assemblies for the transfer of the highest torques and/or axial forces with special requirements for the concentricity of the parts to be clamped and for applications with bending moments.

Combined loads from bending moments and radial loads can be transferred.

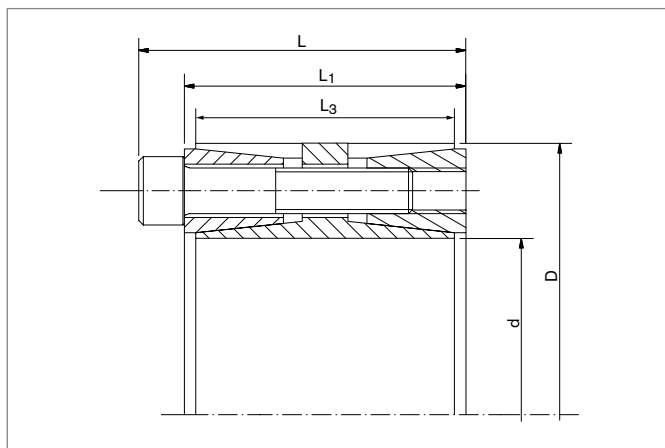

Characteristics

One of the most demanding challenges on our promise of performance is the belt drum application field. The extreme loads which such components are subject to, especially the high bending moment, coupled with the simultaneous indispensable reliability and longest-possible service life require the highest in engineering know-how. Our international development team, which has already set benchmarks in quality Locking Assemblies for the RfN 7012, RfN 7012.2, RfN 7015.0 and RfN 7015.1 products, is now setting a further milestone with the Locking Assembly RfN 7515.

- **Quality means:** High-quality materials and material services and the most precise workmanship, guarantee sustainable product usage.
- **Performance means:** Reliability and long service life means: minimization of machine downtime and maximization of service life.
- **Price means:** Not just the newest, but also the most economical RINGFEDER® Locking Assembly product at the high level of performance you are used to.



Further information on
RINGFEDER® RfN 7015.1
 Bending Loads
 on www.ringfeder.com

Reduced surface pressures

Precision locking assemblies for the transfer of the highest torques and/or axial forces with special requirements for the concentricity of the parts to be clamped and for applications with bending moments.

The locking assembly RfN 7015.1 is characterised by lower surface pressure on the shaft and hub.

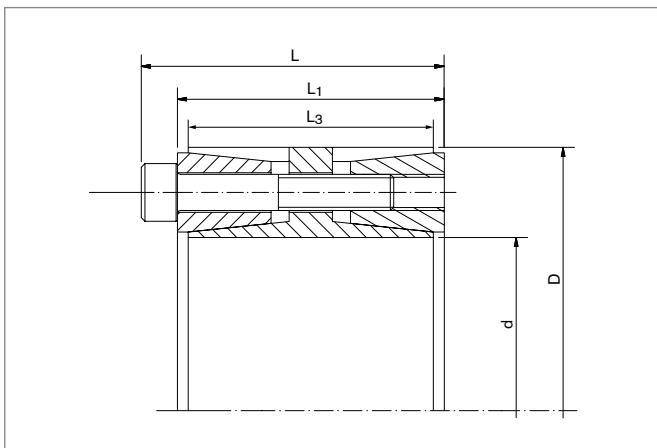

Characteristics

One of the most demanding challenges on our promise of performance is the belt drum application field. The extreme loads which such components are subject to, especially the high bending moment, coupled with the simultaneous indispensable reliability and longest-possible service life require the highest in engineering know-how. Our international development team, which has already set benchmarks in quality Locking Assemblies for the RfN 7012, RfN 7012.2, RfN 7015.0 and RfN 7015.1 products, is now setting a further milestone with the Locking Assembly RfN 7515.

- **Quality means:** High-quality materials and material services and the most precise workmanship, guarantee sustainable product usage.
- **Performance means:** Reliability and long service life means: minimization of machine downtime and maximization of service life.
- **Price means:** Not just the newest, but also the most economical RINGFEDER® Locking Assembly product at the high level of performance you are used to.



RfN 7515

Further information on
RINGFEDER® RfN 7515
 Bending Loads
 on www.ringfeder.com

self-centering
without axial displacement
with low surface pressure

Three part Locking Assembly

Especially for the bending moment transmission designed 3 part Locking Assembly with reduced stresses in the Locking Assembly itself.

Special Features - Through the long and flat cones one Locking Assembly RfN 7515 can transmit torques and axial forces and bending loads. At mounting is a small axial movement from Locking Assembly and hub.

Bending moment and radial loads – combined loads can be transmitted (Please contact our specialists for assistance).

Excellent centering ability – with a relatively wide design.

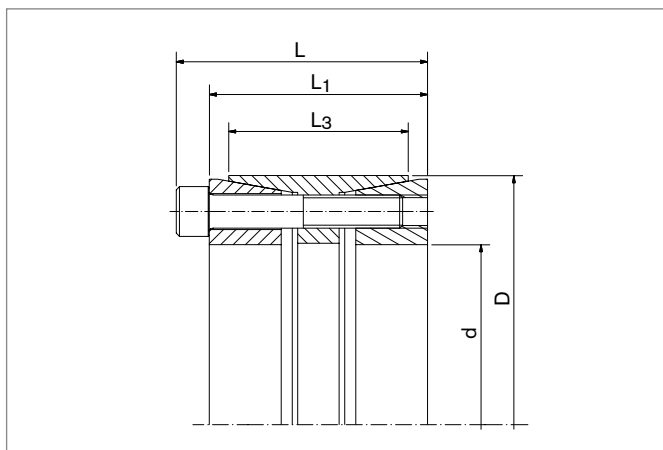

Characteristics

One of the most demanding challenges on our promise of performance is the belt drum application field. The extreme loads which such components are subject to, especially the high bending moment, coupled with the simultaneous indispensable reliability and longest-possible service life require the highest in engineering know-how. Our international development team, which has already set benchmarks in quality Locking Assemblies for the RfN 7012, RfN 7012.2, RfN 7015.0 and RfN 7015.1 products, is now setting a further milestone with the Locking Assembly RfN 7515.

- **Quality means:** High-quality materials and material services and the most precise workmanship, guarantee sustainable product usage.
- **Performance means:** Reliability and long service life means: minimization of machine downtime and maximization of service life.
- **Price means:** Not just the newest, but also the most economical RINGFEDER® Locking Assembly product at the high level of performance you are used to.



Calculation

Equations for thick-walled cylinders give good service in the estimation of the tangential (tension) stresses occurring in the hub and hollow shaft. Exact determination of the true stresses and deformations (expanding, contraction) is very difficult in view of the

wide scatter of the coefficients of friction and because of the differing hub and hollow shaft configurations. Constructions in which Locking Assemblies are intended to be arranged under or above bearings should therefore be avoided as far as possible, or be more closely investigated (e. g. test clamping).

Hub calculation

- 1) $p_N \approx p_W \cdot \frac{d}{D}$
- 2) $a_N = \frac{D_N}{D}$
- 3) $\sigma_{tiN} = \frac{p_N(a_N^2 + 1)}{a_N^2 - 1}$; $L_N = L_3$
- 4) $\sigma_{taN} = \frac{2 \cdot p_N}{a_N^2 - 1}$; $L_N = L_3$
- 5) $\sigma_{tiN} = \frac{C_3 \cdot p_N \cdot (a_N^2 + 1)}{a_N^2 - 1}$; $L_N > 2L_3$
- 6) $\sigma_{taN} = \frac{C_3 \cdot p_N \cdot 2}{a_N^2 - 1}$; $L_N > 2L_3$
- 7) $D_N \cong D \cdot \sqrt{\frac{R_{p0,2N} + C_3 \cdot p_N}{R_{p0,2N} - C_3 \cdot p_N}}$ a)
- 8) $D_N \cong D \cdot \sqrt{\frac{R_{p0,2N} + C_3 \cdot p_N}{R_{p0,2N} - C_3 \cdot p_N} + 2D_G}$ b)
- 9) $\Delta D_N \approx \frac{D_N \cdot \sigma_{taN}}{E_N}$ c)
- 10) $p_{Nzul.} \approx \frac{R_{p0,2N}}{C_3} \cdot \frac{D_N^2 - D^2}{D_N^2 + D^2}$ a)

Shaft calculation

- 1) $a_W = \frac{d}{d_B}$
- 2) $\sigma_{tiW} \approx 2 \cdot p_W \cdot C_3 \cdot \frac{a_W^2}{a_W^2 - 1}$
- 3) $\sigma_{taW} \approx p_W \cdot C_3 \cdot \frac{a_W^2 + 1}{a_W^2 - 1}$
- 4) $d_B \cong d \cdot \sqrt{\frac{R_{p0,2W} - 2 \cdot p_W \cdot C_3}{R_{p0,2W}}}$ a)
- 5) $d_B \cong d \cdot \sqrt{\frac{R_{p0,2W} - 2 \cdot p_W \cdot C_3}{R_{p0,2W}} - 2D_G}$ b)
- 6) $\Delta d_B \approx \frac{d_B \cdot \sigma_{tiW}}{E_W}$
- 7) $\Delta d \approx \frac{p_W \cdot d \cdot (m - 1)}{E_W \cdot m}$ c)
- 8) $R_{p0,2W} > p_W$ c)
- 9) $p_{zul.} \approx \frac{R_{p0,2W} \left[1 - \left(\frac{d_B}{d} \right)^2 \right]}{C_3 \cdot 2}$ a)

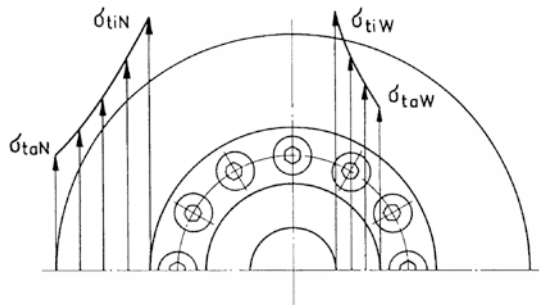
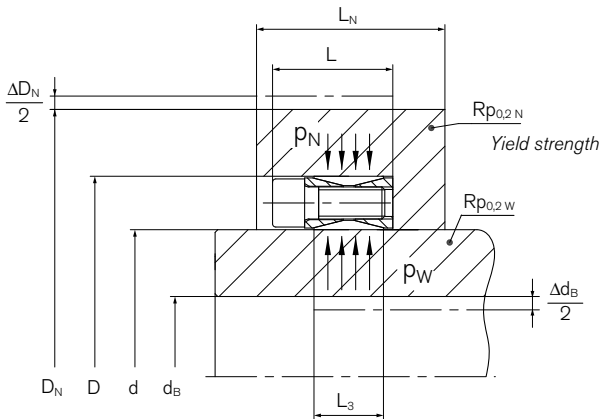

Sectional views

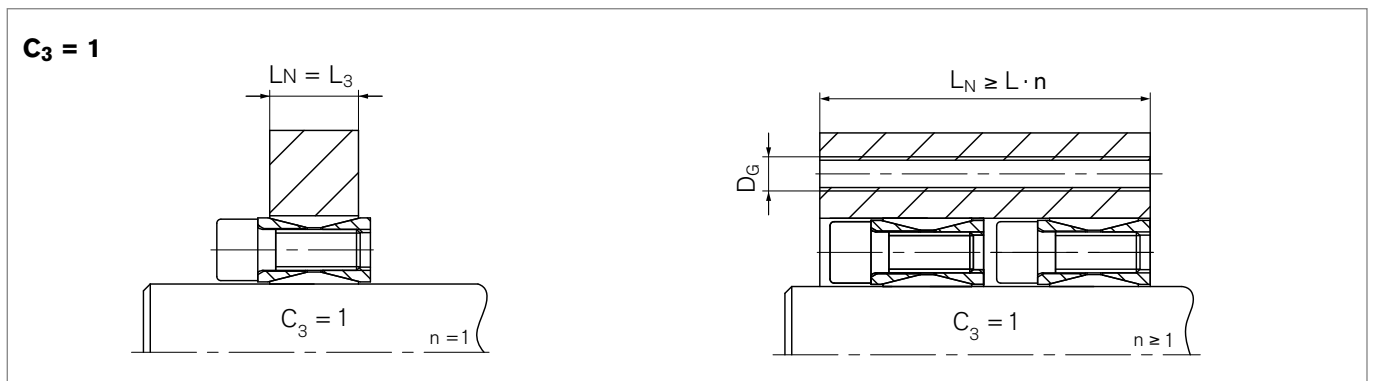
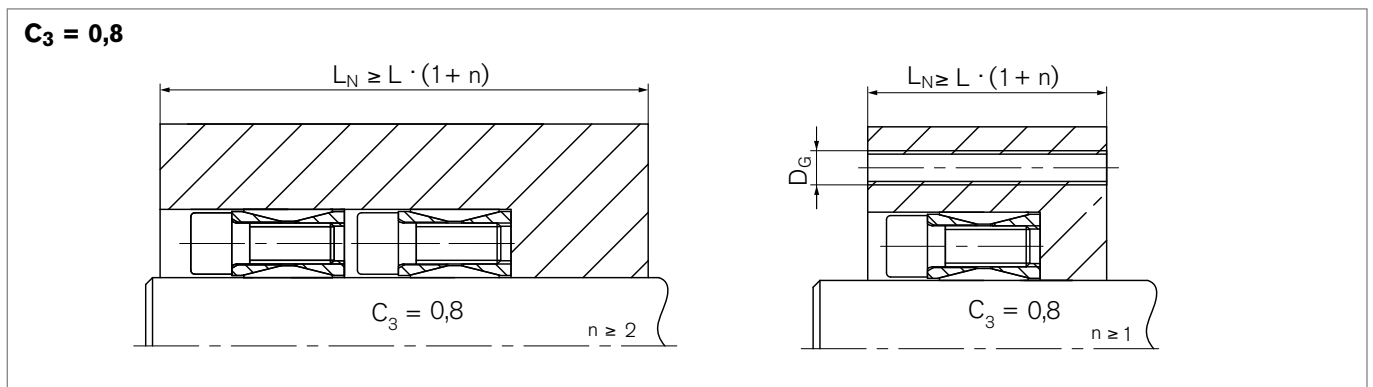
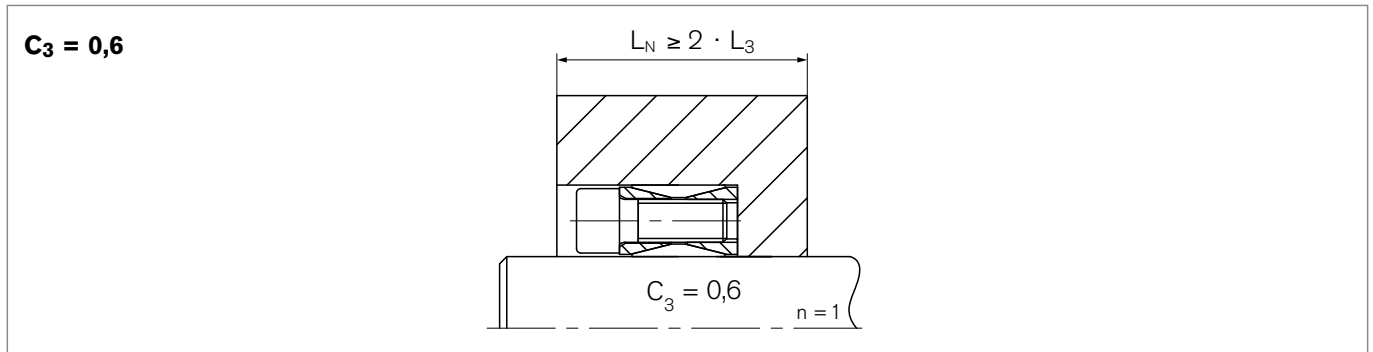

Explanation

a) Cross section of the hub above the Locking Assembly, unweakened

$C_3 = 0,6$ for one Locking Assembly and $L_N \geq 2 \cdot L_3$

$C_3 = 0,8$ for two or more Locking Assemblies and $L_N \geq L \cdot (1 + n)$; n = number of Locking Assemblies

$C_3 = 1$ for one or more Locking Assemblies and $L_N = L_3$ resp. $L_N = L \cdot n$

b) If bores or threads (D_G) in the hub

$C_3 = 0,8$ if $L_N \geq 2 \cdot L_3$ resp. $L_N \geq L \cdot (1 + n)$

$C_3 = 1$ if $L_N = L_3$ resp. $L_N = L \cdot n$

c) Approximated value. A higher scatter range is possible, as the value depends on the actual coefficient of friction and the shape of the hub.



Locking Assemblies Bending Loads **RINGFEDER®**

Tables & Values



Locking Assemblies Bending Loads

RINGFEDER® RfN 7012

Extreme loads in belt drums



self-centering **without axial displacement** with low surface pressure

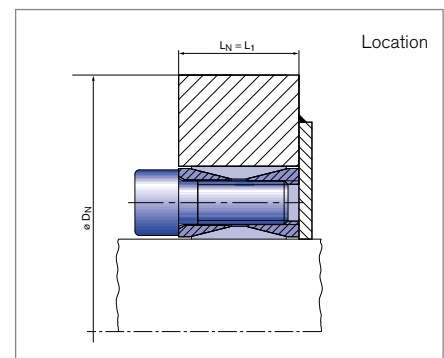
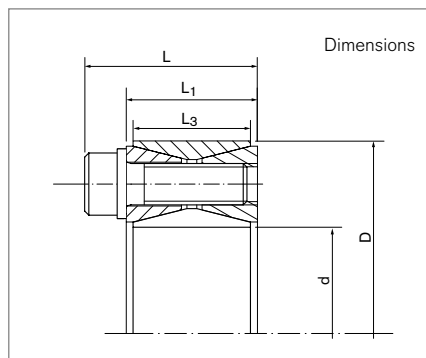

Locking Assembly dimensions				Locking screws													D _{N min} at Rp _{0,2}			G _w			
d	x	D	L	L ₁	L ₃	n _{Sc}	D _G	T _{Ared}	T	F _{ax}	P _w	p _N	M _{bmax}	P _{wmax} at M _{bmax}	P _{Nmax} at M _{bmax}	P _{wmin} at M _{bmax}	P _{Nmin} at M _{bmax}	T _{res} at M _{bmax}	F _{ax} at M _{bmax}		250	350	450
mm				mm					Nm	Nm	N/mm ²		Nm	N/mm ²				Nm	kN	[N/mm ²]			kg
100	x	145	47	33	26	14	M12 x 30	125	9591	192	196	135	7210	331	228	60	41	6325	126	---	317	255	2,01
110	x	155	47	33	26	14	M12 x 30	125	10488	191	177	126	7840	311	221	43	30	6966	127	---	326	266	2,15
120	x	165	47	33	26	16	M12 x 30	125	13004	217	184	134	8960	325	236	44	32	9425	157	---	375	296	2,35
130	x	180	52	38	34	20	M12 x 35	125	17522	270	162	117	11310	285	206	38	28	13383	206	---	355	296	3,51
140	x	190	52	38	34	22	M12 x 35	125	20661	295	164	121	10160	268	197	61	45	17991	257	---	360	305	3,85
150	x	200	52	38	34	24	M12 x 35	125	24046	321	167	125	9020	252	189	81	61	22290	297	---	367	314	4,07
160	x	210	52	38	34	26	M12 x 35	125	27674	346	169	129	7870	239	182	99	75	26532	332	---	374	323	4,3
170	x	225	60	44	38	22	M14 x 40	190	32486	382	157	119	21570	291	220	22	17	24292	286	---	473	385	5,78
180	x	235	60	44	38	24	M14 x 40	190	37391	415	161	123	18960	273	209	49	38	32227	358	---	469	390	6,05
190	x	250	68	52	46	28	M14 x 45	190	45890	483	147	111	24070	242	184	51	39	39071	411	---	449	387	8,25
200	x	260	68	52	46	30	M14 x 45	190	51590	516	149	114	21150	228	176	69	53	47056	471	623	453	394	8,65
220	x	285	74	56	50	26	M16 x 50	295	66374	603	146	112	32670	242	187	49	38	57777	525	---	518	444	11,22
240	x	305	74	56	50	30	M16 x 50	295	83094	692	153	120	20330	208	164	98	77	80569	671	669	508	448	12,2
260	x	325	74	56	50	34	M16 x 50	295	101512	781	159	127	16810	201	161	117	94	100111	770	700	536	474	13,2
280	x	355	86,5	66	60	32	M18 x 60	405	124233	887	140	111	38440	204	161	76	60	118136	844	764	585	517	19,2
300	x	375	86,5	66	60	36	M18 x 60	405	149101	994	146	117	24820	185	148	108	86	147020	980	742	590	529	20,5
320	x	405	100,5	78	72	36	M20 x 70	580	207104	1294	149	118	37220	188	148	110	87	203732	1273	803	638	571	29,6
340	x	425	100,5	78	72	36	M20 x 70	580	219216	1290	140	112	57920	196	157	83	66	211426	1244	891	690	613	31,1
360	x	455	116	90	84	36	M22 x 80	780	282418	1569	138	109	74630	189	150	86	68	272379	1513	910	720	644	42,2
380	x	475	116	90	84	36	M22 x 80	780	297102	1564	130	104	87000	187	150	73	58	284078	1495	949	751	672	44
400	x	495	116	90	84	36	M22 x 80	780	311738	1559	123	99	150460	217	175	29	23	273024	1365	1183	860	748	46
420	x	515	116	90	84	40	M22 x 80	780	362587	1727	130	106	93580	186	151	74	60	350303	1668	1039	819	732	50
440	x	545	130	102	96	40	M24 x 90	1000	442836	2013	126	102	113140	176	142	76	62	428139	1946	1041	840	757	64,6
460	x	565	130	102	96	40	M24 x 90	1000	461680	2007	121	98	177330	195	159	46	37	426266	1853	1200	924	819	67,4
480	x	585	130	102	96	42	M24 x 90	1000	504497	2102	121	99	168140	189	155	53	43	475653	1982	1209	943	839	71
500	x	605	130	102	96	44	M24 x 90	1000	549139	2197	121	100	158960	183	151	60	49	525629	2103	1221	962	859	72,6
520	x	630	130	102	96	45	M24 x 90	1000	582655	2241	119	98	194480	192	158	46	38	549239	2112	1330	1027	911	80

To continue see next page

Locking Assemblies Bending Loads RINGFEDER® RfN 7012

Locking Assembly dimensions				Locking screws															D _{N min} at R _{p0,2}			G _w	
d	x	D	L	L ₁	L ₃	n _{Sc}	D _G	T _{Ared}	T	F _{ax}	p _w	p _N	M _{bmax}	p _{wmax} at M _{bmax}	p _{Nmax} at M _{bmax}	p _{wmin} at M _{bmax}	p _{Nmin} at M _{bmax}	T _{res} at M _{bmax}	F _{ax} at M _{bmax}	250 350 450 [N/mm ²]			
mm			mm					Nm	Nm	N/mm ²	Nm	N/mm ²						Nm	kN	mm			kg
540	x	650	130	102	96	45	M24 x 90	1000	603639	2236	114	95	258670	207	172	21	18	545408	2020	1516	1115	974	82
560	x	670	130	102	96	48	M24 x 90	1000	666213	2379	117	98	212800	191	160	44	36	631313	2255	1429	1098	972	85
580	x	690	130	102	96	50	M24 x 90	1000	717182	2473	118	99	203610	186	156	50	42	687672	2371	1438	1117	992	88
600	x	710	130	102	96	50	M24 x 90	1000	740342	2468	114	96	267800	200	169	27	23	690210	2301	1619	1204	1055	91
620	x	730	130	102	96	52	M24 x 90	1000	793992	2561	114	97	258610	195	166	33	28	750696	2422	1622	1222	1075	93
640	x	750	130	102	96	54	M24 x 90	1000	849441	2655	115	98	249429	190	162	39	33	811994	2537	1628	1240	1095	96
660	x	770	130	102	96	56	M24 x 90	1000	906684	2748	115	99	240240	186	159	44	38	874277	2649	1635	1259	1115	99
680	x	790	130	102	96	56	M24 x 90	1000	932418	2742	111	96	304420	198	171	25	21	881324	2592	1821	1347	1179	102
700	x	810	130	102	96	60	M24 x 90	1000	1026541	2933	116	100	221870	177	153	54	47	1002277	2864	1654	1296	1156	104
720	x	830	130	102	96	60	M24 x 90	1000	1054013	2928	112	97	286050	189	164	35	31	1014455	2818	1827	1383	1218	107
740	x	850	130	102	96	62	M24 x 90	1000	1117486	3020	113	98	276870	185	161	40	35	1082644	2926	1833	1401	1238	110
760	x	870	130	102	96	64	M24 x 90	1000	1182737	3112	113	99	267680	182	159	45	39	1152048	3032	1840	1419	1258	113
780	x	890	130	102	96	65	M24 x 90	1000	1230829	3156	112	98	295180	185	162	38	34	1194909	3064	1931	1472	1300	116
800	x	910	130	102	96	66	M24 x 90	1000	1279783	3199	111	97	322680	189	166	32	28	1238436	3096	2026	1525	1341	118
820	x	930	130	102	96	68	M24 x 90	1000	1349444	3291	111	98	313500	185	163	37	32	1312524	3201	2030	1543	1361	121
840	x	950	130	102	96	70	M24 x 90	1000	1420874	3383	111	98	304310	182	161	41	36	1387904	3305	2037	1561	1381	124
860	x	970	130	102	96	72	M24 x 90	1000	1494068	3475	112	99	295130	178	158	45	40	1464629	3406	2044	1579	1401	127
880	x	990	130	102	96	74	M24 x 90	1000	1569025	3566	112	100	285940	175	156	49	43	1542750	3506	2053	1598	1421	129
900	x	1010	130	102	96	75	M24 x 90	1000	1624087	3609	111	99	313440	178	159	43	38	1593554	3541	2142	1650	1462	132
920	x	1030	130	102	96	76	M24 x 90	1000	1680004	3652	110	98	340940	182	162	38	34	1645045	3576	2233	1702	1503	135
940	x	1050	130	102	96	78	M24 x 90	1000	1759331	3743	110	99	331750	179	160	42	37	1727770	3676	2240	1720	1523	138
960	x	1070	130	102	96	80	M24 x 90	1000	1840411	3834	110	99	322570	176	158	45	40	1811922	3775	2247	1739	1543	140
980	x	1090	130	102	96	81	M24 x 90	1000	1899788	3877	109	98	350070	179	161	40	36	1867256	3811	2337	1791	1584	143
1000	x	1110	130	102	96	82	M24 x 90	1000	1960015	3920	108	98	377570	182	164	35	32	1923305	3847	2430	1844	1626	146

More sizes on request
To continue see next page

Locking Assemblies Bending Loads RINGFEDER® RfN 7012

Explanations

d = Inner diameter	p_w = Surface pressure on shaft at given T_A	T_{res} at M_{bmax} = Remaining transmissible torque at indicated Mbmax and specified torque
D = Outer diameter	p_N = Surface pressure on hub at given T_A	F_{ax} at M_{bmax} = Transmissible axial force at max. bending moment
L = Overall length	M_{bmax} = Max. bending moment under the specified T_A	D_{N min} at Rp0,2 = Min. hub outer diameter depending of the given hub yield point Rp0,2 and part of bending moment
L₁ = Overall length (without screws)	p_{wmax} at M_{bmax} = Max. surface pressure on shaft at max. bending moment	G_w = Weight
L₃ = Width of ring	p_{Nmax} at M_{bmax} = Max. surface pressure on hub at max. bending moment	
n_{Sc} = Quantity of screws	p_{wmin} at M_{bmax} = Min. surface pressure on shaft at max. bending moment	
D_G = Thread	p_{Nmin} at M_{bmax} = Min. surface pressure on hub at max. bending moment	
T_{Ared} = Redused tightened torque of the screws under bending load		
T = Transmissible torque at given T_A		
F_{ax} = Transmissible axial force		

Ordering example

Locking Assembly	d	D
RfN 7012	160	210

Technical Information

- Surface finishes: Shaft and hub bores $R_a \leq 3,2 \mu\text{m}$
- Tolerances: Shaft: h9 · Hub: H9

Remark: The Values of the shaft- and hub pressures have been calculated with the screw tightening shown in the tables. Increase resp. reduction of the screw tightening torque results in different calculation values!

The specified pressures at M_{bmax} are sometimes very low. An operation near these limit values may therefore lead to increased fretting corrosion! More options with reduced bending moments (M_b 20% - M_b 80%) are also available.

Further information on RINGFEDER® RfN 7012 on www.ringfeder.com

Disclaimer of liability

All technical details and notes are non-binding and cannot be used as a basis for legal claims. The user is obligated to determine whether the represented products meet his requirements. We reserve the right carry out modifications at any time in the interests of technical progress.

Locking Assemblies Bending Loads

RINGFEDER® RfN 7012.2

Specially developed for use in belt drums

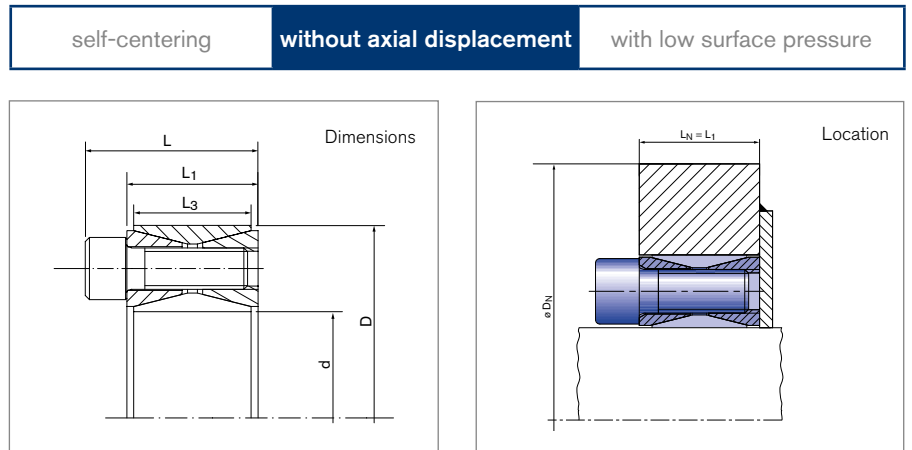

Locking Assembly dimensions				n _{Sc}	D _G	T _{Ared}	T	F _{ax}	P _W	p _N	M _{Bmax}	P _{Wmax} at M _{Bmax}	P _{Nmax} at M _{Bmax}	P _{Wmin} at M _{Bmax}	P _{Nmin} at M _{Bmax}	T _{res} at M _{Bmax}	F _{ax} at M _{Bmax}	D _{N min} at Rp _{0,2}			G _w	
d	x D	L	L ₁															L ₃	D _G	T		F _{ax}
mm	mm	mm	mm	mm	mm	Nm	Nm	N/mm ²	Nm	N/mm ²	N/mm ²	N/mm ²	N/mm ²	N/mm ²	Nm	kN	[N/mm ²]	mm	mm	mm	kg	
100	x 145	47	33	26	13	M12 x 30	125	10409	208	212	146	10300	406	280	19	13	1502	30	---	---	301	2,01
110	x 155	47	33	26	13	M12 x 30	125	11382	207	192	136	11200	383	272	1	0	2027	37	---	---	313	2,15
120	x 165	47	33	26	15	M12 x 30	125	14249	237	202	147	12880	404	294	0	0	6095	102	---	---	361	2,35
130	x 180	52	38	34	19	M12 x 35	125	19455	299	180	130	16400	359	259	0	0	10467	161	---	---	348	3,51
140	x 190	52	38	34	23	M12 x 35	125	25246	361	201	148	9700	299	221	103	76	23308	333	---	400	326	3,85
150	x 200	52	38	34	23	M12 x 35	125	26933	359	187	140	14690	326	244	48	36	22574	301	---	476	369	4,07
160	x 210	52	38	34	25	M12 x 35	125	31101	389	190	144	13380	308	235	71	54	28075	351	---	474	376	4,3
170	x 225	60	44	38	21	M14 x 40	190	36243	426	175	132	28080	350	265	0	0	22914	270	---	---	443	5,78
180	x 235	60	44	38	23	M14 x 40	190	41880	465	180	138	28860	350	268	11	8	30348	337	---	---	468	6,05
190	x 250	68	52	46	27	M14 x 45	190	51719	544	165	126	37000	312	237	19	14	36137	380	---	571	450	8,25
200	x 260	68	52	46	28	M14 x 45	190	56277	563	162	125	40180	314	241	11	8	39404	394	---	607	474	8,65
220	x 285	74	56	50	25	M16 x 50	295	74592	678	164	126	50440	313	241	14	11	54952	500	---	666	520	11,22
240	x 305	74	56	50	26	M16 x 50	295	84169	701	155	122	57100	310	244	0	0	61838	515	---	723	561	12,2
260	x 325	74	56	50	30	M16 x 50	295	104686	805	164	131	48910	287	229	42	33	92558	712	---	713	571	13,2
280	x 355	86,5	66	60	29	M18 x 60	405	131586	940	148	117	89170	297	234	0	0	96766	691	---	798	633	19,2
300	x 375	86,5	66	60	30	M18 x 60	405	145219	968	143	114	91850	285	228	0	0	112482	750	---	818	657	20,5
320	x 405	100,5	78	72	30	M20 x 70	580	201713	1261	145	115	139400	290	229	0	0	145793	911	---	889	712	29,6
340	x 425	100,5	78	72	31	M20 x 70	580	220626	1298	141	113	143500	281	225	0	0	167582	986	---	912	737	31,1
360	x 455	116	90	84	32	M22 x 80	780	293404	1630	143	113	178400	267	211	19	15	232936	1294	---	916	758	42,2
380	x 475	116	90	84	33	M22 x 80	780	318305	1675	139	111	204700	274	219	5	4	243754	1283	---	991	810	44
400	x 495	116	90	84	34	M22 x 80	780	344106	1721	136	110	217320	272	220	0	0	266798	1334	---	1035	845	46
420	x 515	116	90	84	37	M22 x 80	780	391995	1867	140	114	195820	257	210	24	19	339580	1617	---	1029	854	50
440	x 545	130	102	96	37	M24 x 90	1000	478752	2176	137	110	251950	248	200	26	21	407093	1850	---	1045	880	64,6
460	x 565	130	102	96	38	M24 x 90	1000	512615	2229	134	109	283500	254	206	14	12	427085	1857	---	1113	928	67,4
480	x 585	130	102	96	39	M24 x 90	1000	547520	2281	131	108	315100	259	212	4	3	447762	1866	---	1183	977	71
500	x 605	130	102	96	41	M24 x 90	1000	598054	2392	132	109	304200	250	207	14	12	514908	2060	---	1194	995	72,6

To continue see next page

Locking Assemblies Bending Loads RINGFEDER® RfN 7012.2

Locking Assembly dimensions				n _{Sc}	D _G	T _{Ared}	T	F _{ax}	p _w	p _N	M _{bmax}	p _{wmax} at M _{bmax}	p _{Nmax} at M _{bmax}	p _{wmin} at M _{bmax}	p _{Nmin} at M _{bmax}	T _{res} at M _{bmax}	F _{ax t} at M _{bmax}	D _{N min} at Rp _{0,2}			G _w	
d	x D	L	L ₁															L ₃	Nm	Nm		N/mm ²
mm	mm	mm	mm	mm	mm	Nm	Nm	N/mm ²	Nm	N/mm ²				Nm	kN	mm	mm	mm	mm	kg		
520	x 630	130	102	96	42	M24 x 90	1000	635586	2445	130	107	345050	259	214	1	1	533770	2053	---	1281	1056	80
540	x 650	130	102	96	43	M24 x 90	1000	674155	2497	128	106	355400	256	212	0	0	572866	2122	---	1314	1086	82
560	x 670	130	102	96	45	M24 x 90	1000	729980	2607	129	108	365700	255	213	2	2	631770	2256	---	1362	1123	85
580	x 690	130	102	96	47	M24 x 90	1000	787923	2717	129	109	354800	248	209	11	9	703519	2426	---	1372	1141	88
600	x 710	130	102	96	48	M24 x 90	1000	830673	2769	128	108	386400	253	213	3	2	735331	2451	---	1443	1190	91
620	x 730	130	102	96	49	M24 x 90	1000	874450	2821	126	107	401500	251	214	0	0	776828	2506	---	1484	1224	93
640	x 750	130	102	96	52	M24 x 90	1000	956024	2988	129	110	364600	240	204	18	16	883770	2762	---	1465	1225	96
660	x 770	130	102	96	54	M24 x 90	1000	1021852	3097	130	111	353700	234	200	26	22	958686	2905	---	1477	1244	99
680	x 790	130	102	96	54	M24 x 90	1000	1050855	3091	126	108	357760	228	196	23	20	988081	2906	---	1489	1261	102
700	x 810	130	102	96	54	M24 x 90	1000	1079804	3085	122	105	357770	221	191	23	20	1018812	2911	---	1495	1275	104
720	x 830	130	102	96	54	M24 x 90	1000	1108702	3080	118	103	354670	214	185	23	20	1050443	2918	---	1498	1287	107
740	x 850	130	102	96	56	M24 x 90	1000	1179681	3188	119	104	367670	215	188	23	20	1120922	3030	---	1548	1326	110
760	x 870	130	102	96	58	M24 x 90	1000	1252745	3297	120	105	379250	217	189	23	20	1193960	3142	---	1595	1363	113
780	x 890	130	102	96	59	M24 x 90	1000	1305758	3348	119	104	385650	215	188	23	20	1247509	3199	---	1623	1390	116
800	x 910	130	102	96	60	M24 x 90	1000	1359784	3399	117	103	392150	213	187	22	20	1302011	3255	---	1652	1417	118

More sizes on request

Explanations

d = Inner diameter	p_w = Surface pressure on shaft at given T _A	T_{res} at M_{bmax} = Remaining transmissible torque at indicated Mbmax and specified torque
D = Outer diameter	p_N = Surface pressure on hub at given T _A	F_{ax} at M_{bmax} = Transmissible axial force at max. bending moment
L = Overall length	M_{bmax} = Max. bending moment under the specified T _A	D_{N min} at Rp_{0,2} = Min. hub outer diameter depending of the given hub yield point Rp _{0,2} and part of bending moment
L₁ = Overall length (without screws)	p_{wmax} at M_{bmax} = Max. surface pressure on shaft at max. bending moment	G_w = Weight
L₃ = Width of ring	p_{Nmax} at M_{bmax} = Max. surface pressure on hub at max. bending moment	
n_{Sc} = Quantity of screws	p_{wmin} at M_{bmax} = Min. surface pressure on shaft at max. bending moment	
D_G = Thread	p_{Nmin} at M_{bmax} = Min. surface pressure on hub at max. bending moment	
T_{Ared} = Redused tightened torque of the screws under bending load		
T = Transmissible torque at given T _A		
F_{ax} = Transmissible axial force		

Ordering example

Locking Assembly	d	D
RfN 7012.2	200	260

Technical Information

- Surface finishes: Shaft and hub bores R_a ≤ 3,2 μm
- Tolerances: Shaft: h9 · Hub: H9

Remark: The Values of the shaft- and hub pressures have been calculated with the screw tightening shown in the tables. Increase resp. reduction of the screw tightening torque results in different calculation values!

The specified pressures at M_{bmax} are sometimes very low. An operation near these limit values may therefore lead to increased fretting corrosion! More options with reduced bending moments (M_b 20% - M_b 80%) are also available.

Further information on RINGFEDER® RfN 7012.2 on www.ringfeder.com

Disclaimer of liability

All technical details and notes are non-binding and cannot be used as a basis for legal claims. The user is obligated to determine whether the represented products meet his requirements. We reserve the right carry out modifications at any time in the interests of technical progress.

Locking Assemblies Bending Loads

RINGFEDER® RfN 7015.0

Transfer of bending moments possible, highest torque and/or axial forces, excellent concentricity



self-centering without axial displacement with low surface pressure

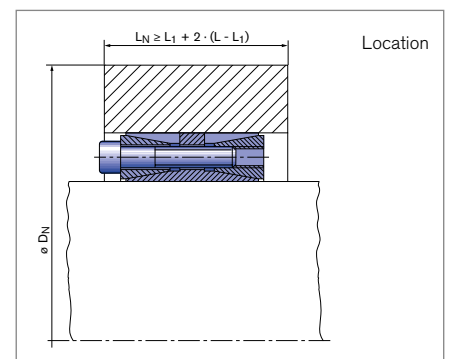
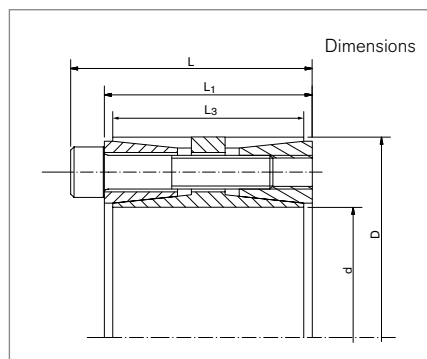

Locking Assembly dimensions				Locking screws													D _{N min} at R _{p0,2}			G _w			
d	x	D	L	L ₁	L ₃	n _{Sc}	D _G	T _{Ared}	T	F _{ax}	P _w	P _N	M _{Bmax}	P _{wmax} at M _{Bmax}	P _{Nmax} at M _{Bmax}	P _{wmin} at M _{Bmax}	P _{Nmin} at M _{Bmax}	T _{res} at M _{Bmax}	F _{ax} at M _{Bmax}		250	350	450
mm		mm	mm	mm	mm			Nm	Nm	N/mm ²	N/mm ²	N/mm ²	N/mm ²	N/mm ²				Nm	kN	[N/mm ²]			kg
100	x	145	77	65	60	10	M12 x 55	115	11297	226	157	108	11200	215	148	98	68	1474	29	258	215	198	4,1
110	x	155	77	65	60	10	M12 x 55	115	12426	226	142	101	12300	201	143	84	60	1767	32	266	225	209	4,4
120	x	165	77	65	60	12	M12 x 55	115	16267	271	157	114	16100	227	165	87	63	2326	39	333	261	236	4,8
130	x	180	86	74	68	15	M12 x 60	115	22028	339	156	113	21900	224	162	89	64	2375	37	361	283	257	6,5
140	x	190	86	74	68	18	M12 x 60	115	28468	407	174	128	21600	236	174	113	83	18543	265	430	315	281	7
150	x	200	86	74	68	18	M12 x 60	115	30501	407	163	122	30300	224	183	82	61	3495	47	---	346	305	7,4
160	x	210	86	74	68	21	M12 x 60	115	37957	474	178	136	22500	234	179	122	93	30569	382	501	356	315	7,8
170	x	225	95	81	75	18	M14 x 65	185	47955	564	179	135	33300	244	184	114	86	34508	406	---	391	344	10
180	x	235	95	81	75	18	M14 x 65	185	50776	564	169	129	49800	260	199	77	59	9909	110	---	445	379	10,6
190	x	250	108	94	88	20	M14 x 75	185	59552	627	149	113	58300	224	170	74	57	12149	128	574	417	372	14,3
200	x	260	108	94	88	24	M14 x 75	185	75224	752	170	131	30900	208	160	132	102	68585	686	535	414	374	15
220	x	285	120	104	98	18	M16 x 90	285	84791	771	152	117	84300	230	178	74	57	9107	83	---	495	435	19,8
240	x	305	120	104	98	24	M16 x 90	285	123332	1028	186	146	52500	230	181	141	111	111599	930	---	540	471	21,4
260	x	325	120	104	98	25	M16 x 90	285	139176	1071	178	143	51900	219	175	138	110	129137	993	801	558	492	23
280	x	355	144	126	120	24	M18 x 110	390	174092	1244	161	127	124600	223	176	99	78	121585	868	---	624	545	35,2
300	x	375	144	126	120	25	M18 x 110	390	194299	1295	157	125	139200	222	177	92	73	135556	904	---	663	578	37,4
320	x	405	162	142	135	25	M20 x 120	550	265703	1661	159	125	171300	216	171	101	80	203112	1269	986	692	611	51,3
340	x	425	162	142	135	25	M20 x 120	550	282310	1661	149	120	229800	222	178	77	61	163984	965	---	753	656	54,1
360	x	455	187	165	158	25	M22 x 130	745	371148	2062	149	118	295300	214	169	84	66	224830	1249	1118	780	688	75,4
380	x	475	187	165	158	25	M22 x 130	745	391767	2062	141	113	389800	223	178	60	48	39211	206	---	854	741	79
400	x	495	187	165	158	25	M22 x 130	745	412387	2062	134	108	410300	215	174	53	43	41431	207	---	870	761	82,8
420	x	515	187	165	158	30	M22 x 130	745	519607	2474	153	125	311300	212	173	94	77	416033	1981	---	900	788	86,5
440	x	545	204	180	172	30	M24 x 150	960	639702	2908	154	124	417000	216	175	91	74	485108	2205	---	960	839	110
460	x	565	204	180	172	30	M24 x 150	960	668779	2908	147	120	485800	217	177	77	63	459635	1998	---	1006	875	114
480	x	585	204	180	172	32	M24 x 150	960	744381	3102	150	123	446100	212	174	89	73	595900	2483	---	1025	897	119
500	x	605	204	180	172	32	M24 x 150	960	775396	3102	144	119	474800	207	171	82	68	613029	2452	---	1045	919	123

To continue see next page

Locking Assemblies Bending Loads RINGFEDER® RfN 7015.0

Locking Assembly dimensions					Locking screws													DN min at Rp0,2					
d	x	D	L	L ₁	L ₃	n _{Sc}	D _G	T _{Ared}	T	F _{ax}	p _w	p _N	M _{bmax}	p _{wmax} at M _{bmax}	p _{Nmax} at M _{bmax}	p _{wmin} at M _{bmax}	p _{Nmin} at M _{bmax}	T _{res} at M _{bmax}	F _{ax} at M _{bmax}	250 350 450			G _w
mm					mm			Nm	Nm	N/mm ²	Nm	N/mm ²						Nm	kN	mm			kg
520	x	630	227	200	190	30	M27 x 160	1440	1014357	3901	156	129	613500	219	181	93	77	807798	3107	---	1140	986	148
540	x	650	227	200	190	30	M27 x 160	1440	1053370	3901	150	125	674900	217	180	84	69	808764	2995	---	1172	1015	154
560	x	670	227	200	190	30	M27 x 160	1440	1092384	3901	145	121	684200	210	176	80	67	851571	3041	---	1177	1029	160
580	x	690	227	200	190	30	M27 x 160	1440	1131398	3901	140	118	890500	222	186	58	49	697904	2407	---	1292	1103	165
600	x	710	227	200	190	32	M27 x 160	1440	1248439	4161	144	122	798300	215	182	73	62	959853	3200	---	1293	1116	170
620	x	730	227	200	190	32	M27 x 160	1440	1290054	4161	140	119	1004600	226	192	53	45	809331	2611	---	1417	1193	177
640	x	750	227	200	190	35	M27 x 160	1440	1456512	4552	148	126	651400	202	173	94	80	1302730	4071	---	1296	1139	182
660	x	770	227	200	190	35	M27 x 160	1440	1502028	4552	143	123	772500	206	176	81	69	1288151	3903	---	1359	1186	187
680	x	790	227	200	190	36	M27 x 160	1440	1591760	4682	143	123	435600	177	153	109	94	1530997	4503	1579	1239	1124	193
700	x	810	227	200	190	36	M27 x 160	1440	1638576	4682	139	120	641900	188	163	90	78	1507613	4307	1789	1329	1189	198
720	x	830	227	200	190	40	M27 x 160	1440	1872658	5205	150	130	645200	198	172	103	89	1758001	4883	2065	1428	1258	204
740	x	850	227	200	190	40	M27 x 160	1440	1924677	5205	146	127	654500	193	168	99	86	1809975	4892	2016	1436	1273	209
760	x	870	227	200	190	40	M27 x 160	1440	1976695	5205	142	124	663800	189	165	96	84	1861906	4900	1980	1446	1288	215
780	x	890	227	200	190	40	M27 x 160	1440	2028713	5205	139	122	673100	185	162	93	81	1913796	4907	1953	1457	1304	220
800	x	910	227	200	190	42	M27 x 160	1440	2184768	5462	142	125	777900	194	170	90	79	2041588	5104	2220	1554	1372	225

More sizes on request

Explanations

d = Inner diameter	p_w = Surface pressure on shaft at given T _A	T_{res} at M_{bmax} = Remaining transmissible torque at indicated Mbmax and specified torque
D = Outer diameter	p_N = Surface pressure on hub at given T _A	F_{ax} at M_{bmax} = Transmissible axial force at max. bending moment
L = Overall length	M_{bmax} = Max. bending moment under the specified T _A	DN min at Rp0,2 = Min. hub outer diameter depending of the given hub yield point Rp0,2 and part of bending moment
L₁ = Overall length (without screws)	p_{wmax} at M_{bmax} = Max. surface pressure on shaft at max. bending moment	G_w = Weight
L₃ = Width of ring	p_{Nmax} at M_{bmax} = Max. surface pressure on hub at max. bending moment	
n_{Sc} = Quantity of screws	p_{wmin} at M_{bmax} = Min. surface pressure on shaft at max. bending moment	
D_G = Thread	p_{Nmin} at M_{bmax} = Min. surface pressure on hub at max. bending moment	
T_{Ared} = Redused tightened torque of the screws under bending load		
T = Transmissible torque at given T _A		
F_{ax} = Transmissible axial force		

Ordering example

Locking Assembly	d	D
RfN 7015.0	240	305

Technical Information

- Surface finishes: Shaft and hub bores R_a ≤ 3,2 μm
- Tolerances: Shaft: h8 · Hub: H8

Remark: The Values of the shaft- and hub pressures have been calculated with the screw tightening shown in the tables. Increase resp. reduction of the screw tightening torque results in different calculation values!

The specified pressures at M_{bmax} are sometimes very low. An operation near these limit values may therefore lead to increased fretting corrosion! More options with reduced bending moments (M_b 20% - M_b 80%) are also available.

Further information on RINGFEDER® RfN 7015.0 on www.ringfeder.com

Disclaimer of liability

All technical details and notes are non-binding and cannot be used as a basis for legal claims. The user is obligated to determine whether the represented products meet his requirements. We reserve the right carry out modifications at any time in the interests of technical progress.

Locking Assemblies Bending Loads

RINGFEDER® RfN 7015.1

Reduced surface pressures



self-centering | without axial displacement | with low surface pressure

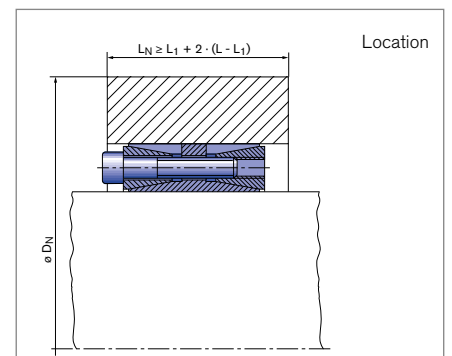
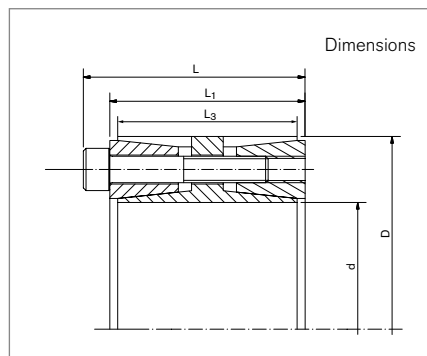

Locking Assembly dimensions			Locking screws															D _{N min} at Rp _{0,2}			Gw		
d	x D	L	L ₁	L ₃	n _{Sc}	D _G	T _A	T	F _{ax}	PW	p _N	M _{bmax}	PW _{max} at M _{bmax}	pN _{max} at M _{bmax}	PW _{min} at M _{bmax}	pN _{min} at M _{bmax}	T _{res} at M _{bmax}	F _{ax} at M _{bmax}	250	350		450	
mm		mm					Nm	Nm	Nm	N/mm ²		Nm	N/mm ²				Nm	kN	[N/mm ²]			kg	
100	x	145	75	65	60	9	M10 x 55	83	6575	132	91	63	6540	125	86	57	39	681	14	192	179	172	4,1
110	x	155	75	65	60	10	M10 x 55	83	8037	146	92	65	7900	130	92	55	39	1475	27	210	194	186	4,4
120	x	165	75	65	60	12	M10 x 55	83	10521	175	101	74	10460	147	107	56	41	1128	19	238	215	205	4,8
130	x	180	84	74	68	15	M10 x 60	83	14247	219	101	73	14170	145	105	58	42	1476	23	258	234	223	6,5
140	x	190	84	74	68	15	M10 x 60	83	15343	219	94	69	15260	138	101	50	37	1589	23	269	245	234	7
150	x	200	84	74	68	16	M10 x 60	83	17534	234	94	70	17440	140	105	47	35	1816	24	288	261	248	7,4
160	x	210	84	74	68	18	M10 x 60	83	21041	263	99	75	20930	151	115	46	35	2160	27	317	282	267	7,8
170	x	225	93	81	75	15	M12 x 65	145	27352	322	105	80	27210	159	120	52	39	2788	33	348	307	289	10
180	x	235	93	81	75	16	M12 x 65	145	30892	343	106	81	30730	164	125	49	37	3161	35	374	326	306	10,6
190	x	250	106	94	88	18	M12 x 75	145	36684	386	96	73	36500	144	109	48	37	3674	39	371	333	315	14,3
200	x	260	106	94	88	20	M12 x 75	145	42906	429	101	78	42690	154	119	48	37	4298	43	406	357	336	15
220	x	285	116	104	98	21	M12 x 80	145	49556	451	89	69	49300	135	104	43	33	5033	46	416	375	356	19,8
240	x	305	116	104	98	24	M12 x 80	145	61784	515	93	73	61470	145	114	41	32	6225	52	470	415	391	21,4
260	x	325	116	104	98	27	M12 x 80	145	75300	579	97	77	74920	155	124	38	30	7552	58	531	458	428	23
280	x	355	140	126	120	28	M14 x 100	230	115034	822	106	84	114450	164	129	49	39	11574	83	605	513	476	35,2
300	x	375	140	126	120	28	M14 x 100	230	123250	822	99	80	122630	157	125	42	34	12351	82	623	534	498	37,4
320	x	405	158	142	135	28	M16 x 110	355	179962	1125	110	87	179050	171	135	49	39	18093	113	716	597	551	51,3
340	x	425	158	142	135	28	M16 x 110	355	191209	1125	103	83	190250	164	131	42	34	19131	113	733	618	573	54,1
360	x	455	183	165	158	24	M18 x 140	485	209622	1165	84	67	208570	130	103	38	30	20978	117	668	600	570	75,4
380	x	475	183	165	158	27	M18 x 140	485	248927	1310	90	72	247670	141	113	38	30	24980	131	736	648	611	79
400	x	495	183	165	158	32	M18 x 140	485	310552	1553	101	82	308990	162	131	40	32	31104	156	861	723	669	82,8
420	x	515	183	165	158	32	M18 x 140	485	326079	1553	96	78	324440	157	128	35	28	32655	155	879	744	691	86,5
440	x	545	200	180	172	27	M20 x 140	690	372775	1694	91	74	370900	147	119	35	28	37338	170	871	758	711	110
460	x	565	200	180	172	27	M20 x 140	690	389719	1694	87	71	387760	143	117	31	25	39026	170	891	779	732	114
480	x	585	200	180	172	30	M20 x 140	690	451848	1883	93	76	449500	155	127	30	25	46004	192	986	839	781	119
500	x	605	200	180	172	30	M20 x 140	690	470675	1883	89	74	468300	151	125	27	22	47224	189	1006	861	802	123

To continue see next page

Locking Assemblies Bending Loads RINGFEDER® RfN 7015.1

Locking Assembly dimensions			Locking screws															D _{N min} at Rp _{0,2}					
d	x	D	L	L ₁	L ₃	n _{Sc}	D _G	T _A	T	F _{ax}	P _W	P _N	M _{bmax}	P _{Wmax} at M _{bmax}	P _{Nmax} at M _{bmax}	P _{Wmin} at M _{bmax}	P _{Nmin} at M _{bmax}	T _{res} at M _{bmax}	F _{ax} at M _{bmax}	250 350 450			G _w
mm			mm					Nm	Nm		N/mm ²		Nm	N/mm ²				Nm	kN	mm			kg
520	x	630	220	200	190	32	M20 x 150	690	522135	2008	80	66	519500	134	110	27	22	52395	202	961	851	804	148
540	x	650	220	200	190	32	M20 x 150	690	542218	2008	77	64	539400	131	109	24	20	55205	204	982	873	826	154
560	x	670	220	200	190	36	M20 x 150	690	632587	2259	84	70	629400	144	120	24	20	63421	227	1084	938	878	160
580	x	690	220	200	190	36	M20 x 150	690	655180	2259	81	68	651890	141	119	21	18	65573	226	1104	960	900	165
600	x	710	220	200	190	36	M20 x 150	690	677772	2259	78	66	674370	138	117	18	16	67823	226	1125	982	922	170
620	x	730	220	200	190	36	M20 x 150	690	700364	2259	76	64	696850	136	115	16	13	70074	226	1146	1004	944	175
640	x	750	220	200	190	36	M20 x 150	690	722957	2259	73	63	705037	132	113	15	13	159967	500	1160	1022	963	180
660	x	770	220	200	190	40	M20 x 150	690	828388	2510	79	68	783300	142	122	16	14	269570	817	1260	1085	1014	194
680	x	790	220	200	190	40	M20 x 150	690	853491	2510	77	66	783300	138	119	15	13	338951	997	1268	1101	1032	199
700	x	810	220	200	190	40	M20 x 150	690	878593	2510	75	64	783300	134	116	15	13	397954	1137	1277	1117	1049	205
720	x	830	220	200	190	40	M20 x 150	690	903696	2510	73	63	783300	131	113	15	13	450675	1252	1287	1133	1067	210
740	x	850	220	200	190	42	M20 x 150	690	975239	2636	74	65	822500	133	116	15	13	524008	1416	1341	1172	1101	216
760	x	870	220	200	190	42	M20 x 150	690	1001596	2636	72	63	822500	130	113	14	13	571567	1504	1351	1188	1119	221
780	x	890	220	200	190	42	M20 x 150	690	1027954	2636	70	62	822500	127	111	14	12	616590	1581	1362	1205	1137	227
800	x	910	220	200	190	42	M20 x 150	690	1054312	2636	69	60	822500	123	108	14	12	659597	1649	1374	1222	1155	232

More sizes on request

Explanations

d = Inner diameter	P_W = Surface pressure on shaft at given T _A	T_{res} at M_{bmax} = Remaining transmissible torque at indicated Mbmax and specified torque
D = Outer diameter	P_N = Surface pressure on hub at given T _A	F_{ax} at M_{bmax} = Transmissible axial force at max. bending moment
L = Overall length	M_{bmax} = Max. bending moment under the specified T _A	D_{N min} at Rp_{0,2} = Min. hub outer diameter depending of the given hub yield point Rp _{0,2} and part of bending moment
L₁ = Overall length (without screws)	P_{Wmax} at M_{bmax} = Max. surface pressure on shaft at max. bending moment	G_w = Weight
L₃ = Width of ring	P_{Nmax} at M_{bmax} = Max. surface pressure on hub at max. bending moment	
n_{Sc} = Quantity of screws	P_{Wmin} at M_{bmax} = Min. surface pressure on shaft at max. bending moment	
D_G = Thread	P_{Nmin} at M_{bmax} = Min. surface pressure on hub at max. bending moment	
T_A = Max tightened torque of the clamping screws		
T = Transmissible torque at given T _A		
F_{ax} = Transmissible axial force		

Ordering example

Locking Assembly	d	D
RfN 7015.1	620	730

Technical Information

- Surface finishes: Shaft and hub bores R_a ≤ 3,2 μm
- Tolerances: Shaft: h8 · Hub: H8

Remark: The Values of the shaft- and hub pressures have been calculated with the screw tightening shown in the tables. Increase resp. reduction of the screw tightening torque results in different calculation values!

The specified pressures at M_{bmax} are sometimes very low. An operation near these limit values may therefore lead to increased fretting corrosion! More options with reduced bending moments (M_b 20% - M_b 80%) are also available.

Disclaimer of liability

All technical details and notes are non-binding and cannot be used as a basis for legal claims. The user is obligated to determine whether the represented products meet his requirements. We reserve the right carry out modifications at any time in the interests of technical progress.

Locking Assemblies Bending Loads

RINGFEDER® RfN 7515

Three part Locking Assembly

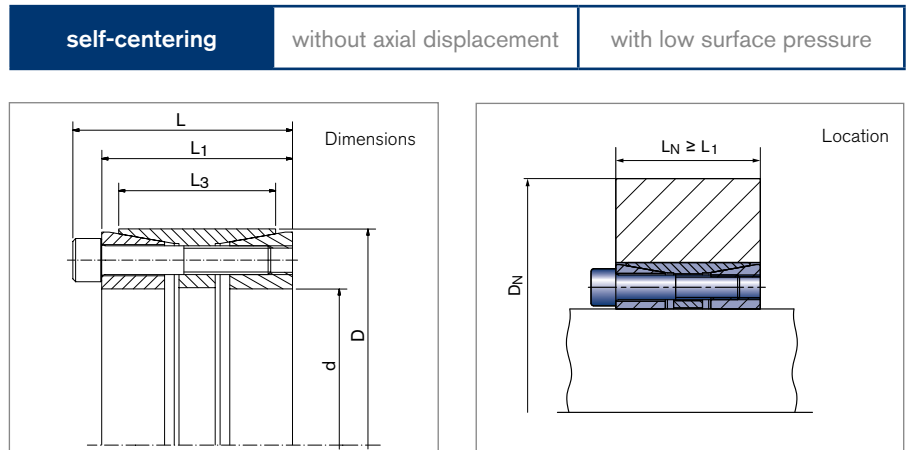

Locking Assembly dimensions				Locking screws														DN min at Rp0,2			Gw		
d	x	D	L	L ₁	L ₃	n _{Sc}	D _G	T _A	T	F _{ax}	P _w	P _N	M _{bmax}	P _{wmax} at M _{bmax}	P _{Nmax} at M _{bmax}	P _{wmin} at M _{bmax}	P _{Nmin} at M _{bmax}	T _{res} at M _{bmax}	F _{ax} at M _{bmax}	250		350	450
mm				mm					Nm	Nm	N/mm ²	Nm	N/mm ²				Nm	kN	[N/mm ²]			kg	
60	x	95	58	50	42	8	M8 x 40	41	4299	143	186	118	2800	228	144	145	91	3262	109	184	148	133	1,48
70	x	110	70	60	50	8	M10 x 50	83	7280	208	197	125	5040	242	154	152	97	5253	150	227	177	158	2,7
80	x	120	70	60	50	10	M10 x 50	83	10399	260	216	144	7210	272	181	159	106	7494	187	---	214	185	2,7
90	x	130	70	60	50	11	M10 x 50	83	12869	286	211	146	8890	272	189	149	103	9305	207	---	239	204	2,9
100	x	145	82	70	60	10	M12 x 60	145	18881	378	209	144	10080	254	175	163	112	15865	319	347	253	220	4,3
110	x	155	82	70	60	10	M12 x 60	145	20769	378	190	135	11070	235	167	144	102	17573	320	348	262	230	4,5
120	x	165	82	70	60	11	M12 x 60	145	24923	415	191	139	14490	246	179	137	99	20278	338	406	291	252	5
130	x	180	91	79	65	14	M12 x 70	145	34364	529	207	150	19710	262	190	152	110	28150	433	---	331	283	6,6
140	x	190	91	79	65	15	M12 x 70	145	39651	566	206	152	19440	257	189	156	115	34558	494	---	349	298	7
150	x	200	91	79	65	15	M12 x 70	145	42483	566	193	144	27270	259	194	127	95	32575	434	---	374	318	7,5
160	x	210	91	79	65	16	M12 x 70	145	48336	604	193	147	22050	243	185	143	109	43014	538	---	379	326	7,9
170	x	225	106	92	78	15	M14 x 80	230	65790	774	195	147	30900	243	183	147	111	58082	683	---	404	348	10,9
180	x	235	106	92	78	15	M14 x 80	230	69660	774	184	141	44820	250	191	118	90	53327	593	---	435	371	11,4
190	x	250	116	102	88	16	M14 x 80	230	78432	826	165	125	54460	226	172	104	79	56442	594	581	428	375	14,6
200	x	260	116	102	88	18	M14 x 80	230	92880	929	176	135	40470	219	169	133	102	83600	836	590	441	386	14,8
220	x	285	126	110	96	15	M16 x 90	355	116459	1059	173	133	75870	236	182	109	84	88353	803	---	509	439	19,9
240	x	305	124	108	96	20	M16 x 90	355	169394	1412	211	166	43460	245	193	176	139	163724	1364	---	568	483	21,5
260	x	325	127	111	96	20	M16 x 90	355	183510	1412	176	141	67410	221	177	130	104	170681	1313	785	567	493	22,9
280	x	355	131	111	96	15	M20 x 90	690	230199	1644	205	162	112140	277	219	133	105	201038	1436	---	739	604	33,1
300	x	375	131	111	96	16	M20 x 90	690	263085	1754	204	163	125280	279	223	129	103	231341	1542	---	799	648	30,6
320	x	405	156	136	124	20	M20 x 110	690	350780	2192	189	150	170050	252	199	126	100	306805	1918	---	759	644	46,3
340	x	425	156	136	124	20	M20 x 110	690	372704	2192	178	143	206820	250	200	106	85	310054	1824	---	815	687	48,9
360	x	455	175	155	140	20	M22 x 130	930	487557	2709	174	137	265770	239	189	108	85	408752	2271	---	835	714	66,2
380	x	475	175	155	140	20	M22 x 130	930	514644	2709	164	132	350820	247	197	82	66	376541	1982	---	901	761	69,5
400	x	495	175	155	140	22	M22 x 130	930	595903	2980	172	139	369270	254	205	89	72	467697	2338	---	971	811	73,4
420	x	515	175	155	140	24	M22 x 130	930	682580	3250	179	146	286396	239	195	118	96	619591	2950	---	967	820	76,5

To continue see next page

Locking Assemblies Bending Loads RINGFEDER® RfN 7515

Locking Assembly dimensions				Locking screws			T	F _{ax}	p _w	p _N	M _{bmax}	p _{wmax} at M _{bmax}	p _{Nmax} at M _{bmax}	p _{wmin} at M _{bmax}	p _{Nmin} at M _{bmax}	T _{res} at M _{bmax}	F _{ax} at M _{bmax}	D _{N min} at R _{p0,2}			G _w		
d	x	D	L	L ₁	L ₃	n _{Sc}												D _G	T _A	250		350	450
mm				mm			Nm	Nm	N/mm ²		Nm	N/mm ²				Nm	kN						
440	x	535	175	155	140	24	M22 x 130	930	715084	3250	170	140	387810	249	205	92	75	600790	2731	---	1047	875	80
460	x	555	175	155	140	24	M22 x 130	930	747588	3250	163	135	463939	253	210	73	61	586215	2549	---	1109	920	83
480	x	575	175	155	140	25	M22 x 130	930	812595	3386	163	136	437178	244	204	81	68	684972	2854	---	1119	938	86
500	x	595	175	155	140	25	M22 x 130	930	846453	3386	156	131	436816	234	197	78	66	725034	2900	---	1125	952	90
520	x	615	175	155	140	28	M22 x 130	930	985949	3792	168	142	506360	255	216	81	69	845987	3254	---	1263	1038	93
540	x	635	175	155	140	28	M22 x 130	930	1023870	3792	162	138	629600	266	226	58	49	807412	2990	---	1371	1105	96
560	x	655	175	155	140	30	M22 x 130	930	1137633	4063	167	143	541600	254	217	81	69	1000439	3573	---	1352	1109	101
580	x	675	175	155	140	30	M22 x 130	930	1178263	4063	162	139	664900	264	227	59	51	972734	3354	---	1461	1176	104
600	x	695	175	155	140	30	M22 x 130	930	1218893	4063	156	135	782334	272	235	40	34	934694	3116	---	1570	1242	108
620	x	715	175	155	140	30	M22 x 130	930	1259522	4063	151	131	909163	282	244	20	18	871676	2812	---	1698	1315	112
640	x	735	175	155	140	30	M22 x 130	930	1300152	4063	146	128	631858	234	204	58	51	1136288	3551	---	1434	1200	116

More sizes on request

Explanations

d = Inner diameter	p_w = Surface pressure on shaft at given T _A	T_{res} at M_{bmax} = Remaining transmissible torque at indicated Mbmax and specified torque
D = Outer diameter	p_N = Surface pressure on hub at given T _A	F_{ax} at M_{bmax} = Transmissible axial force at max. bending moment
L = Overall length	M_{bmax} = Max. bending moment under the specified T _A	D_{N min} at R_{p0,2} = Min. hub outer diameter depending of the given hub yield point R _{p0,2} and part of bending moment
L₁ = Overall length (without screws)	p_{wmax} at M_{bmax} = Max. surface pressure on shaft at max. bending moment	G_w = Weight
L₃ = Width of ring	p_{Nmax} at M_{bmax} = Max. surface pressure on hub at max. bending moment	
n_{Sc} = Quantity of screws	p_{wmin} at M_{bmax} = Min. surface pressure on shaft at max. bending moment	
D_G = Thread	p_{Nmin} at M_{bmax} = Min. surface pressure on hub at max. bending moment	
T_A = Max tightened torque of the clamping screws		
T = Transmissible torque at given T _A		
F_{ax} = Transmissible axial force		

Ordering example

Locking Assembly	d	D
RfN 7515	300	375

Technical Information

- Surface finishes: Shaft bore R_a ≤ 1,6 μm · Hub bore R_a ≤ 3,2 μm
- Tolerances: Shaft: h8 · Hub: H8

Remark: The Values of the shaft- and hub pressures have been calculated with the screw tightening shown in the tables. Increase resp. reduction of the screw tightening torque results in different calculation values!

The specified pressures at M_{bmax} are sometimes very low. An operation near these limit values may therefore lead to increased fretting corrosion! More options with reduced bending moments (M_b 20% - M_b 80%) are also available.

Further information on RINGFEDER® RfN 7515 on www.ringfeder.com

Disclaimer of liability

All technical details and notes are non-binding and cannot be used as a basis for legal claims. The user is obligated to determine whether the represented products meet his requirements. We reserve the right carry out modifications at any time in the interests of technical progress.



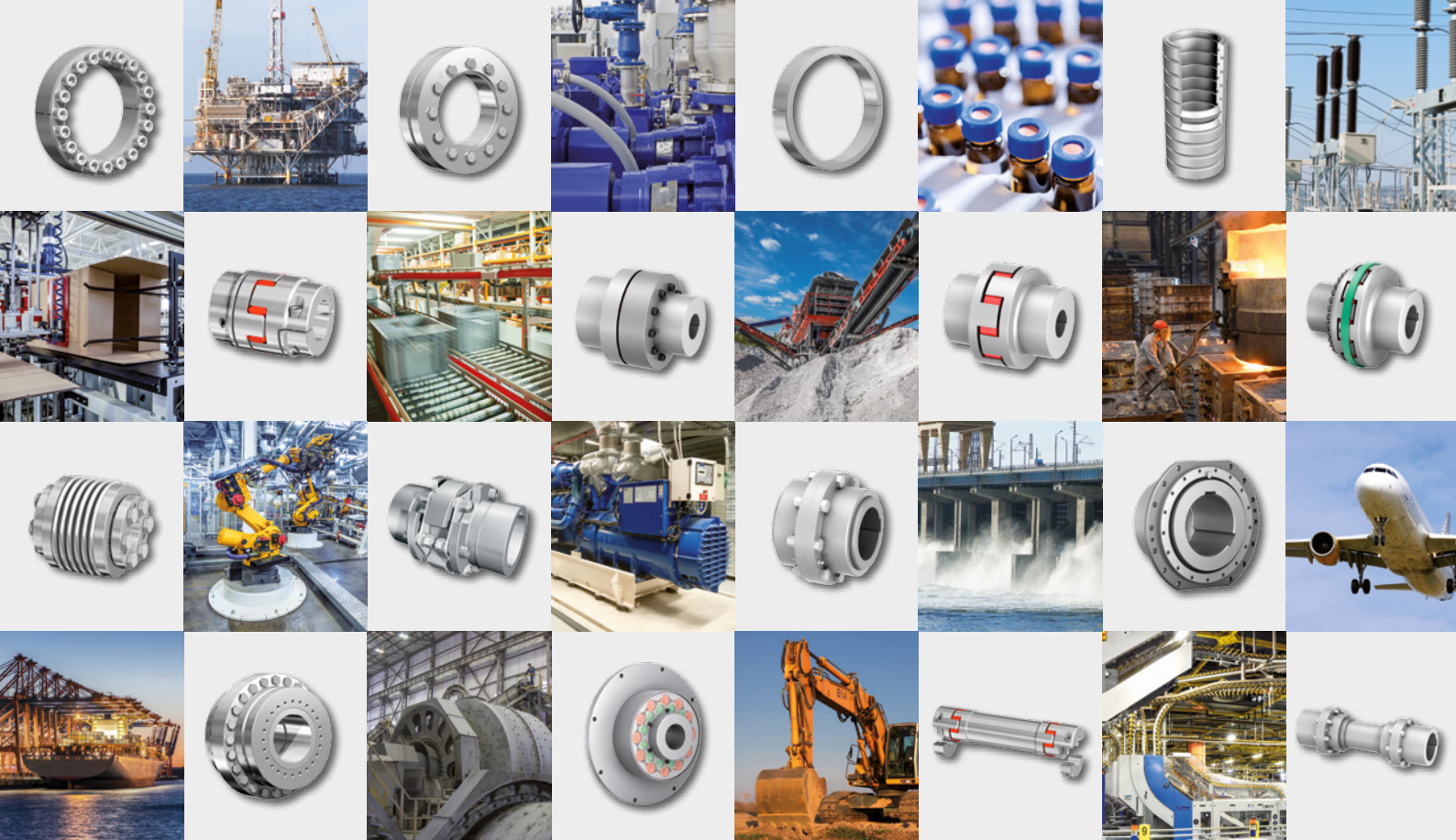

RINGFEDER POWER TRANSMISSION GMBH

Werner-Heisenberg-Straße 18, D-64823 Groß-Umstadt, Germany · Phone: +49 (0) 6078 9385-0 · Fax: +49 (0) 6078 9385-100
 E-mail: sales.international@ringfeder.com

RINGFEDER POWER TRANSMISSION TSCHAN GMBH

Zweibrücker Straße 104, D-66538 Neunkirchen, Germany · Phone: +49 (0) 6821 866-0 · Fax: +49 (0) 6821 866-4111
 E-mail: sales.tschan@ringfeder.com

RINGFEDER POWER TRANSMISSION USA CORPORATION

165 Carver Avenue, Westwood, NJ 07675, USA · Toll Free: +1 888 746-4333 · Phone: +1 201 666 3320 · Fax: +1 201 664 6053
 E-mail: sales.usa@ringfeder.com

HENFEL INDÚSTRIA METALÚRGICA LTDA.

Av. Major Hilário Tavares Pinheiro, 3447 · CEP 14871 300 · Jaboticabal - SP - Brazil · Phone: +55 (16) 3209-3422
 E-mail: vendas@henfel.com.br

RINGFEDER POWER TRANSMISSION INDIA PRIVATE LIMITED

Plot No. 4, Door No. 220, Mount - Poonamallee Road, Kattupakkam, Chennai – 600 056, India
 Phone: +91 (0) 44-2679 1411 · Fax: +91 (0) 44-2679 1422 · E-mail: sales.india@ringfeder.com

KUNSHAN RINGFEDER POWER TRANSMISSION COMPANY LIMITED

NO. 406 Jiande Road, Zhangpu 215321, Kunshan, Jiangsu Province, China
 Phone: +86 (0) 512-5745-3960 · Fax: +86 (0) 512-5745-3961 · E-mail: sales.china@ringfeder.com

Partner for Performance
www.ringfeder.com

